



(51) International Patent Classification:

B65D 77/06 (2006.01) *B65D 5/74* (2006.01)
B65D 25/42 (2006.01)

(21) International Application Number:

PCT/US2023/010017

(22) International Filing Date:

03 January 2023 (03.01.2023)

(25) Filing Language:

English

(26) Publication Language:

English

(30) Priority Data:

63/266,372 04 January 2022 (04.01.2022) US

(71) Applicant: **THE COCA-COLA COMPANY** [US/US];
One Coca-Cola Plaza, NW, Atlanta, Georgia 30313 (US).

(72) Inventors: **DE VREESE, Bert**; Chaussee de Mons 1424,
1070 Brussels (BE). **DE PAEPE, Jan**; Hogenakker-
hoekstraat 21, 9150 Kruibeke (BE). **VANDERVELDEN,
Stefan**; Hogenakkerhoekstraat 21, 9150 Kruibeke (BE).

MEURIS, Johan; Hogenakkerhoekstraat 21, 9150
Kruibeke (BE).

(74) Agent: **WARREN, Daniel J.** et al.; Eversheds Suther-
land (US) LLP, 999 Peachtree Street, NE, Atlanta, Georgia
30309-3996 (US).

(81) Designated States (*unless otherwise indicated, for every
kind of national protection available*): AE, AG, AL, AM,
AO, AT, AU, AZ, BA, BB, BG, BH, BN, BR, BW, BY, BZ,
CA, CH, CL, CN, CO, CR, CU, CV, CZ, DE, DJ, DK, DM,
DO, DZ, EC, EE, EG, ES, FI, GB, GD, GE, GH, GM, GT,
HN, HR, HU, ID, IL, IN, IQ, IR, IS, IT, JM, JO, JP, KE,
KG, KH, KN, KP, KR, KW, KZ, LA, LC, LK, LR, LS, LU,
LY, MA, MD, MG, MK, MN, MW, MX, MY, MZ, NA, NG,
NI, NO, NZ, OM, PA, PE, PG, PH, PL, PT, QA, RO, RS,
RU, RW, SA, SC, SD, SE, SG, SK, SL, ST, SV, SY, TH,
TJ, TM, TN, TR, TT, TZ, UA, UG, US, UZ, VC, VN, WS,
ZA, ZM, ZW.

(84) Designated States (*unless otherwise indicated, for every
kind of regional protection available*): ARIPO (BW, CV,
GH, GM, KE, LR, LS, MW, MZ, NA, RW, SD, SL, ST, SZ,

(54) Title: BAG IN BOX CONNECTOR VALVE

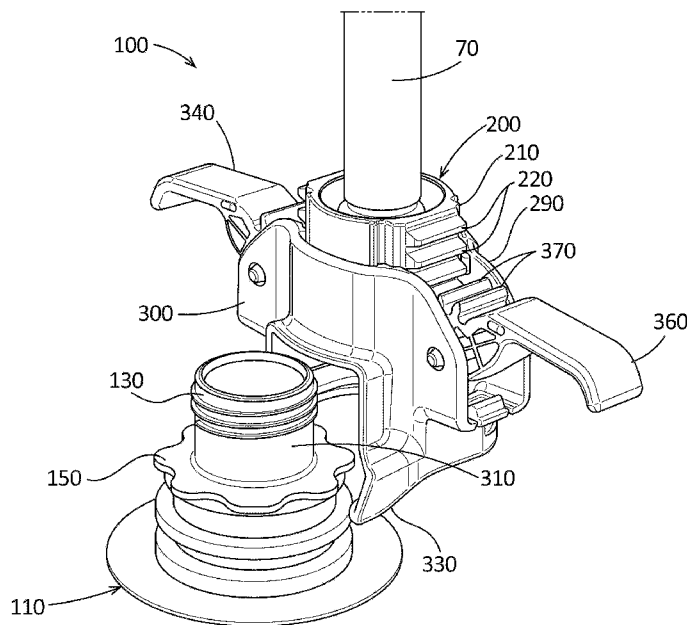

FIG. 3

(57) Abstract: The present application provides a bag in box connection valve for a pouch spout connected to a flexible pouch of a bag in box. The bag in box connection valve may include a ratchet body with a pair of ratchet teeth lines, a quick disconnect ratchet coupling with a spout opening, and a pair of ratchet arms with a pair of ratchet arm teeth lines. The pair of ratchet teeth line and the pair of ratchet arm teeth lines cooperate to raise and lower the ratchet body onto the pouch spout positioned within the spout opening.



TZ, UG, ZM, ZW), Eurasian (AM, AZ, BY, KG, KZ, RU, TJ, TM), European (AL, AT, BE, BG, CH, CY, CZ, DE, DK, EE, ES, FI, FR, GB, GR, HR, HU, IE, IS, IT, LT, LU, LV, MC, ME, MK, MT, NL, NO, PL, PT, RO, RS, SE, SI, SK, SM, TR), OAPI (BF, BJ, CF, CG, CI, CM, GA, GN, GQ, GW, KM, ML, MR, NE, SN, TD, TG).

Declarations under Rule 4.17:

- *as to applicant's entitlement to apply for and be granted a patent (Rule 4.17(ii))*
- *as to the applicant's entitlement to claim the priority of the earlier application (Rule 4.17(iii))*

Published:

- *with international search report (Art. 21(3))*
- *before the expiration of the time limit for amending the claims and to be republished in the event of receipt of amendments (Rule 48.2(h))*

BAG IN BOX CONNECTOR VALVE

CROSS-REFERENCE TO RELATED APPLICATIONS

5 [[0101]] This application claims priority to and benefit of U.S. provisional patent application No. 63/266,372, filed January 4, 2022, which is herein incorporated by reference.

TECHNICAL FIELD

10 [[0102]] The present application and the resultant patent relate generally to beverage dispensing systems and more particularly relate to an improved bag in box connector valve that is easy to attach to a bag in box, that is easy to use, and that is easy to remove.

BACKGROUND OF THE INVENTION

15 [[0103]] Bag in box container are ubiquitous in the field of beverage dispensing. Generally described, syrups, concentrates, or other fluids are positioned within a flexible pouch, typically a five gallon pouch. The pouch is positioned within corrugated box. The bag in box container may be shipped to retail outlet such as restaurants, gas stations, mini-marts, and the like. The corrugated box may be opened and the flexible pouch may be attached to a hose leading to a beverage dispenser and the like. The personnel in the retail outlet may be responsible for attaching and replacing the bag in box containers on a daily basis.

20 [[0104]] There is a desire to adapt existing bag in box technology for use in smaller volume venues. In this scenario, the bag in box container may have a smaller volume of fluid therein. Moreover, the customers who use such bag in box containers may not have much familiarity on how to attach and replace such containers to the beverage dispenser.

SUMMARY OF THE INVENTION

30 [[0105]] The present application and the resultant patent thus provide a bag in box connection valve for a pouch spout connected to a flexible pouch of a bag in box. The bag in box connection valve may include a ratchet body with a pair of ratchet teeth lines, a quick disconnect ratchet coupling with a spout opening, and a pair of ratchet arms with a pair of ratchet arm teeth lines. The pair of ratchet teeth line and the pair of ratchet arm

teeth lines cooperate to raise and lower the ratchet body onto the pouch spout positioned within the spout opening.

5 [0106] attaching a quick disconnect ratchet coupling to a valve housing of a flexible pouch. The method may include the steps of sliding the quick disconnect ratchet coupling over the valve housing, aligning the quick disconnect ratchet coupling in place with the valve housing positioned between a pair of connector arms, and swinging a pair of ratchet arms of the quick disconnect ratchet coupling to drive a valve body of the quick disconnect ratchet coupling into communication with the valve body.

10 [0107] These and other features and improvements of the present application and the resultant patent will become apparent to one of ordinary skill in the art upon review of the following detailed description when taken in conjunction with the shown drawings and the appended claims.

BRIEF DESCRIPTION OF THE DRAWINGS

15 [0108] Fig. 1 is a partial perspective view of a known bag in box container and valve.

 [0109] Fig. 2 is sectional view of the bag in box connector valve as may be described herein.

20 [0110] Fig. 3 is a perspective view of the bag in box connector valve of Fig. 2 in the open position.

 [0111] Fig 4 is a perspective view of the bag in box connector valve of Fig. 2 in the closed position.

DETAILED DESCRIPTION

25 [0112] Referring now to the drawings in which like numbers refer to like elements throughout the several views, Fig. 1 shows an example of a known bag in box container 10. As described above, the bag in box container 10 may have a volume of a fluid 20 positioned in a flexible pouch 30. The flexible pouch 30 is placed in a corrugated box 40 and the like. A bag spout 50 may be attached to the flexible pouch 30. The bag spout 50
30 may be mated with a quick disconnect coupling 60. The quick disconnect coupling 60 generally screws onto the bag spout 50. The quick disconnect coupling 60 may be attached to a hose 70 that is in communication with a beverage dispenser and the like.

5 [[0113]] Figs. 2-4 show an example of an improved bag in box connector valve 100 as may be described herein. The bag in box connector valve 100 may be used with the bag in box container 10 described above and with similar types of containers. The bag in box container 10 may have any suitable size, shape, and configuration. The bag in box container 10 and the bag in box connector valve 100 may be used with any type of fluid therein.

10 [[0114]] The bag in box connector valve 100 may include the bag spout 50 or similar types of spouts attached to the flexible pouch 30. The bag spout 50 may include a valve housing 110. The valve housing 110 may include a bottom chamber 120, an upper chamber 130, an internal stem 140 extending therebetween, and an outer connection flange 150. A bottom assembly 160 with a bottom assembly stem 170 and a poppet valve 180 with a poppet stem 190 may be position in the bottom chamber 120 of the bag spout 50 with the poppet stem 190 extending through the internal stem 140. Other components and other configurations may be used herein.

15 [[0115]] The bag in box connector valve 100 may include a quick disconnect ratchet coupling 200. The quick disconnect ratchet couple 200 may include a ratchet body 210. The ratchet body 210 may be largely tubular in shape and may include a first line of ratchet body teeth 220 on one side and a second line of ratchet body teeth 230 on an opposite side. A valve body 240 may be positioned within the ratchet body 210. The valve body 240 may have an internal pathway 250 with a valve poppet 260 biased by a coil spring 270 and the like. The internal pathway 250 may lead to a stem 280 for connection with the hose 70.

25 [[0116]] The quick disconnect ratchet coupling 200 may include a first side plate 290 and a second side plate 300. The first side plate 290 may be substantially flat. The second side plate 300 may have a spout opening 310 formed therein and a pair of lower connector arms, a first connector arm 320 and a second connector arm 330. The spout opening 310 may be configured to accommodate the upper chamber 130 of the valve housing 110 therein. The connector arms 320, 330 may be configured to accommodate the outer connection flange 150 of the valve housing 110 therein.

30 [[0117]] The quick disconnect ratchet coupling 200 further may include a pair of ratchet arms, a first ratchet arm 340 with a first line of ratchet arm teeth 350 and a second ratchet arm 360 with a second line of ratchet arm teeth 370. The ratchet arm teeth 350, 370 are configured to cooperate with the ratchet body teeth 220, 230 of the ratchet body

210 to raise and lower the ratchet body 210. Other components and other configurations may be used herein.

5 ~~[0118]~~ In use, the valve housing 110 of the bag spout 50 is connected to the flexible pouch 30 and the quick disconnect ratchet coupling 200 is connected to the hose
70. The quick disconnect ratchet coupling 200 is slid over the valve housing 110 and aligned in place via the outer connection flange 150 of the valve housing 110 sliding into place within the connector arms 320, 330 of the quick disconnect ratchet coupling 200. The ratchet arms 340, 360 may be swung upward so as to drive the valve body 240 of the ratchet body 210 downwards. This motion forces the valve body 240 against the poppet stem 190 of the poppet valve 180 so as to raise the valve poppet 260 of the valve body 240
10 and open the internal pathway 250. The fluid 20 from the flexible pouch 30 may now flow through the hose 70 to the beverage dispenser or elsewhere. The quick disconnect ratchet couple 200 may be disengaged from the valve housing 110 by lowering the ratchet arm 340, 360.

15 ~~[0119]~~ It should be apparent that the foregoing relates only to certain embodiments of the present application and the resultant patent. Numerous changes and modifications may be made herein by one of ordinary skill in the art without departing from the general spirit and scope of the invention as defined by the following claims and the equivalents thereof.

CLAIMS

We claim:

1. A bag in box connection valve for a pouch spout connected to a flexible pouch of a bag in box, comprising:

a ratchet body;

the ratchet body comprising a pair of ratchet teeth lines;

a quick disconnect ratchet coupling;

the quick disconnect ratchet coupling comprising a spout opening; and

a pair of ratchet arms with a pair of ratchet arm teeth lines;

wherein the pair of ratchet teeth lines and the pair of ratchet arm teeth lines cooperate to raise and lower the ratchet body onto the pouch spout positioned within the spout opening.

2. The bag in box connection valve of claim 1, further comprising a valve body positioned within the ratchet body.

3. The bag in box connection valve of claim 2, wherein the valve body comprises an internal pathway with a valve poppet.

4. The bag in box connection valve of claim 3, wherein the valve poppet is biased by a coil spring.

5. The bag in box connection valve of claim 3, wherein the internal pathway leads to a stem.

6. The bag in box connection valve of claim 1, wherein the quick disconnect ratchet coupling comprises a first side plate and a second side plate.

7. The bag in box connection valve of claim 6, wherein the second side plate comprises the spout opening with a first connector arm and a second connector arm.

8. The bag in box connection valve of claim 7, wherein the first connector arm and the second connector arm are spaced apart to accommodate a valve housing of the spout therein.

9. The bag in box connection valve of claim 8, wherein the valve housing comprises a poppet valve therein.

10. A method of attaching a quick disconnect ratchet coupling to a valve housing of a flexible pouch, comprising:

sliding the quick disconnect ratchet coupling over the valve housing;

aligning the quick disconnect ratchet coupling in place with the valve housing positioned between a pair of connector arms; and

swinging a pair of ratchet arms of the quick disconnect ratchet coupling to drive a valve body of the quick disconnect ratchet coupling into communication with the valve body.

1/4

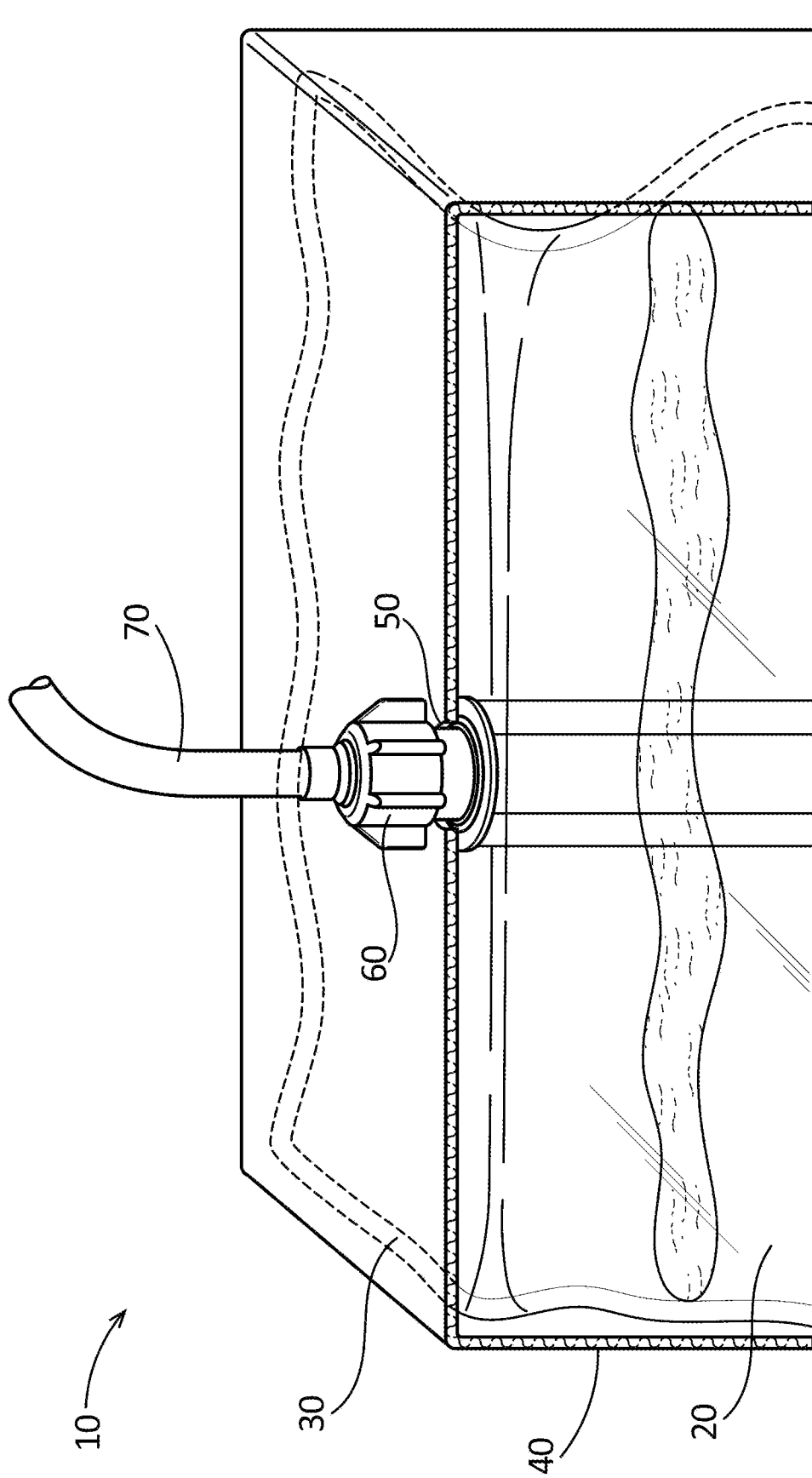

FIG. 1

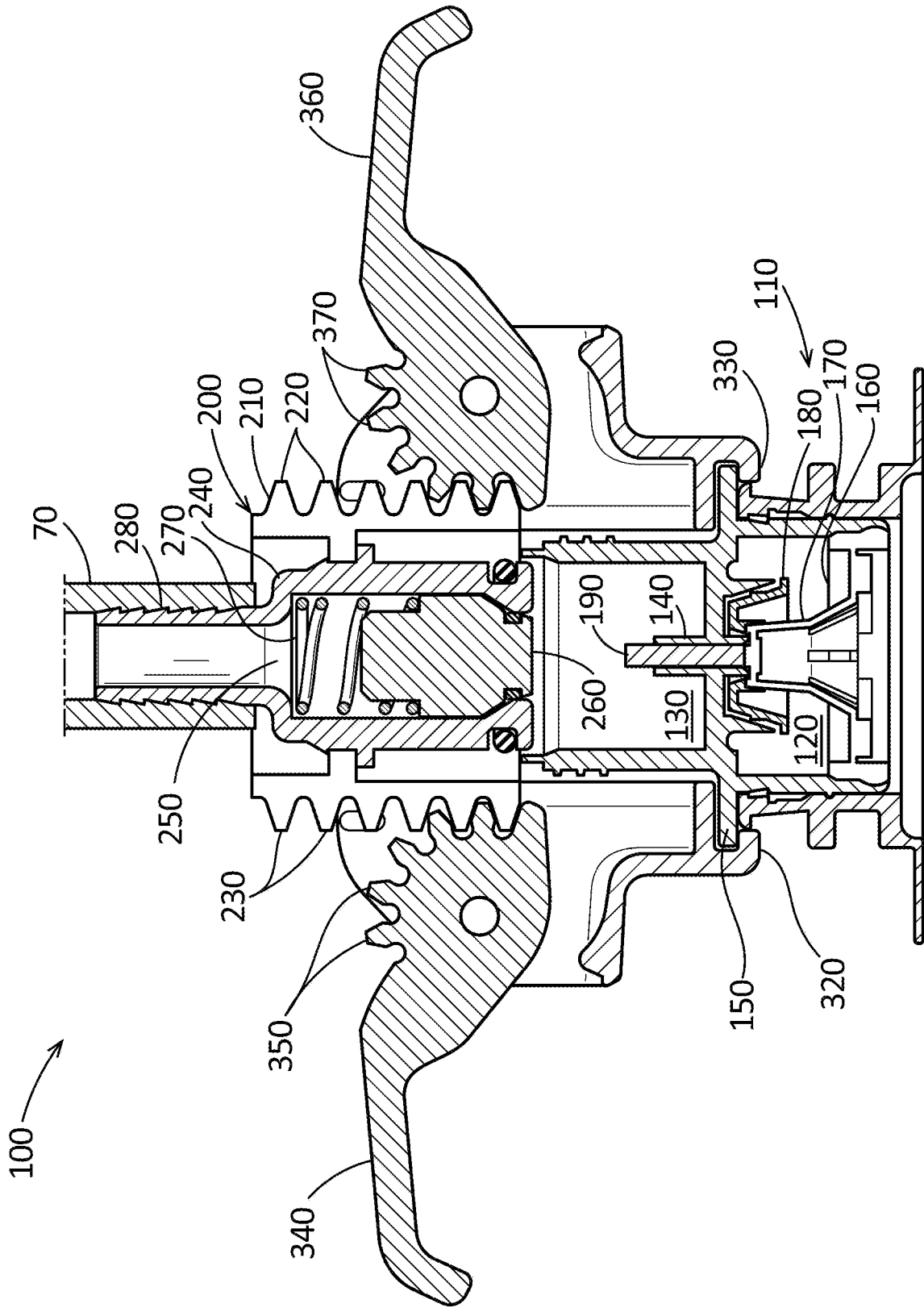

FIG. 2

3/4

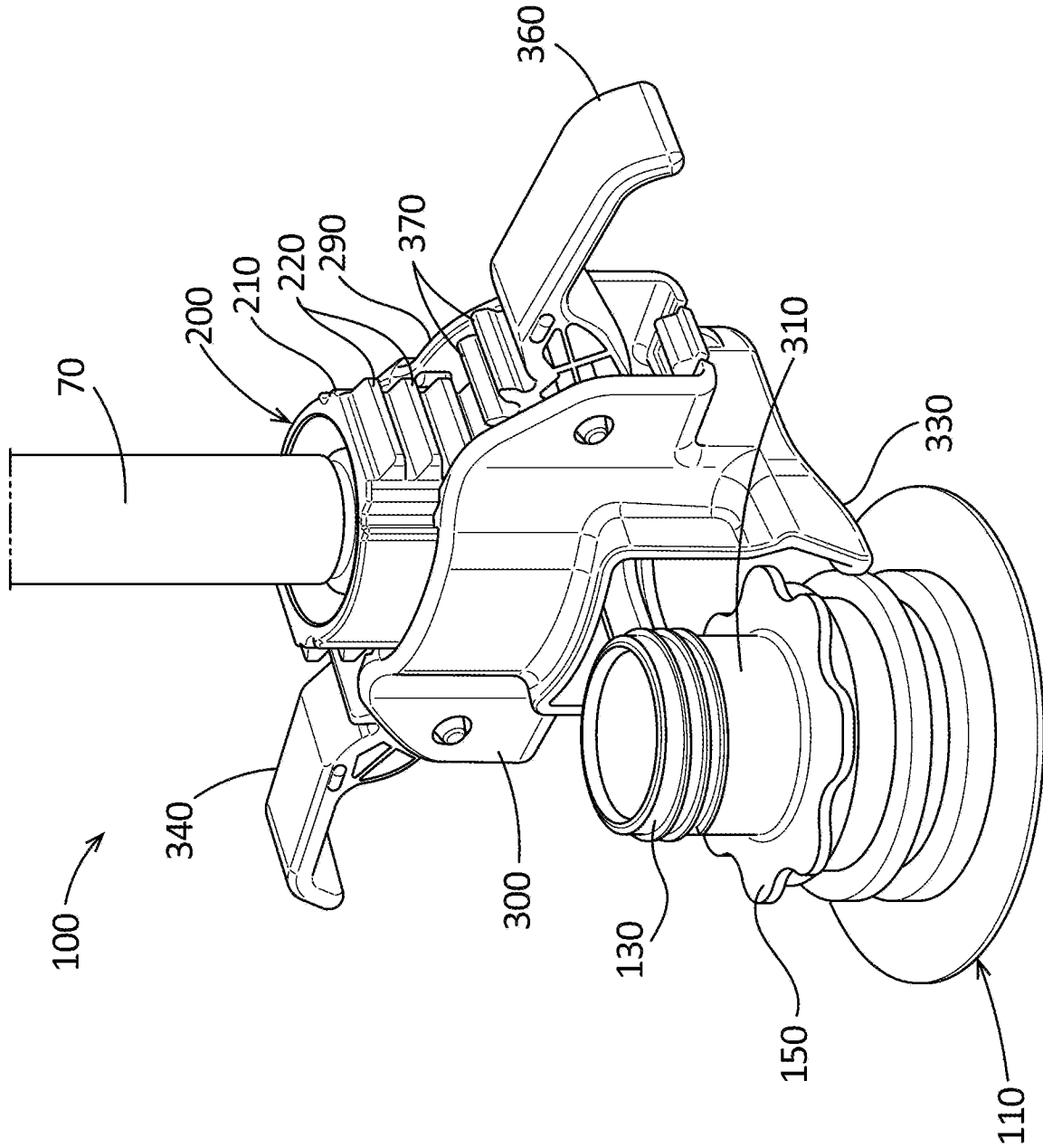

FIG. 3

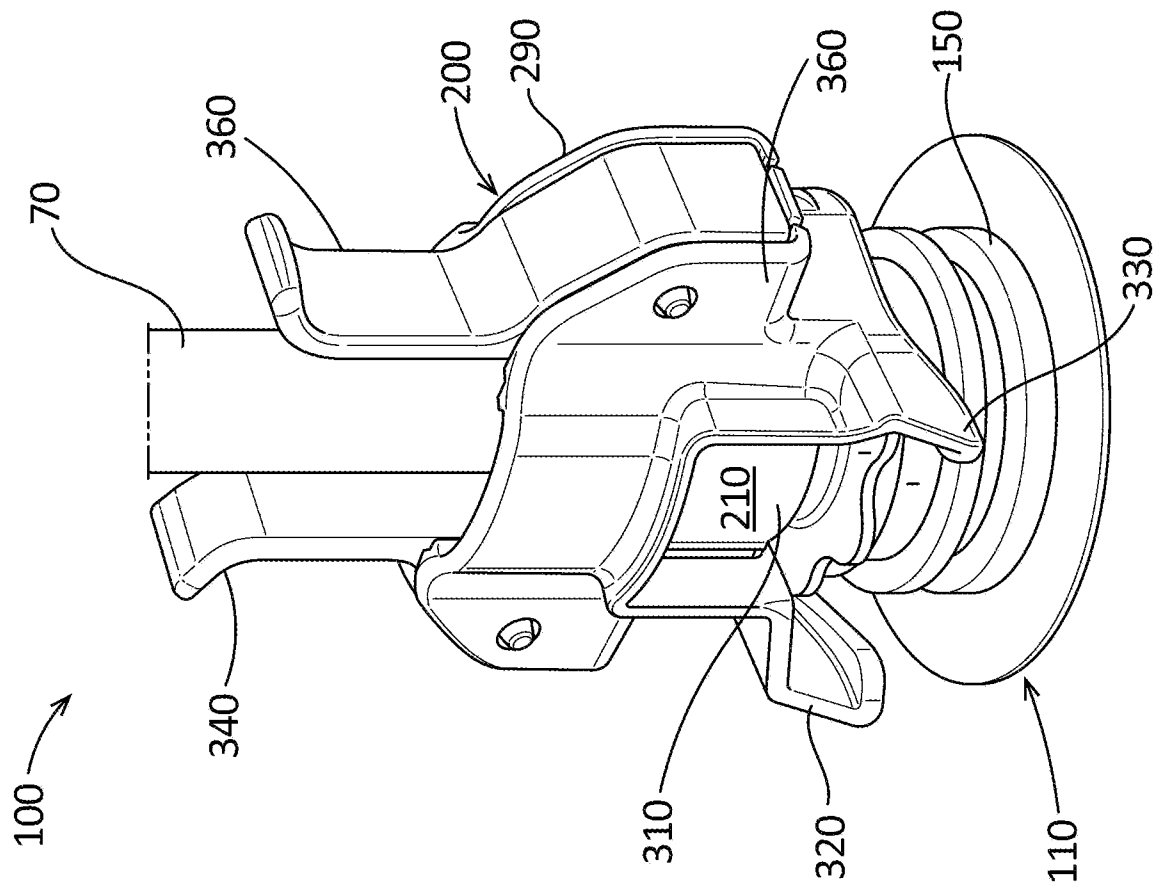

FIG. 4

INTERNATIONAL SEARCH REPORT

International application No.

PCT/US2023/010017

A. CLASSIFICATION OF SUBJECT MATTER		
B65D 77/06(2006.01)i; B65D 25/42(2006.01)i; B65D 5/74(2006.01)i		
According to International Patent Classification (IPC) or to both national classification and IPC		
B. FIELDS SEARCHED		
Minimum documentation searched (classification system followed by classification symbols) B65D 77/06(2006.01); B65B 3/04(2006.01); B67D 7/36(2010.01); F16L 21/00(2006.01); F16L 33/30(2006.01); F16L 37/12(2006.01); F16L 37/18(2006.01); F16L 37/23(2006.01)		
Documentation searched other than minimum documentation to the extent that such documents are included in the fields searched Korean utility models and applications for utility models Japanese utility models and applications for utility models		
Electronic data base consulted during the international search (name of data base and, where practicable, search terms used) eKOMPASS(KIPO internal) & Keywords: bag in box, valve, ratchet, quick disconnect, coupling, arm, teeth line		
C. DOCUMENTS CONSIDERED TO BE RELEVANT		
Category*	Citation of document, with indication, where appropriate, of the relevant passages	Relevant to claim No.
Y	US 4421146 A (BOND et al.) 20 December 1983 (1983-12-20) column 3, line 20 - column 6, line 15 and figures 1-9	1-10
Y	JP 06-123392 A (NIPPON KAYAKU CO., LTD.) 06 May 1994 paragraphs [0017]-[0019] and figures 1-2	1-10
A	US 2020-0318768 A1 (ENGINEERED CONTROLS INTERNATIONAL, LLC) 08 October 2020 (2020-10-08) paragraphs [0027]-[0040] and figures 1-16	1-10
A	US 2019-0063657 A1 (MUELLER INTERNATIONAL, LLC) 28 February 2019 (2019-02-28) paragraphs [0033]-[0039] and figures 1-5	1-10
A	CN 204962124 U (ANHUI LINE ELECTRIC PUMP CO., LTD.) 13 January 2016 (2016-01-13) claims 1-2 and figure 1	1-10
<input type="checkbox"/> Further documents are listed in the continuation of Box C. <input checked="" type="checkbox"/> See patent family annex.		
* Special categories of cited documents: "A" document defining the general state of the art which is not considered to be of particular relevance "D" document cited by the applicant in the international application "E" earlier application or patent but published on or after the international filing date "L" document which may throw doubts on priority claim(s) or which is cited to establish the publication date of another citation or other special reason (as specified) "O" document referring to an oral disclosure, use, exhibition or other means "P" document published prior to the international filing date but later than the priority date claimed "T" later document published after the international filing date or priority date and not in conflict with the application but cited to understand the principle or theory underlying the invention "X" document of particular relevance; the claimed invention cannot be considered novel or cannot be considered to involve an inventive step when the document is taken alone "Y" document of particular relevance; the claimed invention cannot be considered to involve an inventive step when the document is combined with one or more other such documents, such combination being obvious to a person skilled in the art "&" document member of the same patent family		
Date of the actual completion of the international search 27 April 2023		Date of mailing of the international search report 28 April 2023
Name and mailing address of the ISA/KR Korean Intellectual Property Office 189 Cheongsa-ro, Seo-gu, Daejeon 35208, Republic of Korea Facsimile No. +82-42-481-8578		Authorized officer PARK, Tae Wook Telephone No. +82-42-481-3405

INTERNATIONAL SEARCH REPORT
Information on patent family members

International application No.

PCT/US2023/010017

Patent document cited in search report			Publication date (day/month/year)	Patent family member(s)			Publication date (day/month/year)
US	4421146	A	20 December 1983	AT	42932	T	15 May 1989
				AU	1015383	A	18 May 1983
				AU	552437	B2	29 May 1986
				CA	1178988	A	04 December 1984
				DK	161695	B	05 August 1991
				DK	161695	C	27 January 1992
				DK	315883	A	08 July 1983
				EP	0093157	A1	09 November 1983
				EP	0093157	A4	10 June 1985
				EP	0093157	B1	10 May 1989
				IS	1292	B6	07 July 1987
				IS	1293	B6	07 July 1987
				IS	2765	A7	10 May 1983
				JP	58-501858	A	04 November 1983
				NO	156367	B	01 June 1987
				NO	156367	C	09 September 1987
				NO	832506	L	08 July 1983
				NZ	202381	A	14 March 1986
				US	4421146	B1	17 February 1998
				US	4445551	A	01 May 1984
				WO	83-01605	A1	11 May 1983
				ZA	828197	B	26 October 1983
<hr/>							
JP	06-123392	A	06 May 1994	None			
<hr/>							
US	2020-0318768	A1	08 October 2020	EP	3948043	A1	09 February 2022
				US	11460136	B2	04 October 2022
				US	2022-0412494	A1	29 December 2022
				WO	2020-206123	A1	08 October 2020
<hr/>							
US	2019-0063657	A1	28 February 2019	US	10422461	B2	24 September 2019
<hr/>							
CN	204962124	U	13 January 2016	None			
<hr/>							