

N. D. HOSLEY.
FALL BOARD FOR HORIZONTAL GRAND PIANOS.
APPLICATION FILED APR. 28, 1909.

998,178.

Patented July 18, 1911.

2 SHEETS—SHEET 1.

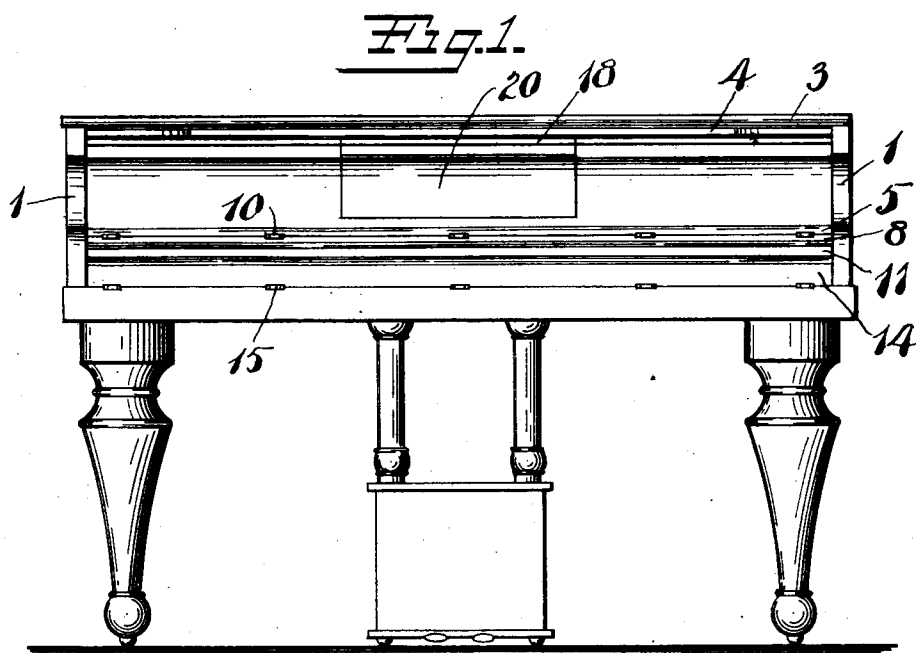

Witnesses:
Chas. A. Reed
Edw. M. Dammeyer

Inventor
N. D. Hosley
By *his Attorneys*
Carroll Dammeyer & Threlkeld

N. D. HOSLEY.
 FALL BOARD FOR HORIZONTAL GRAND PIANOS.
 APPLICATION FILED APR. 28, 1909.

998,178.

Patented July 18, 1911.

2 SHEETS—SHEET 2.

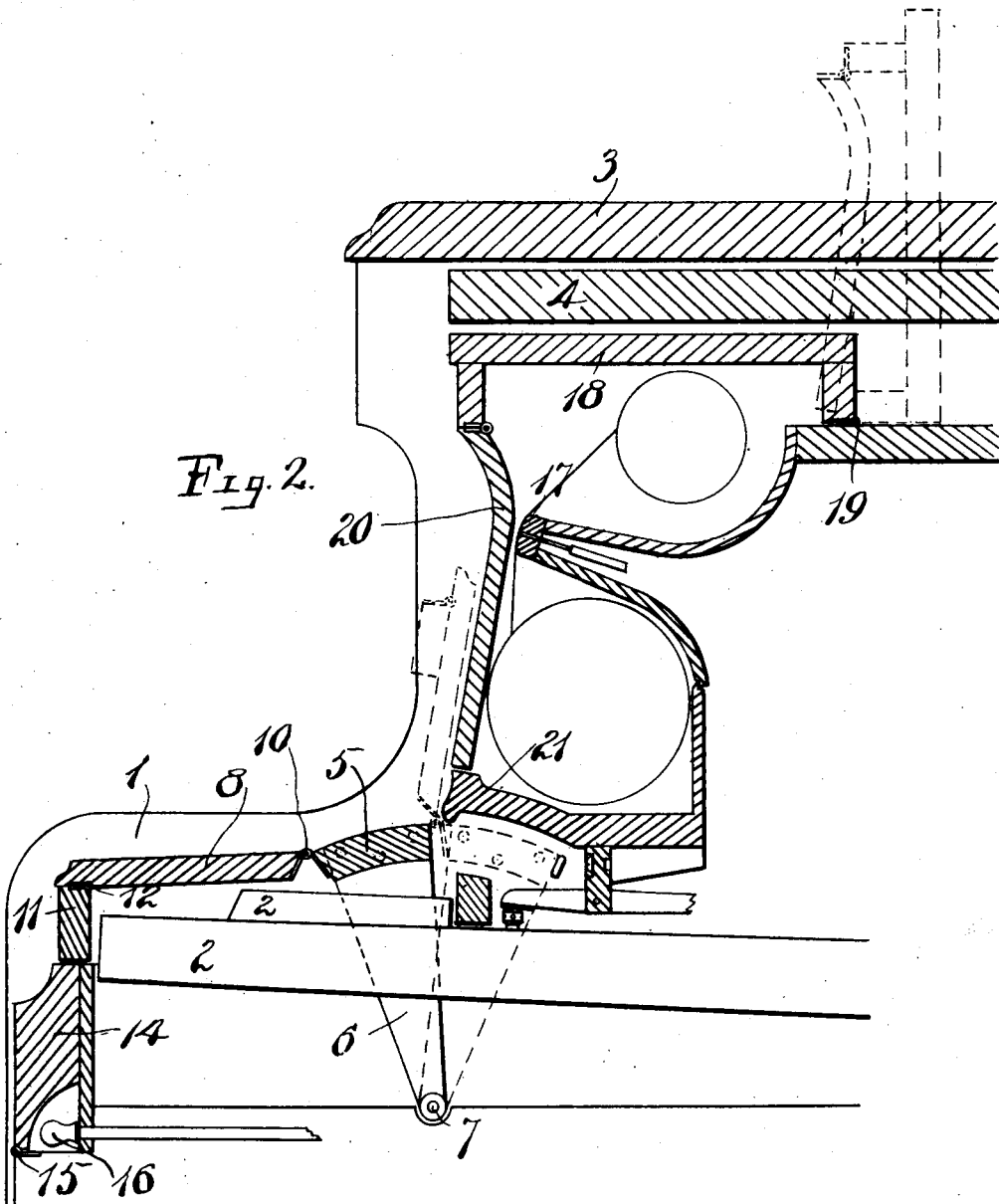

Fig. 2.

Witnesses:
Chas. Reed
Fred. M. Damminger

Inventor
N. D. Hosley
 By *his Attorneys*
Robert Bernard Nathan

UNITED STATES PATENT OFFICE.

NELSON D. HOSLEY, OF MERIDEN, CONNECTICUT, ASSIGNOR TO THE WILCOX & WHITE COMPANY, OF MERIDEN, CONNECTICUT, A CORPORATION OF CONNECTICUT.

FALL-BOARD FOR HORIZONTAL GRAND PIANOS.

998,178.

Specification of Letters Patent. Patented July 18, 1911.

Application filed April 28, 1909. Serial No. 492,645.

To all whom it may concern:

Be it known that I, NELSON D. HOSLEY, a citizen of the United States, residing at Meriden, county of New Haven, State of Connecticut, have invented certain new and useful Improvements in Fall-Boards for Horizontal Grand Pianos, of which the following is a full, clear, and exact description.

My invention relates to improvements in player pianos of the horizontal grand type and has for its object to provide an improved fall-board construction, particularly adapted for use in connection with instruments provided with tracker mechanism adjacent to the upper front panel directly to the rear of the case.

In the accompanying drawings Figure 1 is a front view of a portion of a grand piano, illustrating mainly the location of the tracker cover. Fig. 2 is a relatively enlarged view of certain parts, said view being mainly in section.

1 represents one of the so-called cheek pieces of the piano frame, provided at the ends of the keyboard.

2--2 represent keys.

3 represents the top or lid of the piano which is adapted to fold back in the usual manner.

4 represents the music desk, which is adapted to slide back in the usual manner in a horizontal grand piano.

The fall-board is constructed of several parts, the part 5 being in the particular form shown mounted on end brackets 6 pivoted at 7 to a suitable part of the piano case or frame whereby said section 5 of the fall-board may be oscillated to and fro for the purpose hereinafter described. 8 represents the flap portion of said fall-board, hinged at 10 to section 5 and adapted to be turned up and down.

11 is a front strip preferably hinged at 12 to the section 8 of the fall-board, the parts 5, 8 and 11 operating to close in the keyboard.

14 is what is called the key strip; in this instance, said key strip is hinged at 15 whereby it may be turned down to expose suitable expression controlling devices 16.

While the drawing, Fig. 2 reveals only one of the brackets 6, namely, the bracket at the far end of the part 5, it is obvious that the near end (removed in Fig. 2) is provided with a similar bracket. By reason of the similarity of said brackets, an illustration of one is all that is required for a full understanding.

Directly below the music desk 4 and over and in front of the tracker-board 17 is a cover flap 18 hinged at 19 toward its rear and having a hinged panel 20 at its front, the lower edge of said panel 20 when the instrument is closed lying closely adjacent to a stationary part 21 to give a finished appearance to the front of the instrument when closed.

When it is desired to operate the instrument mechanically, the lid 3 is turned back and the music desk 4 is slid back in the usual manner sufficiently far to permit the parts 18 and 20 to be folded back to approximately the position indicated in dotted lines. The fall-board is then opened; this opening movement involving the lifting of the parts 8 and 11 and the moving back of the section 5 and the turning up of the sections 8 and 11 to the position indicated in dotted lines; the front strip 11 folding down upon the under side of said section 8, as the dotted lines indicate. By this arrangement the upper edge of the fall-board when open stands sufficiently below the tracker-board 17 to permit the operator to readily see the note sheet as it traverses the tracker for the purpose of observing the perforations or expression markings such as may be contained upon the surface of the note sheet for the guidance of the operator.

As shown, the part 20 is a central portion of the front panel and should be of sufficient length to afford ready access to the tracker

and to permit the insertion and removal of
note sheets.

What I claim is:

5 In a piano, a frame, a keyboard, a cover
hinged together longitudinally, a bracket
support connected to the innermost of said
cover parts and supporting the same, and a
pivotal support on said frame for said

10 bracket support to permit the innermost of
said cover parts to be oscillated to and fro,
the outermost cover part being free to be
swung to an upright position.

NELSON D. HOSLEY.

Witnesses:

FRANK C. WHITE,
L. A. KUHULE.

Copies of this patent may be obtained for five cents each, by addressing the "Commissioner of Patents,
Washington, D. C."