

APPARATUS FOR PRODUCING FIBROUS STRUCTURES

Filed June 28, 1968

Fig. 2.

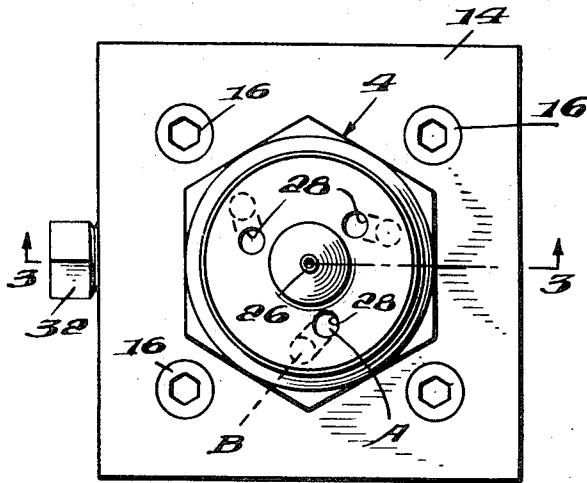

Fig. 1.

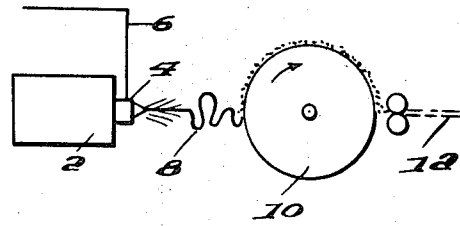

Fig. 3.

Fig. 4.

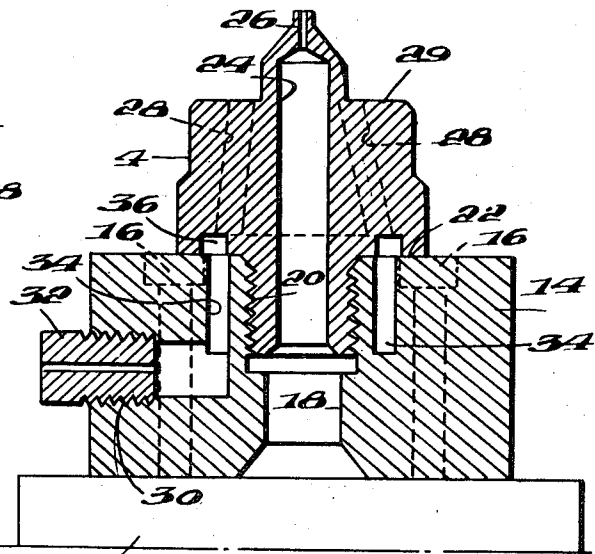
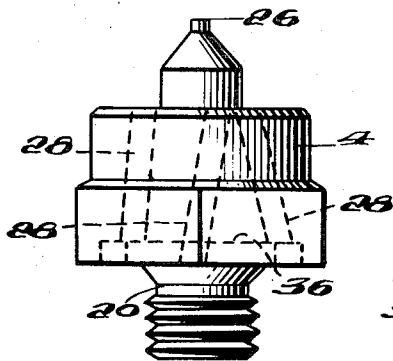
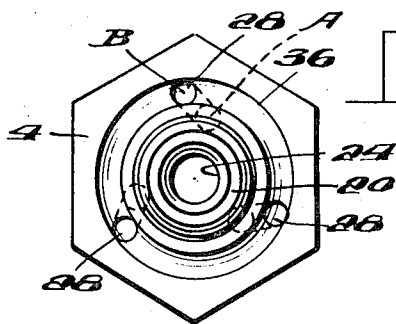

Fig. 5.



1

3,543,332

APPARATUS FOR PRODUCING FIBROUS STRUCTURES

William Sherwood Wagner, Berkeley Heights, N.J., and John Drew Roberts, Charlotte, N.C., assignors to Celanese Corporation, New York, N.Y., a corporation of Delaware

Continuation-in-part of application Ser. No. 581,075, Sept. 21, 1966. This application June 28, 1968, Ser. No. 740,913

Int. Cl. D01d; B29d 23/08

U.S. Cl. 18-8

4 Claims

ABSTRACT OF THE DISCLOSURE

Apparatus and method for producing filamentary material by extruding substantially axially through an orifice comprising contacting the extruded filament stream downstream of the orifice and prior to hardening with a plurality of high velocity gas streams, each moving in a direction having a major component in the direction of extrusion of the filament stream in a shallow angle of tangential convergence therewith to attenuate the filament stream.

This application is a continuation-in-part of U.S. application Ser. No. 581,075; for William Sherwood Wagner and John Drew Roberts; filed Sept. 21, 1966 and now abandoned.

BACKGROUND OF THE INVENTION

This invention relates to the production of filamentary materials. It is concerned particularly with novel apparatus for spray spinning molten fiber-forming polymers.

Various proposals have been advanced heretofore in connection with integrated systems for forming fibrous assemblies, such as non-woven fabrics and the like, directly from molten fiber-forming materials. In general, the proposed systems envisioned an extrusion operation followed by collection of the extruded filamentary material in the form of a continuous fabric, web or other desired fibrous assembly. When details are considered, however, the various proposals differed in substantial ways.

The present invention also is concerned with the direct production of filamentary materials. A basic objective of the invention is to provide improved methods and apparatus for spray spinning molten fiber-forming materials at high production rates and without forming shot or objectionably short fibers which would detract from the desirability of the collected fibrous assembly.

In accordance with an embodiment of the invention, spinning nozzle means are provided with an extrusion orifice for the fiber-forming material and with a plurality of gas outlet passages spaced apart about the extrusion orifice to supply jets of high velocity gas for contacting the extruded filament stream prior to hardening of the filament. The directions of the gas jets are such that substantial drag forces are applied to the extruded filament stream in the direction of extrusion for attenuating or drawing the material leaving the extrusion orifice. Further, the gas passages are inclined so that their axes do not intersect the axis of the extrusion orifice. These directional characteristics have been found to be particularly significant in preventing the formation of shot and preventing freeze-ups of the extrusion nozzle. They also serve to permit achievement of the desired high rate of production of filamentary materials in which the filaments are substantially continuous.

2

While still in the zone of influence of the gas streams, the filament is deposited on collector means that preferably moves continuously. The gas flow swirls the filament sections about in a random expanding conical pattern and they reach the collector while their surfaces are somewhat tacky so that sufficient self bonding occurs to preserve to a substantial extent the relationships established at the time of deposit on the collector. These relationships may include interesting three-dimensional effects contributing significantly to product bulk.

DESCRIPTION OF THE DRAWINGS

A more complete understanding of these and other features of the invention will be gained from a consideration of the following detailed description of an embodiment illustrated in the accompanying drawings in which:

FIG. 1 is a schematic view illustrating the major components of a system for producing filamentary materials in accordance with the invention;

FIG. 2 is a front elevational view of the nozzle and adapter of FIG. 1;

FIG. 3 is a cross sectional view of the nozzle and adapter along the line 3-3 in FIG. 2;

FIG. 4 is a side elevational view of the nozzle; and

FIG. 5 is a rear elevational view showing the threaded end of the nozzle.

The invention may be used in connection with the production of products from any of the various materials that may be melted and extruded through an orifice to form a filament. Examples of suitable types of fiber-forming materials are preferably organic fiber-forming materials such as polyolefins, polyamides, polyesters, cellulose acetate, polyvinyl acetate, poly(methyl methacrylate), styrene copolymers, and the like. Polyolefins such as polyethylene and polypropylene, and polyamides such as nylon 66, have sufficiently low melt temperatures and sufficiently low melt viscosities, and they are therefore particularly convenient to use. Even materials which are normally difficult to melt without decomposition, such as cellulose acetate, may be used by adding a high boiling plasticizer as a melt depressant, if necessary. Inorganic fibers such as glass can also be spun using the present apparatus and process but are normally less preferable.

Referring to FIG. 1, the fiber-forming material is heated in an extruder 2, and is extruded through nozzle means 4. Steam or other heated gas is supplied to the nozzle means 4 through a separate steam line 6, and the steam is directed outwardly from the nozzle to surround the filament 8 issuing from the nozzle. The filament 8 is projected by the gas to the surface of a rotating collecting drum 10. The filament 8 may not be completely solidified when it reaches the drum and points of intersection of the filament are joined together by self-bonding to form a mat 12. Of course, the distance between the drum 10 and the nozzle means 4 affects the extent of self-bonding in the mat. The mat 12 may be formed by entanglement of portions of the filament on the surface of the drum without self-bonding, if desired. The product 12 may be used as such, or it may be subjected to various treatments, such as calendering, needling, compressing, impregnation with latex or other filler, or embossing to form various structures.

The nozzle 4 is supported on an adapter 14 which is secured over the outlet of the extruder 2 by screws 16. The adapter 14 has a central opening 18 through which the molten fiber-forming material is conducted to the nozzle. The passage 18 is internally threaded at the end opposite the extruder to receive a threaded shank 20 on the nozzle 4. The screw threads on the shank portion 20 and

in the passageway 18 cooperate to clamp the base 22 of the nozzle tightly against the face of the adapter 14.

The nozzle has a central passage 24 which terminates in an extrusion orifice 26 through which the fiber-forming material is extruded. The nozzle 4 also has a plurality of gas outlet passages 28 which are spaced around the central passage 24. Each of the gas passages 28 is inclined and is as long as is necessary for directing the gas in the desired path. All of the passages 28 preferably are inclined in the same direction with respect to the orifice central axis and they are preferably equally spaced, so that the gas stream issuing from each of the passages 28 has substantially the same effect on the filament stream issuing from the orifice 26.

Gas under pressure is supplied to the passages 28 from the adapter 14. The adapter has a passage 30 which is internally threaded to receive a conventional coupling 32. The passage 30 communicates with an annular header 34. The base 22 of the nozzle 4 has an annular groove 36 which interconnects the ends of the gas passages 28 and which is substantially aligned with the header 34 for distributing gas from the header to the passages 28. The groove 36 communicates with the header 34 regardless of the angular position of the nozzle 4 relative to the adapter 14. Thus, when the base 22 of the nozzle is screwed tightly against the adapter 14, it is not necessary to turn the nozzle 4 to a predetermined angular position in order to establish communication between the source of gas and the passages 28.

In operation, fiber-forming material is heated to a molten state in the extruder 2 and passes through the opening 18 in the adapter and through the passage 24, from which the molten material is extruded through the nozzle 4. At the same time, gas under pressure is conducted through the coupling 32 into the header 34, and from the nozzle groove 36 to the gas passages 28. The gas is preferably heated above the melting temperature of the material being extruded and is compressed to cause substantial expansion of the gas as it passes out of the passages 28. The gas pressure should be high enough to assure that the gas jets issuing from the passages 28 attain velocities sufficiently greater than the extrusion velocity of the filament to enable the gas to exert an attenuating drag on the filament in an axial direction. The gas also swirls the filament 8 about in a random expanding conical pattern in a downstream zone of turbulence, as suggested diagrammatically in FIG. 1. Collection of the filamentary material preferably occurs continuously as the surface of the drum 10 moves through the path of the material projected from the nozzle means 4.

The construction of the nozzle means may take various forms. However, in all cases particularly careful attention should be given to the relationships established between the gas passages and the extrusion orifice. A brief discussion of some of the factors involved will serve as a basis for establishing particular configurations.

It is important that gas flow patterns be established which will not expose the outlet of the extrusion orifice to unnecessary cooling or chilling effects. If the temperature of the fiber-forming material in and just beyond the extrusion orifice is not kept high enough, nozzle freeze-ups and/or the formation of shot will occur. Moreover, we have found that these difficulties cannot be avoided by simply increasing the temperature at which the gas is supplied to the nozzle means. One reason is the practical one that much of the potential energy of the gas will be transformed into kinetic energy in the process of imparting to the gas the high velocity required for attenuating the coarse filament stream issuing from the extrusion orifice. That is to say, the expansion of the gas as it moved through the air passages and into a zone of atmospheric or ambient pressure will necessarily be accompanied by a marked drop in temperature in any truly practical system. Another reason is that too high a gas temperature in the zone where the moving gas is applying attenuating

forces to the filament would reduce the tensile strength of the filament in that zone to such an extent that it would be broken up into undesirably short lengths.

Correlation of these factors is achieved in accordance with the invention by effectively isolating the extrusion orifice from the chilling effects of the gas flow while bringing the gas flow to bear upon the filament stream at a downstream zone. For effective isolation it is important not only that the gas be directed along paths displaced from the extrusion orifice but also that the primary gas paths be such as to avoid the creation of secondary flow patterns capable of producing undesired chilling at the extrusion orifice outlet. It has been found, for example, that gas streams directed along paths the axes of which intersect at the filament stream will create a zone or lobe of turbulent air flow extending back along the filament axis in the upstream direction, and that this secondary flow effect can cause nozzle freeze-ups. Such difficulties have been overcome however through the use of gas passages which are inclined in a distinctive manner.

The nature of the inclination of the several passages 28 shown in the drawings can best be explained by reference to the positions of the points A and B indicated in FIGS. 2 and 5. Point A represents the point of intersection of the central axis of a passage 28 with a plane perpendicular to the axis of the extrusion orifice at the outlet of the passage 28 (e.g., the plane of the face 29 of the nozzle means shown in FIG. 3). Point B represents the point of intersection of the central axis of the passage 28 with another plane perpendicular to the axis of the extrusion orifice at the inlet of the passage 28 (e.g., the plane of the base of the groove 36 in FIG. 3). The inclination of the passage axis is such that the points A and B are displaced angularly with respect to each other about the axis of the extrusion orifice, and the point A is radially closer to the axis of the extrusion orifice than is the point B.

The disposition of the point A closer to the extrusion axis than point B gives the gas passage 28 an inclination component tending to cause convergence of its axis with the extrusion axis at a point in front of and displaced from the nozzle means 4. However, the skew effect stemming from the angular displacement of the points A and B with respect to each other prevents actual intersection of the air passage axis with the extrusion axis. The degree of skew should preferably be great enough to assure that the cylindrical projection of the passage outlet opening along the extended axis of the passage will not substantially overlap or intersect with the cylindrical projection of the extrusion orifice along the extrusion axis.

When the gas passages are skewed in this fashion, it becomes possible for the high velocity gas streams issuing therefrom to apply the desired attenuating forces to the filament downstream of the extrusion orifice without creating those secondary flow effects, such as turbulence lobes extending back to the orifice outlet, which would result in nozzle freeze-ups and/or the production of shot.

SUMMARY OF THE INVENTION

More specifically, the spray-spinning nozzle which is best suited for use with organic thermoplastic fiber-forming polymers is designed to attenuate the fibers while still in the plastic state, without excessive fiber breakage. Thus, the fiber is retained substantially as a continuous fiber or long-staple fiber. This is accomplished by attenuating the molten fiber exiting from the extrusion orifice with the jets of gas at a relatively shallow angle of convergence wherein the gas jet tangentially contacts the extruded fiber. The angle of convergence is measured in a first plane containing the orifice axis and a projection of the passage axis. The first plane is defined by the axis of the extrusion orifice 26 and by a line extending perpendicularly to the extrusion orifice axis and passing through the center of the outlet opening A of one of the gas passages. The projection of the gas passage axis on the first plane

intersects the orifice axis, the acute angle of intersection of the projected passage axis and the orifice axis of the nozzle is the convergence angle. This angle is a shallow angle converging toward the fiber axis. The convergence angle preferably ranges from about 3 to 15 degrees and more preferably from about 4 to 7 degrees. However, as noted above, because the axis of the fiber extrusion and the axes of the gas streams are skewed with respect to each other, the respective axes do not actually intersect.

The skew angle is measured in a second plane that includes the orifice axis and is perpendicular to the first plane. The projection of the axis of the gas passage 28 on the second plane intersects the orifice axis. The acute angle of intersection of these lines in the second plane is the skew angle. This angle is between about 1 and 10 degrees, and preferably between 1 and 7 degrees. Therefore, the fiber attenuation is effected by the close proximity of the gas axis to the fiber axis as they pass each other at their closest point. This closest point is called the convergent point.

The distance between the aforementioned axes at the convergent point is referred to as the convergent diameter. The convergent diameter ranges from about 0.5 to 18 millimeters and preferably from about 1 to 10 millimeters. The convergent point occurs at a distance of from about 12 to 126 millimeters from the fiber extrusion orifice. This distance can be varied in accordance with the convergence angle and the skew angle. It will be readily recognized by those skilled in the art that the various measurements noted above are interrelated and therefore the setting of certain angles and distances predetermines certain of the other angles and distances.

Various gas or jet pressures can be utilized in the present invention. For the gas jet dimensions described herein, pressures between about 10 and 100 pounds per square inch gauge are normally used. However, higher or lower pressures can be used, depending upon the particular desired operating conditions, the gas jet openings, the fiber being extruded and the like. Pressures of from about 20 to 25 pounds per square inch gauge have been found to be particularly desirable for organic fibers using the gas jet more specifically described herein.

Of course, in achieving optimum conditions for particular commercial operations due regard must be had for the specific material and processing conditions. The inclinations selected for the non-intersecting axes of the generally converging gas jets may depend for example upon such factors as gas temperature, the velocity attained by the gas, the temperature and melt viscosity of the fiber-forming material, and the deposition pattern at the zone of collection.

The following example will serve to further illustrate the principles of the invention.

EXAMPLE I

In this instance the apparatus shown in the drawings was employed to produce a narrow non-woven fabric made up of substantially continuous filaments.

The nozzle passages had the following dimensions: diameter of extrusion orifice 26, 0.030 inch; diameter of each gas passage 28, 0.082 inch; radial distance between the extrusion axis and the axis of each passage 28 at the point where it intersects the groove 36, 0.290 inch; radial distance between the extrusion axis and the axis of each passage 28 at the outlet end of the passage, 0.197 inch; circumferential displacement of the axis of each passage 28 between the passage inlet and the passage outlet (measured as the perpendicular distance between parallel planes, one of which contains the axis of the extrusion orifice 26 and the point of intersection of the passage axis with the base of the groove 36 and the other of which intersects the passage axis at the outlet end of the passage), 0.084 inch; the distance along the extrusion axis between the outlet of the extrusion orifice and the plane containing the outlets of the gas passages 28, 0.281

inch; and the perpendicular distance between the plane containing the outlets of the gas passages 28 and the plane containing the inlets of the gas passages 28, 0.420 inch.

The angular relationships of the gas passages 28 with respect to the axis of the extrusion orifice 26 were measured graphically. The angle of convergence was 12 degrees and the skew angle was 2 degrees.

Nylon 66 (polymeric condensation product of adipic acid and hexamethylene diamine) was supplied to the extruder. The extruder and adapter were heated to 310° C. and the polymer was melted in the extruder. The speed of the extruder screw was regulated to provide a flow rate of molten polymer of 2 lbs. per hour through the nozzle orifice.

A steam line was connected to the coupling 34 in the adapter 14 and steam was supplied continuously to the nozzle at 350° C. and 40 p.s.i.g.

The collector was in the form of a drum having a smooth metal surface spaced from the extrusion orifice a distance of about 2 ft. It was rotated continuously at a surface speed of 3 ft. per minute to produce a 4 inch wide band.

With the system in operation, the steam jets from the passages 28 attenuated the melt stream of polymer into a continuous filament ranging from approximately 1 to 5 d.p.f. without producing shot. No tendency toward nozzle freeze-up was observed. The filamentary material collected on the drum exhibited a skin effect on the side thereof facing the drum and a loft or bulk effect on the opposite side. The non-woven fabric weighed approximately 5 oz. per square yard. The non-woven fabric had sufficient tensile strength to withstand substantial pulling forces.

It will be understood, of course, that these specific conditions and configurations described in detail herein are exemplary only, and that the invention is susceptible of embodiment in a variety of forms which will be evident to persons skilled in the art from the foregoing.

The embodiments of the invention in which an exclusive property or privilege is claimed are defined as follows:

1. Apparatus for producing organic thermoplastic filamentary material comprising nozzle means having an extrusion orifice for fiber-forming material and a plurality of gas outlet passages spaced from said extrusion orifice and having non-intersecting axes spaced apart about the axis of said extrusion orifice, the axis of each of said gas outlet passages being so inclined that such axis is closer to the axis of the extrusion orifice at the outlet end of the passage than at an interior zone of the passage so as to direct the gas stream in a convergence angle with the axis of the extrusion orifice of from about 3 to 15 degrees and so that the location of the passage axis at the outlet end of the passage is displaced about the axis of the extrusion orifice with respect to the location of the passage axis at an interior zone of the passage so as to form a skew angle of from about 1 to 10 degrees with respect to the axis of the extrusion orifice, means for extruding molten fiber-forming material through said extrusion orifice, and means for supplying said passages with gas under pressure to be projected from said passages to contact and attenuate the stream of fiber-forming material issuing from said extrusion orifice.

2. The apparatus according to claim 1 wherein said nozzle means is provided with at least three of said gas passages and wherein the outlet ends of all of said gas passages are displaced from their inlet ends about the axis of the extrusion orifice in the same circumferential direction.

3. The apparatus according to claim 1 wherein the inclination of the axis of each of said gas passages is such that the projection of the outlet opening along the passage axis approaches without intersecting the projection of the extrusion orifice along its axis.

4. The apparatus according to claim 1 wherein the gas outlet passages are positioned behind the extrusion orifice.

References Cited

UNITED STATES PATENTS

3,436,792	4/1969	Hench.	
3,015,127	1/1962	Stalego.	
3,366,722	1/1968	Tessier.	
3,423,266	1/1969	Davies et al.	
3,441,468	4/1969	Siggel et al.	
2,121,802	6/1938	Kleist et al. -----	49—1
2,331,945	10/1943	Pazsiczky et al.	
2,374,540	4/1945	Hall -----	18—2.5
2,411,660	11/1946	Manning.	
2,437,263	3/1948	Manning.	
2,508,462	5/1950	Marshall -----	18—8

5

10

15

3,266,969	8/1966	Makansi.	
3,282,668	11/1966	Mabru -----	65—12
3,017,664	1/1962	Ladisch -----	18—2.5
3,309,734	3/1967	Bynum et al. -----	264—176
3,379,811	4/1968	Hartmann et al.	

FOREIGN PATENTS

296,015	5/1965	Netherlands.
634,623	1962	Canada.
1,450,274	7/1966	France.

JULIUS FROME, Primary Examiner

J. H. WOO, Assistant Examiner

U.S. Cl. X.R.

18—2.5; 264—12, 210