

Aug. 26, 1969

H. E. WARDEN

3,463,921

X-RAY TABLE EQUIPMENT

Filed June 28, 1967

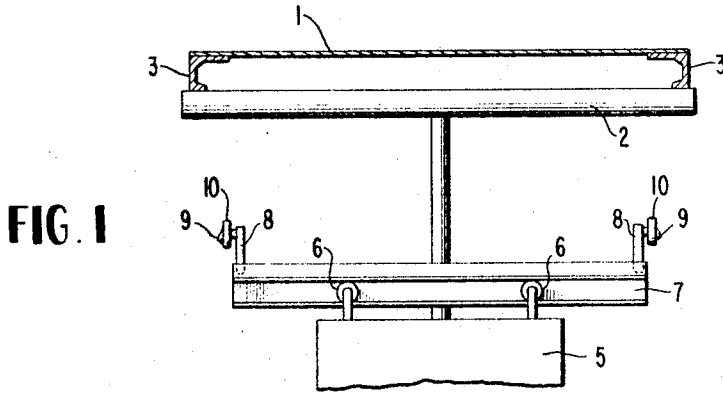

FIG. 1

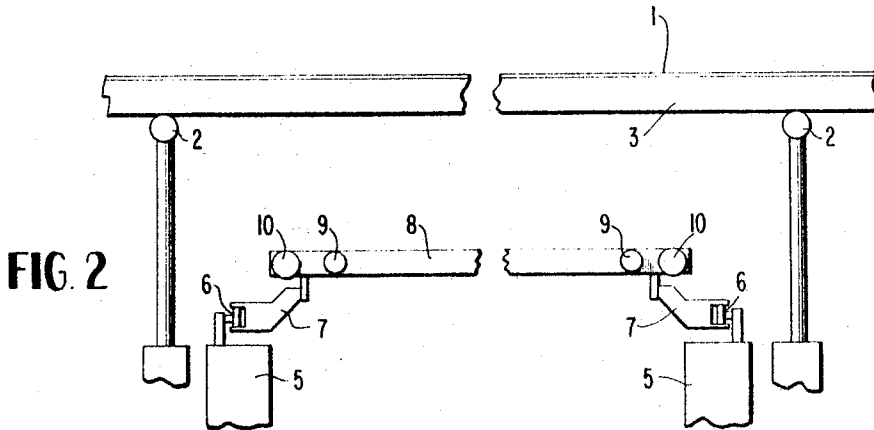

FIG. 2

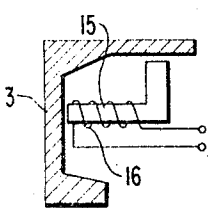

FIG. 3

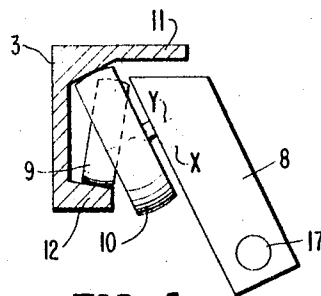

FIG. 4

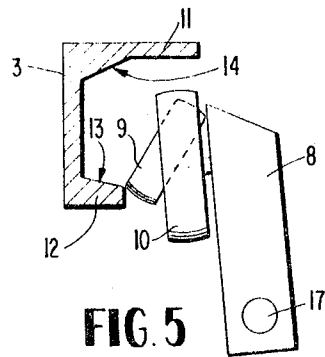

FIG. 5

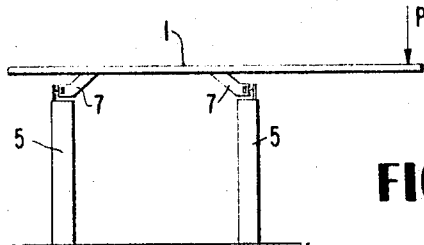

FIG. 6

INVENTOR
HANS ERIK WARDEN

BY *Young & Thompson*

ATTORNEYS

1

2

3,463,921

X-RAY TABLE EQUIPMENT

Hans Erik Warden, Infanterigatan 3, Solna, Sweden

Filed June 28, 1967, Ser. No. 649,634

Claims priority, application Sweden, June 29, 1966,

8,846/66

Int. Cl. G01n 23/00

U.S. Cl. 250—54

5 Claims

ABSTRACT OF THE DISCLOSURE

An X-ray table has a top that is rollably slidable in both horizontal directions on a support. The table top can be readily lifted off and deposited on the supporting structure, because the rolls by which it is supported are vertically swingable into and out of a pair of opposed channels secured to the under side of the table top. The rolls are arranged in pairs whose axes are at an angle to one another to facilitate engagement in the channels.

The present invention relates to X-ray tables with removable and adjustable tops.

In the X-raying of patients, it is often desirable to keep the patient on a horizontal support not only during the taking of the X-rays, but also during transportation to and from the X-ray machine. To this end, it is desirable that there be provided an X-ray table top which may be lifted from and lowered onto a support, and which will also be adjustable in both horizontal directions relative to the support.

In the past, such equipment has comprised a transport carrier which rolls along the floor and carries a table top on which the patient is supported, in combination with a stationary stand adjacent the X-ray machine. When the carrier reaches the X-ray machine, the table top with the patient on it is removed from the carrier and transferred to the stand.

The table tops as known heretofore have had a pair of longitudinal channel sections secured to their lower surface, with the channels supported by rolls mounted on an intermediate carriage. The intermediate carriage in turn has been provided on its lower surface with channel members extending perpendicular to the first-mentioned channel sections. These channel members on the intermediate carriage have been engaged and supported by rolls mounted on the stand, so that the table top with the patient on it could be slid in either horizontal direction on the rolls.

With these earlier arrangements, however, it has been difficult to insert the channels over the rolls when the table top is removed from its carrier to be placed adjacent the X-ray machine. Moreover, it has been necessary to maintain a good deal of waste space in the X-ray room, for aligning the table top with the rolls so that the channels could be slid endwise over the rolls.

In eliminating these and other difficulties and disadvantages of known devices of this type, it is an object of the present invention to provide an X-ray table having a table top that is quickly and easily removable from and replaceable on its support by vertical movement of the table top without the need for moving the table top horizontally.

Another object of the present invention is the provision of an X-ray table which may be horizontally slid to posi-

tions characterized by a large amount of overhang of the table top from the support, without misaligning the parts or impairing the operation of the device.

Still another object of the present invention is the provision of an X-ray table in which the weight of the patient is utilized in order to ensure that the table top is firmly retained on its support.

Finally, it is an object of the present invention to provide an X-ray table which will be relatively simple and inexpensive to construct, easy to assemble, operate, maintain and repair, and rugged and durable in use.

Other objects and advantages of the present invention will become apparent from a consideration of the following description, taken in connection with the accompanying drawing, in which:

FIGURE 1 is a side elevational view of an X-ray table according to the present invention, with a transport carrier that bears the table top in a position raised above the support of the X-ray table;

FIGURE 2 is a view similar to FIG. 1, but with the parts rotated 90° about a vertical axis;

FIGURE 3 is an enlarged fragmentary schematic view of a brake according to the present invention;

FIGURE 4 is an enlarged fragmentary cross-sectional view through one of the channel members of the table top, showing engagement of the supporting rolls in this channel member;

FIGURE 5 is a view similar to FIG. 4, but showing the table top being raised out of engagement with the rolls; and

FIGURE 6 is a somewhat schematic view similar to FIG. 2, but showing the top substantially laterally displaced to illustrate the support of a cantilever-loaded table top.

Referring now to the drawing in greater detail, and first to FIGS. 1 and 2 thereof, there is shown an X-ray table according to the present invention, comprising a flat horizontal table top 1 for the support of a patient thereon. It is intended that the patient rest on table top 1 while being transported to and from the location of the X-ray equipment, and remain on the table top during taking of the X-ray pictures. To this end, therefore, a transport carrier 2 is fragmentarily shown, on which spaced portions of table 1 rest. Transport carrier 2 is itself rollably supported on wheels (not shown) for easy transportation, and is adapted to raise and lower the table top 1 so as selectively to lift table top 1 or deposit it on an underlying support on which it will rest during the taking of the pictures.

Table top 1 is provided with a pair of rigid channel members 3 that extend along each side thereof on the under side of table top 1. Channel members 3 have generally horizontally disposed flanges, so that the channel members open horizontally. In the illustrated embodiment, these channel members 3 are disposed one along each longitudinal side of table top 1 and open toward each other.

A stationary support for the table top is provided, comprising a pair of upright pillars 5, each of which carries a pair of horizontally spaced rolls 6 that are supported on pillars 5 for rotation about spaced parallel horizontal axes.

An intermediate carriage is provided, comprising two oppositely outwardly opening horizontal channel members 7 that are supported on the undersides of their upper flanges for horizontal movement on rolls 6. The channel

members 7 open horizontally in the same plane. Mounted for vertical swinging movement on and relative to the channel members 7 are horizontal beams 8. Beams 8 are perpendicular to channel members 7 and parallel to each other. Beams 8 interconnect the ends of channel members 7, and vice versa.

As best seen in FIG. 2, each beam 8 supports a pair of rolls 9, 10 at each end of beam 8. Roll 9 is of relatively small diameter and roll 10 is of relatively large diameter. The axes of rolls 9 and 10, shown at X and Y, respectively, in FIG. 4, are disposed at an acute angle to each other, preferably about 30-45°. Rolls 9 and 10 are disposed on the outer sides of beams 8.

Each channel member 3 has a pair of generally horizontal flanges 11 and 12, the flange 11 being the upper flange and being of substantially greater horizontal extent than the flange 12. Flange 12 has an upper surface at 13 that inclines upwardly toward the bottom of the channel member. Flange 11 has a lower surface 14 that inclines downwardly toward the bottom of the channel member. The surfaces 13 and 14 thus converge in the direction of the bottom of the channel member and diverge horizontally outwardly in the direction in which the channel member opens.

An electromagnetic brake is provided, which is mounted on at least one of the beams 8. As is best seen in FIG. 3, the electromagnetic brake comprises a movable core 15 and a winding 16, so that upon passage of an electric current from a source (not shown) through winding 16, the core is pressed against the web of channel members 3 thereby to retard the movement of the channel members 3 and their attached table top 1, relative to the beams 8. A similar brake (not shown) can also be provided so as selectively to lock channel members 7 against movement relative to pillars 5.

Beams 8 are pivotally mounted adjacent their ends for vertical swinging movement, by pivots 17 carried by channel members 7. It is particularly to be noted that the axes of vertical swinging movement of the beams 8, which are provided by the pivots 17, are below and transverse to the axes X and Y of the rolls 9 and 10 and parallel to the length of beams 8. The pivots 17 are also spaced horizontally outwardly from the channel members 3 in the direction that the channel members open.

In operation, a supported table top 1 with a patient on it may be lowered from the position of FIGS. 1 and 2, in which the beams 8 are vertically swung, to an upper position somewhat like that in FIG. 5. In this position, the rolls 9 and 10 are closer together than the lower flanges 12 of the channel members 3, so that the channel members 3 pass downwardly on opposite outer sides of the rolls 9 and 10 without interference.

But as the flange 11 of channel members 3 is longer than the flange 12 thereof, flange 11 strikes the larger roll 10 of each of the four roll pairs 9, 10. The flange 11 thus exerts a downward force on roll 10.

This downward force acts in a direction which passes between the channel member 3 and the pivots 17. As a result, the beam 8 tends to swing from the position of FIG. 5 to the position of FIG. 4. In effect, the flange 11 presses on the roll 10 until the roll 10 slides counterclockwise until its outer periphery contacts inclined surface 14 of channel member 3, as seen in FIG. 4. At the same time, roll 9 contacts the inclined surface 13, which is then parallel to the axis X of roll 9, the surface 14 being then parallel to the axis Y of roll 10. The beams 8 thus swing downwardly in opposite directions away from each other about their respective pivots 17.

Roll 10 can be larger than roll 9, because roll 10 does not have to engage between flanges 11 and 12 except along its uppermost portions. Roll 9 is smaller, however, in order to fit between the flanges 11 and 12 and contact the flange 12 at the same time that roll 10 contacts flange 11.

The weight of the patient contributes to this engagement of the rolls 9 and 10 in the channel members 3. The heavier the patient, the more firmly will the rolls 9, 10 be pressed into contact with and between the converging surfaces 13 and 14 of channel members 3. In this way, it is ensured that the rolls 9, 10 will not jump their tracks.

To remove the table top from its supporting structure, it is necessary only to lift it straight up. The channel members 3 rise with the table top 1, from the position of FIG. 4 to the position of FIG. 5. In effect, flange 12 presses against roll 9 to swing the assembly 8-10 up and out of the way, the beams 8 in this case swinging upwardly and in opposite directions toward each other, until bottom flange 12 clears roll 9 and the table top is freely supported on transport carrier 2 for removal of the patient from the region of the X-ray equipment.

Thanks to the fact that the two roll pairs 9, 10 associated with each channel member 3 are supported in common on a rigid lateral beam 8, the table top can be loaded eccentrically, that is, in cantilever fashion. This is shown diagrammatically in FIG. 6 by the force P, which acts at an outer end of the table top in one of its extreme horizontal positions. Nevertheless, the roll pairs 9, 10 cannot leave their position of engagement as shown in FIG. 4.

In view of the foregoing disclosure, therefore, it will be evident that all of the initially recited objects of the present invention have been achieved.

Although the present invention has been described and illustrated in connection with a preferred embodiment, it is to be understood that modifications and variations may be resorted to without departing from the spirit of the invention, as those skilled in this art will readily understand. Such modifications and variations are considered to be within the scope of the present invention as defined by the appended claims.

Having described my invention, I claim:

1. An X-ray table comprising a support, a table top for supporting a patient, and means mounting the table top on the support for horizontal movement relative to the support, said means comprising a pair of spaced parallel channel members mounted on the under side of the table top and having generally horizontal flanges so that the channel members open horizontally, a plurality of rolls carried by said support and engageable in each of said channel members to support the table top rollably on said support, and means mounting the rolls for vertical swinging movement about horizontal axes transverse to and spaced below the axes of the rolls, said axes of vertical swinging movement of the rolls being spaced horizontally from the channel members in the direction in which the channel members open so that when the table top is placed on the rolls, the rolls will swing downwardly and move into the channel members, and when the table top is lifted, the rolls will swing upwardly and move out of the channel members.

2. An X-ray table as claimed in claim 1, the channel members opening toward each other and extending along opposite sides of the table.

3. An X-ray table as claimed in claim 1, and a first pair of elongated members on which said rolls are mounted, said first elongated members being parallel to said channel members, and a second pair of elongated members on which said first pair of elongated members are mounted for vertical swinging movement about horizontal axes, said first elongated members being parallel to each other, said second elongated members being parallel to each other and perpendicular to said first elongated members, said first and second elongated members being pivotally interconnected at their ends to form a rectangle.

4. An X-ray table as claimed in claim 3, and means mounting said second pair of elongated members for horizontal rolling movement parallel to their length.

5

5. An X-ray table as claimed in claim 1, said rolls being mounted in adjacent pairs each of which comprises a roll of relatively small size and a roll of relatively large size with the axes of the rolls of each pair disposed at an acute angle to each other, each said channel member having flanges whose confronting inner surfaces converge in the direction of the bottom of the channel member, the larger of said rolls supporting the upper of said converging surfaces and the smaller of said rolls riding on the lower of said converging surfaces.

10 250—58

6

References Cited

UNITED STATES PATENTS

3,222,518	12/1965	Nagel	-----	250—54
2,872,584	2/1959	Schiring et al.	-----	250—54

RALPH G. NILSON, Primary Examiner

C. CHURCH, Assistant Examiner

U.S. Cl. X.R.