

Aug. 10, 1943.

A. E. PELZ

2,326,558

SPRING CLIP

Filed March 9, 1943

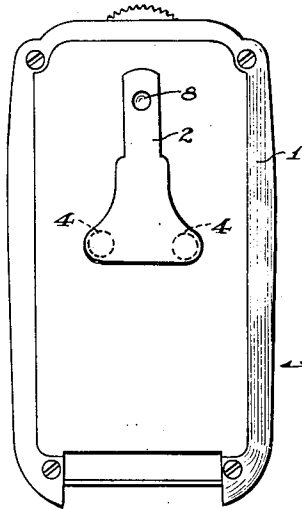

Fig. 1.

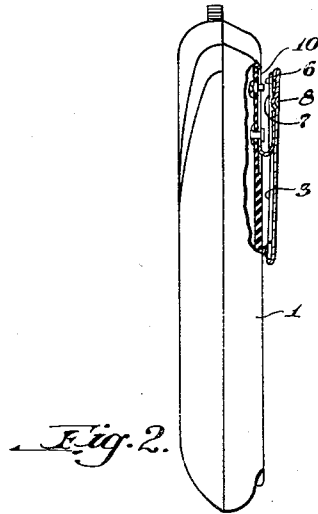

Fig. 2.

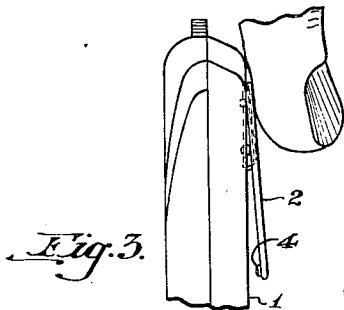

Fig. 3.

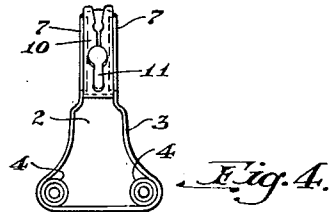

Fig. 4.

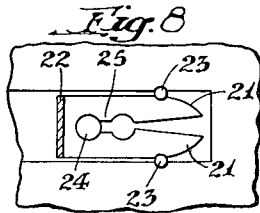

Fig. 8.

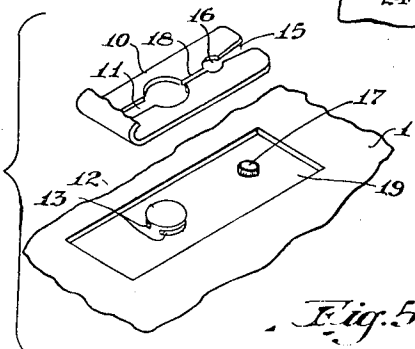

Fig. 5.

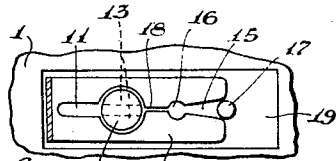

Fig. 6.

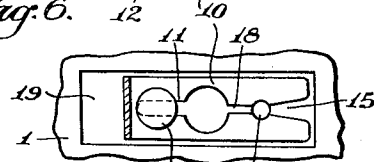

Fig. 7.

WITNESSES:
E. J. Maloney,
V. A. Beckham.

INVENTOR:
Alfred E. Pelz,
BY Brown, Critchlow & Flick
his ATTORNEYS.

UNITED STATES PATENT OFFICE

2,326,558

SPRING CLIP

Alfred E. Pelz, Mount Lebanon, Pa., assignor to
E. A. Myers & Sons, Pittsburgh, Pa., a partner-
ship consisting of Edward A. Myers, Edwin J.
Myers, and Samuel F. Lybarger

Application March 9, 1943, Serial No. 478,506

14 Claims. (Cl. 24-3)

This invention relates to hearing aid micro-
phone units, and more particularly to the clips
by which such units are attached to the gar-
ments of the wearers.

A hearing aid microphone unit customarily
has a clip attached to its case for holding it in
position in a pocket or in some other location
on the clothing of the user of the instrument.
Such clips often project a considerable distance
from the case and therefore add undesirably to
the thickness of the unit or press uncomfortably
against the wearer. It generally is desirable to
make the clips detachable so that the case can
be used without them, but those known hereto-
fore have had complicated connections or have
been difficult to remove and replace. They often
are attacked by perspiration which will corrode
the fine coil springs by which some of them are
operated.

It is among the objects of this invention to
provide a hearing aid microphone unit having
a clip that lies close to the case, which has little
tendency to catch on the clothing, which opens
wide, which is not injured by perspiration, which
is simple and inexpensive, which is rugged in
construction, and which is readily detachable
from the case.

In accordance with this invention, the upper
end of a clothing clip is spaced from the case of
a hearing aid microphone unit by a leaf spring
having spaced arms joined at one end by a resil-
ient portion. One of the arms is joined to the
clip and the other arm to the case. The spring
preferably is U-shape and detachably connected
to the case. For this purpose, means projects
from the case and overlies the case-engaging
arm of the spring to normally hold it against
the case, and this arm is slit down from its
upper end to provide laterally resilient fingers
that normally restrain the spring from vertical
movement on the case. However, under manual
pressure, the clip is movable vertically out of po-
sition so that it can be disengaged from the case.
Preferably, the lower end of the slot in the case-
engaging arm is in the form of a keyhole slot,
and a headed stud projects from the case
through the lower end of this slot to hold the
spring against the case. The laterally resilient
fingers are provided with side recesses for re-
ceiving means projecting from the case to nor-
mally hold the spring against movement down-
wardly thereon. The resiliency of the fingers
permits the spring to be manually slid down-
wardly on the case to move the enlarged portion
of the keyhole slot down to the stud so that the

clip and spring can be detached from the case.
The clip itself is preferably a straight piece of
metal the narrow upper end of which is con-
nected to the spring and the wide lower end of
which has two laterally spaced contact points
for engaging the clothing to which the clip is
fastened.

The invention is illustrated in the accompany-
ing drawing in which Fig. 1 is a back view of a
hearing aid case carrying my clip; Fig. 2 is a side
view thereof broken away on the center line to
show the clip assembly in section; Fig. 3 is a
fragmentary side view showing the clip pressed
open; Fig. 4 is a view of the inner side of the
clip; Fig. 5 is a fragmentary exploded perspec-
tive view of the spring and case; Fig. 6 is a frag-
mentary view showing the spring when first ap-
plied to the case; Fig. 7 is view like Fig. 6 but
showing the spring shifted into locked position;
and Fig. 8 is a view similar to Fig. 7 of a modifi-
cation.

Referring to the drawing, a hearing aid case
1 is shown which may contain a microphone and
suitable elements for amplifying the sound
picked up by the microphone. Attached to the
back of the case is a clip 2 for detachably fasten-
ing the case to the clothing of the person who
wears the hearing aid. This clip is made from
a thin flat piece of stainless steel or the like with
its edges 3 turned inwardly to strengthen it
and make it rigid. As shown in Figs. 1 and 4,
the upper half of the clip is straight and narrow
while the lower half is flared outwardly to form
a much wider lower end. Attached to the in-
ner face of this wide lower end at its opposite
sides are contact buttons 4 of any suitable mate-
rial, such as a resinous plastic that may be ce-
mented to roughened areas of the clip.

The upper end of the clip is spaced from the
case by a U-shape leaf spring that presses the
contact buttons against the case, as shown in
Fig. 2. The spring is made from a flat strip of
spring steel that is bent transversely to form two
arms connected at their lower ends by an integral
U-shape bend. One arm 6 is held tightly against
the inner face of the upper portion of the clip
by integral flanges 7 (Figs. 2 and 4) on the clip
which are bent inwardly over the sides of the
arm. The spring is prevented from moving longi-
tudinally of the clip by a detent 8 (Figs. 1 and 2)
pressed inwardly from the clip and projecting
into an aperture in the adjoining arm of the
spring.

To detachably connect the spring to the case,
the case-engaging arm 10 of the spring is pro-

vided near its lower end with a keyhole-shaped slot 11 having its enlarged circular opening at its upper end, as shown in Fig. 4. This opening is adapted to receive the head of a stud 12 that projects from the back of the case. The inner end of the stud may originally be hollow so that it can be riveted to the case. As shown in Fig. 5, the head is formed by providing the opposite sides of the cylindrical body of the stud with slots 13 which reduce its width transversely of the case only to permit the stud to enter the narrow portion of the slot when the clip is slid upwardly on the case. The head of the stud will thus overlie the arm of the spring on the opposite sides of the slot and thereby hold the spring against the case. The pressure of the lower end of the clip against the case presses the lower end of the spring against the stud head and thereby presses the upper end of the spring against the case.

In order to restrain the clip from being moved downwardly on the case, which would permit them to be separated, the upper end of the case-engaging arm of the spring has a downwardly extending notch 15 which is widened at its lower end to provide recesses 16 in the side walls of the notch, as shown in Figs. 4, 5, and 6. A pin 17, which is riveted to the case and projects therefrom into these recesses, as shown in Fig. 7, is wider than the portion of the notch directly above it so that in order to move the clip downwardly on the case, sufficient downward pressure must be applied to the clip to cause the pins to spread the sides of the notch apart so that the pin can pass out of it. The sides of the notch are in the form of laterally resilient fingers the resiliency of which is increased by providing the arm with a slit 18 that connects the notch and slot, whereby the entire arm is bifurcated. Pin 17 may be of large enough diameter to keep the fingers spread slightly when it is in recesses 16. If the pin is not made of a metal hard enough to prevent the spring from cutting into its sides, it may be encircled by a hard metal washer.

The spacing between the stud and pin is such that when the spring is first pressed back against the case with the stud in the upper end of slot 11, as shown in Fig. 6, pin 17 is at the entrance to notch 15. By merely pushing the clip upwardly, the spring will slide up the case with the stud entering the narrow end of the slot and with the sides of the notch spreading apart as they slide against the pin until the pin snaps into recesses 16 (Fig. 7) to hold the clip in place. The clip can be readily removed by pushing it downwardly until it can be pulled over the head of the stud. Due to the head of the stud being formed in the manner shown by slots 13, the head does not catch on the spring when the latter is moved down to the Fig. 6 position and interfere with removal of the spring from the case. It is preferred to provide the case with a rectangular depression 19 for the spring that serves the double purpose of a guide for the spring in attaching it to the case, and a recess for the arm 10 so that the spring and stud and pin will not project from the case any farther than necessary. Due to the use of a leaf spring and the two-point contact of the clip, the clip can cant sufficiently to compensate for unequal thickness of clothing and thus always grip the clothing at two laterally spaced points. Such a spring is strong and durable and very unlikely to be harmed by perspiration.

In the modification shown in Fig. 8, the laterally resilient fingers 21 of the case-engaging arm of the spring 22 are not engaged by a pin between

them, but rather by means projecting from the case at the opposite sides of the arm. Although the projecting means may be merely molded projections integral with the case, it is preferred to use a pair of metal pins 23 located at the opposite sides of the spring-receiving recess in the case. The sides of these pins normally extend into recesses in the opposite sides of the spring arm. When the clip is pushed downwardly on the case the resilient fingers are forced together slightly by the pins so that they can pass between them until the head of the stud 24 reaches the enlarged upper end of the slot 25. The clip can then be removed from the case in the manner described above.

According to the provisions of the patent statutes, I have explained the principle and construction of my invention and have illustrated and described what I now consider to represent its best embodiment. However, I desire to have it understood that, within the scope of the appended claims, the invention may be practiced otherwise than as specifically illustrated and described.

I claim:

1. A hearing aid microphone unit comprising a case, a clothing clip, a leaf spring spacing the upper end of the clip from the case and urging its lower end toward the case, said spring having spaced arms joined at one end by a resilient portion, one of said arms being joined to the clip and the other arm being joined to the case, said spring being the sole means for connecting the clip to the case.

2. A hearing aid microphone unit comprising a case, a clothing clip, a leaf spring spacing the upper end of the clip from the case and urging its lower end toward the case, said spring having spaced arms joined at one end by a resilient portion, one of said arms being joined to the clip and the other arm engaging the case, and means projecting from the case and overlying the case-engaging arm to normally hold the spring against the case, said arm being bifurcated to provide laterally resilient fingers that normally restrain the spring from vertical movement on the case, and said arm being manually movable vertically on the case to disengage it from said means.

3. A hearing aid microphone unit comprising a case, a clothing clip, a leaf spring spacing the upper end of the clip from the case and urging its lower end toward the case, said spring having spaced arms joined at one end by a resilient portion, one of said arms being joined to the clip and the other arm engaging the case, the case-engaging arm having a longitudinal slot near its lower end, a stud projecting from the case and through the lower end of the slot, and having a head normally overlying the arm to hold the spring against the case, the upper end of the slot being enlarged to pass said head, the upper end portion of said case-engaging arm being bifurcated to provide laterally resilient fingers, and means projecting from the case beside said fingers, said fingers being provided with side recesses for receiving said means to normally hold the spring against movement downwardly on the case, the lateral resiliency of the fingers permitting the spring to be manually slid downwardly on the case to move said enlarged portion of said slot to the stud, whereby said clip and spring can be detached from the case.

4. A hearing aid microphone unit comprising a case, a clothing clip, a leaf spring spacing the

upper end of the clip from the case and urging its lower end toward the case, said spring having spaced arms joined at one end by a resilient portion, one of said arms being joined to the clip and the other arm engaging the case, the case-engaging arm having a longitudinal slot near its lower end, a stud projecting from the case and through the lower end of the slot and having a head normally overlying the arm to hold the spring against the case, the upper end of the slot being enlarged to pass said head, said case-engaging arm also having a notch extending downwardly from its upper end, and a pin projecting from the case and into the lower end of the notch, the width of said notch being restricted directly above the pin to normally hold the spring against movement downwardly on the case, and the sides of the notch being resiliently spreadable to permit the restricted portion of the notch to pass the pin when the spring is manually slid downwardly on the case to move said enlarged portion of said slot to the stud, whereby said clip and spring can be detached from the case.

5. A hearing aid microphone unit comprising a case, a clothing clip having its lower end normally engaging the case, a U-shape leaf spring having spaced arms engaging the clip and case and joined at their lower ends by a resilient bent portion, the clip-engaging arm being attached to the clip, the case-engaging arm having a longitudinal slot near its lower end, a stud projecting from the case and through the lower end of the slot and having a head normally overlying the arm to hold the spring against the case, the upper end of the slot being enlarged to pass said head, the upper end portion of said case-engaging arm being bifurcated to provide laterally resilient fingers, and means projecting from the case beside said fingers, said fingers being provided with side recesses for receiving said means to normally hold the spring against movement downwardly on the case, the lateral resiliency of the fingers permitting the spring to be manually slid downwardly on the case to move said enlarged portion of said slot to the stud, whereby said clip and spring can be detached from the case.

6. A hearing aid microphone unit comprising a case, a clothing clip, a leaf spring spacing the upper end of the clip from the case and urging its lower end toward the case, said spring having spaced arms joined at one end by a resilient portion, one of said arms being joined to the clip and the other arm engaging the case, the case being provided with an arm-receiving depression having a depth at least as great as the thickness of the adjoining arm, and means projecting from the case and overlying the case-engaging arm to normally hold the spring against the case, said arm being bifurcated to provide laterally resilient fingers that normally restrain the spring from vertical movement on the case, and said arm being manually movable vertically on the case to disengage it from said means.

7. A hearing aid microphone unit comprising a case, a clothing clip, a leaf spring spacing the upper end of the clip from the case and urging its lower end toward the case, said spring having spaced arms joined at one end by a resilient portion, one of said arms engaging the clip and having a recess in it, a portion of the clip overlying the arm to hold it against the clip, the clip having a detent projecting into said recess to hold the spring against longitudinal movement rela-

tive to the clip, and means connecting the other arm of the spring to the case.

8. A hearing aid microphone unit comprising a case, a clothing clip, a leaf spring spacing the upper end of the clip from the case and urging its lower end toward the case, said spring having spaced arms joined at one end by a resilient portion, one of said arms being joined to the clip and the other arm engaging the case, the case-engaging arm having a longitudinal slot near its lower end, a stud projecting from the case and through the lower end of the slot and having a head normally overlying the arm to hold the spring against the case, the upper end of the slot being enlarged to pass said head, said case-engaging arm also having a notch extending downwardly from its upper end, the portion of said arm between said notch and slot being split longitudinally, and a pin projecting from the case and into the lower end of the notch, the width of said notch being restricted directly above the pin to normally hold the spring against movement downwardly on the case, and the sides of the notch being resiliently spreadable to permit the restricted portion of the notch to pass the pin when the spring is manually slid downwardly on the case to move said enlarged portion of said slot to the stud, whereby said clip and spring can be detached from the case.

9. A hearing aid microphone unit comprising a case, a clothing clip having laterally spaced case-engaging points, a leaf spring spacing the upper end of the clip from the case and urging its lower end toward the case, said spring having spaced arms joined at one end by a resilient portion, one of said arms being joined to the clip and the other arm being joined to the case.

10. A hearing aid microphone unit comprising a case, a clothing clip, a leaf spring spacing the upper end of the clip from the case and urging its lower end toward the case, said spring having spaced arms joined at one end by a resilient portion, one of said arms being joined to the clip and the other arm engaging the case, the case-engaging arm having a longitudinal slot near its lower end, a stud projecting from the case and through the lower end of the slot and having a head normally overlying the arm to hold the spring against the case, the upper end of the slot being enlarged to pass said head, said arm being bifurcated to provide laterally resilient fingers that normally restrain vertical movement of the spring on the case, and said arm being manually movable downwardly on the case to move said enlarged portion of the slot to the stud, whereby said clip and spring can be detached from the case.

11. A hearing aid microphone unit comprising a case, a clothing clip, a leaf spring spacing the upper end of the clip from the case and urging its lower end toward the case, said spring having spaced arms joined at one end by a resilient portion, one of said arms being joined to the clip and the other arm engaging the case, means projecting from the case and overlying the case-engaging arm to normally hold the spring against the case, the upper end portion of said arm being bifurcated to provide laterally resilient fingers, and means projecting from the case beside said fingers, said fingers being provided with side recesses for receiving said means to normally hold the spring against downward movement on the case, the lateral resiliency of the fingers permitting the spring to be manually slid downwardly on the case to disengage it from said means.

12. A hearing aid microphone unit comprising a case, a clothing clip, a leaf spring spacing the upper end of the clip from the case and urging its lower end toward the case, said spring having spaced arms joined at one end by a resilient portion, one of said arms being joined to the clip and the other arm engaging the case, the case-engaging arm having a longitudinal slot near its lower end, a stud projecting from the case and through the lower end of the slot, said stud having slots in its opposite sides for receiving the spring and to thereby form a head overlying the arm, the upper end of the slot being enlarged to pass said head, said arm being bifurcated to provide laterally resilient fingers that normally restrain vertical movement of the spring on the case, and said arm being manually movable downwardly on the case to move said enlarged portion of the slot to the stud, whereby said clip and spring can be detached from the case.

13. A hearing aid microphone unit comprising a case, a clothing clip, a leaf spring spacing the upper end of the clip from the case and urging its lower end toward the case, said spring having spaced arms joined at one end by a resilient portion, one of said arms being joined to the clip and the other arm engaging the case, means projecting from the case and overlying the case-engaging arm to normally hold the spring against the

case, the upper end portion of said arm being bifurcated to provide laterally resilient fingers having recesses in their outer edges, and means projecting from the case and into said recesses to normally hold the spring against downward movement on the case, the lateral resiliency of the fingers permitting the spring to be manually slid downwardly on the case between said last-mentioned to disengage it from the case.

14. A hearing aid microphone unit comprising a case, a clothing clip, a leaf spring spacing the upper end of the clip from the case and urging its lower end toward the case, said spring having spaced arms joined at one end by a resilient portion, one of said arms being joined to the clip and the other arm engaging the case, means projecting from the case and overlying the case-engaging arm to normally hold the spring against the case, the upper end portion of said arm being bifurcated to provide laterally resilient fingers having recesses in their outer edges, and a pair of pins projecting from the case and into said recesses to normally hold the spring against downward movement on the case, the lateral resiliency of the fingers permitting the spring to be manually slid downwardly between said pins to disengage it from the case.

ALFRED E. PELZ.