



(12) **EUROPEAN PATENT APPLICATION**

(43) Date of publication:
28.04.2021 Bulletin 2021/17

(51) Int Cl.:
B65D 5/20 (2006.01) B65D 5/42 (2006.01)

(21) Application number: **20202858.5**

(22) Date of filing: **20.10.2020**

(84) Designated Contracting States:
AL AT BE BG CH CY CZ DE DK EE ES FI FR GB GR HR HU IE IS IT LI LT LU LV MC MK MT NL NO PL PT RO RS SE SI SK SM TR
 Designated Extension States:
BA ME
 Designated Validation States:
KH MA MD TN

(72) Inventors:
 • **DOMINGUES, Tiago Nuno**
2400-148 Leiria (PT)
 • **PIRES, Antonio**
6300-127 Macainhas-Guarda (PT)
 (74) Representative: **Gerbino, Angelo et al**
Jacobacci & Partners S.p.A.
Corso Emilia 8
10152 Torino (IT)

(30) Priority: **21.10.2019 ES 201931718 U**

(71) Applicant: **Nova DS Smith Embalagem SA**
4487-255 Guilhabreu (PT)

(54) **CARDBOARD CONTAINER WITH INTEGRATED LID**

(57) The cardboard container has an integral lid and is obtained from a cardboard sheet duly die-cut in a single piece in which a central sector or bottom (1) is defined, from whose edges two respective isoscelic inverted trapezoidal sectors emerge that determine the larger (2) and smaller (3) side walls of the container. Two of these walls are provided in correspondence to their lateral edges with

tabs (4) for gluing together the adjoining walls. From one of the side walls there emerges a sector that acts as a lid (5), with a configuration in accordance with the configuration of the bottom (1) but with proportionally larger dimensions, which ends in opposition to its fold line (6) in a tab (7) for closing and stabilizing the lid (5).

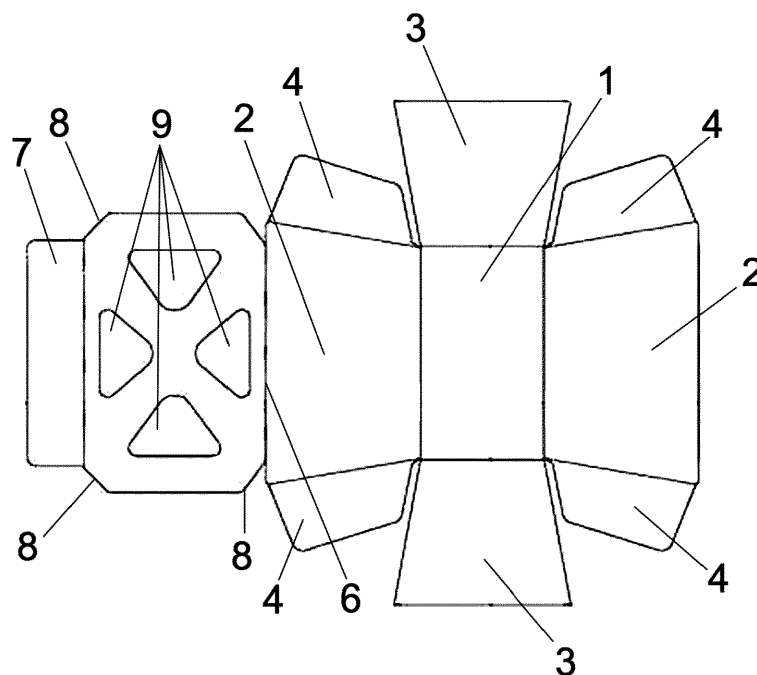

FIG. 1

Description

FIELD OF THE INVENTION

[0001] The present invention relates to a cardboard container or box obtained from a single piece, specifically from a die-cut cardboard sheet, with such piece including sectors so as to form both the body of the box and a folding lid.

[0002] The object of the invention is to provide a cardboard container with a special configuration that allows it to be assembled in an industrialized and automated manner, enabling the containers to be stacked with their lid open, occupying minimal volumetric space.

[0003] The invention is applicable to multiple areas, as it is perfectly scalable, although its preferred area is the storage and transport of fruit and vegetable products, in order to replace the classic plastic packages, while not ruling out storage and transport of further types of products.

BACKGROUND OF THE INVENTION

[0004] In the field of practical application of the invention, that of fruit and vegetable products, when transporting and marketing these kinds of products, transparent plastic packages obtained by moulding a single piece are used, which include a folding lid, as well as windows for aeration of the product contained within it.

[0005] Obviously, the use of this type of material is a problem from an environmental viewpoint, which can be perfectly remedied by the container of the invention.

[0006] In this sense, although there are already cardboard packages with a lid obtained from a single piece of die-cut cardboard, this type of package can be stacked one on top of the other with the lid closed, occupying a large volume of space.

[0007] However, there are no known cardboard packages with a folding lid structured such that they can be stacked with their lids open after the package has been assembled, with one partially inserted into the other, such that their volumetric occupation in the stack is minimal.

SUMMARY OF THE INVENTION

[0008] The cardboard container with integrated lid herein disclosed solves, in a fully satisfactory manner, the above mentioned problems, based on a simple but effective solution.

[0009] For this, the container of the invention is obtained from a cardboard sheet, either simple or composite, duly die-cut in a single piece, in which die-cutting process a rectangular or quadrangular central sector is defined, from each edge of which an inverted isosceles trapezoidal sector emerges that will determine the side walls of the package, with two such walls provided in correspondence to their side edges with two tabs for gluing and assembling the container, which then forms a

kind of inverted truncated conical prism that, as will be seen later, will facilitate stacking operations by minimizing the use of space.

[0010] One of said side walls, preferably one with the larger side walls, extends upward into a closing lid that, in opposition to the edge that determines the folding zone of the lid, is capped off with a tab that closes by plugging into the inner edge of the larger opposite side wall, when the container is closed.

[0011] The main or determining sector of the lid, set up in the same way as the bottom, but larger, will present bevelled corners, in order to define aeration gaps to maximize the useful life of the products contained within the container, preferably fruit and vegetable products.

[0012] In this sense, it has also been envisaged that said determining sector of the cover includes a series of triangular windows, also determining ventilation/aeration holes for the same purpose as the aforementioned bevelled corners.

[0013] The special structure of the container means that it can be assembled mechanically through conventional machinery, gluing the tabs of the larger side walls to the inner edges of the smaller side walls, leaving the lid in the vertical position in the assembly. The resulting inverted truncated pyramid configuration of the container allows the containers to be stacked very easily, practically automatically, by self-centring by their own weight, leaving the containers partially inserted into each other, which optimizes the available space.

BRIEF DESCRIPTION OF THE DRAWINGS

[0014] To complete the description that will soon be made, and in order to aid a better understanding of the characteristics of the invention according to an example of a preferred embodiment thereof, a set of drawings are provided that form an integral part of this description where, for purposes of illustration and in a non-limiting sense, the following is shown:

Figure 1.- Shows a top plan view of a cardboard sheet from which a container with an integrated lid is obtained in accordance with the object of the present invention.

Figure 2.- Shows a view similar to that of figure 1, but for a variant in which the height of the container is lower.

Figure 3.- Shows a perspective view of the container properly assembled from the cardboard sheet of figure 1 and with its lid closed.

Figure 4.- Finally, shows a perspective view of various stacked containers with their lids open, partially inserted into each other, occupying a minimum volume of space.

PREFERRED EMBODIMENT OF THE INVENTION

[0015] In view of the figures outlined, it can be seen how the cardboard container with an integrated lid of the invention is obtained from a cardboard sheet that, as mentioned previously, can be simple or composite, and can even include anti-humidity coatings or coatings of any other type common in the sector, a sheet duly die-cut in a single piece and in which a central sector or bottom (1) is defined, which, in the chosen examples, presents a rectangular configuration, tending towards the square in the variant shown in figure 2, and which could also be square, from whose edges there emerge respective inverted isoscelic trapezoidal sectors, which will determine the larger (2) and smaller (3) side walls of the container, with there being two of these walls, in the chosen examples the larger side walls (2), provided with two trapezoidal tabs (4) corresponding to their lateral edges for gluing and assembling the container.

[0016] One of the larger side walls (2) is capped off in opposition to its folding edge over the bottom (1) in a lid (5), in the rectangular embodiments, tending towards a square in the variant shown in Figure 2, with proportionally larger dimensions than said bottom (1), wherein the lid (5) is foldable through a folding line (6), in opposition to which a stabilizing tab (7) of the lid is established in the closed situation.

[0017] Said tab (7) will preferably have a horizontally elongated rectangular configuration.

[0018] Figure 3 shows the container of the invention duly assembled and with its lid (5) closed, and it can be observed how the tab (7) stably retains said lid (5) against the larger side wall (2), also showing the inverted truncated pyramid-shaped configuration of the container which, as seen in figure 4, significantly facilitates the stacking manoeuvres of the boxes or containers with their lid (5) open, presenting a minimal volumetric occupation.

[0019] The determining or main sector of the lid (5) will present bevels (8) at its corners, in order to define aeration gaps in the closure of the lid on the main body of the container, in order to maximize the useful life of the products contained within, for which said determining sector of the cover (5) will be perforated by various triangular windows (9), also determining ventilation/aeration holes with the same purpose as the aforementioned bevelled corners.

[0020] As has been previously mentioned, the trapezoidal configuration of the internal gluing tabs (4) is specially designed to be compatible with standard assembly machines and their glue injection system.

[0021] In this way, an economical, effective, easily stackable container is achieved with minimal volumetric occupation, and it is totally ecological.

Claims

1. Cardboard container with an integrated lid, **characterized**

by being obtained from a cardboard sheet duly die-cut in a single piece in which a central sector or bottom (1), rectangular or quadrangular, is defined, from whose edges respective isoscelic inverted trapezoidal sectors emerge that determine the larger (2) and smaller (3) side walls of the container, which has two of these walls provided in correspondence to their lateral edges with tabs (4) for gluing together the adjoining walls, with the particularity that from one of said side walls there emerges a sector that functions as a lid (5), with a configuration in accordance with the configuration of the bottom (1) but with proportionally larger dimensions, which ends in opposition to its fold line (6) in a tab (7) for closing and stabilizing the lid (5).

2. Cardboard container with integrated lid, according to claim 1, **characterized in that** the tabs (4) emerge laterally from the larger side walls (2).

3. Cardboard container with an integrated lid, according to claim 1 or 2, **characterized in that** the lid (5) emerges upwards from one of the larger side walls (2).

4. Cardboard container with an integrated lid, according to claim 1, 2 or 3, **characterized in that** the determining sector of the lid (5) has bevels (8) at its corners that, when closing the lid on the main body of the container, determine ventilation holes for the products contained within it.

5. Cardboard container with an integrated lid, according to claim 1, 2, 3 or 4, **characterized in that** the determining sector of the lid (5) has windows (9) which determine the ventilation holes of the products contained therein.

6. Cardboard container with an integrated lid, according to claim 5, **characterized in that** the windows (9) are triangular in configuration.

7. Cardboard container with an integrated lid, according to any one of the preceding claims, **characterized in that** the tab (7) of the lid (5) has a horizontally elongated rectangular configuration.

8. Cardboard container with an integrated lid, according to any one of the preceding claims, **characterized in that** the cardboard sheet from which the container is obtained is simple cardboard.

9. Cardboard container with an integrated lid, according to any one of the preceding claims 1 to 7, **characterized in that** the cardboard sheet from which the container is obtained is made of composite cardboard.

10. Cardboard container with an integrated lid, according to any one of the preceding claims, **characterized in that** the cardboard sheet from which the container is obtained includes a coating of anti-humidity material.

5

10

15

20

25

30

35

40

45

50

55

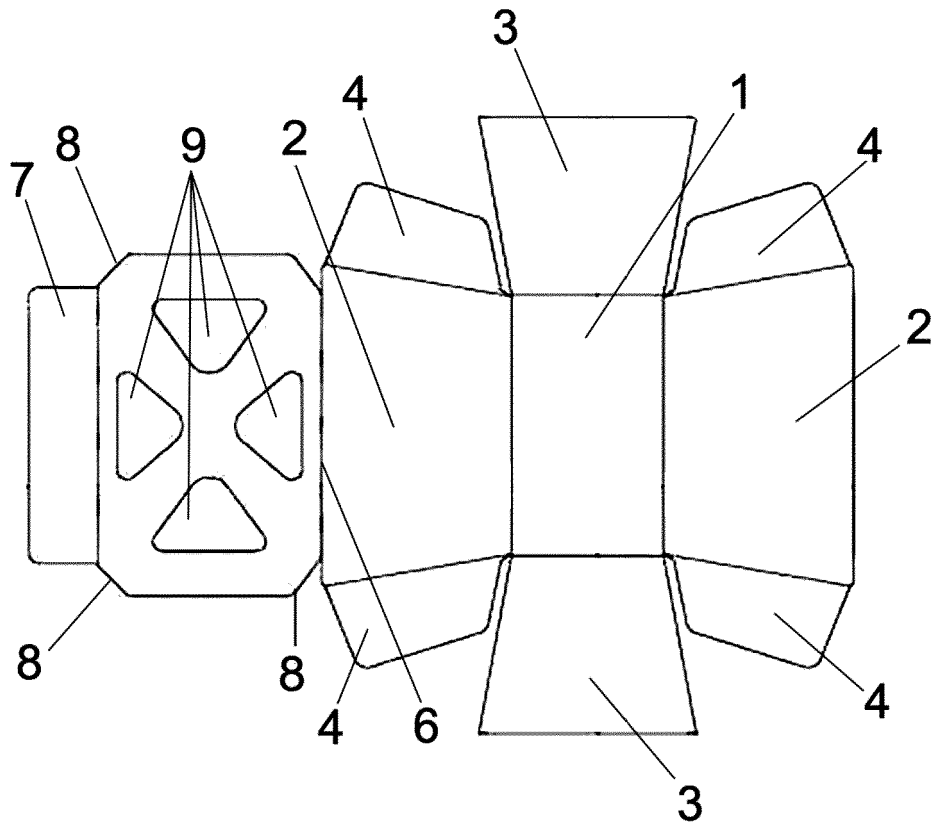

FIG. 1

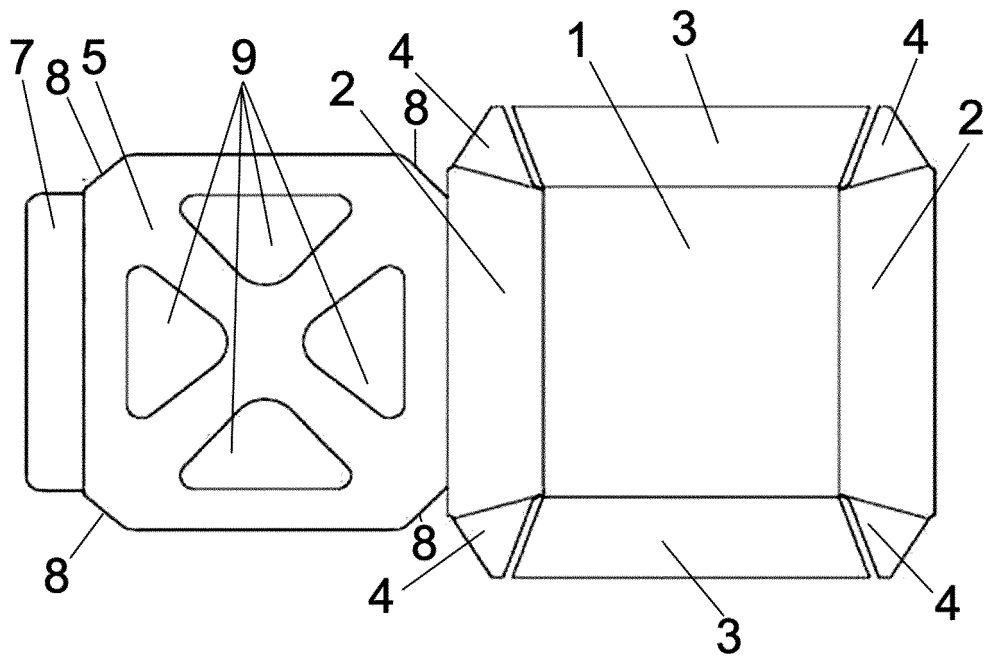

FIG. 2

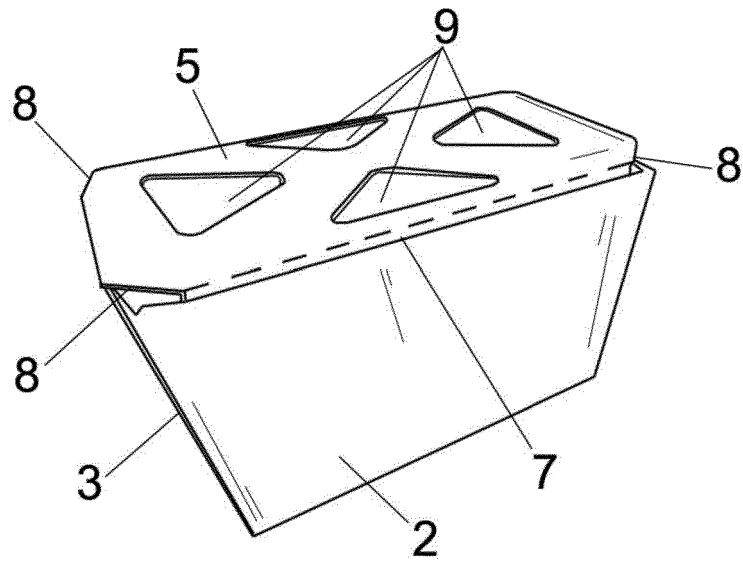

FIG. 3

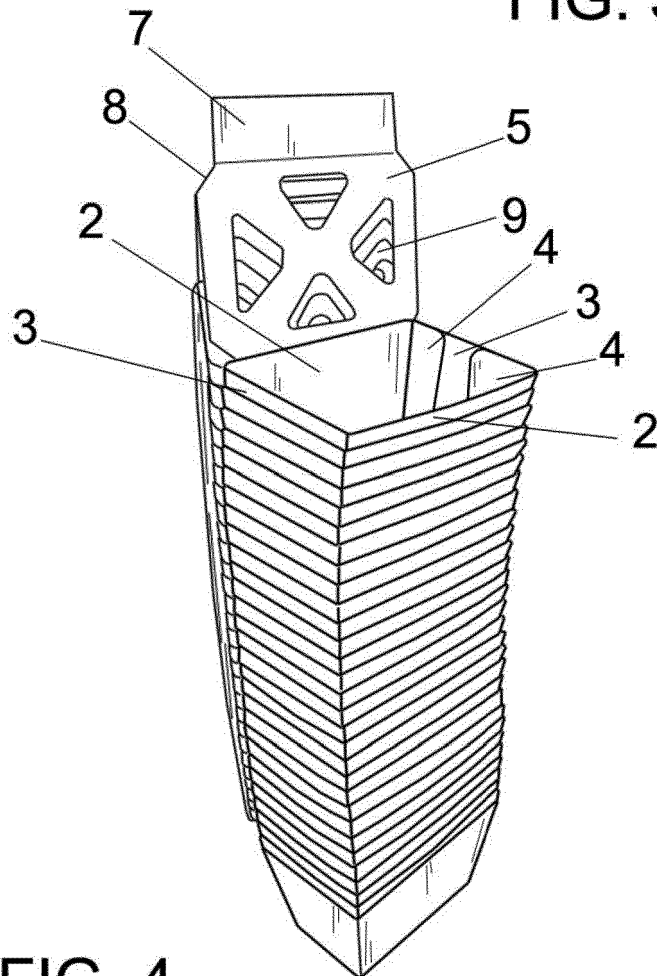

FIG. 4



EUROPEAN SEARCH REPORT

Application Number
EP 20 20 2858

5

10

15

20

25

30

35

40

45

50

55

DOCUMENTS CONSIDERED TO BE RELEVANT			
Category	Citation of document with indication, where appropriate, of relevant passages	Relevant to claim	CLASSIFICATION OF THE APPLICATION (IPC)
X	EP 0 026 430 A1 (UNILEVER NV [NL]; UNILEVER PLC [GB]) 8 April 1981 (1981-04-08)	1-3,7,8	INV. B65D5/20 B65D5/42
Y	* figure 2 *	4-6,9,10	
Y	FR 1 396 014 A (M. JEAN FODOT) 16 April 1965 (1965-04-16) * page 1, column 2, lines 24-40; figure 1 *	4	
Y	US 2 134 051 A (KIRBY JOHN S) 25 October 1938 (1938-10-25) * figure 1 *	5,6	
Y	US 2019/241305 A1 (RODRIGUEZ FRANCISCO [CR]) 8 August 2019 (2019-08-08) * figure 5 *	5,6	
Y	GB 2 328 679 A (BPB PLC [GB]) 3 March 1999 (1999-03-03) * page 5, lines 21-24 *	9	
Y	US 4 631 046 A (KENNEDY KENNETH V [US]) 23 December 1986 (1986-12-23) * page 1, lines 10-15 *	10	
A	US 5 921 466 A (SPEESE SCOTT [US] ET AL) 13 July 1999 (1999-07-13) * figures 1-10 *	1-10	
A	CH 523 177 A (KLAESI NUXO WERK AG J [CH]) 31 May 1972 (1972-05-31) * figures 1-4 *	1-10	
The present search report has been drawn up for all claims			
Place of search Munich		Date of completion of the search 4 March 2021	Examiner Jervelund, Niels
CATEGORY OF CITED DOCUMENTS X : particularly relevant if taken alone Y : particularly relevant if combined with another document of the same category A : technological background O : non-written disclosure P : intermediate document T : theory or principle underlying the invention E : earlier patent document, but published on, or after the filing date D : document cited in the application L : document cited for other reasons & : member of the same patent family, corresponding document			

EPO FORM 1503 03.82 (P04C01)

ANNEX TO THE EUROPEAN SEARCH REPORT
ON EUROPEAN PATENT APPLICATION NO.

EP 20 20 2858

5 This annex lists the patent family members relating to the patent documents cited in the above-mentioned European search report.
The members are as contained in the European Patent Office EDP file on
The European Patent Office is in no way liable for these particulars which are merely given for the purpose of information.

04-03-2021

Patent document cited in search report	Publication date	Patent family member(s)	Publication date
EP 0026430 A1	08-04-1981	DK 414880 A EP 0026430 A1 NL 7907304 A	03-04-1981 08-04-1981 06-04-1981
FR 1396014 A	16-04-1965	NONE	
US 2134051 A	25-10-1938	NONE	
US 2019241305 A1	08-08-2019	EP 3746368 A1 US 2019241305 A1 WO 2019152756 A1	09-12-2020 08-08-2019 08-08-2019
GB 2328679 A	03-03-1999	FR 2767786 A1 GB 2328679 A	05-03-1999 03-03-1999
US 4631046 A	23-12-1986	NONE	
US 5921466 A	13-07-1999	CA 2271491 A1 US 5921466 A	13-05-2000 13-07-1999
CH 523177 A	31-05-1972	NONE	

EPO FORM P0459

For more details about this annex : see Official Journal of the European Patent Office, No. 12/82