

J. A. HUMM.  
 DEVICE FOR CLEANING LAWNS AND STREETS.  
 APPLICATION FILED MAY 5, 1910.

998,517.

Patented July 18, 1911.

3 SHEETS—SHEET 1.

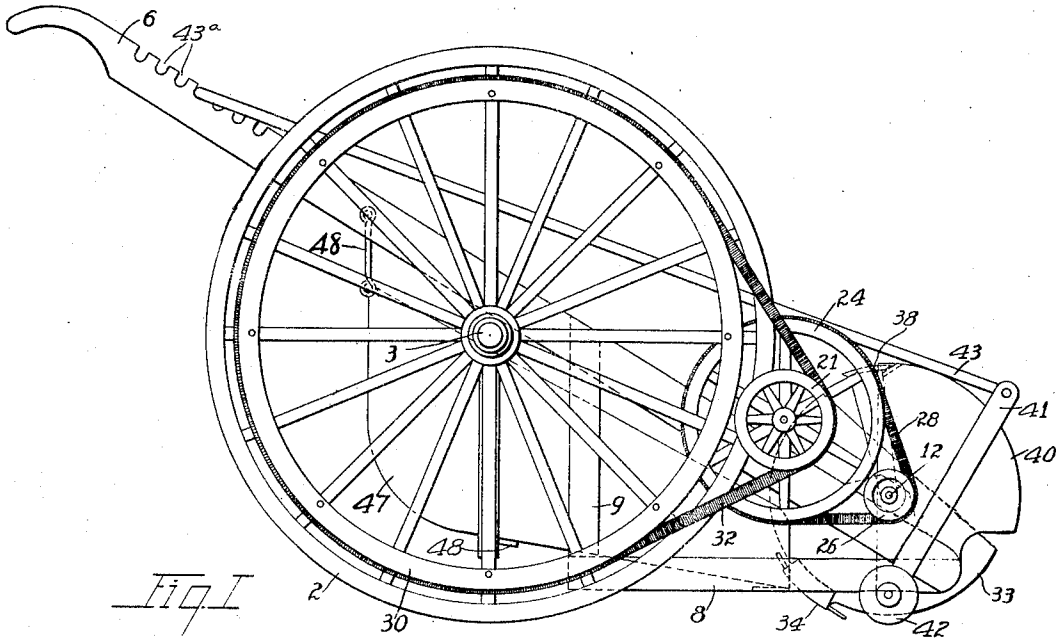

Fig. 1

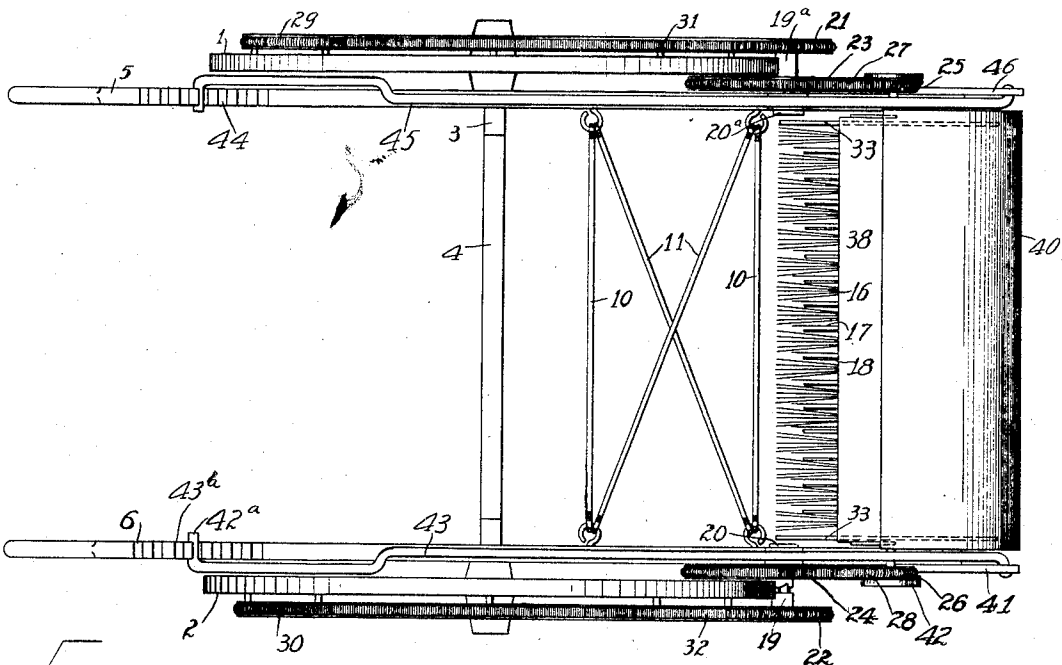

Fig. 2

Witnesses  
 Elmer A. Caspell  
 Barrman & West.

Inventor  
 Joseph A. Humm  
 By Bates, Tainto & Hull  
 Attys.

J. A. HUMM.  
 DEVICE FOR CLEANING LAWNS AND STREETS.  
 APPLICATION FILED MAY 6, 1910.

998,517.

Patented July 18, 1911.  
 3 SHEETS—SHEET 2.

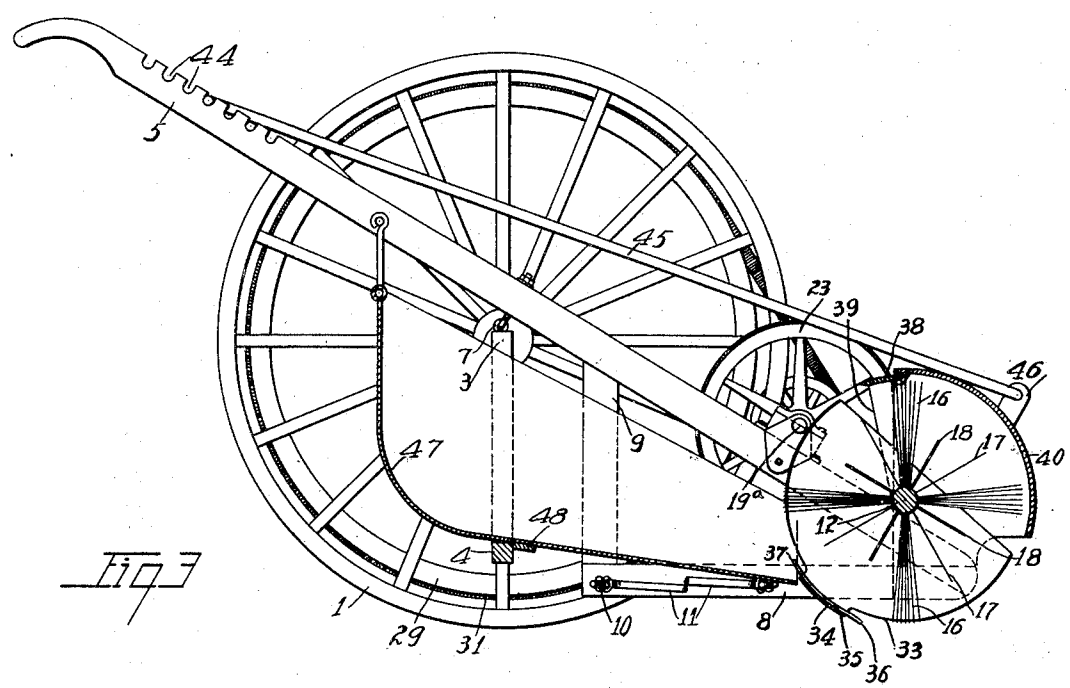

Fig. 3

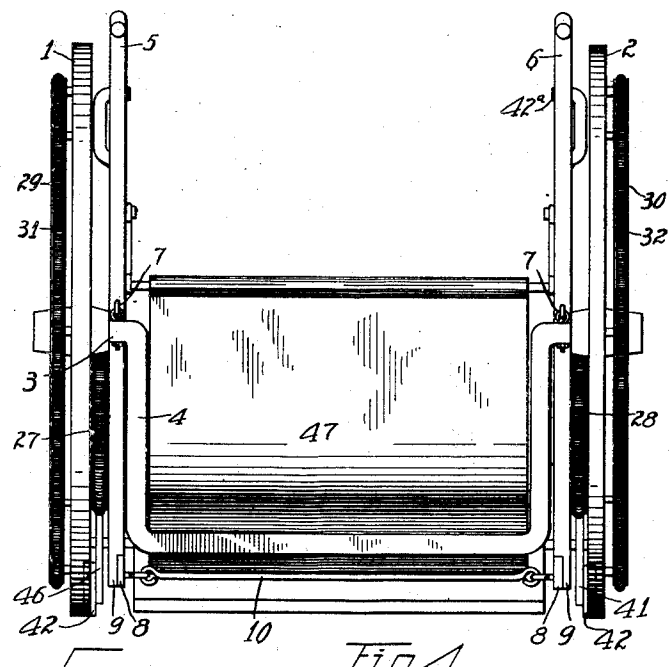

Fig. 4

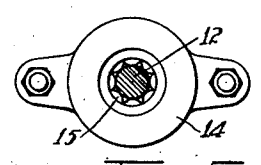

Fig. 5

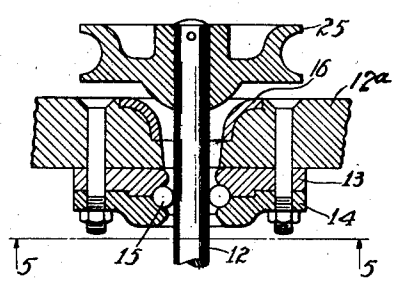

Fig. 6

Witnesses:  
 Elmer R. Caspell.  
 Foreman West.

Inventor:  
 Joseph A. Humm  
 By Bates T. Outts & Hull  
 Attys.

J. A. HUMM.  
 DEVICE FOR CLEANING LAWNS AND STREETS.  
 APPLICATION FILED MAY 5, 1910.

998,517.

Patented July 18, 1911.

3 SHEETS—SHEET 3.

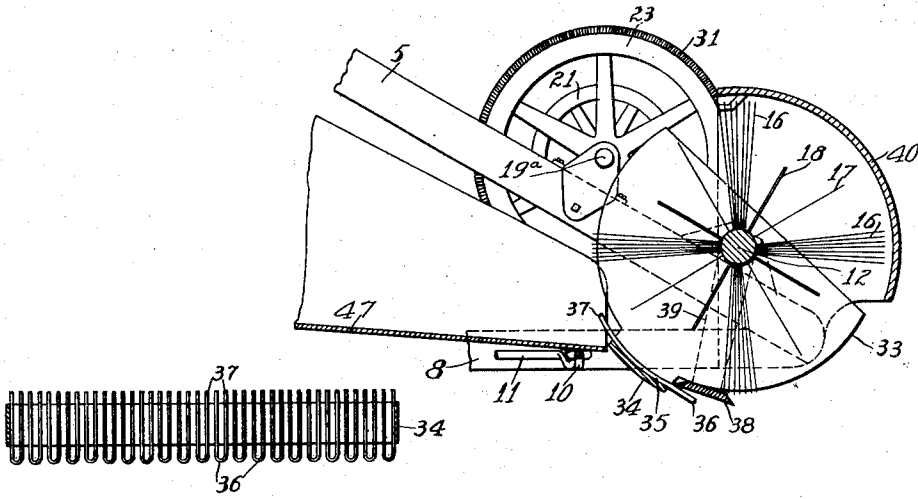

Fig. 9

Fig. 7

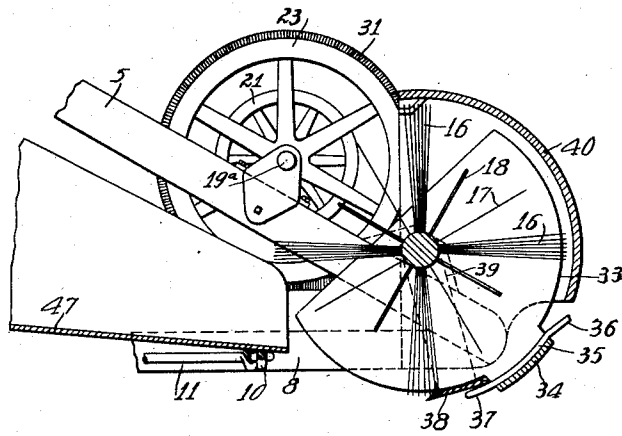

Fig. 8

Witnesses  
 Elmer A. Caspell  
 Foreman B. West.

INVENTOR.  
 Joseph A. Humm  
 By Bates, Torrey & Skell  
 Attys.

# UNITED STATES PATENT OFFICE.

JOSEPH A. HUMM, OF ELYRIA, OHIO.

DEVICE FOR CLEANING LAWNS AND STREETS.

998,517.

Specification of Letters Patent.

Patented July 18, 1911.

Application filed May 5, 1910. Serial No. 559,517.

*To all whom it may concern:*

Be it known that I, JOSEPH A. HUMM, a citizen of the United States, residing at Elyria, in the county of Lorain and State of Ohio, have invented a certain new and useful Improvement in Devices for Cleaning Lawns and Streets, of which the following is a full, clear, and exact description, reference being had to the accompanying drawings.

My invention relates to a device for cleaning lawns and streets, and provides a cleaning device wherein a rotary cleaner sweeps or brushes the material to be removed and causes it to lodge in a holding receptacle.

More especially, my invention embodies or provides a rotary brush the opposite ends of which may be independently adjusted when such is desired.

Generally speaking, the invention comprises the elements and combinations thereof set forth in the accompanying claims.

Reference should be had to the accompanying drawings forming a part of this specification in which the Figure 1 is a side elevation of the cleaning device; Fig. 2 is a top plan view with the holding receptacle removed; Fig. 3 is a central longitudinal section; Fig. 4 is a rear elevation; Fig. 5 is a section on the line 5—5 of Fig. 6; Fig. 6 is a longitudinal section through one of the bearing boxes for one of the shafts; Figs. 7 and 8 are central sections of portions of the device showing the manner in which the rods and scraper cooperate with the deflector; and Fig. 9 is a top plan view showing the rake.

In the embodiment of my invention, shown in the drawings, the cleaning device assumes the form of a cart or frame with wheels thereon which frame may be pushed or pulled as desired for the purpose of causing the brush to rotate and to remove material from the surface being operated upon. At 1 and 2 are two wheels which are mounted upon an axle 3 having a drop portion 4. The drop portion 4 extends nearly to the surface upon which the wheels rest. Side pieces 5 and 6 are mounted upon said axle by means of cooperating eye bolts 7 as will be clearly seen in Figs. 3 and 4. The members 5 and 6 are formed at their upper ends with handles shaped so as to be conveniently grasped by the operator.

Cooperating with the lower forward end of each side member is a horizontally dis-

posed member 8 which extends backward toward the axle and is secured to the side member by means of a connecting portion 9. These members 8 and 9, as shown in Fig. 1, are rigidly fastened upon the side member 6, but it will be understood that similar members are secured upon the side member 5.

Connecting the lower members 8 are rods or links 10 which extend straight across from side member to side member and are secured to the side members by means of cooperating eye bolts, as will be clearly seen in Fig. 2. The members 8 are also joined by additional diagonal members 11, also shown in Fig. 2. It will, therefore, be seen that the members 5 and 6 while joined together are flexibly joined and, furthermore, it will be apparent that the members 5 and 6 are also flexibly connected with the axle 3.

At the lower forward part, a brush shaft 12 is journaled near its opposite ends upon the side members 5 and 6. The manner in which the shaft 12 is journaled will be apparent from an inspection of Fig. 6. The shaft 12 extends through an opening in the bearing block 12<sup>a</sup> which is mounted upon member 5 and is held in central position in the opening by means of a ball bearing, one member 13 of which is secured against the member 5, and a cap 14 cooperates with the member 13. Between the two is a race-way in which balls 15 are placed, which balls encircle the shaft as shown in Fig. 5. An annular wear member 12<sup>b</sup> having a rounding surface is secured in the bearing 12<sup>a</sup> so that the pulley, which is upon the end of the shaft, will not wear the bearing block which is usually constructed of wood. The shaft at its opposite end is mounted upon the member 6 in a manner similar to that just described. It will, therefore, be apparent that the opposite front ends of the frame may be moved some distance without displacing or twisting the shaft 12.

Upon the shaft 12 is mounted the rotary sweeping element or brush which as shown consists of a series of brushing members 16 which are composed of bunches of metallic strips. These members 16 are located upon the shaft at right angles with respect to each other and extend the length of the shaft which is between the members 5 and 6. Between the members 16 are rows of projecting wires 17 which are somewhat shorter than the members 16 and of heavier material.

Another series of projecting wires 18 are also located upon the shaft 12, these members being shorter than the wires 17 and of still heavier wire. The purpose of this construction is that the brush may handle all material with which it comes in contact. The lighter material will be swept by the brushes 16 but if there be material which is too heavy for them the brushes will bend and the obstacle to be moved will be encountered either by the wires 17 or the wires 18, and it has been found in practice that the wires 18 are sufficiently strong to move an ordinary brick. With such a sweeping member, a surface such as a street or lawn may be easily and thoroughly cleaned.

Two stub shafts 19 and 19<sup>a</sup> are mounted in line with each other upon members 5 and 6 and the shafts are secured in journal boxes 20 and 20<sup>a</sup>. Upon the ends of the shafts 19 and 19<sup>a</sup> are pulleys 21 and 22 which are secured to the shafts. A pulley 23 is secured upon the shaft 19<sup>a</sup> adjacent the member 5 and a similar pulley 24 is mounted upon the shaft 19 adjacent the member 6. These pulleys 24 and 23 are free to rotate upon their shafts. A clutch connects the pulleys 22 and 24 in such a manner that when the cleaning device is pushed forward the pulleys 22 and 24 will be connected together, while if the wheel be caused to rotate in the opposite direction, the pulleys 22 and 24 will be disengaged from their driving relation. Such a form of clutch as here indicated being old in the art, I will not describe the same with great particularity as it specifically forms no part of my invention. Its use is merely to permit the cart to turn a corner with ease and without any dislocation of the parts of the device.

The opposite ends of the brush shaft 12 are provided with pulleys 25 and 26. These pulleys are operatively connected with the pulleys 23 and 24 by means of flexible driving members 27 and 28.

Upon each of the wheels 1 and 2 is secured an annular member 29 and 30 which annular members are of less diameter than the diameter of the wheel. The members 21 and 29, as well as the members 22 and 30, are operatively connected together by means of flexible driving members 31 and 32. It will, therefore, be apparent that when the cart is pushed forward and the wheels 1 and 2 caused to rotate, they will in turn cause rotation of the pulleys 21 and 22; which will in turn cause operation of the pulleys 23 and 24, and finally through the intermediary of the driving members 27 and 28 the pulleys 25 and 26 will be turned and thus cause the rotation of the brush shaft.

At the opposite ends of the shaft 12 are depending members 33 which may be formed of any suitable material, as for instance, sheet metal. The said members are

joined with each other by means of a transverse sheet metal member 34 which carries a double ended rake 35 upon one side of which is a series of rounded blunt projections 36 and upon the opposite side there is a series of substantially straight projections 37. The members 33 are free to swing upon the shaft 12 and when the vehicle is being pushed forward, the members 33 and the member 34 will assume the position shown in Fig. 7 of the drawing; the blunt ends of the rake being toward the ground. This will form a surface against which the brush may act so as to brush the material in front of the cleaner into the receptacle.

When the device is used to clean a street for instance, it frequently becomes necessary to use a scraping member to dislodge heavy dirt which may have collected on the street. For this purpose, I provide a scraper which comprises a flat substantially horizontal member 38 which extends transversely of the frame. This scraper is formed upon both its sides with a somewhat sharp edge. At the opposite ends of the member 38 are secured members 39 which are pivotally carried upon the shaft 12. When the scraper is in use, it will occupy a position such as is shown in Fig. 7, but when said device is not in use, it will occupy a position shown in Fig. 1, being held in position by means of a suitable catch.

If it be desired to pull the cart instead of pushing the same, as for instance, when it may be attached to the rear end of a wagon, the members 33 and 34 will assume the position shown in Fig. 8 and the sharp points of the rake will be presented to the surface which is being traversed. In this event the brushes upon the shaft 12 will be operated in a direction the reverse of their rotation when the cart is pushed and it will be necessary to provide some means for deflecting the course of the material which is gathered by the brushes so that it will enter the receptacle 1. For this purpose, I provide a curved deflector 40 which is mounted upon the side members 5 and 6 in a position relative to the other parts of the cleaner as shown in Figs. 7 and 8. This deflector will direct the material gathered by the brush so that it will enter the receptacle 47. The scraper may also be used to cooperate with the brush when the cart is being pulled as shown in Fig. 8. The scraper 38 is allowed some play upon the shaft 12 so that it may be sprung past the rake 35 and the deflector 40.

In cleaning a lawn or similar surface, it very frequently happens that there are hollow places therein, and to effectively clean the material which may collect within these hollow places, it may be desirable to lower the one end of the brush below the other end. In order to accomplish this result, I

have provided the particular mounting of the forward end of the vehicle as shown.

Upon the forward end of the member 6 is pivoted a lever 41. This lever extends below the member 6 and its lower end is provided with a wheel 42 which is adapted to rest upon the surface being traversed. The lever 41 extends somewhat above the member 6 and at its upper end a rod 43 is pivoted thereto. This member extends toward the upper part of the member 6 and is provided with an inwardly extended portion 42<sup>a</sup> which is adapted to cooperate with a series of notches 43<sup>a</sup> formed in the upper part of the member 6. The member 5 is also provided with a series of notches 44 with which the bent end of the rod 45 cooperates. This rod 45 is pivoted upon a lever 46 which in turn is pivoted upon the member 5 and carries a wheel at the lower end thereof in a manner similar to that previously described. From this construction, it will be seen that the rods 43 and 45 may be operated to move the levers 41 and 46 into a more or less vertical position which will in turn cause the corresponding corner of the vehicle to be raised or lowered according to whether the members 43 and 45 are pushed forward or pulled toward the rear. In this manner, it will be possible to lower one corner of the forward part of the vehicle without lowering the other and thus permit one end of the brush to be lowered with respect to the other. The flexible arrangement of the frame together with the flexible belts which operatively connect the various pulleys permits this adjusting feature.

A receptacle 47 occupies a position between the members 5 and 6 and rests upon the portion 4 of the drop axle and its forward end rests upon the cross rods 10 and 11. The receptacle is mounted in a manner so as to slant toward the front. A cleat 48 upon the lower part of the receptacle 47 is adapted to engage with the portion 4 of the axle so as to hold the receptacle 47 in its position and prevent its dislodgment. When it is desired to remove the receptacle, it is lifted so that the cleat 48 clears the portion 4 of the axle.

The rear end of the receptacle 47 may be hooked to the side members 5 and 6, as indicated at 48, if such be desired.

Having thus described my invention what I claim is:

1. In a device of the character described, the combination of a frame, a holding receptacle mounted upon said frame, a rotary brush journaled upon the frame in front of the holding receptacle, a deflector mounted upon the frame and partially encircling the brush, a rake pivotally mounted upon the frame and extending beneath and parallel with the brush, said rake being adapted to be moved about a pivotal point to cooperate

with the brush to gather and direct the material carried by the brush into the holding receptacle.

2. In a device of the character described, the combination of a frame, a holding receptacle mounted upon said frame, a rotary brush mounted upon the frame, a scraper pivotally mounted upon the frame concentrically with the axis of the brush, said scraper extending beneath the brush, the scraper and brush cooperating to remove material from the surface upon which the device is operating, said scraper being adapted to be swung upon its pivots away from beneath the brush.

3. In a device of the character described, the combination of a frame with a holding receptacle mounted upon said frame, a rotary brush mounted upon the frame and in front of the holding receptacle, a rake pivotally mounted upon the frame extending below and parallel with the brush, said rake in one position engaging the holding receptacle and cooperating with the brush when the said brush is rotated in a forward direction to sweep the material operated upon into the holding receptacle, a deflector mounted upon said frame in front of the brush and partly covering the same, said rake member being adapted to swing on its pivots to a point adjacent the deflector and to cooperate with the brush when the brush is rotated in a rearward direction to direct material against the deflector and thence into the holding receptacle.

4. In a device of the character described, the combination of a frame having handles, wheels upon the frame, a rotary brush mounted at the forward end of the frame, and means operated from the handles for independently adjusting the opposite ends of the brush.

5. In a device of the character described, the combination with a frame having handles, wheels upon which said frame is mounted, wheels upon the forward end of said frame, and means operated from the handle for independently adjusting the position of the last mentioned wheels whereby the forward end of the frame may be raised or lowered.

6. In a device of the character described, the combination with a frame, wheels upon which said frame is mounted, levers pivoted upon the forward ends of the frame at opposite sides thereof, wheels carried on the lower ends of said levers, and operating rods secured to the upper ends of said levers for operating the same, whereby the height of the opposite sides of the forward end of the vehicle may be independently adjusted.

7. In a device of the character described, the combination of a frame, wheels upon said frame, levers pivoted upon the opposite ends of the forward portion of said frame,

wheels at the lower ends of said lever, rods at the upper ends of said lever for moving the same whereby the height of the opposite sides of the forward end of the frame may be independently adjusted, a rotary brush carried upon the forward end of the frame, and driving connections between the first mentioned wheels and the brush.

8. In a device of the character described, the combination with a frame having handles, wheels upon which said frame is mounted, wheels upon the forward end of said frame, means extending to the handles for independently adjusting the position of the last mentioned wheels whereby the forward corners of the frame may be independently raised or lowered, a rotary brush mounted upon the frame in position to engage the surface upon which the wheels rest, and means for rotating said brush when the wheels are rotated.

9. In a device of the character described, the combination with a frame, wheels upon which said frame is mounted, wheels upon the forward end of said frame, and means for adjusting the position of the last mentioned wheels whereby either side of the forward end of the frame may be independently raised or lowered, a holding receptacle mounted upon said frame, a rotary brush mounted upon the frame adjacent said holding receptacle, a rake pivotally se-

cured upon the frame extending below and adjacent the brush and adapted to cooperate with the brush when the same is operated.

10. In a device of the character described, the combination with an axle, wheels upon said axle, of a frame, said frame comprising side pieces pivotally mounted upon said axle, members connecting the side pieces with each other which permit limited relative movement between the side pieces, a brush carried by the frame at the forward end thereof, and a holding receptacle supported by the frame and axle.

11. In a device of the character described, the combination with a frame comprising side pieces, journal boxes mounted upon the side pieces near the forward end thereof, balls within the said journal boxes, a shaft extending beyond the journal boxes and engaging with the balls therein, a brush carried by said shaft rods flexibly connecting the side pieces together, wheels upon which the said frame is mounted and operative connections between the wheels and the shaft for operating the same.

In testimony whereof, I hereunto affix my signature in the presence of two witnesses.

JOSEPH A. HUMM.

Witnesses:

Fritz Rudin,  
T. O'Hern.