

(No Model.)

T. W. VARE.  
VISE JAW.

No. 525,243.

Patented Aug. 28, 1894.

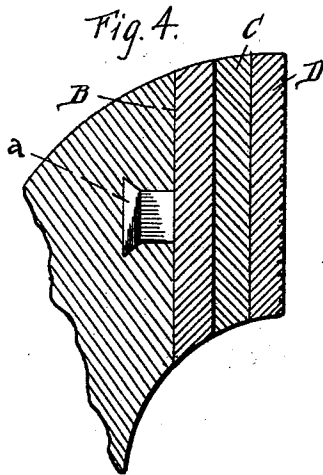
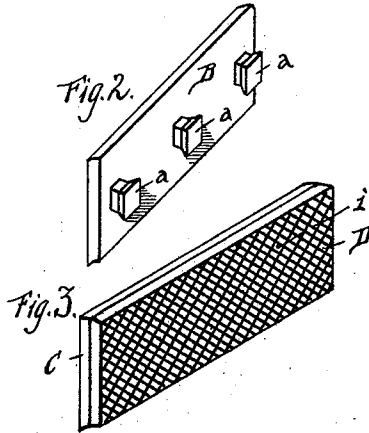
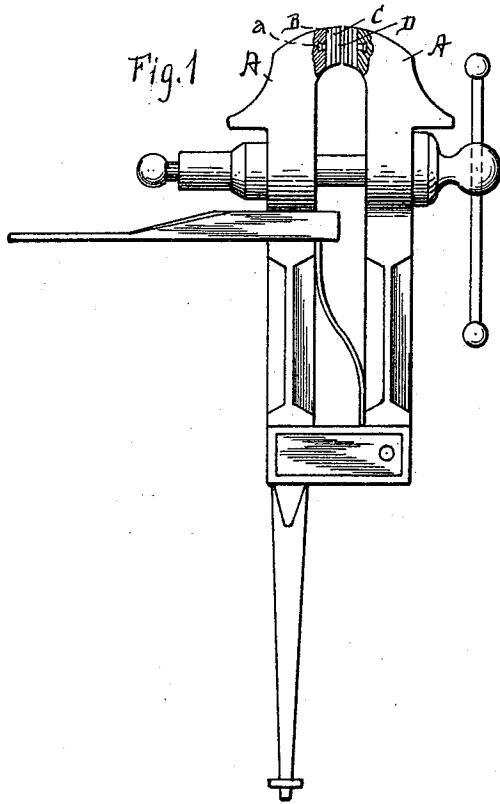

WITNESSES

*Geo. M. Anderson*  
*Philip Cassi.*

INVENTOR

*Thomas W. Vare,*

*By E. W. Anderson*

*his Attorney*

# UNITED STATES PATENT OFFICE.

THOMAS W. VARE, OF TRENTON, NEW JERSEY.

## WISE-JAW.

SPECIFICATION forming part of Letters Patent No. 525,243, dated August 28, 1894.

Application filed May 10, 1894. Serial No. 510,720. (No model.)

*To all whom it may concern:*

Be it known that I, THOMAS W. VARE, a citizen of the United States, and a resident of Trenton, in the county of Mercer and State of New Jersey, have invented certain new and useful improvements in Vise-Jaws; and I do declare the following to be a full, clear, and exact description of the invention, such as will enable others skilled in the art to which it appertains to make and use the same, reference being had to the accompanying drawings, and to letters of reference marked thereon, which form a part of this specification.

Figure 1 of the drawings is a representation of a side elevation of the invention applied. Fig. 2 is a perspective view of anchor plate. Fig. 3 is a perspective view of the jaw and face plates. Fig. 4 is a cross-section of the invention detached from the body of jaw.

This invention has relation to certain new and useful improvements in vise jaws, and it consists in the novel construction and combination of parts, all as hereinafter described and pointed out in the appended claims.

The object of my invention is to provide a vise jaw the body of which is formed from malleable iron, but having a face or jaw proper of steel joined thereto in a perfectly rigid, solid, and secure manner. Heretofore vise jaws have usually been made of wrought iron with steel face pieces, malleable iron not being used for the reason that there has been no practicable and satisfactory manner of securing the steel face thereto. By the present invention, I am enabled to employ malleable iron for the body of the jaw, thus reducing the cost of manufacture, and at the same time providing an equally good article.

In the accompanying drawings I have shown a form of vise constructed with my improved jaw, although such jaws may be employed with various kinds of vises.

Referring to the drawings, the letter A designates the body of the jaw, B an anchor plate of wrought iron, C a jaw plate, also of wrought iron, and brazed to the anchor plate, and D the face plate of steel welded to the said jaw plate. In manufacturing this jaw, I first provide the anchor plate B of wrought iron, and formed upon one face with anchor projections

a, larger at their extremities than at the plate. This plate I place in the mold for the body of the jaw, and cast the latter onto it, said anchor plate and body being by this operation, partially welded together and partially anchored. The wrought iron jaw plate and the steel face plate, which are welded together, are next applied to the anchor plate in connection with a suitable braze, such as copper, and the parts are placed in a furnace and heated to melt the braze. They are then taken from the furnace and placed under a suitable press, sufficient force being applied to set the parts firmly together. The braze solidly unites the two wrought iron plates, and also flows around and into any cavities that may exist in the joint between the body of the jaw and the anchor plate.

Where it is desired to form the face plate of the jaw with teeth or corrugations a die similar configuration may be employed in the press having a similar configuration.

Having thus described my invention, what I claim as new, and desire to secure by Letters Patent, is—

1. The herein described vise jaw, comprising a body portion of malleable iron, an anchor plate having projections cast into said body portion, a wrought iron plate brazed to said anchor plate, and a steel face plate welded to said wrought iron plate, substantially as specified.

2. A vise jaw having a body portion of malleable iron, an anchor plate secured thereto, and a steel face plate having a back of wrought iron brazed to said anchor plate, substantially as specified.

3. A vise jaw comprising a body portion of malleable iron, a wrought iron anchor plate secured thereto, a wrought iron jaw plate brazed to said anchor plate, and a steel face plate welded to said jaw plate, substantially as specified.

In testimony whereof I affix my signature in presence of two witnesses.

THOMAS W. VARE.

Witnesses:

ISRAEL HOWELL,  
FREDERICK F. HOWELL,