

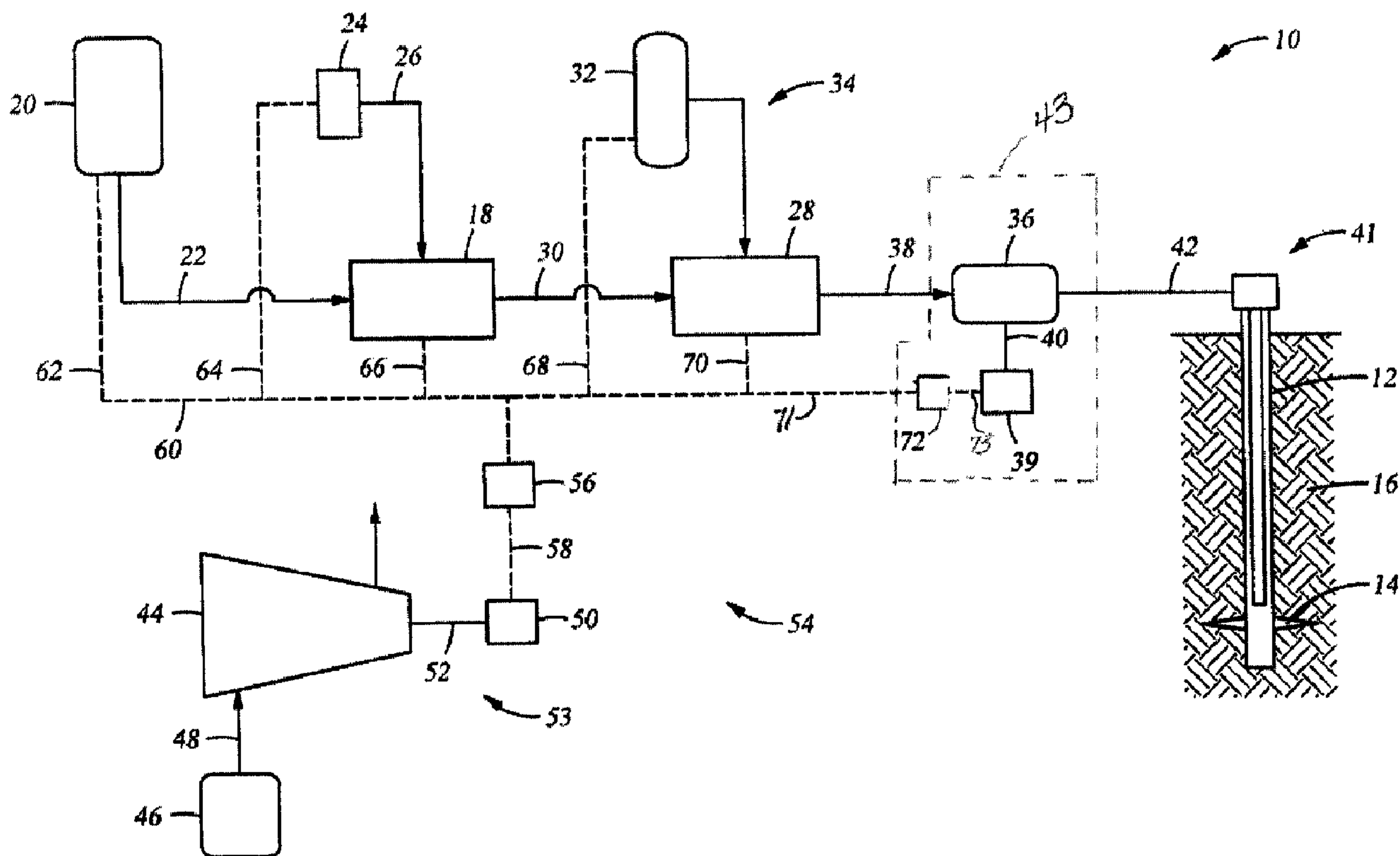

(22) **Date de dépôt/Filing Date:** 2016/07/22
 (41) **Mise à la disp. pub./Open to Public Insp.:** 2017/01/24
 (30) **Priorités/Priorities:** 2015/07/24 (US62/196,350);
 2016/07/22 (US15/217,040)

(51) **Cl.Int./Int.Cl.** *E21B 43/26* (2006.01),
E21B 41/00 (2006.01), *G08B 5/36* (2006.01),
F21S 10/02 (2006.01)
 (71) **Demandeur/Applicant:**
 US WELL SERVICES LLC, US
 (72) **Inventeurs/Inventors:**
 OEHRING, JARED, US;
 HINDERLITER, BRANDON, US
 (74) **Agent:** FINLAYSON & SINGLEHURST

(54) **Titre : TEMOINS DE SECURITE DESTINES A DES POMPES DE FRACTURATION HYDRAULIQUE**
 (54) **Title: SAFETY INDICATOR LIGHTS FOR HYDRAULIC FRACTURING PUMPS**



(57) **Abrégé/Abstract:**

A hydraulic fracturing system includes an electrically powered pump that pressurizes fluid, which is piped into a wellbore to fracture a subterranean formation. System components include a fluid source, an additive source, a hydration unit, a blending unit, a

(57) Abrégé(suite)/Abstract(continued):

proppant source, a fracturing pump, and an electrically powered motor for driving the pump. Also included with the system is a signal assembly that visually displays operational states of the pump and motor, thereby indicating if fluid discharge lines from the pump contain pressurized fluid. The visual display of the signal assembly also can indicate if the motor is energized, so that the discharge lines might soon contain pressurized fluid.

ABSTRACT

A hydraulic fracturing system includes an electrically powered pump that pressurizes fluid, which is piped into a wellbore to fracture a subterranean formation. System components include a fluid source, an additive source, a hydration unit, a blending unit, a proppant source, a fracturing pump, and an electrically powered motor for driving the pump. Also included with the system is a signal assembly that visually displays operational states of the pump and motor, thereby indicating if fluid discharge lines from the pump contain pressurized fluid. The visual display of the signal assembly also can indicate if the motor is energized, so that the discharge lines might soon contain pressurized fluid.

SAFETY INDICATOR LIGHTS FOR HYDRAULIC FRACTURING PUMPS**CROSS REFERENCE TO RELATED APPLICATIONS**

[0001] This application claims priority to and the benefit of, co-pending U.S. Provisional Application Serial No. 62/196,350, filed July 24, 2015 and is a continuation-in-part of, and claims priority to and the benefit of co-pending U.S. Patent Application Serial No. 13/679,689, filed November 16, 2012, the full disclosures of which are hereby incorporated by reference herein for all purposes.

BACKGROUND OF THE INVENTION**1. Field of Invention**

[0002] The present disclosure relates to hydraulic fracturing of subterranean formations. In particular, the present disclosure relates to an electrical hydraulic fracturing system having different colored lights that are selectively illuminated to indicate an operational state of the fracturing system.

2. Description of Prior Art

[0003] Hydraulic fracturing is a technique used to stimulate production from some hydrocarbon producing wells. The technique usually involves injecting fluid into a wellbore at a pressure sufficient to generate fissures in the formation surrounding the wellbore. Typically the pressurized fluid is injected into a portion of the wellbore that is pressure isolated from the remaining length of the wellbore so that fracturing is limited to a designated portion of the formation. The fracturing fluid slurry, whose primary component is usually water, includes proppant (such as sand or ceramic) that migrate into the fractures with the fracturing fluid slurry

and remain to prop open the fractures after pressure is no longer applied to the wellbore. A primary fluid for the slurry other than water, such as nitrogen, carbon dioxide, foam (nitrogen and water), diesel, or other fluids is sometimes used as the primary component instead of water. Typically hydraulic fracturing fleets include a data van unit, blender unit, hydration unit, chemical additive unit, hydraulic fracturing pump unit, sand equipment, and other equipment.

[0004] Traditionally, the fracturing fluid slurry has been pressurized on surface by high pressure pumps powered by diesel engines. To produce the pressures required for hydraulic fracturing, the pumps and associated engines have substantial volume and mass. Heavy duty trailers, skids, or trucks are required for transporting the large and heavy pumps and engines to sites where wellbores are being fractured. Each hydraulic fracturing pump is usually composed of a power end and a fluid end. The hydraulic fracturing pump also generally contains seats, valves, a spring, and keepers internally. These parts allow the hydraulic fracturing pump to draw in low pressure fluid slurry (approximately 100 psi) and discharge the same fluid slurry at high pressures (over 10,000 psi). Recently electrical motors controlled by variable frequency drives have been introduced to replace the diesel engines and transmission, which greatly reduces the noise, emissions, and vibrations generated by the equipment during operation, as well as its size footprint.

[0005] On each separate unit, a closed circuit hydraulic fluid system is often used for operating auxiliary portions of each type of equipment. These auxiliary components may include dry or liquid chemical pumps, augers, cooling fans, fluid pumps, valves, actuators, greasers, mechanical lubrication, mechanical cooling, mixing paddles, landing gear, and other needed or desired components. This hydraulic fluid system is typically separate and independent of the main hydraulic fracturing fluid slurry that is being pumped into the wellbore. The lines carrying the

pressurized fluid from the pumps, often referred to as discharge iron, can fail without warning. Metal shrapnel or the high pressure fluid slurry from the failed discharge iron can cause personal injury to any personnel proximate the failure. While the best way to avoid personal injury is for operations personnel to avoid zones proximate the discharge iron, maintenance or inspection requires entry into these zones.

SUMMARY OF THE INVENTION

[0006] Disclosed herein is an example of a hydraulic fracturing system for fracturing a subterranean formation, and which includes a plurality of electric pumps fluidly connected to the formation, and powered by at least one electric motor, and configured to pump fluid at high pressure into a wellbore that intersects the formation, so that the fluid passes from the wellbore into the formation, and fractures the formation, a variable frequency drive connected to the electric motor to control the speed of the motor, wherein the variable frequency drive frequently performs electric motor diagnostics to prevent damage to the at least one electric motor, and a signal assembly that selectively emits a visual signal that is indicative of an operational state of the hydraulic fracturing system. In an example, the signal assembly includes a plurality of light assemblies arranged in a stack. In this example, each of the light assemblies selectively emit visual light of a color different from visual light emitted by other light assemblies. Further in this example, a distinctive operational state of the system is indicated by illumination of a combination of the light assemblies. Example operational states of the hydraulic fracturing system include, no electricity to the system, a supply of electricity to all electrically powered devices in the system, a supply of electricity to some of the electrically powered devices in the system, and a pressure in a discharge line of the pump having a magnitude that is at least that of a designated pressure. A controller can be included that is in communication with the variable frequency drive, a pressure indicator that senses pressure in a discharge line of a one of the pumps, and the signal assembly. In this example, the controller selectively activates the signal assembly in response to a communication signal from one of the variable frequency drive or the pressure indicator, or directly from a command signal from an operator controlled computer. Optionally the visual signal is made up of light in the visible spectrum, and that is optically

detectable by operations personnel disposed in a zone that is potentially hazardous due to fluid in piping that is pressurized by at least one of the pumps.

[0007] Also described herein is an example of a hydraulic fracturing system for fracturing a subterranean formation and which includes a pump having a discharge in communication with a wellbore that intersects the formation, an electric motor coupled to and that drives the pump, a variable frequency drive connected to the electric motor that controls a speed of the motor and performs electric motor diagnostics, a signal assembly that selectively emits different visual signals that are distinctive of an operational state of the system, and a controller in communication with the signal assembly, and that selectively transmits a command signal to the signal assembly in response to a monitoring signal received by the controller and transmitted from a device in the system. Examples exist wherein the device in the system that transmits the monitoring signal to the controller can be a variable frequency drive or a pressure monitor in fluid communication with the discharge of the pump. The signal assembly can be a stack of light assemblies. In one embodiment, light assemblies each are made up of an electrically powered light source, and that each emit light of a color that is different from a color of a light emitted by the other light assemblies. In an alternative, further included with the system is a pump controller and auxiliary equipment, and wherein the operational state of the system can be, the system being isolated from electricity, a fluid pressure of the discharge having a value at least as great as a designated value, the pump controller being energized, and the auxiliary equipment being energized but without a one of the motors being energized. The visual signals can selectively indicate when the system is safe for operations personnel, when the system is potentially unsafe for operations personnel, and when the system is currently unsafe for operations personnel.

[0008] An example of a method of fracturing a subterranean formation is also described herein and which includes pressurizing fracturing fluid with a pump, driving the pump with a motor that is powered by electricity, monitoring an operational state of a hydraulic fracturing system that comprises the pump and motor, and selectively emitting a visual signal that is indicative of the monitored operational state. The operational state of the system includes isolation from electricity, a fluid pressure of the discharge of the pump having a value at least as great as a designated value, the pump controller being energized, and the auxiliary equipment being energized but without a one of the motors being energized. Selectively emitting a visual signal can be emitting a light from one or more of a stack of light assemblies, where light from one of the stack of light assemblies is different from lights emitted from other light assemblies. The method can further include monitoring electricity to a variable frequency drive, wherein the variable frequency drive controls electricity to the motor. The method can optionally include monitoring a fluid pressure of the discharge of the pump.

BRIEF DESCRIPTION OF DRAWINGS

[0009] Some of the features and benefits of the present invention having been stated, others will become apparent as the description proceeds when taken in conjunction with the accompanying drawings, in which:

[0010] FIG. 1 is a schematic of an example of a hydraulic fracturing system.

[0011] FIG. 2 is a plan schematic view of an example of a fracturing pump system having signal assemblies.

[0012] FIG. 3 is a perspective view of an example of a signal assembly and which is in communication with a controller.

[0013] FIGS. 4A-4H are perspective views of examples of the signal assembly of FIG. 3 in different signal configurations.

[0014] While the invention will be described in connection with the preferred embodiments, it will be understood that it is not intended to limit the invention to that embodiment. On the contrary, it is intended to cover all alternatives, modifications, and equivalents, as may be included within the spirit and scope of the invention as defined by the appended claims.

DETAILED DESCRIPTION OF INVENTION

[0015] The method and system of the present disclosure will now be described more fully hereinafter with reference to the accompanying drawings in which embodiments are shown. The method and system of the present disclosure may be in many different forms and should not be construed as limited to the illustrated embodiments set forth herein; rather, these embodiments are provided so that this disclosure will be thorough and complete, and will fully convey its scope to those skilled in the art. Like numbers refer to like elements throughout. In an embodiment, usage of the term “about” includes +/- 5% of the cited magnitude. In an embodiment, usage of the term “substantially” includes +/- 5% of the cited magnitude.

[0016] It is to be further understood that the scope of the present disclosure is not limited to the exact details of construction, operation, exact materials, or embodiments shown and described, as modifications and equivalents will be apparent to one skilled in the art. In the drawings and specification, there have been disclosed illustrative embodiments and, although specific terms are employed, they are used in a generic and descriptive sense only and not for the purpose of limitation.

[0017] Figure 1 is a schematic example of a hydraulic fracturing system 10 that is used for pressurizing a wellbore 12 to create fractures 14 in a subterranean formation 16 that surrounds the wellbore 12. Included with the system 10 is a hydration unit 18 that receives fluid from a fluid source 20 via line 22, and also selectively receives additives from an additive source 24 via line 26. Additive source 24 can be separate from the hydration unit 18 as a stand-alone unit, or can be included as part of the same unit as the hydration unit 18. The fluid, which in one example is water, is mixed inside of the hydration unit 18 with the additives. In an embodiment,

the fluid and additives are mixed over a period of time to allow for uniform distribution of the additives within the fluid. In the example of Figure 1, the fluid and additive mixture is transferred to a blender unit 28 via line 30. A proppant source 32 contains proppant, which is delivered to the blender unit 28 as represented by line 34, where line 34 can be a conveyer. Inside the blender unit 28, the proppant and fluid/additive mixture are combined to form a fracturing slurry, which is then transferred to a fracturing pump assembly 36 via line 38; thus fluid in line 38 includes the discharge of blender unit 28, which is the suction (or boost) for the fracturing pump assembly 36. Blender unit 28 can have an onboard chemical additive system, such as with chemical pumps and augers. Optionally, additive source 24 can provide chemicals to blender unit 28; or a separate and standalone chemical additive system (not shown) can be provided for delivering chemicals to the blender unit 28. In an example, the pressure of the slurry in line 38 ranges from around 80 psi to around 100 psi. The pressure of the slurry can be increased up to around 15,000 psi by fracturing pump assembly 36. A motor 39, which connects to fracturing pump assembly 36 via connection 40, drives fracturing pump assembly 36 so that it can pressurize the slurry. After being discharged from fracturing pump assembly 36, slurry is injected into a wellhead assembly 41; discharge piping 42 connects discharge of fracturing pump assembly 36 with wellhead assembly 41 and provides a conduit for the slurry between the fracturing pump assembly 36 and the wellhead assembly 41. The fracturing pump assembly 36, motor 39, connection 40, lines 38, piping 42, VFD 72, and line 73 define one example of a fracturing pump system 43. In an alternative, hoses or other connections can be used to provide a conduit for the slurry between the pump assembly 36 and the wellhead assembly 41. Optionally, any type of fluid can be pressurized by the fracturing pump assembly 36 to form injection fracturing fluid that is then pumped into the wellbore 12 for fracturing the formation 14,

and is not limited to fluids having chemicals or proppant. Examples exist wherein the system 10 includes multiple fracturing pump assemblies 36, and multiple motors 39 for driving the multiple fracturing pump assemblies 36. Examples also exist wherein the system 10 includes the ability to pump down equipment, instrumentation, or other retrievable items through the slurry into the wellbore.

[0018] An example of a turbine 44 is provided in the example of Figure 1 and which receives a combustible fuel from a fuel source 46 via a feed line 48. In one example, the combustible fuel is natural gas, and the fuel source 46 can be a container of natural gas or a well (not shown) proximate the turbine 44. Combustion of the fuel in the turbine 44 in turn powers a generator 50 that produces electricity. Shaft 52 connects generator 50 to turbine 44. The combination of the turbine 44, generator 50, and shaft 52 define a turbine generator 53. In another example, gearing can also be used to connect the turbine 44 and generator 50. An example of a micro-grid 54 is further illustrated in Figure 1, and which distributes electricity generated by the turbine generator 53. Included with the micro-grid 54 is a transformer 56 for stepping down voltage of the electricity generated by the generator 50 to a voltage more compatible for use by electrical powered devices in the hydraulic fracturing system 10. In another example, the power generated by the turbine generator and the power utilized by the electrical powered devices in the hydraulic fracturing system 10 are of the same voltage, such as 4160 V so that main power transformers are not needed. In one embodiment, multiple 3500 kVA dry cast coil transformers are utilized. Electricity generated in generator 50 is conveyed to transformer 56 via line 58. In one example, transformer 56 steps the voltage down from 13.8 kV to around 600 V. Other stepped down voltages can include 4,160 V, 480 V, or other voltages. The output or low voltage side of the transformer 56 connects to a power bus 60, lines 62, 64, 66, 68, 70, and 71 connect to power bus

60 and deliver electricity to electrically powered end users in the system 10. More specifically, line 62 connects fluid source 20 to bus 60, line 64 connects additive source 24 to bus 60, line 66 connects hydration unit 18 to bus 60, line 68 connects proppant source 32 to bus 60, line 70 connects blender unit 28 to bus 60, and line 71 connects bus 60 to an optional variable frequency drive (“VFD”) 72. Line 73 connects VFD 72 to motor 39. In one example, VFD 72 selectively provides electrical power to motor 39 via line 73, and can be used to control operation of motor 39, and thus also operation of pump 36.

[0019] In an example, additive source 24 contains ten or more chemical pumps for supplementing the existing chemical pumps on the hydration unit 18 and blender unit 28. Chemicals from the additive source 24 can be delivered via lines 26 to either the hydration unit 18 and/or the blender unit 28. In one embodiment, the elements of the system 10 are mobile and can be readily transported to a wellsite adjacent the wellbore 12, such as on trailers or other platforms equipped with wheels or tracks.

[0020] Referring now to Figure 2 shown in a plan view is an alternate embodiment of a fracturing pump system 43 where a plurality of pumps 80_{1-n} , 82_{1-n} are shown mounted on a number of trailers 84_{1-n} . Also included in the fracturing pump system 43A are motors 86_{1-n} , 88_{1-n} which are mounted onto trailers 84_{1-n} and adjacent to each of the pumps 80_{1-n} , 82_{1-n} . A suction header 90 is shown connected to a line 38A and which provides fracturing fluid to a suction side of each of the pumps 80_{1-n} , 82_{1-n} via suction leads 92_{1-n} , 94_{1-n} . Similarly, fluid exits the pumps 80_{1-n} , 82_{1-n} via discharge leads 96_{1-n} , 98_{1-n} that connect to the discharge side of each of the pumps 80_{1-n} , 82_{1-n} . Discharge leads 96_{1-n} , 98_{1-n} each connect to a discharge header 99, which routes the pressurized discharge fluid from the leads 96_{1-n} , 98_{1-n} to discharge piping 42A, where the pressurized fracturing fluid can be transported to wellbore 12 of Figure 1. Signal assemblies

100_{1-n}, 102_{1-n} are shown provided on the trailers 84_{1-n} and which selectively emit visual signals that are indicative of an operational state of the fracturing pump system 43A. Examples of operational states include one where the trailers 84_{1-n} having the signal assemblies 100_{1-n}, 102_{1-n} have no electricity provided to them and thus are unpowered and are safe for maintenance. Another example of an operational state is when fluid in the discharge piping, such as the discharge leads 96_{1-n}, 98_{1-n} exceeds a designated value, for example, when discharge piping is at 100 pounds per square inch or greater. In the example of Figure 2, the signal assemblies 100_{1-n}, 102_{1-n} are shown mounted on radiators 104_{1-n}, 106_{1-n} that are provided on the motors 86_{1-n}, 88_{1-n}. However, signal assemblies 100_{1-n}, 102_{1-n} can be disposed at any location on trailers 84_{1-n}, or adjacent trailers 84_{1-n} so that operations personnel can readily view visible signals emitted by these signal assemblies 100_{1-n}, 102_{1-n}.

[0021] Referring now to Figure 3, illustrated is a schematic example of how the signal assemblies 100_{1-n}, 102_{1-n} of Figure 2 are selectively illuminated. Here, example signal assemblies 100_i, 102_i are illustrated in perspective view and which are made up of individual light assemblies 108₁₋₃ that are set on one another to form a stack 110. In this example, each light assembly 108₁₋₃ includes a lens 112₁₋₃ which is a layer of translucent or transparent material that has a curved outer surface and circumscribes a light source 114₁₋₃ within the light assembly 108₁₋₃. Either the lens 112₁₋₃ or light source 114₁₋₃ can be formed of a different color from the other lenses 112₁₋₃ or light sources 114₁₋₃, so that if one of the light sources 114₁₋₃ is illuminated, light is projected from that illuminated light sources 114₁₋₃ that has a color that is different from a color of a light emitted by any of the other light assemblies 108₁₋₃. Example colors include green, orange, and red. Electricity for illuminating the light sources 114₁₋₃ can be provided from a power source 116 which connects to the signal light sources 114₁₋₃ via an electrically

conducting line 118. Individual leads 120_{1-3} are shown that connect line 118 to light sources 114_{1-3} , and which provide selective power to the light sources 114_{1-3} . In this way any combination of the light sources 114_{1-3} can be illuminated at one time. A controller 122 is schematically illustrated and which communicates with power source 116 via a communication means 124. Thus, control signals from controller 122 directed to power source 116 control the selective illumination of the individual light sources 114_{1-3} . Controller 122 is also in communication with a pressure indicator 126 which is shown on discharge leads 96_i , 98_i . Optionally, a pressure indicator 126 can be provided on discharge outlets of each of pumps 80_{1-n} , 82_{1-n} (Figure 2). In Figure 3, subscript “i” represents any of numbers 1 through n of Figure 2. Values of pressure measured by pressure indicator 126 within discharge leads 96_i , 98_i are transmitted to controller 122 via communication means 128. A check valve 130 is shown in the discharge leads 96_i , 98_i and upstream of where the leads 96_i , 98_i intersect with discharge header 99, and which allows flow from leads 96_i , 98_i to header 99, but is to block flow from header 99 to leads 96_i , 98_i . Further, communication means 132 provides communication between controller 122 and variable frequency drives (“VFD”) 134_i , 136_i . Each of the communication means 124, 128, 132 can be hard-wired, such as conductive elements or optical cables. Communication means 124, 128, 132 can be wireless as well. Variable frequency drives 134_i , 136_i , in one example, operate substantially similar to variable frequency drive 72 of Figure 1.

[0022] Referring back to Figure 2, variable frequency drives 134_{1-n} , 136_{1-n} are shown provided with each trailer 84_{1-n} and that are in electrical communication with electrical power downstream of transformer 56 via lines 138_{1-n} , 140_{1-n} . Electrical power from the VFDs 134_{1-n} , 136_{1-n} is selectively provided to motors 86_{1-n} , 88_{1-n} through lines 142_{1-n} , 144_{1-n} . The VFDs 134_{1-n} , 136_{1-n} provide control to the motors and can regulate wave forms of the electrical current in order to

operate the motors 86_{1-n}, 88_{1-n} at designated values of RPM, torque, or other operational parameters. Pump controllers 146_{1-n}, 147_{1-n} are shown that provide selective input to junction box controllers 148_{1-n}, 149_{1-n} via signal lines 150_{1-n}, 151_{1-n}. In the illustrated example junction box controllers 148_{1-n}, 149_{1-n} provide controlling functionality for many of the devices on trailers 84_{1-n}. In an example, each of junction box controllers 148_{1-n}, 149_{1-n} is equipped with a controller 122 (Figure 3) for controlling operation of signal assemblies 100_{1-n}, 102_{1-n}. Further illustrated is that junction box controllers 148_{1-n}, 149_{1-n} are in controlling communication with the VFDs 134_{1-n}, 136_{1-n} via signal lines 152_{1-n}, 153_{1-n}. As shown, the pump controllers 146_{1-n}, 147_{1-n} are remote from the fracturing pump system 43A and in one example are manipulated by operations personnel in order to operate the pumps 80_{1-n}, 82_{1-n} at designated operational conditions. Examples exist where pump controllers 146_{1-n}, 147_{1-n} are separate consoles for each pump 80_{1-n}, 82_{1-n}, or are combined into a single unit. Further schematically illustrated in Figure 2 are motor control center devices 154_{1-n} which represent devices that provide power to auxiliary devices provided with the trailers 84_{1-n}.

[0023] Figures 4A through 4H illustrate various combinations of how the light assemblies 108₁₋₃ might be illuminated to visually convey an indication of an operational state of the fracturing pump system 43A. As shown in Figure 4A, none of the light assemblies 108₁₋₃ are illuminated which in this examples indicates that no electrical power is being delivered to the particular VFD 134_{1-n}, 136_{1-n} (Figure 2) associated with the stack 110. For example, referring back to Figure 2, it should be pointed out that a signal assembly is associated with a particular VFD that distributes electricity to the motor 86_{1-n}, 88_{1-n} adjacent where the signal assembly 100_{1-n}, 102_{1-n} is located; thus in the example of Figure 2, signal assembly 100₁ is associated with VFD 134₁, signal assembly 102₁ is associated with VFD 136₁, and so on. Referring now to Figure 4B, light

assembly 108₃ is shown to be illuminated whereas light assemblies 108₁, 108₂ are not. In an example, selectively illuminating light assembly 108₃, while not illuminating the other light assemblies 108_{1, 2}, indicates that the fluid in discharge leads 96_{1-n}, 98_{1-n} is at or greater than a designated pressure. In this example, that designated pressure is at least 100 psi, which can indicate either that the plungers (not shown) within the particular pump 80_{1-n}, 82_{1-n} are not stroking and that the particular check valve 130 adjacent the pressure indicator 126 (Figure 3) has failed. A failed check valve 130 can allow pressure from the discharge header 99, which could be pressurized from a different pump, to enter into the discharge lead 96_{1-n}, 98_{1-n} thereby pressurizing the lead 96_{1-n}, 98_{1-n}. This light condition can also indicate that either light assembly 108₁ or light assembly 108₂ has failed. This is because illumination of light assembly 108₁ indicates there is electrical power to the particular trailer 84_{1-n} on which the light assemblies 108₁, 108₂ are located and that electricity is not flowing from the VFDs 134_{1-n}, 136_{1-n} to the motors 86_{1-n}, 88_{1-n}. Light assembly 108₂ being illuminated indicates there is electrical power being supplied to the trailer 84_{1-n} on which the light assemblies 108₁, 108₂ are located, and that electricity may be flowing from the VFDs 134_{1-n}, 136_{1-n} to the motors 86_{1-n}, 88_{1-n}. Light assembly 108₃ cannot be illuminated if there is no power to the trailer 84_{1-n}. Figure 4C shows where only light assembly 108₂ is illuminated. This example can represent when the pump controls 146_{1-n}, 147_{1-n} of Figure 2 are engaged, but a command signal has not yet been delivered to the VFDs 134_{1-n}, 136_{1-n} which would then allow electricity from lines 138_{1-n}, 140_{1-n} to the respective motors 86_{1-n}, 88_{1-n}. In Figure 4D, only light assembly 108₁ is illuminated. An optional operational state indicated by this visual signal is that the trailer is energized, and that devices other than the motors 86_{1-n}, 88_{1-n} and VFDs 134_{1-n}, 136_{1-n} are powered, such as the auxiliary devices 154_{1-n}, but not the motors 86_{1-n}, 88_{1-n}. In Figure 4E, light assemblies 108₂, 108₃

are illuminated but no light assembly 108₁. In one embodiment, this visual signal can indicate that the pump unit is pumping under the control of the pump operator and pump controls 146_{1-n}, 147_{1-n}. Thus, in this example, the pressure in the discharge leads 96₁, 98₁ and discharge header 99, as well as discharge line 42A, are at a pressure that in some instances can fracture the discharge iron.

[0024] When the lines or iron is subject to fracture this presents a hazardous situation that operations personnel should avoid being in the area. In one example, the area of hazard is designated by the zone Z of Figure 2; and which also includes the wellhead assembly 41 of Figure 1. Thus, operations personnel from a distance can view the visual signal emitted by the signal assemblies 100_{1-n}, 102_{1-n} and avoid the area, so that in the event of a failure of a line in the discharge circuit, operations personnel are not subject to a hazardous condition and can avoid personal injury. Shown in Figure 4F is where light assemblies 108₁, 108₃ are illuminated and light assembly 108₂ is not illuminated. In this example, a check valve failure can be indicated. This condition can also indicate that the pump drive is disabled, but pump pressure from a prior operation has not yet been relieved. In Figure 4G, light assemblies 108₁, 108₂ are depicted as being illuminated, whereas light assembly 108₃ is not illuminated. Based upon the logic in the previous examples, this is an operational state that is not attainable. Thus, could be an indication that the signal assembly 100_{1-n}, 102_{1-n} is malfunctioning. Similarly, in Figure 4H, each of the light assemblies 108₁₋₃ is shown as being illuminated. This is another example where these particular light assemblies should not be illuminated at the same time, possibly indicating a failure of the signal assemblies 100_{1-n}, 102_{1-n} themselves.

[0025] The present invention described herein, therefore, is well adapted to carry out the objects and attain the ends and advantages mentioned, as well as others inherent therein. While a

presently preferred embodiment of the invention has been given for purposes of disclosure, numerous changes exist in the details of procedures for accomplishing the desired results. For example, light assemblies 108₁₋₃ can be spaced apart from one another, and in an arrangement different from a stack 110, such as horizontal or diagonal. Further, the number of light assemblies 108₁₋₃ less than or greater than three. These and other similar modifications will readily suggest themselves to those skilled in the art, and are intended to be encompassed within the spirit of the present invention disclosed herein and the scope of the appended claims.

CLAIMS

What is claimed is.

1. A hydraulic fracturing system for fracturing a subterranean formation comprising:

a plurality of electric pumps fluidly connected to the formation, and powered by at least one electric motor, and configured to pump fluid at high pressure into a wellbore that intersects the formation, so that the fluid passes from the wellbore into the formation, and fractures the formation;

a variable frequency drive connected to the electric motor to control the speed of the motor, wherein the variable frequency drive frequently performs electric motor diagnostics to prevent damage to the at least one electric motor; and

a signal assembly that selectively emits a visual signal that is indicative of an operational state of the hydraulic fracturing system.
2. The hydraulic fracturing system of Claim 1, wherein the signal assembly comprises a plurality of light assemblies arranged in a stack.
3. The hydraulic fracturing system of Claim 2, wherein each of the light assemblies selectively emit visual light of a color different from visual light emitted by other light assemblies.
4. The hydraulic fracturing system of Claim 2, wherein a distinctive operational state of the system is indicated by illumination of a combination of the light assemblies.

5. The hydraulic fracturing system of Claim 1, wherein the operational states of the hydraulic fracturing system comprise, no electricity to the system, a supply of electricity to all electrically powered devices in the system, a supply of electricity to some of the electrically powered devices in the system, and a pressure in a discharge line of the pump having a magnitude that is at least that of a designated pressure.
6. The hydraulic fracturing system of Claim 1, further comprising a controller in communication with the variable frequency drive, a pressure indicator that senses pressure in a discharge line of a one of the pumps, and the signal assembly.
7. The hydraulic fracturing system of Claim 6, wherein the controller selectively activates the signal assembly in response to a communication signal from one of the variable frequency drive or the pressure indicator.
8. The hydraulic fracturing system of Claim 1, wherein the visual signal comprises light in the visible spectrum, and that is optically detectable by operations personnel disposed in a zone that is potentially hazardous due to fluid in piping that is pressurized by at least one of the pumps.
9. A hydraulic fracturing system for fracturing a subterranean formation comprising:
 - a pump having a discharge in communication with a wellbore that intersects the formation;
 - an electric motor coupled to and that drives the pump;
 - a variable frequency drive connected to the electric motor that controls a speed of the motor and performs electric motor diagnostics;

a signal assembly that selectively emits different visual signals that are distinctive of an operational state of the system; and

a controller in communication with the signal assembly, and that selectively transmits a command signal to the signal assembly in response to a monitoring signal received by the controller and transmitted from a device in the system.

10. The hydraulic fracturing system of Claim 9, wherein the device in the system that transmits the monitoring signal to the controller comprises one of the variable frequency drive, and a pressure monitor in fluid communication with the discharge of the pump.

11. The hydraulic fracturing system of Claim 9, wherein the signal assembly comprises a stack of light assemblies.

12. The hydraulic fracturing system of Claim 11, wherein the light assemblies each comprise an electrically powered light source, and that each emit light of a color that is different from a color of a light emitted by the other light assemblies.

13. The hydraulic fracturing system of Claim 9 further comprising a pump controller and auxiliary equipment, and wherein the operational state of the system comprises, the system being isolated from electricity, a fluid pressure of the discharge having a value at least as great as a designated value, the pump drive being energized, and the auxiliary equipment being energized but without a one of the motors being energized.

14. The hydraulic fracturing system of Claim 9, wherein the visual signals selectively indicate when the system is safe for operations personnel, when the system is potentially unsafe for operations personnel, and when the system is currently unsafe for operations personnel.

15. A method of fracturing a subterranean formation comprising:
- pressurizing fracturing fluid with a pump;
 - driving the pump with a motor that is powered by electricity;
 - monitoring an operational state of a hydraulic fracturing system that comprises the pump and motor; and
 - selectively emitting a visual signal that is indicative of the monitored operational state.
16. The method of Claim 15, wherein the operational state comprises the system being isolated from electricity, a fluid pressure of the discharge of the pump having a value at least as great as a designated value, the pump controller being energized, and the auxiliary equipment being energized but without a one of the pump motors being energized.
17. The method of Claim 15, wherein the step of selectively emitting a visual signal comprises emitting a light from one or more of a stack of light assemblies, where light from one of the stack of light assemblies is different from lights emitted from other light assemblies.
18. The method of Claim 15, further comprising monitoring electricity to a variable frequency drive, wherein the variable frequency drive controls electricity to the motor.
19. The method of Claim 15, further comprising monitoring a fluid pressure of the discharge of the pump.

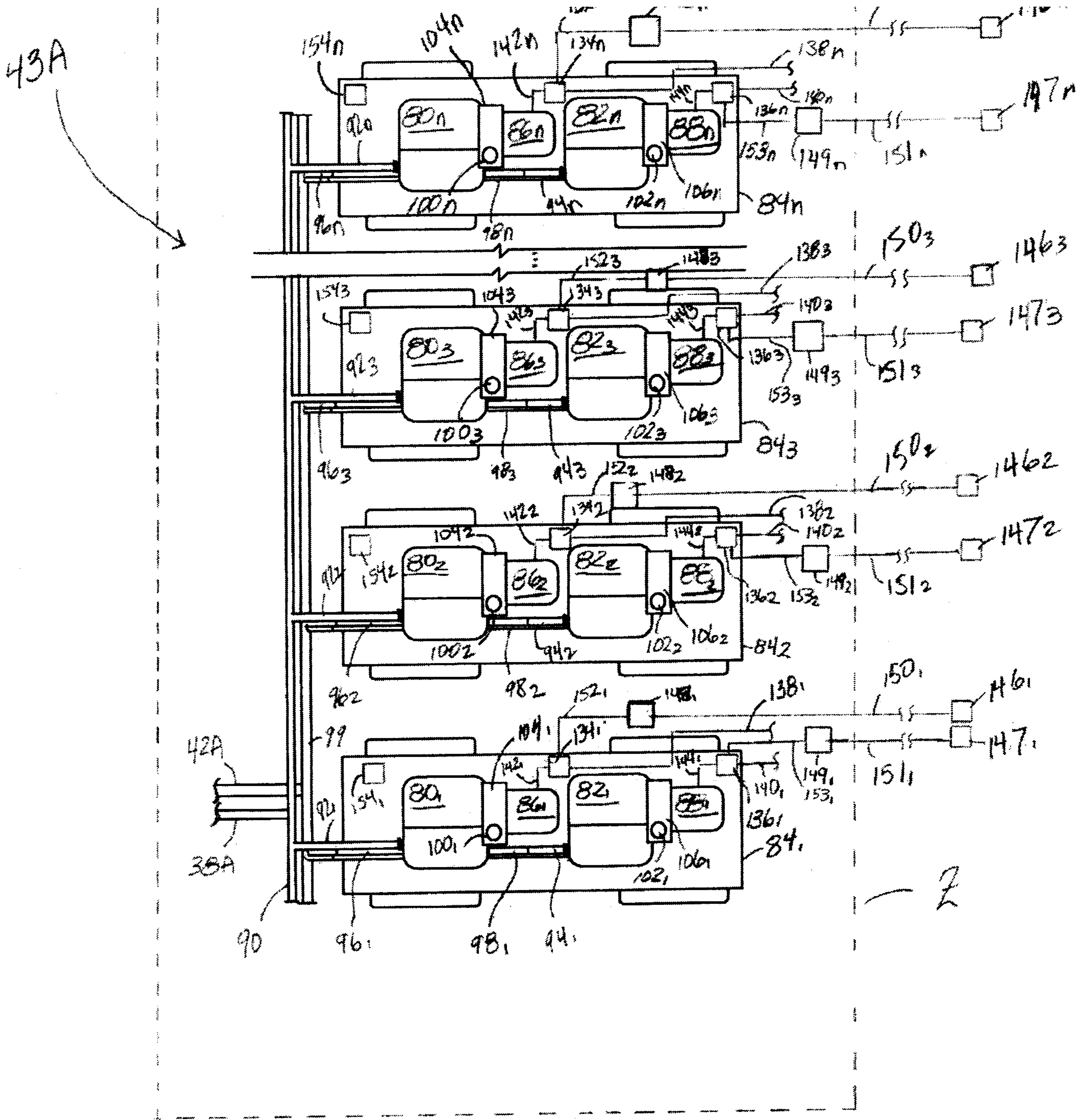

FIG. 2

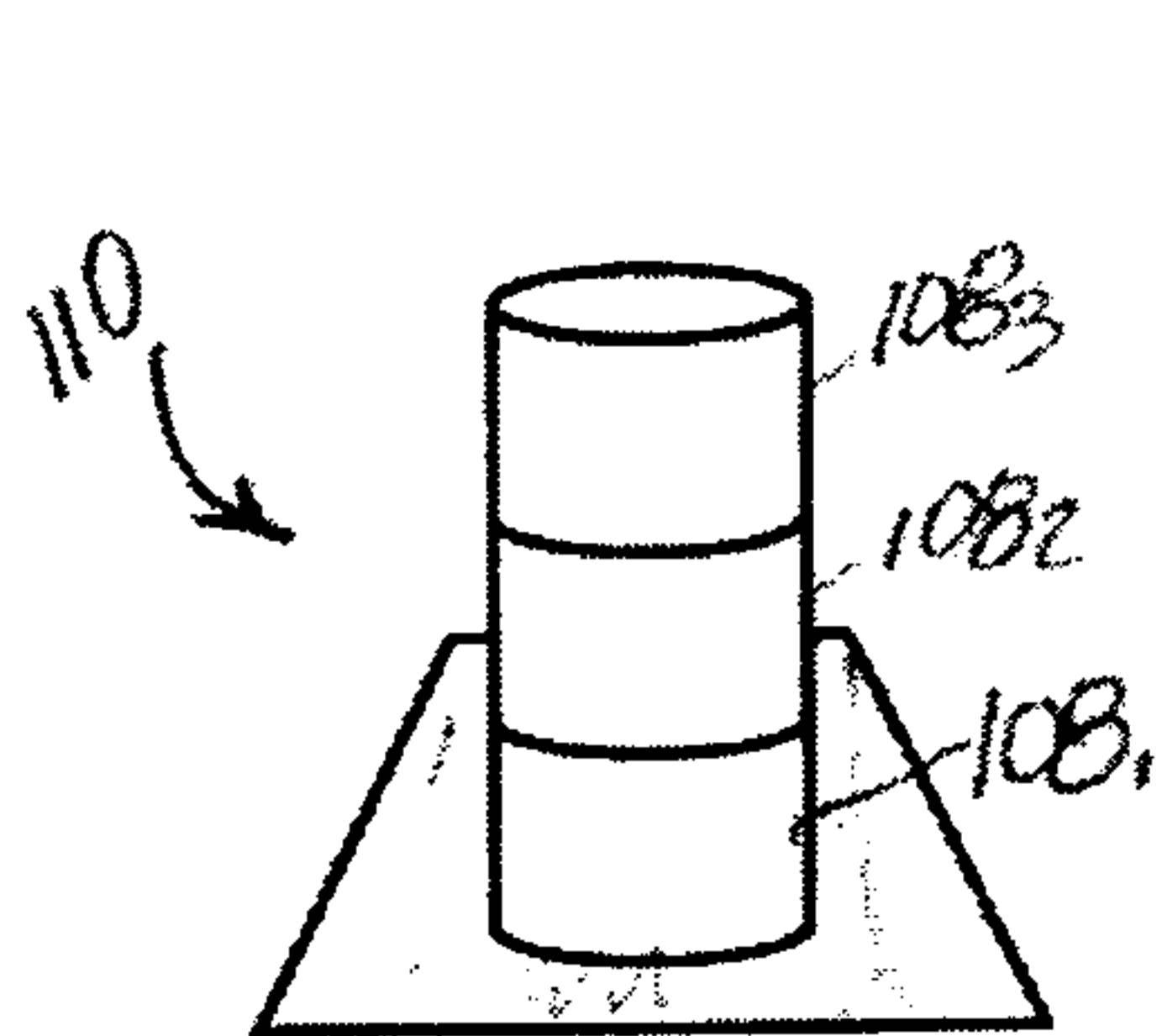
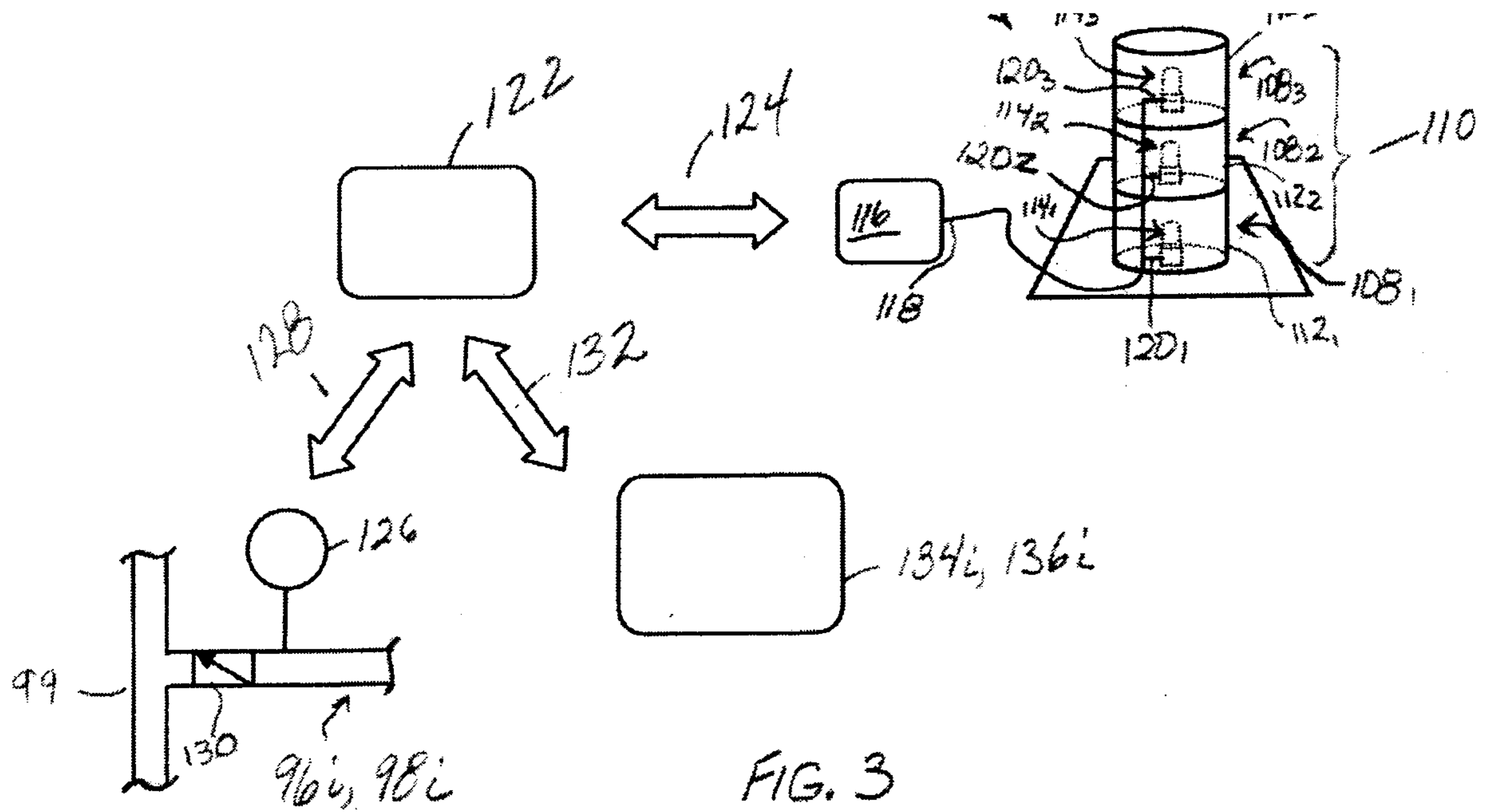

FIG. 4A

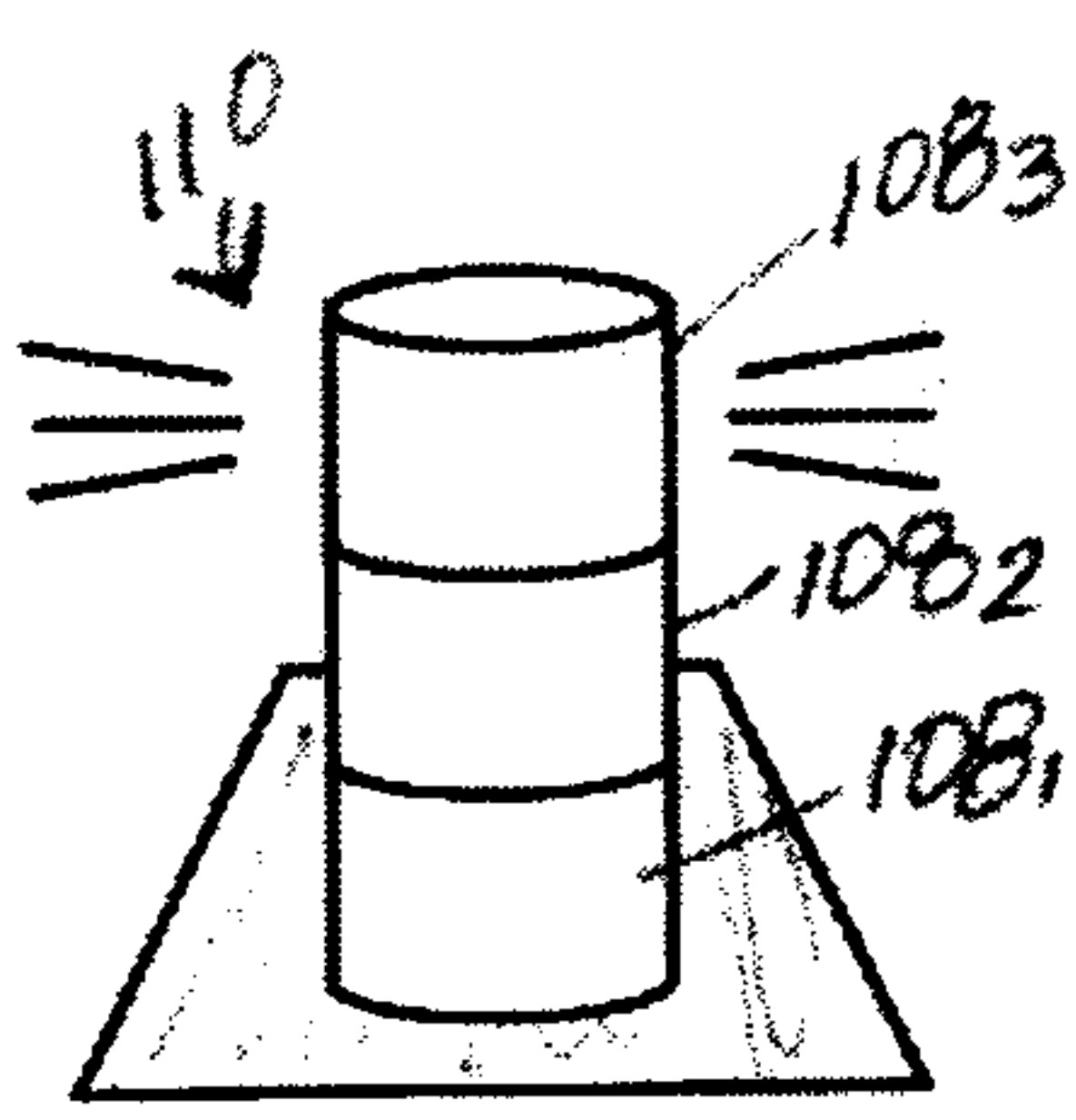

FIG. 4B

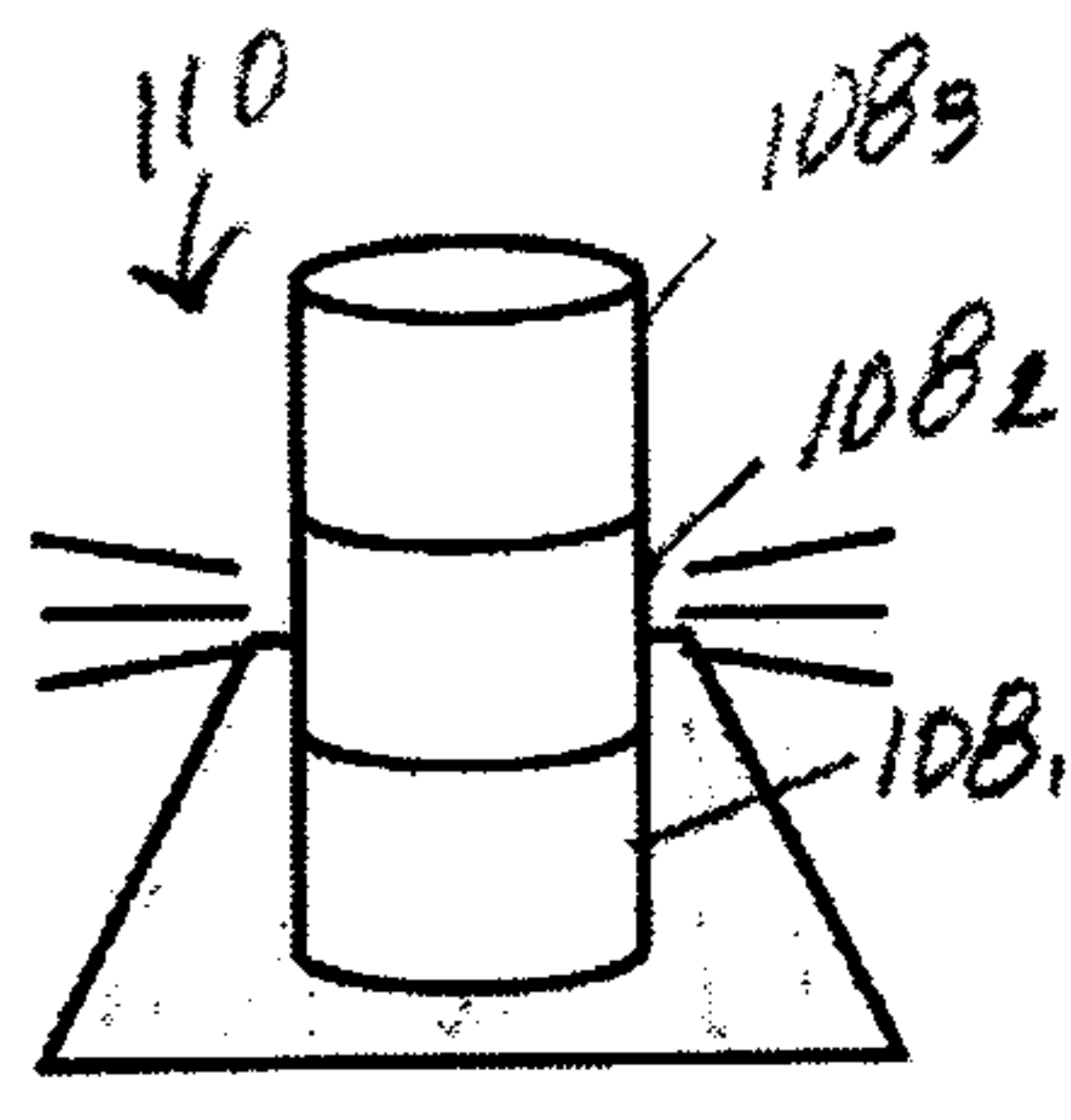

FIG. 4C

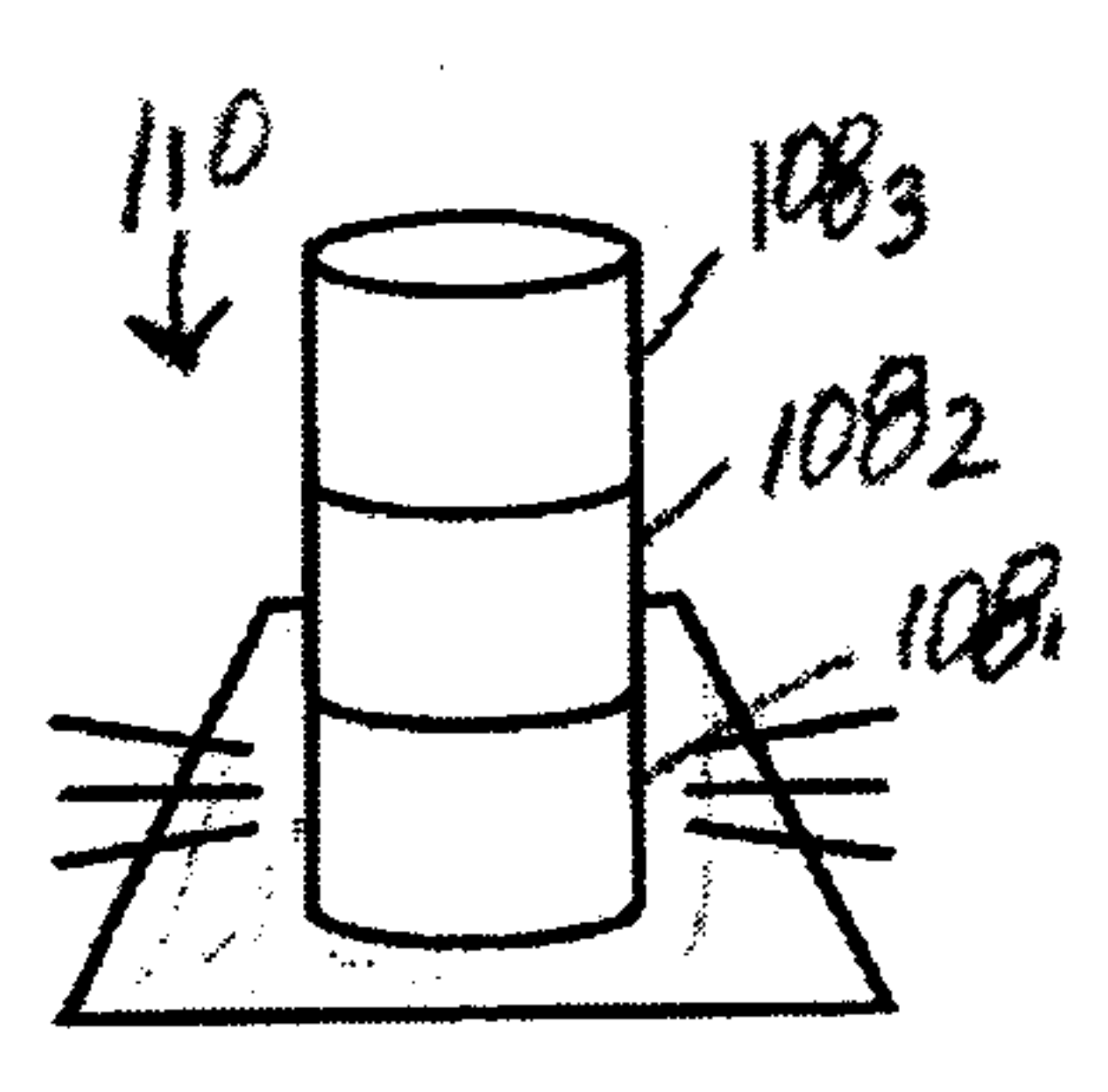

FIG. 4D

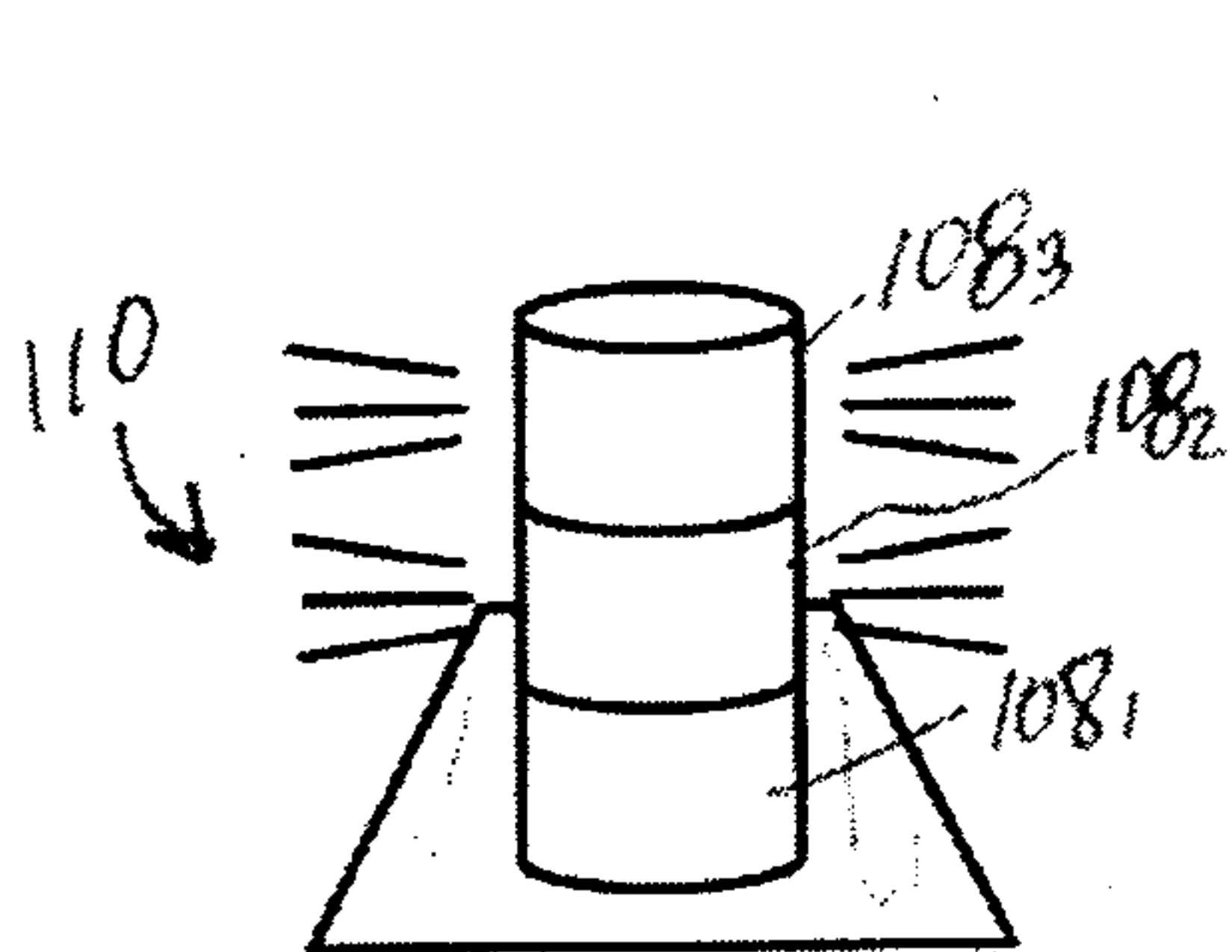

FIG. 4E

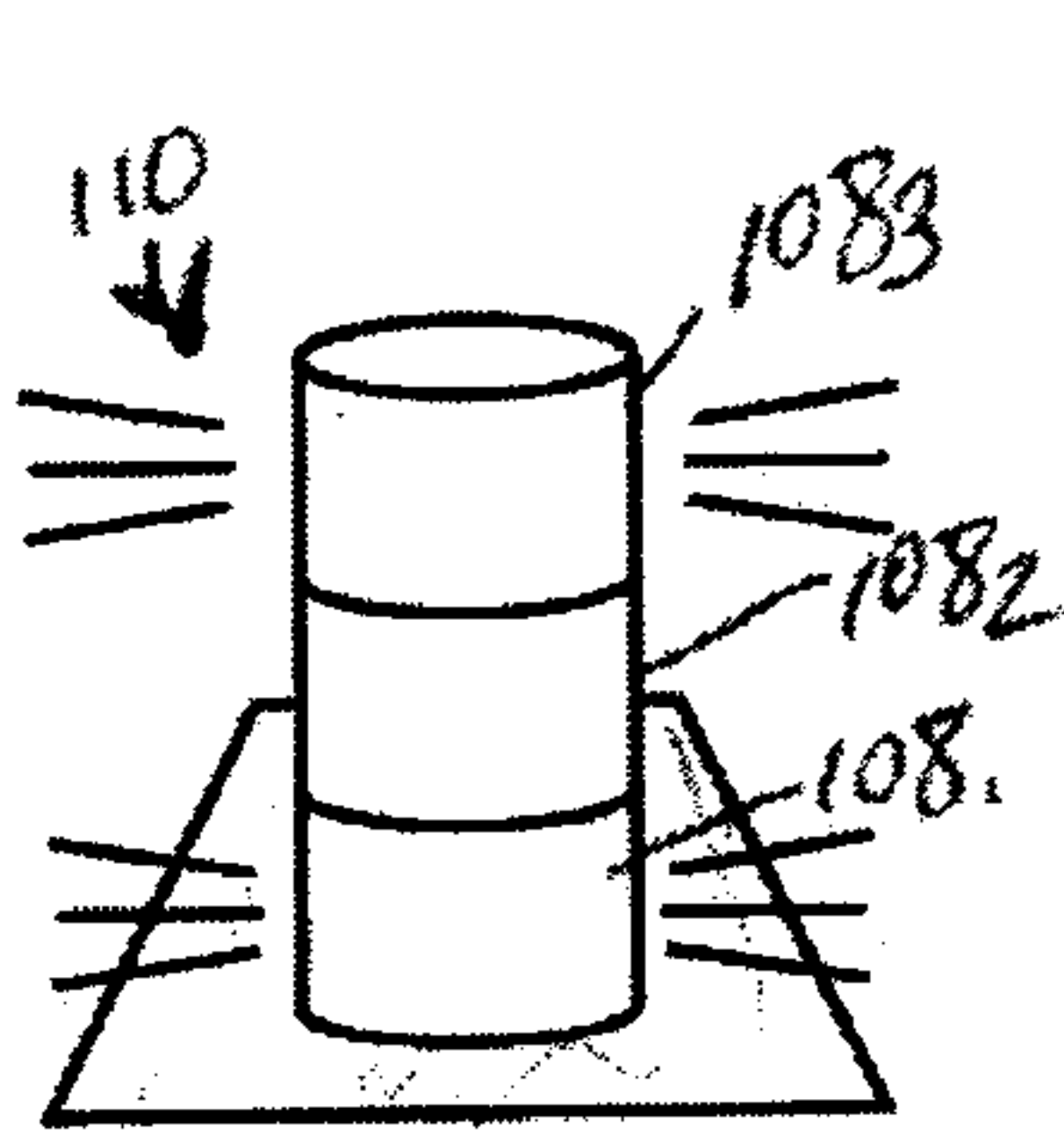

FIG. 4F

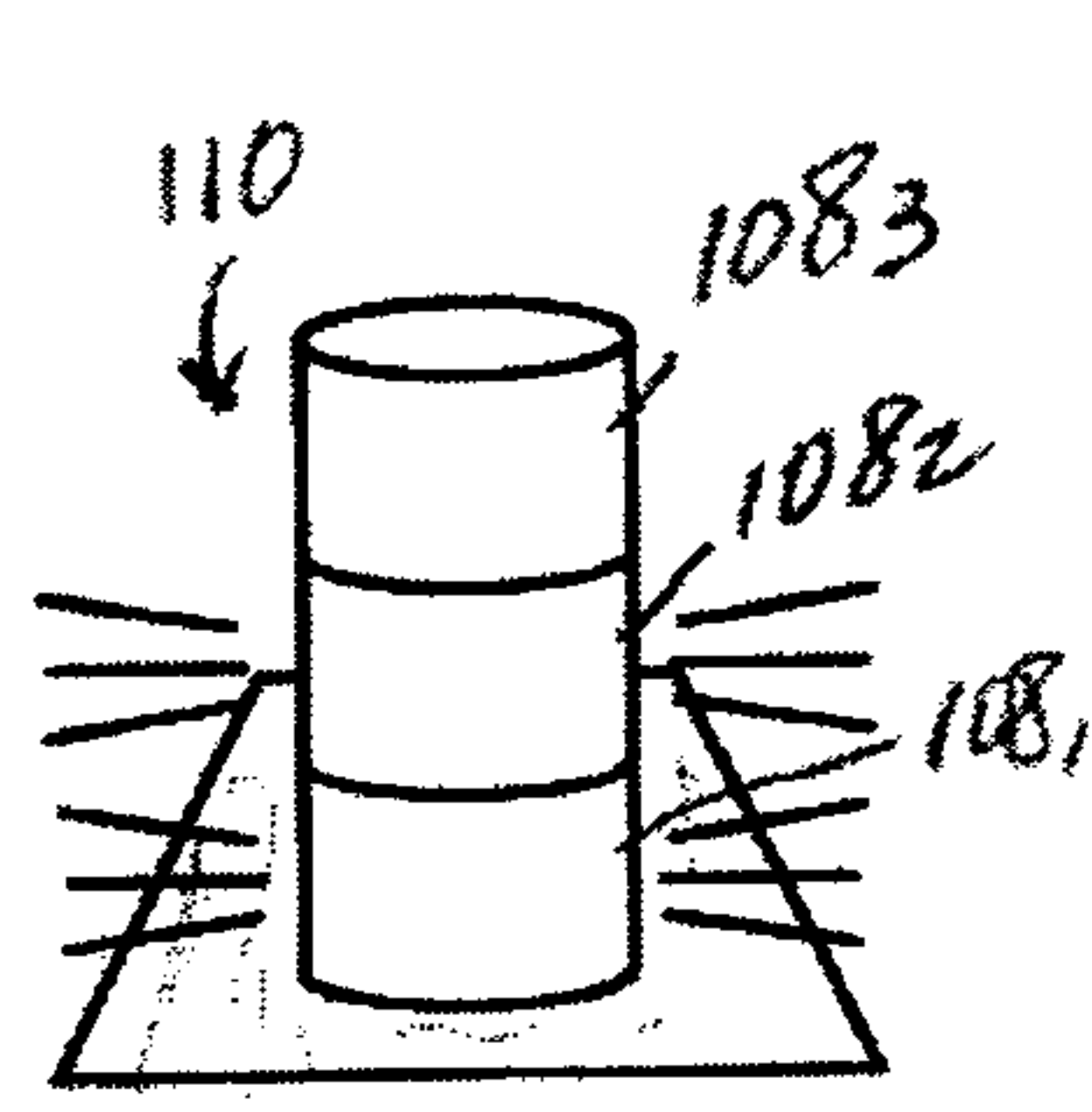

FIG. 4G

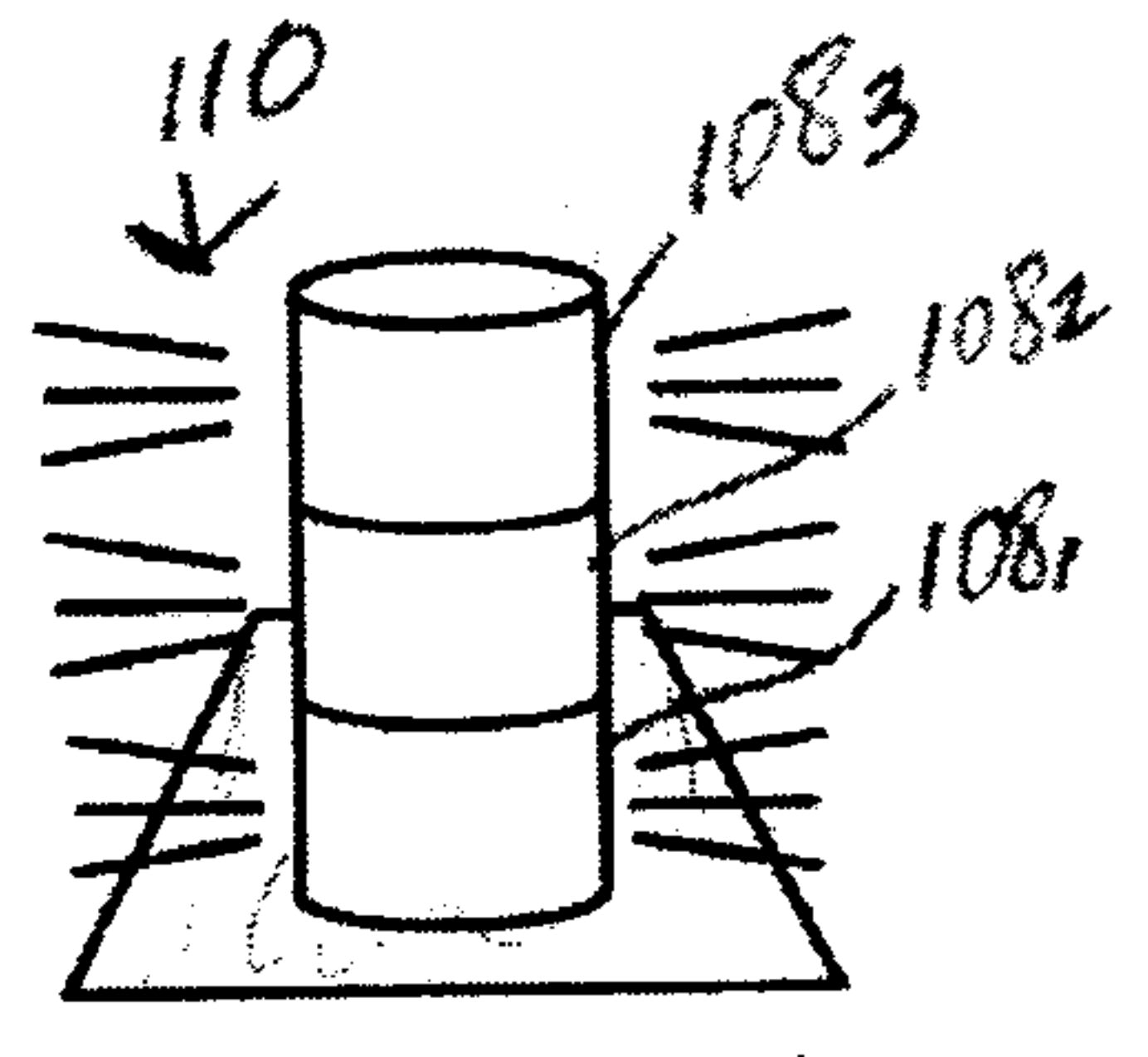

FIG. 4H

