

May 9, 1933.

A. D. EITZEN

1,907,761

WINDING MECHANISM FOR STOCK QUOTATION PROJECTING MACHINES

Filed Feb. 8, 1929

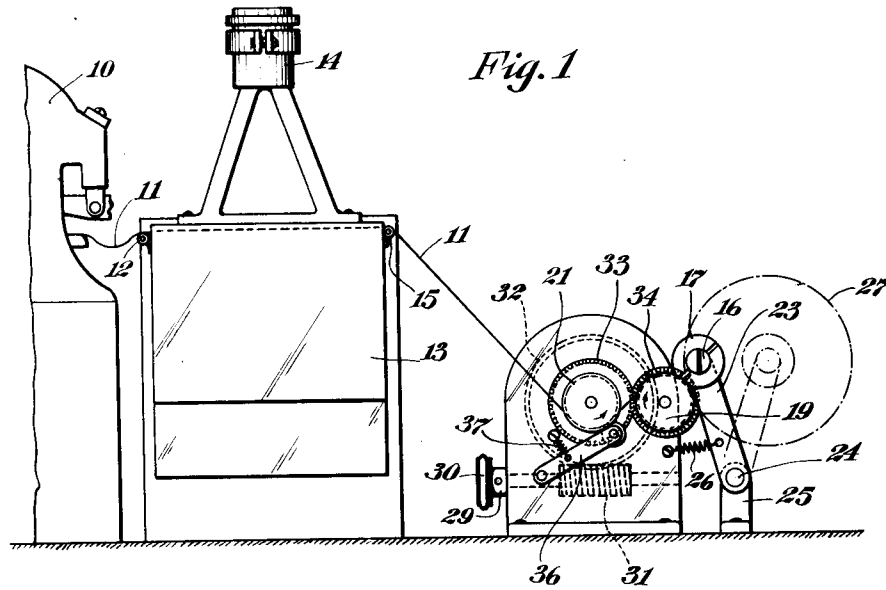

Fig. 1

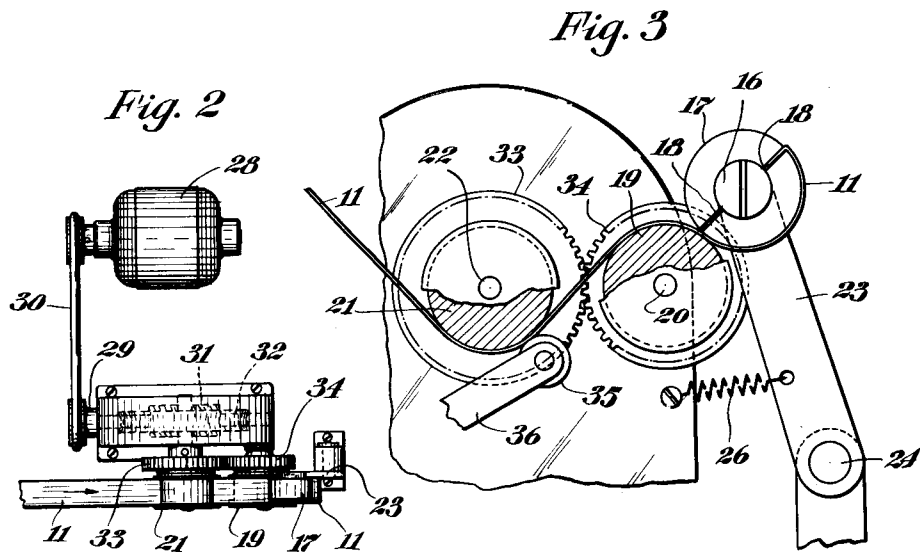

Fig. 2

Fig. 3

INVENTOR  
*August D. Eitzen,*  
BY *Gustav Drew*  
ATTORNEY

# UNITED STATES PATENT OFFICE

AUGUST D. EITZEN, OF NEW YORK, N. Y., ASSIGNOR TO NEWS PROJECTION CORPORATION, OF NEW YORK, N. Y., A CORPORATION OF NEW YORK

## WINDING MECHANISM FOR STOCK QUOTATION PROJECTING MACHINES

Application filed February 8, 1929. Serial No. 338,345.

My present invention relates generally to winding mechanism, and has particular reference to the tape-winding mechanism of a stock quotation projecting machine.

5 In a projecting machine of the character to which my invention relates, a stock ticker is adapted to discharge ticker tape in a substantially continuous manner as the same is marked; and a projecting device is so arranged that the tape may be guided there-  
10 through to permit projection of successive areas thereof. As the tape leaves the projecting device, it is necessary to rewind the same so that the formation and accumulation of a  
15 mass of loose tape may be avoided.

Where the tape is wound into a spiral roll by rotating a mandrel or spindle upon which the roll is formed, it is necessary to provide means for either driving such mandrel at  
20 various rates of angular velocity or for permitting slippage to take place as the diameter of the spiral roll of tape increases.

An object of my present invention is to provide a winding mechanism which operates in  
25 such a manner as to obviate any necessity for such variable driving or for slippage. A more particular object is to provide a winding mechanism wherein the spiral roll is continuously rotated by means which bears or en-  
30 gages upon the periphery thereof, such means being thereby enabled to operate at a substantially constant rate of lineal speed, and the winding being thus accomplished in a uniform and efficient manner regardless of the  
35 particular diameter of the spiral roll of tape at any particular time.

Another object of my present invention is to provide efficient, compact, and simple means for maintaining the tape in a taut condition as the same is fed onto the spiral roll.

It is a general object of my invention to provide a device wherein the means for drawing the tape through the projecting device  
45 and for thereupon winding the tape into a spiral roll is compactly arranged in an extremely simple manner in association with a suitable source of power, such as a motor; and wherein the tape is maintained taut and wound in the manner above mentioned.

50 A particular feature of my invention re-

sides in the provision of a mandrel upon which the spiral roll of tape is to be formed, which mandrel is mounted in an adjustable manner to permit suitable movement or yield-  
55 ing to take place under the increase of spiral roll diameter.

Another feature resides in the provision of a friction roller for simultaneously guiding the tape tangentially onto the spiral roll and rotating the latter by engagement with the  
60 periphery thereof.

A further feature lies in providing a friction roller whose primary function is to draw the tape through the projecting device, and to provide means whereby the two friction  
65 rollers mentioned are simultaneously driven in predetermined relationship.

For the attainment of the foregoing objects and such other objects as may hereinafter appear or be pointed out, I have illustrated  
70 one form of my invention in the accompanying drawing in which—

Figure 1 is an elevational view of a machine constructed in accordance with my present invention, a portion of the stock tick-  
75 er being broken away;

Figure 2 is a plan view of the mechanism shown at the right of Figure 1; and

Figure 3 is a fragmentary enlarged view of a portion of the mechanism shown at the right of Figure 1, this view being taken in  
80 substantially the same direction as Figure 1, with parts broken away for the sake of clearness.

A stock ticker 10 is adapted to discharge  
85 ticker tape 11 in a substantially continuous manner as the same is marked. This tape is guided over a roller 12 or the like into a projecting device 13 wherein a suitable source of  
90 light is arranged to project the markings upwardly through an objective 14 or its equivalent.

As the tape 11 leaves the projecting device by passage over a roller 15 or the like it is directed toward the mechanism for drawing the tape through the projecting device 13  
95 and thereupon rewinding the same.

In accordance with one phase of my invention I provide a mandrel which com-  
100 prises the spindle 16 upon which a drum 17

is mounted for free rotation. A pair of radial slots 18 are provided in the drum 17 to permit the tape end to be engaged and held when the spiral roll is initiated.

5 Adapted to bear against the periphery of the spiral roll throughout its formation and development is a friction roller 19 mounted upon a shaft 20. This roller serves at the same time to guide the tape tangentially onto  
10 the spiral roll. Between the roller 19 and the projecting device 13 is a friction roller 21 whose primary function is to draw the tape through and from the projecting device 13. The roller 21 is mounted upon the shaft  
15 22.

Before describing certain other features of my invention I will draw particular attention to Figures 2 and 3, and will point out that the tape 11 is guided around the lower  
20 portion of the roller 21, thence upwardly over the upper portion of the roller 19, and thence tangentially onto the spiral roll initiated upon the mandrel or drum 17. In Figure 3 I have shown the tape as the same is ar-  
25 ranged immediately after its end has been inserted into one of the slots 18.

One of the features of my invention resides in providing means for permitting the mandrel to yield during the increase of di-  
30 ameter of the spiral roll of tape. For this purpose I have mounted the mandrel upon a pivotable arm 23, the lower end of this arm being articulated at 24 to a suitable stationary pedestal or the like 25. This permits  
35 the arm 23 and the mandrel, together with the spiral roll thereon, to move between the full-line and dotted line positions of Figure 1. Yieldable means such as the spring 26  
40 is provided for constantly urging the arm 23 in the direction which forces the mandrel and the spiral roll thereon into engagement with the friction roller 19.

The roller 19 is driven at a continuous and constant angular velocity whereby its pe-  
45 ripheral speed will also be substantially constant. This in turn causes the spiral roll of tape to be rotated at exactly the proper variable angular velocity, so that its peripheral speed will also be constant. The tape is fed  
50 onto the spiral roll tangentially and at a constant lineal speed regardless of the particular size or diameter of the spiral roll. As the latter is formed, the arm 23 yields toward the right as shown in Figure 1, the dot  
55 and dash line 27 illustrating an outline of the spiral roll after its diameter has been substantially increased. It will be noted from Figure 1 that the efficient and contemplated guiding of the tape onto the spiral  
60 roll, and the proper rotation of the latter, is continued and maintained regardless of the fact that the diameter of the roll has increased.

The manner in which I drive the roller 19  
65 at a constant angular velocity is shown most

clearly in Figure 2. A motor 28 is caused to drive a shaft 29 by means of a belt or thong 30. Mounted on the shaft 29 is a worm 31 which meshes with and drives a worm wheel  
70 32 mounted on the shaft 22. A gear 33 carried by the latter shaft behind the roller 21 is adapted to mesh with a similar gear 34 mounted upon the shaft 20. A suitable casing may be provided to enclose most of the  
75 operative parts.

A particular feature of my invention resides in the provision of means for maintaining the tape 11 in a substantially taut condition so that the feeding of the tape onto the spiral roll will be facilitated and the spiral  
80 roll itself will be constantly compact and firm. I accomplish this object by gearing the rollers 21 and 19 in such a manner that the peripheral speed of the roller 19 is slightly greater than the peripheral speed of the  
85 roller 21. In the instant case, I have illustratively shown the rollers 21 and 19 of the same diameter and the gear 34 of slightly less diameter than that of the gear 33.

When the device is operating, the tape is  
90 frictionally engaged by the periphery of the roller 21, an auxiliary roller 35 being carried by a pivoted arm 36 which, under the action of a spring 37 or the like, holds the roller 35 against the roller 21 to grip the tape. The  
95 tension exerted upon the tape by the frictional engagement of the roller 21 causes a slight elongation of the tape during its passage from the projecting device 13 to the roller 21. As soon as the tape leaves the  
100 roller 21 on its way to the roller 19, the tension thereon is somewhat released, and as a result, if the peripheral speed of the roller 19 were the same as that of the roller 21, the tape would slacken between the roller 21 and  
105 the roller 19. Such slack would materially affect the frictional engagement of the roller 19 with the tape and would therefore impair the smooth guiding of the tape onto the spiral roll. By providing for a slight increase of  
110 peripheral speed of the roller 19, with respect to the peripheral speed of the roller 21, the slack which would otherwise be created is taken up in a continuous manner and the tape is maintained taut.  
115

I do not mean to limit myself to the specific details herein illustrated and described except insofar as the prior art may prescribe. For example, the gears 33 and 34 might be driven  
120 by other means than those shown, and they might be of equal diameters. In such an event, the difference in peripheral speed of the rollers might be provided for by enlarging the diameter of the roller 19. Similarly, although I have shown the mandrel mounted  
125 upon a pivotable arm, it is obvious that this mandrel might be mounted in a yieldable manner by other means. Furthermore, it might in certain cases be preferable to fixedly position the axis of the mandrel and allow the  
130

roller 19 to yield along an arc concentric with the shaft 22.

In general, it is obvious that changes in the details herein described and illustrated for the purpose of explaining the nature of my invention may be made by those skilled in the art without departing from the spirit and scope of the invention as expressed in the appended claims. It is therefore intended that these details be interpreted as illustrative, and not in a limiting sense.

Having thus described my invention and illustrated its use, what I claim as new and desire to secure by Letters Patent—

1. In a tape feeding mechanism adapted for use with a stock ticker and a projecting mechanism, the combination with a main tape pulling roller, of a mandrel, an intermediate tape pulling roller, a main shaft for said main tape pulling roller, a countershaft for said intermediate tape pulling roller, a large gear on said main shaft, a smaller gear on said countershaft in mesh with said main gear, means for driving said main shaft thereby to actuate said intermediate tape pulling roller at a faster speed than the speed of said main tape pulling roller, and a pivotally mounted arm at the free end of which said mandrel is journaled, the main roller, intermediate roller and mandrel being disposed on axes adjacent to one another to permit the tape to pass under said main roller, then over said intermediate roller and finally over and onto said mandrel.

2. In a tape feeding mechanism adapted for use with a stock ticker and a projecting mechanism, the combination with a main tape pulling roller, of a mandrel, an intermediate tape pulling roller, a main shaft for said main tape pulling roller, a countershaft for said intermediate tape pulling roller, a large gear on said main shaft, a smaller gear on said countershaft in mesh with said main gear, means for driving said main shaft thereby to actuate said intermediate tape pulling roller at a faster speed than the speed of said main tape pulling roller, a pivotally mounted arm at the free end of which said mandrel is journaled, the main roller, intermediate roller and mandrel being disposed on axes adjacent to one another to permit the tape to pass under said main roller, then over said intermediate roller and finally over and onto said mandrel, and a pressure roller exercising pressure on the underside of the tape adjacent to said intermediate roller, whereby said pressure roller will prevent the pulling tension of said intermediate roller to be transmitted back to said main pulling roller.

3. In a tape feeding mechanism adapted for use with a stock ticker and a projecting mechanism, the combination with a main tape pulling roller, of a mandrel, an intermediate tape pulling roller, a main shaft for said main tape pulling roller, a countershaft for said inter-

mediate tape pulling roller, a large gear on said main shaft, a smaller gear on said countershaft in mesh with said main gear, means for driving said main shaft thereby to actuate said intermediate tape pulling roller at a faster speed than the speed of said main tape pulling roller, a pivotally mounted arm at the free end of which said mandrel is journaled, the main roller, intermediate roller and mandrel being disposed on axes adjacent to one another to permit the tape to pass under said main roller, then over said intermediate roller and finally over and onto said mandrel, a pressure roller exercising pressure on the underside of the tape adjacent to said intermediate roller, and a spring connected to said arm to press said mandrel into driving engagement with said intermediate roller whereby said pressure roller will cooperate with said intermediate tape pulling roller to prevent the rewinding effect of said mandrel being transmitted back to said main tape pulling roller.

AUGUST D. EITZEN.

70

75

80

85

90

95

100

105

110

115

120

125

130