

No. 724,033.

PATENTED MAR. 31, 1903.

F. L. NICOULIN.  
DUMP WAGON.

APPLICATION FILED JAN. 31, 1903.

NO MODEL.

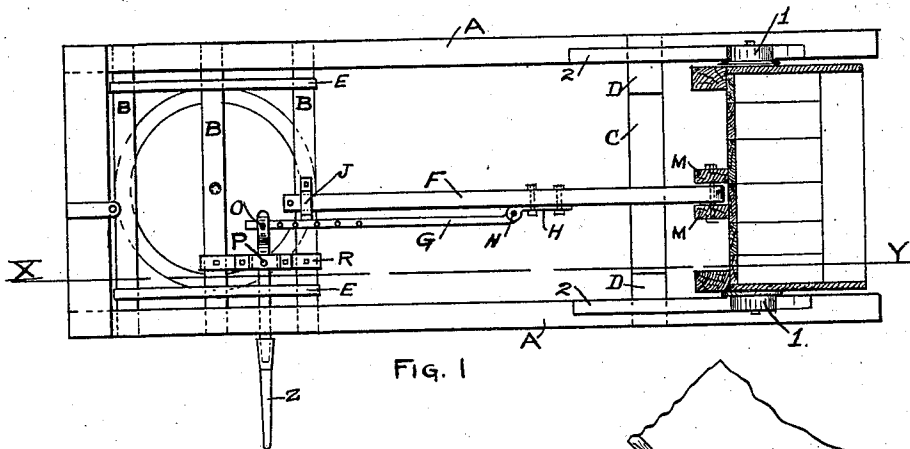

Fig. 1

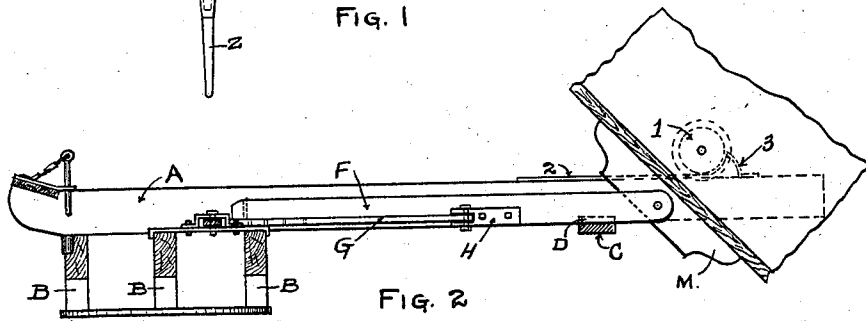

Fig. 2

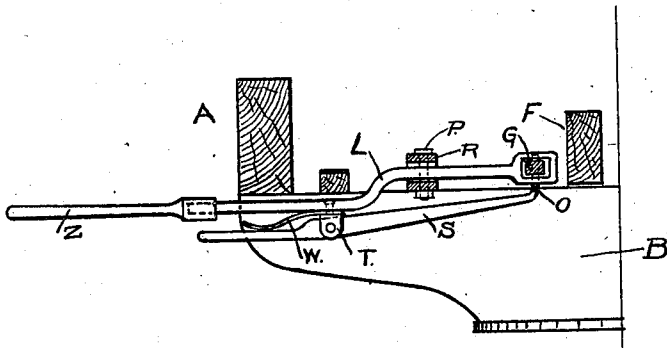

Fig. 3.

WITNESSES.  
Chas. F. Rockwood.  
Ray N. Dolfinger

Frank Louis Nicoulin  
INVENTOR  
BY Pierce Butler  
ATTORNEY.

# UNITED STATES PATENT OFFICE.

FRANK LOUIS NICOULIN, OF LOUISVILLE, KENTUCKY.

## DUMP-WAGON.

SPECIFICATION forming part of Letters Patent No. 724,033, dated March 31, 1903.

Application filed January 31, 1903. Serial No. 141,337. (No model.)

*To all whom it may concern:*

Be it known that I, FRANK LOUIS NICOULIN, a citizen of the United States, residing at Louisville, in the county of Jefferson and State of Kentucky, have invented a new and useful Improvement in Dump-Wagons, of which the following is a specification.

My invention relates to that class of dump-wagons in which the bed or body of the wagon slides upon the gear-sills of a wagon to a desired position before being tilted or dumped, and the essential feature of the invention is the mechanism for sliding or moving the wagon-body illustrated in the accompanying drawings, in which—

Figure 1 is a plan view of the gear-frame of a dump-wagon, showing a sectional view of the body in its inverted or dumping position. Fig. 2 is a longitudinal section of the gear-frame on the line  $xy$  of Fig. 1. Fig. 3 is a half cross-section showing a detailed view of the operating-lever.

Similar characters refer to similar parts in all views.

A represents the side sills of the gear-frame.

B represents the bolsters supporting the gear-sills and carrying the front-truck bearing or "fifth-wheel."

C is the cross-beam, to which the side sills A are fastened near their rear end and upon which are fastened the bearing-blocks D.

Parallel to the side sills and fastened to the upper side of the bolsters B are slide-bars E, upon which the forward end of the body rests when not tilted and upon which the forward end of the body slides previous to the dumping operation.

F is the connecting-bar of my mechanism, one end of which is pivotally fastened to blocks M, rigidly connected to the under side of the floor of the wagon-body, and the forward end of which passes through the guide J on the back bolster B.

Attached to the connecting-bar F is the hinge-strap H, with its hinge-pin N, which passes through an eye in the rear end of the push-bar G. This push-bar G is provided with holes at suitable distances apart into which the pin O of the latch-bar S may be made to enter when desired.

P is a bolt passing through the lever L and

the fulcrum-frame R and is the fulcrum of the lever L.

S is the latch-bar, provided with a pin O at one end and pivotally attached to the lever L by means of the jaws T and pin V and held in a desired position by means of the spring W.

Z is a removable extension-bar having a socket at one end to fit a suitable shank on the outer end of the lever L, by means of which the available length of the lever L may be made as desired.

Following is a description of the operation of my invention: My invention relates to that class of dump-wagons in which the body of the wagon must be moved a determined distance toward the rear of the frame before being tilted or swung backward for the purpose of dumping the load. To produce this backward movement of the body of the wagon in an efficient manner is the object of my invention and is accomplished by the following method: The body of the wagon, with its load, being in its loaded position, with the forward end resting on the guides E and the rear end resting on the blocks D, the extension-bar Z of the lever is applied to the outer end of the lever L and the pin O made to engage with a suitable hole in the push-bar G. The outer end of the lever is then moved toward the front end of the wagon, moving about the pin P as a fulcrum and producing a backward movement of the push-bar G, which movement is communicated to the body of the wagon through the connecting-bar F and the body moved backward as far as permitted by the movement of the lever, when the pin O is released from the first position and the outward end of the lever moved toward the back end of the wagon and the pin O made to engage with another hole in the push-bar G and the operation repeated until the body of the wagon has been moved backward sufficiently to allow it to be tilted upon the axes of the wheels 1 into its dumping position. These wheels 1 serve to carry the weight of the body after it has left the blocks D, and they roll upon a metal plate 2 on the top side of the gear-sills A, the rear end of the plate 2 being bent upward, as at 3, to form a stop. After the load has been emptied from the body it is elevated to its horizontal position and moved

forward to its normal position relative to the frame by a repetition of the movements above described, but in reverse order.

Having described my invention, what I  
5 claim as new, and desire to secure by Letters Patent, is—

In a dump-wagon, the mechanism for moving the body of the wagon, consisting of a connecting-bar pivotally connected to the body  
10 of the wagon, a lever pivotally connected to the gear-frame of the wagon, a link-bar unit-

ing one end of the lever to the connecting-bar, and having holes suitably placed to receive a movable pin in the lever, operated by a secondary latch-lever; an extension-bar fitting the outer end of the main lever, all substantially as shown and described. 15

FRANK LOUIS NICOULIN.

Witnesses:

TOM. DICKINSON,  
M. W. BEARD.