



(86) Date de dépôt PCT/PCT Filing Date: 2008/12/30
 (87) Date publication PCT/PCT Publication Date: 2009/07/09
 (85) Entrée phase nationale/National Entry: 2010/06/28
 (86) N° demande PCT/PCT Application No.: US 2008/088581
 (87) N° publication PCT/PCT Publication No.: 2009/086549
 (30) Priorité/Priority: 2007/12/31 (US61/018,405)

(51) Cl.Int./Int.Cl. *A61F 5/00* (2006.01),
A61M 29/02 (2006.01)

(71) Demandeur/Applicant:
BAROSENSE, INC., US

(72) Inventeurs/Inventors:
COLE, DAVID, US;
CREWS, SAMUEL T., US;
SWOPE, BRETTON, US;
SMITH, ANDREW, US;
LUNSFORD, JOHN, US;
BALBIERZ, DANIEL J., US

(74) Agent: GOWLING LAFLEUR HENDERSON LLP

(54) Titre : SYSTEMES D'ELEMENTS OCCUPANT L'ESPACE GASTRIQUE ET PROCEDES D'UTILISATION
 (54) Title: GASTRIC SPACE OCCUPIER SYSTEMS AND METHODS OF USE

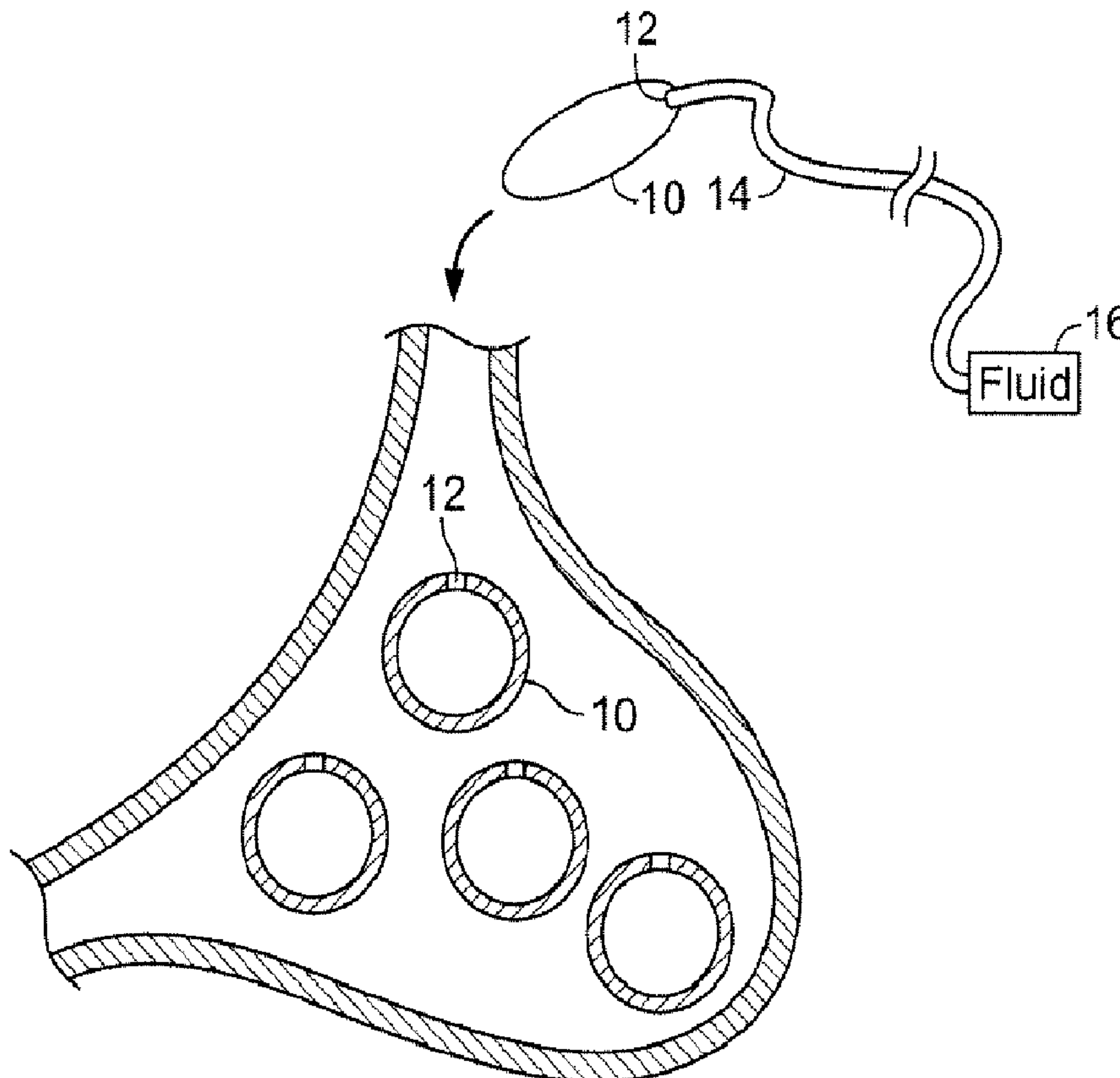

FIG. 1

(57) **Abrégé/Abstract:**

Systems for controlling obesity utilize a number of space occupiers positioned in the stomach to reduce the effective volume of the stomach. Such arrangements provides sufficient stomach volume consumption to induce weight loss, but enable use of space

(57) **Abrégé(suite)/Abstract(continued):**

occupiers that are proportioned to minimize the threat of obstruction even if they should migrate into the intestine. In general, numerous small volume space occupiers are placed in the stomach such that the total volume equals or exceeds the single volume of prior art single unit space occupiers. However, each individual space occupier is proportioned so that it will pass without obstruction if it moves into the intestine.

(12) INTERNATIONAL APPLICATION PUBLISHED UNDER THE PATENT COOPERATION TREATY (PCT)

(19) World Intellectual Property Organization
International Bureau(43) International Publication Date
9 July 2009 (09.07.2009)

PCT

(10) International Publication Number
WO 2009/086549 A1

(51) International Patent Classification:

A61F 5/00 (2006.01)

(21) International Application Number:

PCT/US2008/088581

(22) International Filing Date:

30 December 2008 (30.12.2008)

(25) Filing Language:

English

(26) Publication Language:

English

(30) Priority Data:

61/018,405 31 December 2007 (31.12.2007) US

(71) Applicant (for all designated States except US):

BAROSENSE INC. [US/US]; 3698-C Haven Avenue,
Redwood City, CA 94063 (US).

(72) Inventors; and

(75) Inventors/Applicants (for US only): COLE, David

[US/US]; 1548 Lago Street, San Mateo, CA 94403 (US).

CREWS, Samuel, T. [US/US]; 104040 Skyline Drive,

Woodside, CA 94062 (US). SWOPE, Bretton [US/US];

24812 Woodfield School Road, Gaithersburg, MD 20882

(US). SMITH, Andrew [US/US]; 2240 Pacific Avenue, #
304, San Francisco, CA 94115 (US). LUNSFORD, John
[US/US]; 123 Leslie Drive, San Carlos, CA 94070 (US).
BALBIERZ, Daniel, J. [US/US]; 973 Cambridge Road,
Redwood City, CA 94061 (US).(74) Agents: MAHONEY, Jacqueline, F. et al.; King & Spalding,
P.O. Box 889, Belmont, CA 94002-0889 (US).(81) Designated States (unless otherwise indicated, for every
kind of national protection available): AE, AG, AL, AM,
AO, AT, AU, AZ, BA, BB, BG, BH, BR, BW, BY, BZ, CA,
CH, CN, CO, CR, CU, CZ, DE, DK, DM, DO, DZ, EC, EE,
EG, ES, FI, GB, GD, GE, GH, GM, GT, HN, HR, HU, ID,
IL, IN, IS, JP, KE, KG, KM, KN, KP, KR, KZ, LA, LC, LK,
LR, LS, LT, LU, LY, MA, MD, ME, MG, MK, MN, MW,
MX, MY, MZ, NA, NG, NI, NO, NZ, OM, PG, PH, PL, PT,
RO, RS, RU, SC, SD, SE, SG, SK, SL, SM, ST, SV, SY, TJ,
TM, TN, TR, TT, TZ, UA, UG, US, UZ, VC, VN, ZA, ZM,
ZW.(84) Designated States (unless otherwise indicated, for every
kind of regional protection available): ARIPO (BW, GH,

[Continued on next page]

(54) Title: GASTRIC SPACE OCCUPIER SYSTEMS AND METHODS OF USE

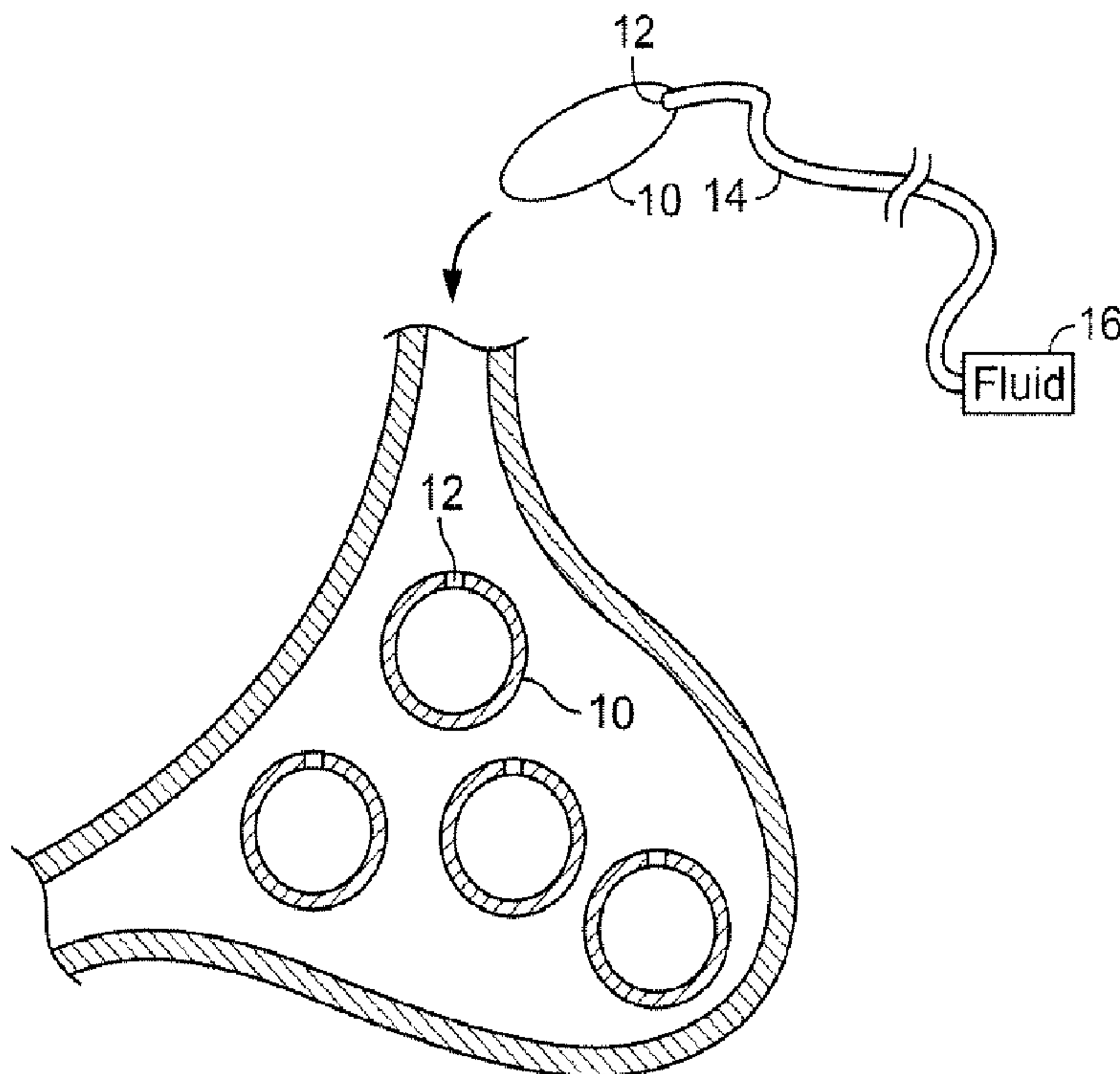

FIG. 1

(57) Abstract: Systems for controlling obesity utilize a number of space occupiers positioned in the stomach to reduce the effective volume of the stomach. Such arrangements provides sufficient stomach volume consumption to induce weight loss, but enable use of space occupiers that are proportioned to minimize the threat of obstruction even if they should migrate into the intestine. In general, numerous small volume space occupiers are placed in the stomach such that the total volume equals or exceeds the single volume of prior art single unit space occupiers. However, each individual space occupier is proportioned so that it will pass without obstruction if it moves into the intestine.

WO 2009/086549 A1

WO 2009/086549 A1



GM, KE, LS, MW, MZ, NA, SD, SL, SZ, TZ, UG, ZM, ZW), Eurasian (AM, AZ, BY, KG, KZ, MD, RU, TJ, TM), European (AT, BE, BG, CH, CY, CZ, DE, DK, EE, ES, FI, FR, GB, GR, HR, HU, IE, IS, IT, LT, LU, LV, MC, MT, NL, NO, PL, PT, RO, SE, SI, SK, TR), OAPI (BF, BJ, CF, CG, CI, CM, GA, GN, GQ, GW, ML, MR, NE, SN, TD, TG).

Published:

— *with international search report*

GASTRIC SPACE OCCUPIER SYSTEMS AND
METHODS OF USE

PRIORITY

[001] This application claims the benefit of U.S. Provisional Application No. 61/018,405, filed December 31, 2007, which is incorporated herein by reference.

TECFINICAL FIELD OF THE INVENTION

[002] The present invention relates generally to the field of implants for inducing weight loss in patients, and specifically to devices and methods for reducing the effective volume of a patient's stomach.

BACKGROUND

[003] Prior art treatments for obesity range from diet and medication to highly invasive surgical procedures. Some of the more successful surgical procedures are the vertical banded gastroplexy or the proximal gastric pouch with a Roux-en-Y anastomosis. However, known complications are present with each of these procedures. More successful and less invasive options are desired.

[004] A less invasive prior art treatment for obesity includes implantation of a gastric space occupier delivered into the stomach via the esophagus. The space occupier is an obstructive device — it prevents overeating by occupying volume within the stomach. Although implantation of a space occupier is less invasive than other surgical procedures, complications do exist. In particular, because space occupiers are typically fluid filled balloons, rupture of balloons can and does occur. A punctured balloon can migrate into the intestines, potentially causing life-threatening intestinal obstruction. Some prior systems attempt to avoid the risk of migration by anchoring space occupiers within the stomach, but these systems tend to nevertheless detach from the stomach wall, resulting in migration. A space occupier which does not pose the treat of obstruction is highly desirable. However, the size of space occupier necessary for weight loss makes a single unit space occupier design difficult.

[005] Additionally, the stomach is a dynamic organ capable of adapting to changes – including those associated with positioning of a space occupier. Given the adaptive nature of the stomach, space occupiers do not adequately provide for long term weight loss. It would be advantageous to have a system which could

accommodate such adaptations, thus allowing for long term weight loss.

[006] The present application describes space occupier designs that minimize risk of obstruction, as well as methods for using the designs in a manner that addresses stomach adaptations and/or changes to the amount of volume consumption needed for a given patient.

BRIEF DESCRIPTION OF THE DRAWINGS

[007] Fig. 1 schematically shows a cross-section view of a stomach, with a plurality of space occupiers positioned within the stomach;

[008] Fig. 2 is similar to Fig. 1, and shows one of the space occupiers deflated and passing through the intestine;

[009] Fig. 3 is similar to Fig. 1 and illustrates use of a second type of space occupier;

[0010] Fig. 4A is a side elevation view of an alternative to the space occupier of Fig. 3;

[0011] Fig. 4B is a cross-section view taken along the plane designated 4B-4B in Fig. 4A;

[0012] Figs. 5 and 6 are cross-section views of the space occupier of Fig. 4A, in which Fig. 5 shows the space occupier in an insertion position and Fig. 6 shows locking of the space occupier into an expanded position;

[0013] Fig. 7 is a side elevation view of yet another embodiment of a space occupier;

[0014] Fig. 8 is similar to Fig. 1, and illustrates the ability of the space occupier of Fig. 7 to shoot upwardly when it migrates into contact with the pyloric sphincter;

[0015] Figs. 9A and 9B illustrate steps in the manufacture of the space occupier of Fig. 7.

DETAILED DESCRIPTION

[0016] The disclosed embodiments address the shortcomings of prior art space occupier technologies. In preferred modes of use, the disclosed systems utilize a number of space occupiers positioned in the stomach. Such an arrangement provides sufficient stomach volume consumption to induce weight loss, but enables use of space occupiers that are proportioned to minimize the threat of obstruction even if they should migrate into the intestine. In general, numerous small volume space occupiers

are placed in the stomach such that the total volume equals or exceeds the single volume of known space occupiers. However, each individual space occupier is proportioned so that it will pass without obstruction if it moves into the intestine. The devices are capable of being inserted transorally, but once in the stomach the space occupiers are expanded or otherwise changed into a shape or size which prevents migration into the intestinal tract. Because they are smaller than known space occupiers, additional individual units may be introduced into the stomach to increase the rate of weight loss or to accommodate changes in the stomach size.

[0017] The disclosed embodiments are preferably formed using materials such as silicone that are capable of withstanding the acidic environment of the stomach, and they are sufficiently soft and appropriately shaped to be atraumatic to the tissue of the stomach. Numerous embodiments are conceivable, a few of which are shown herein. Fig. 1 shows a first embodiment of a space occupier system in which a number of fluid filled space occupiers 10 are transorally passed into the stomach. Ideally the volume of each individual balloon is between 50 — 200 cc, but preferably between 75 and 125 cc. By placing two or more balloons of this size into the stomach, adequate stomach volume is taken up such that weight loss occurs. In some embodiments, the collective volume occupied by the collection of space occupiers can be 300cc or more (e.g. in a range between approximately 300cc and 700cc).

[0018] Each space occupier has a deflated or compressed position allowing its insertion into the stomach via the esophagus as shown. The system may be provided with instruments that facilitate implantation, such as an overtube positionable in the esophagus (through which the space occupiers are passed), and instruments for advancing the space occupiers through the overtube or directly through the esophagus. Such instruments might include push tools that push the space occupiers through the esophagus or overtube, or graspers or alternative instruments that can be used to carry space occupiers through the esophagus or overtube.

[0019] Once a space occupier is positioned in the stomach, fluid (e.g. liquid, gas, gel) is introduced into the space occupier through a valve 12. In one example, an inflation tube 14 is coupled to the valve prior to introduction of the space occupier into the stomach, and is subsequently detached from the space occupier following inflation. Inflation tube is coupled to a fluid source 16 such as a fluid-filled syringe or canister. The space occupiers are shown as spherical but may be any shape that will resist passage into the digestive tract when filled with fluid, but that will readily pass into the

digestive tract, as shown in Fig. 2, when the fluid is released such as through rupture.

[0020] The number of space occupier units implanted at any given time is selected to give a target stomach volume consumption selected to yield the desired weight loss results. Additional units may be added, or some units removed, during the course of weight loss treatment to increase or decrease the total volume consumption and the corresponding rate of weight loss and/or to respond to adaptive changes in the stomach's volume.

[0021] Fig. 3 illustrates use of an alternate form of space occupier 10a that need not be inflatable but that is positioned in a first streamlined shape 18a for insertion into the stomach and is then manipulated into a different, less streamlined shape 18b that will resist passage into the digestive tract. In this embodiment, the space occupier 10a is an elongate band 20 having a locking feature that joins the ends of the band to form a cylindrical element or oval shaped element. In one configuration, the locking feature includes a tab 22 on one end and a receptacle 24 on the other end for receiving the tab in locking engagement.

[0022] The Fig. 3 embodiment may be constructed to form a wide variety of alternate shapes beyond a cylindrical or oval shape. For example, Fig. 4A shows a modification to the Fig. 3 embodiment in which the ends of band 20a are coupled together to form a space occupier 10b having a triangular shape. Band 20a may have a circular cross-section as shown in Fig. 4B to give the space occupier a smooth exterior surface. Suitable diameters for the band range from 0.25 – 1 inches, or more preferably 0.5 – 0.75 inches.

[0023] As shown in Fig. 5, the band 20a may be formed to include predetermined bend locations 26 formed using, for example, weakened or thinned regions of band material. In the illustrated embodiment, bend locations are formed by forming v-shaped hinges into the band material.

[0024] For implantation, the band is positioned in its linear/streamlined configuration and introduced into the stomach as shown in Fig. 3. Overtubes, pushers, graspers etc may be used to facilitate introduction of the band into the stomach as indicated in connection with the Fig. 1 embodiment.

[0025] Once the band has been passed into the stomach, the ends of the band are brought together to form the band into a shape that will be unable to pass into the intestinal tract (such a shape may be referred to herein as a “non-passable shape”). Various tools or actuators may be used for this purpose. In one example shown in Fig.

5, a tether 28 is coupled to tab 22 and threaded through the receptacle 24 and also through a pusher tube 30. To couple the ends of the band 20a, tether 28 is withdrawn while pusher tube 30 is pushed against the band 20a as shown in Fig. 6, causing the tab 22 to pass into and become engaged in the receptacle 24. The tether 28 and pusher 30 are proportioned such that their proximal ends may be manipulated in this manner from outside the body. If the tab should become disengaged, the band will return to the streamlined shape and thus will be able to pass through the intestinal tract without harm to the patient.

[0026] As with the Fig. 1 embodiment, multiple units of the space occupier 10a, 10b are preferably used at one time to achieve a desired collective volume consumption within the stomach, such as that described in connection with the Fig. 1 embodiment. The number of units placed in the stomach may be decreased or increased as needed to achieve the target weight loss.

[0027] Fig. 7 illustrates yet another embodiment of a gastric space occupier 10c having a shape that inhibits passage of the space occupier into the digestive tract. Space occupier 10c is a tubular balloon. The balloon has inner and outer walls 32a, 32b, and a fluid between the inner and outer walls. A lumen 34 extends longitudinally through the tubular balloon.

[0028] The construction of the space occupier 10c is similar to that of a children's toy known as a "water snake". In particular, the space occupier is configured such that squeezing the outer surface at one end will "squirt" the space occupier away from the point of compression by causing the layer of wall lining the lumen 34 to roll to the outside of the balloon while the layer of wall lining the outer surface of the balloon rolls into the lumen as indicated by arrows in Fig. 7. This feature aids in preventing the device from passing into the digestive tract. In particular, should the device begin to migrate into the digestive tract, its distal-facing end will be compressed or squeezed as it descends into the pyloric antrum and/or abuts the pyloric sphincter. In response to this compression, the device walls will propel the device away from the pyloric sphincter as shown in Fig. 8

[0029] Figs. 9A and 9B illustrate steps of manufacturing the space occupier 10c. Referring to Fig. 9A, a tube 36 having lumen 34 is provided. Tube 36 may have a uniform diameter, and it can be formed of a thin-walled extrusion of silicone, urethane, or other suitable material. The ends 40 of the tube are everted and brought together on the exterior of the tube, thus giving the tube a double-layer wall. Fluid is

introduced into the space 38 between the layers 32a, 32h of the wall. A seal 42 is applied to seal the ends 40 together and to seal the fluid within the space 38. Seal 42 may include a valve, allowing the fluid to be introduced in situ as described with respect to the Fig. 1 embodiment. Alternatively, the seal may be provided without a valve. This embodiment may be used as a single unit, or multiple units may be implanted in the stomach.

[0030] As with previously described embodiments, obesity using the space occupier 10c may involve placing a single space occupier or multiple space occupiers within the stomach to achieve a desired collective volume consumption within the stomach, such as that described in connection with the Fig. 1 embodiment. As with the previous embodiments, the overall and/or rate of weight loss is monitored, and the number of units may be decreased or increased as needed to achieve the target weight loss or rate of weight loss. The space occupiers 10c may be passed through an endogastric overtube or introduced into the stomach by some other means.

[0031] The disclosed space occupiers and associated systems may be provided with instructions for use instructing the user to utilize the space occupiers according to the various steps described herein.

[0032] It should be recognized that a number of variations of the above-identified embodiments will be obvious to one of ordinary skill in the art in view of the foregoing description. Moreover, various features of the disclosed embodiments may be combined in a variety of ways. Accordingly, the invention is not to be limited by those specific embodiments and methods of the present invention shown and described herein. Rather, the scope of the invention is to be defined by the following claims and their equivalents.

[0033] Any and all prior patents and applications referred to herein, including for purposes of priority, are fully incorporated by reference.

We Claim:

1. A gastric space occupier, comprising:
a tubular balloon having a tubular wall comprising an outer tubular layer and an inner layer tubular disposed within the outer tubular layer, the inner and outer tubular layers having a space therebetween, the wall defining an elongate lumen extending through the balloon; and
a fluid in the space between the inner and outer tubular layers.
2. The gastric space occupier of claim 1, wherein the inner and outer tubular layers are slidable relative to one another in opposite directions.
3. The gastric space occupier of claim 2, wherein the inner and outer tubular layers are slidable from a first arrangement in which the inner tubular layer is disposed within the outer tubular layer, and a second arrangement in which the outer tubular layer is disposed within the inner tubular layer.
4. The gastric space occupier of claim 3, wherein the inner and outer tubular layers are moveable between the first and second arrangements in response to radially inward pressure against an outer surface of the tubular balloon.
5. The gastric space occupier of claim 1, wherein the tubular wall is formed of an elongate tube having first and second ends, the first and second ends sealed together to form the tubular inner and outer layers and the space between the inner and outer tubular layers.
6. The gastric space occupier of claim 1, further including a valve fluidly coupled to the space.
7. The gastric space occupier of claim 1, wherein the gastric space occupier includes a plurality of the tubular balloons.

8. A method of treating obesity in a patient, comprising:
placing a tubular balloon into a stomach, the tubular balloon including a tubular wall comprising an outer tubular layer and an inner layer tubular disposed within the outer tubular layer, and a space between the inner and outer tubular layers;
filling the space between the inner and outer tubular layers with a fluid such that the fluid is contained within the tubular wall.
9. The method of claim 8, wherein the method further includes;
in the event the tubular balloon advances from the stomach into contact with walls of a lumen of the stomach or intestine that is sufficiently narrow to impart radially inward pressure against the tubular balloon, allowing the inner and outer tubular layers to slide relative to one another in the opposite directions, causing the tubular balloon to move proximally within the stomach.
10. The method of claim 8, wherein filling the space includes filling the space prior to placing the tubular balloon into the stomach.
11. The method of claim 8, wherein filling the space includes filling the space after placing the tubular balloon into the stomach.
12. The method of claim 8, wherein the method includes placing a plurality of the tubular balloons into the stomach.
13. The method of claim 12, further including monitoring a rate of weight loss by the patient, and removing at least one tubular balloons from the stomach to decrease the rate of weight loss.
14. The method of claim 8, further including monitoring a rate of weight loss by the patient, and placing additional tubular balloons into the stomach to increase the rate of weight loss.

15. The method of claim 8, wherein the tubular balloon reduces the effective volume of the stomach by an amount sufficient to cause the patient to lose weight.

16. A gastric space occupier system comprising:

an elongate member having first and second end portions, the elongate member moveable between a first generally streamlined position in which the elongate member is shaped for passage through the esophagus into the stomach, and a second position in which the elongate member is incapable of passage from the stomach into the intestine; and

a fastener positioned to couple the first and second end portions together to retain the elongate member in the second position.

17. The gastric space occupier system of claim 16, wherein first and second end portions have first and second ends, respectively, and wherein the fastener is positioned to couple the first end to the second end.

18. The gastric space occupier system of claim 17, wherein the elongate member in the second position bounds a central opening.

19. The gastric space occupier system of claim 18, wherein the elongate member in the second position has a generally annular shape.

20. The gastric space occupier system of claim 18, wherein the elongate member in the second position defines a generally triangular shape.

21. The gastric space occupier system of claim 20, wherein the elongate member includes a pair of bend regions, and wherein the elongate member is bendable at the bend regions to move the elongate member from the first position to the second position.

22. The gastric space occupier system of claim 17, further including an element coupled to the first end and slidably coupled to the second end such that application of tension to the element moves the first end towards the second end.

23. The gastric space occupier system of claim 16, further including a plurality of the elongate members independently introducible through the esophagus into the stomach, and each moveable to a second position incapable of passage from the stomach into the intestine.

24. A method of treating obesity in a patient, comprising:
introducing an elongate member in a streamlined first position through an esophagus into a stomach;
moving first and second end portions of the elongate member relatively towards one another to position the elongate member in a second position in which the elongate member is incapable of passage from the stomach into the intestine; and
coupling the first and second end portions together to retain the elongate member in the second position.

25. The method according to claim 23, wherein the method further includes:
placing a plurality of the elongate members in the second position in the stomach.

26. The method according to claim 25, wherein the elongate members reduce the effective volume of the stomach by an amount sufficient to cause the patient to lose weight.

27. A method of treating obesity in a patient using a gastric implant, comprising:
introducing a plurality of gastric balloons within the stomach, each gastric balloon having a volume in the range of approximately 50 – 200 cc, wherein the plurality of gastric balloons reduce the effective volume of the stomach by an amount sufficient to cause the patient to lose weight.

28. The method of claim 27, wherein each gastric balloon has a volume in the range of approximately 75 - 125 cc.

29. The method of claim 27, further including monitoring a rate of weight loss by the patient, and removing at least one gastric balloon from the stomach to decrease the rate of weight loss.

30. The method of claim 27, further including monitoring a rate of weight loss by the patient, and placing additional gastric balloons into the stomach to increase the rate of weight loss.

31. The method of claim 27, wherein the gastric balloons collectively occupy at least approximately 300 cc of stomach volume.

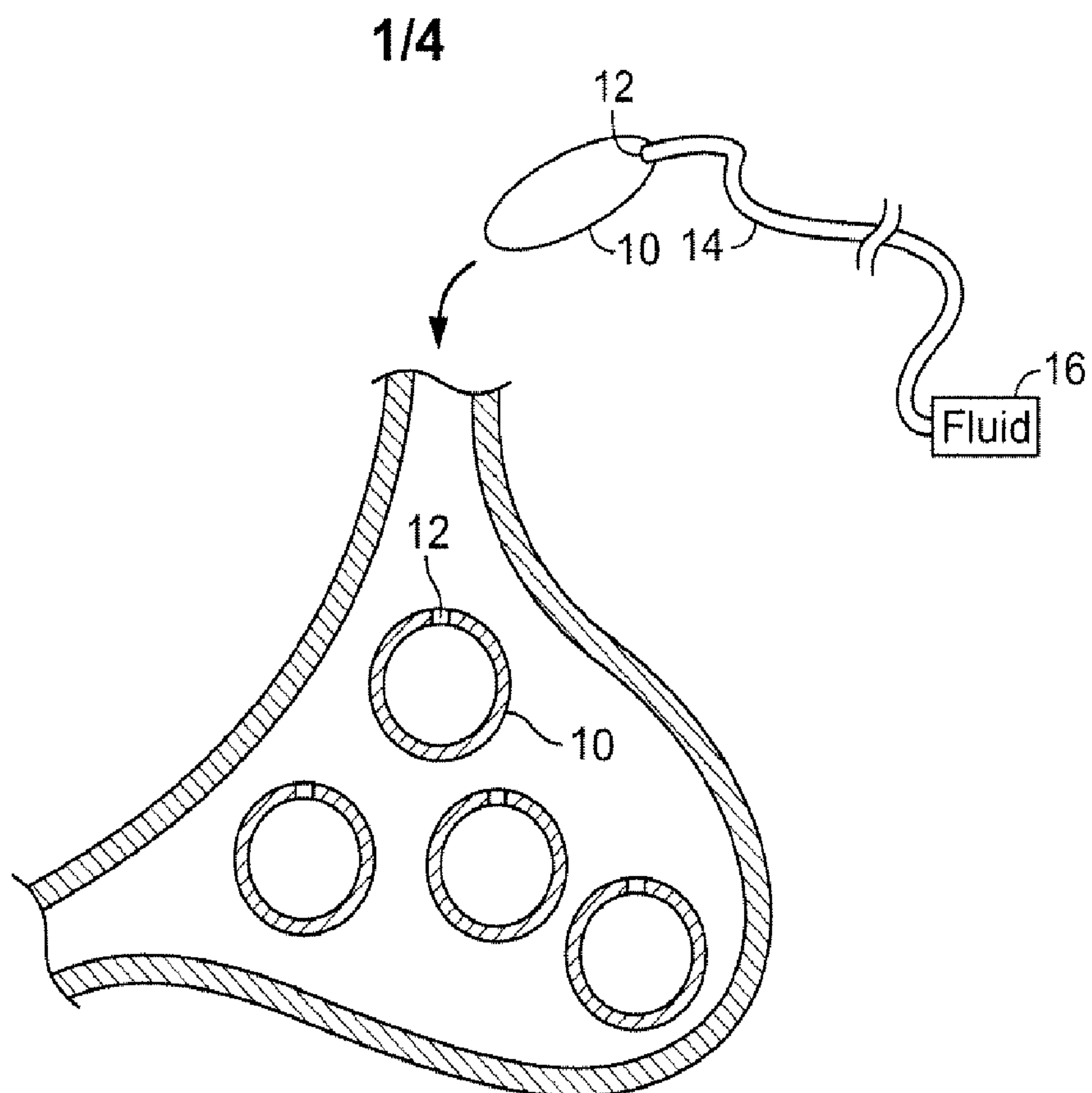

FIG. 1

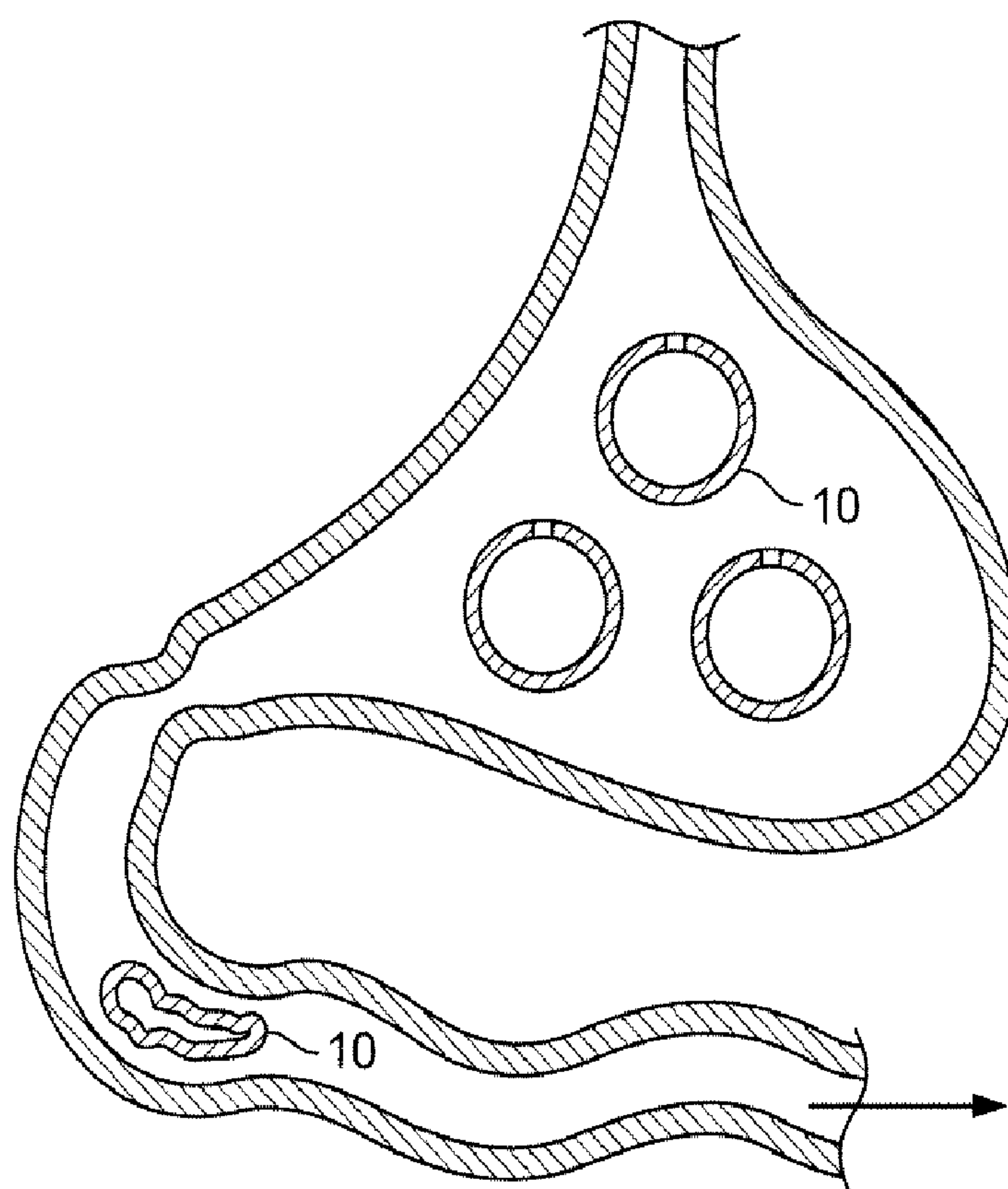

FIG. 2

2/4

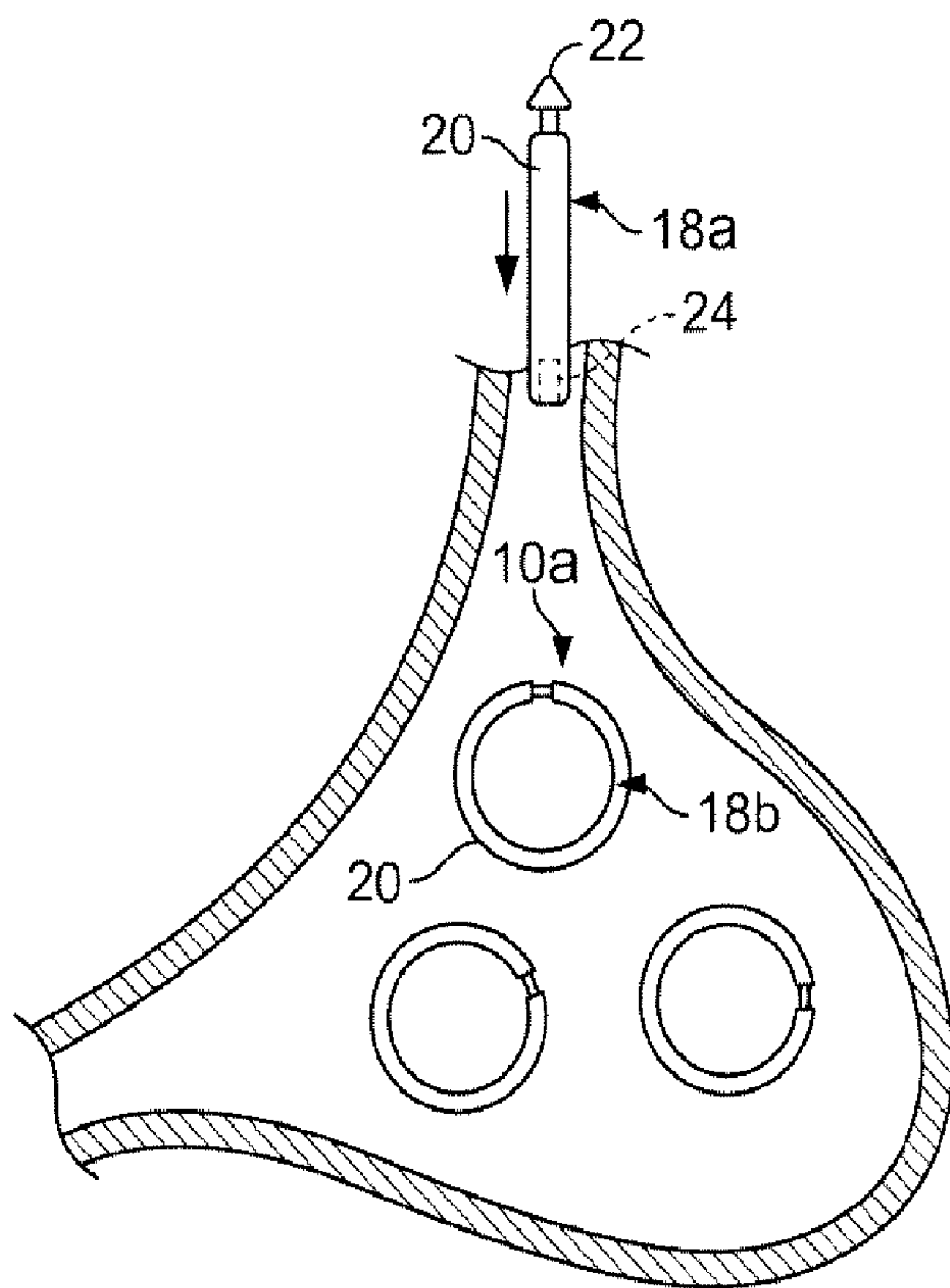

FIG. 3

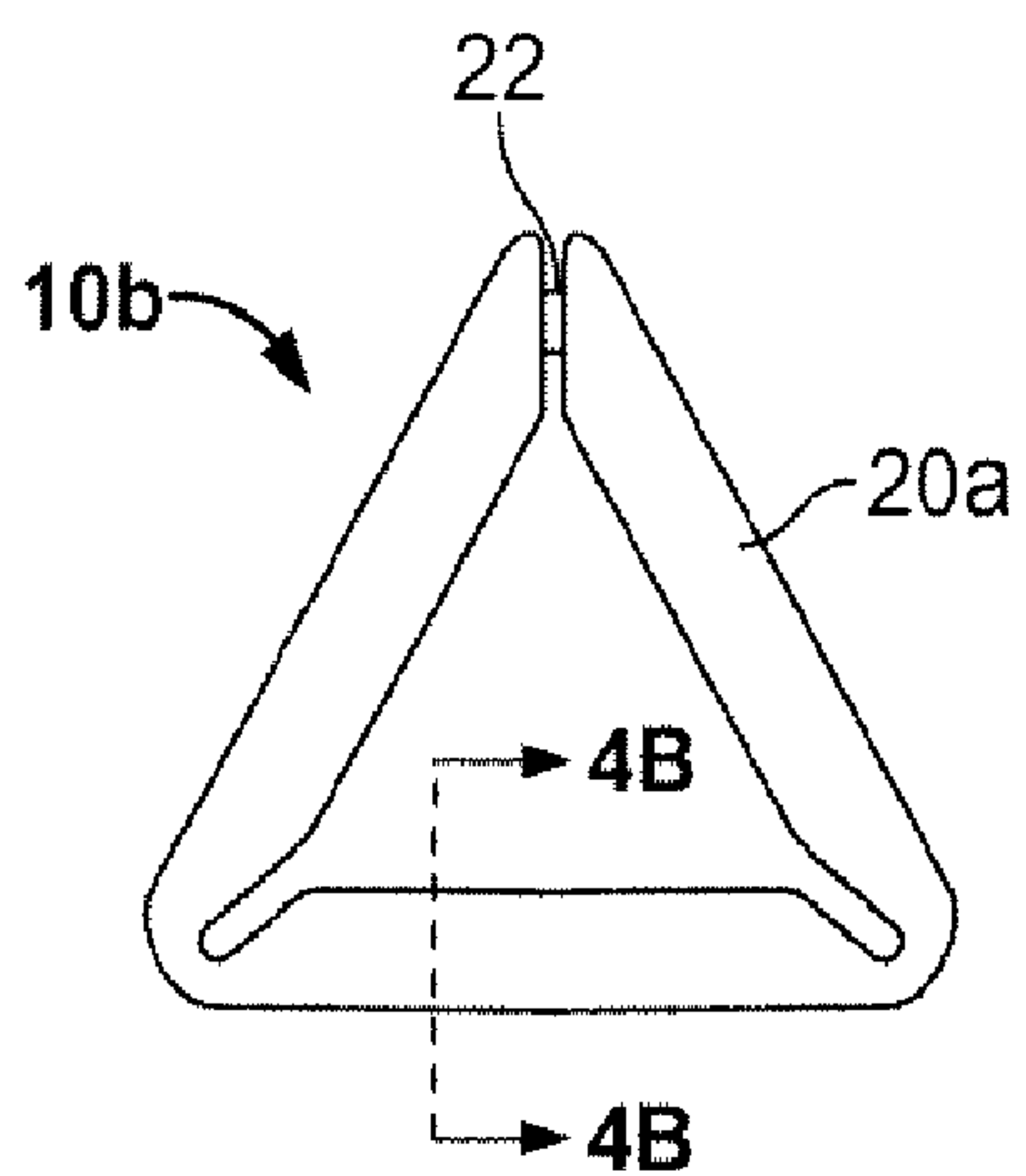

FIG. 4A

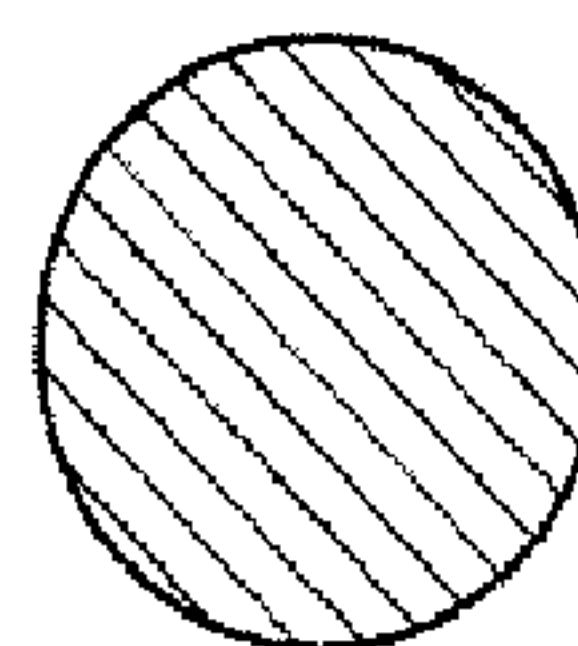

FIG. 4B

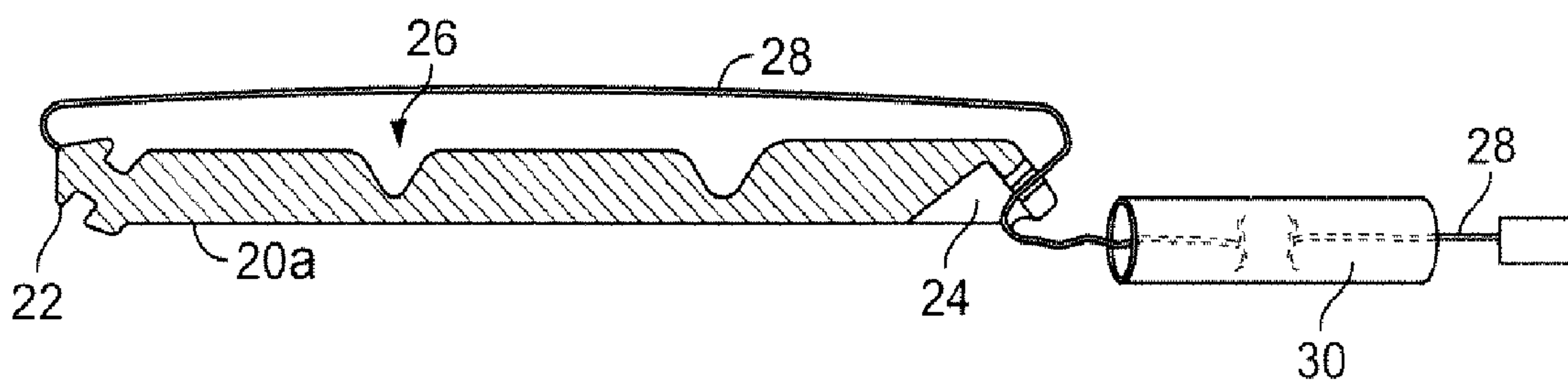

FIG. 5

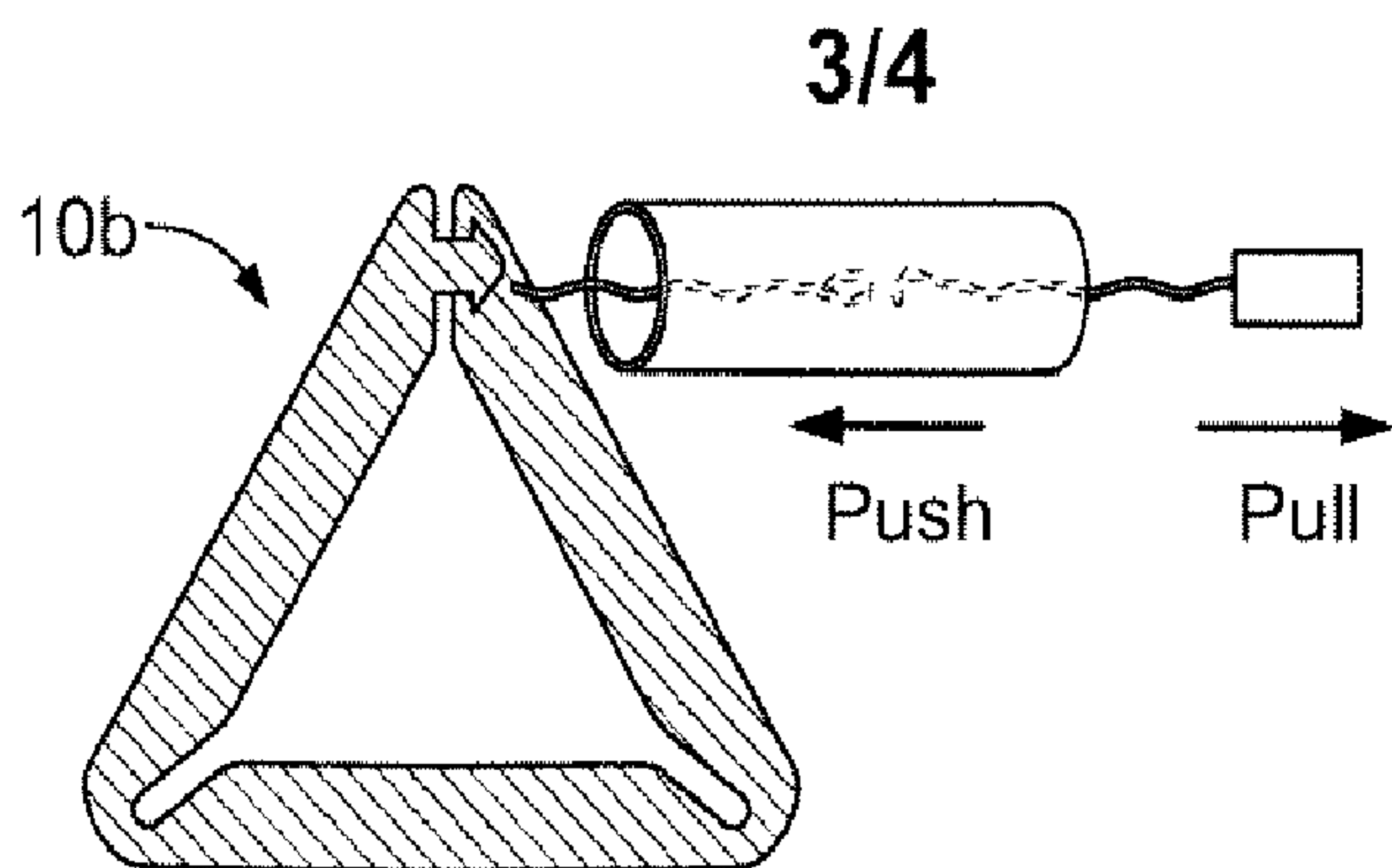

FIG. 6

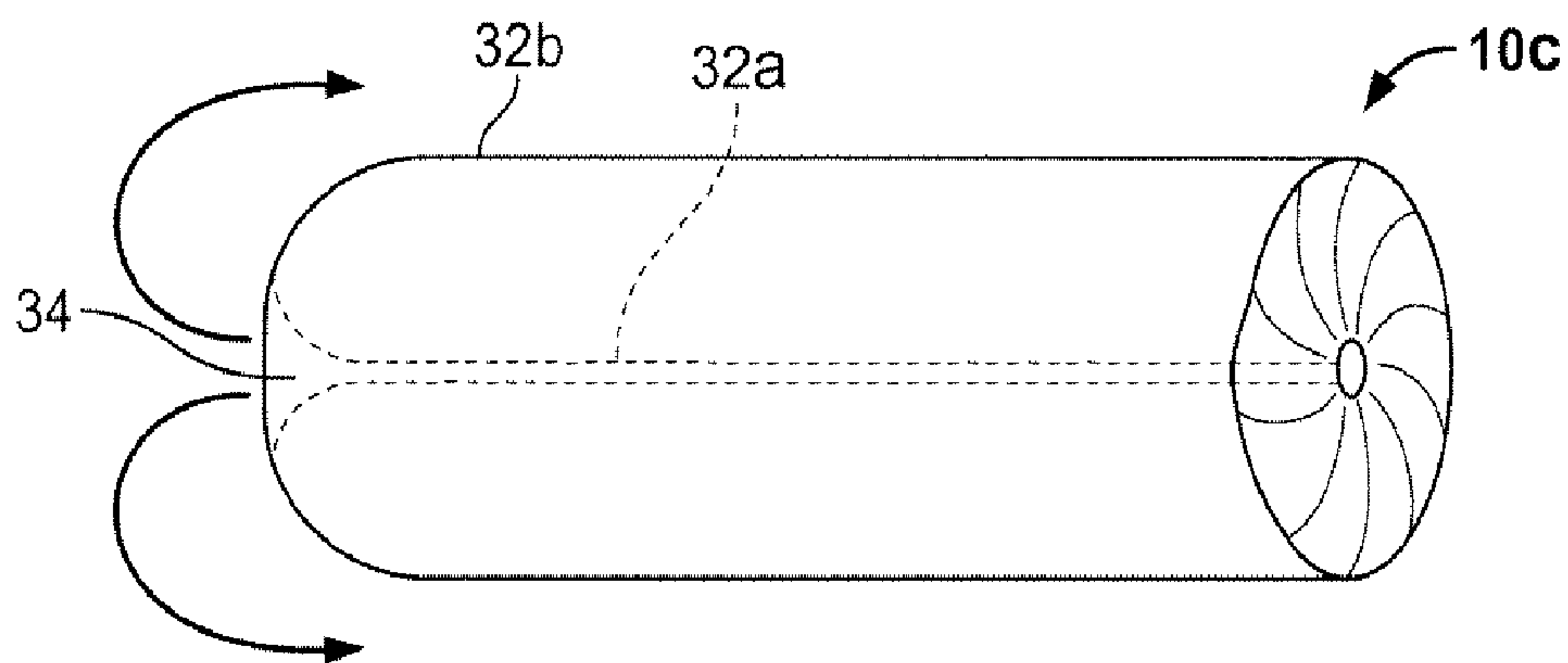

FIG. 7

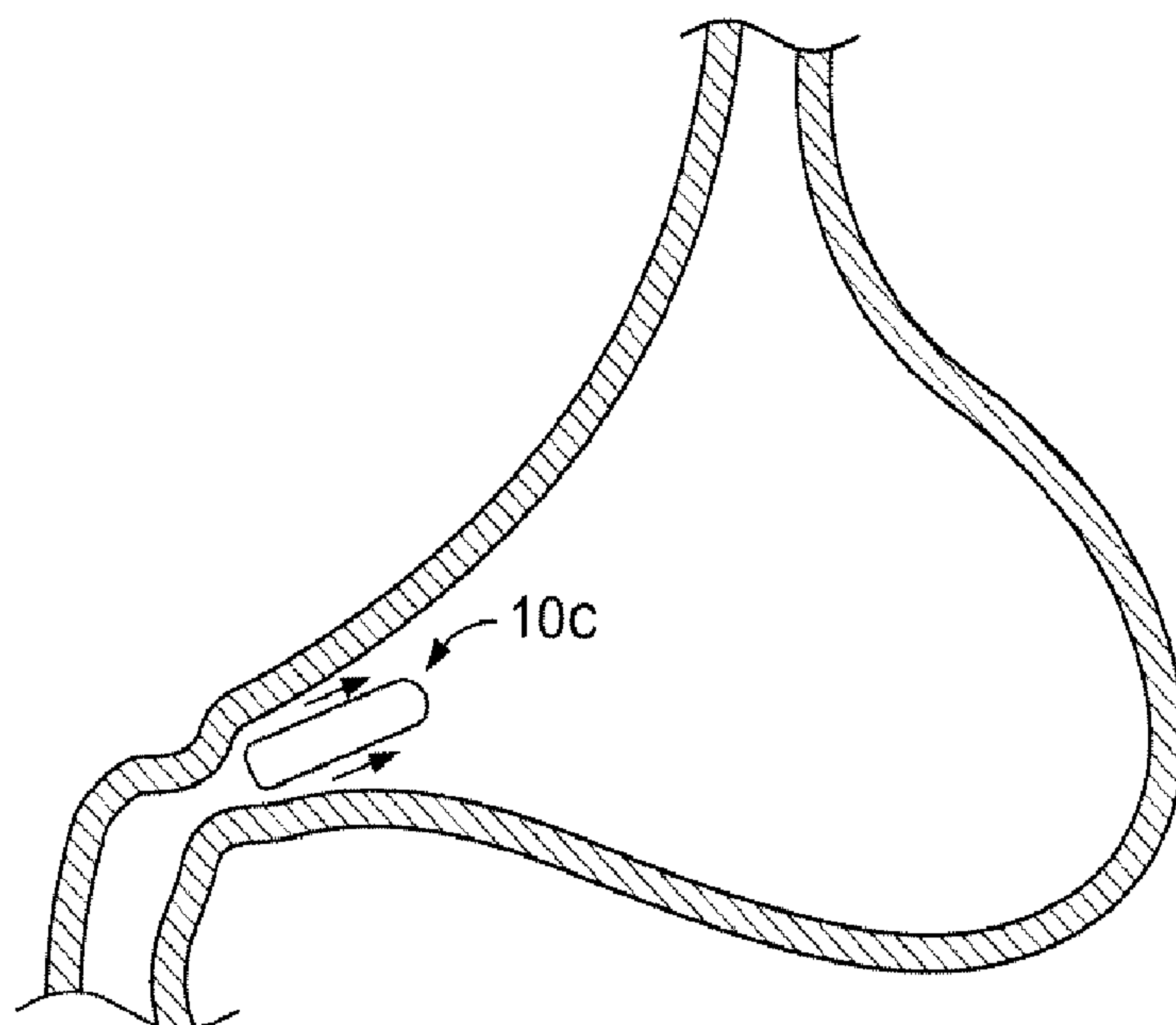

FIG. 8

4/4

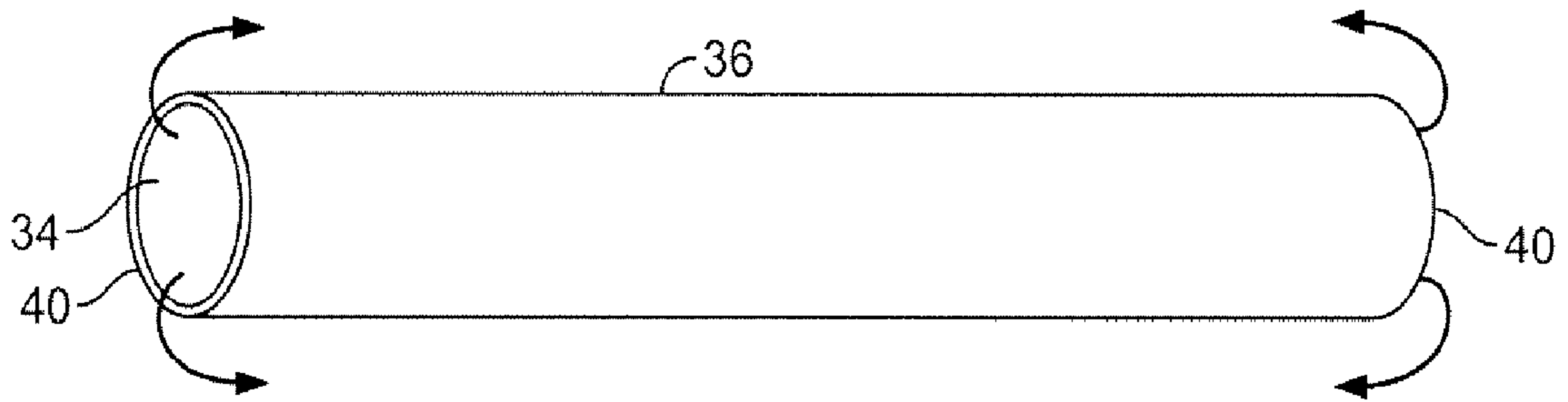

FIG. 9A

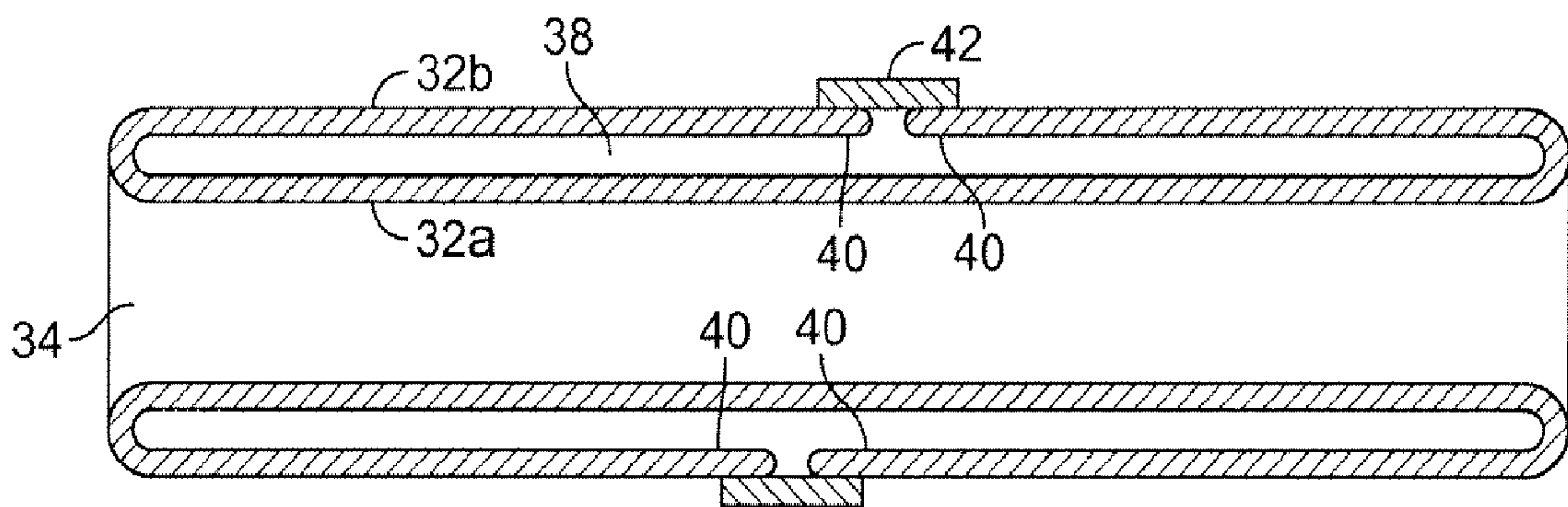

FIG. 9B

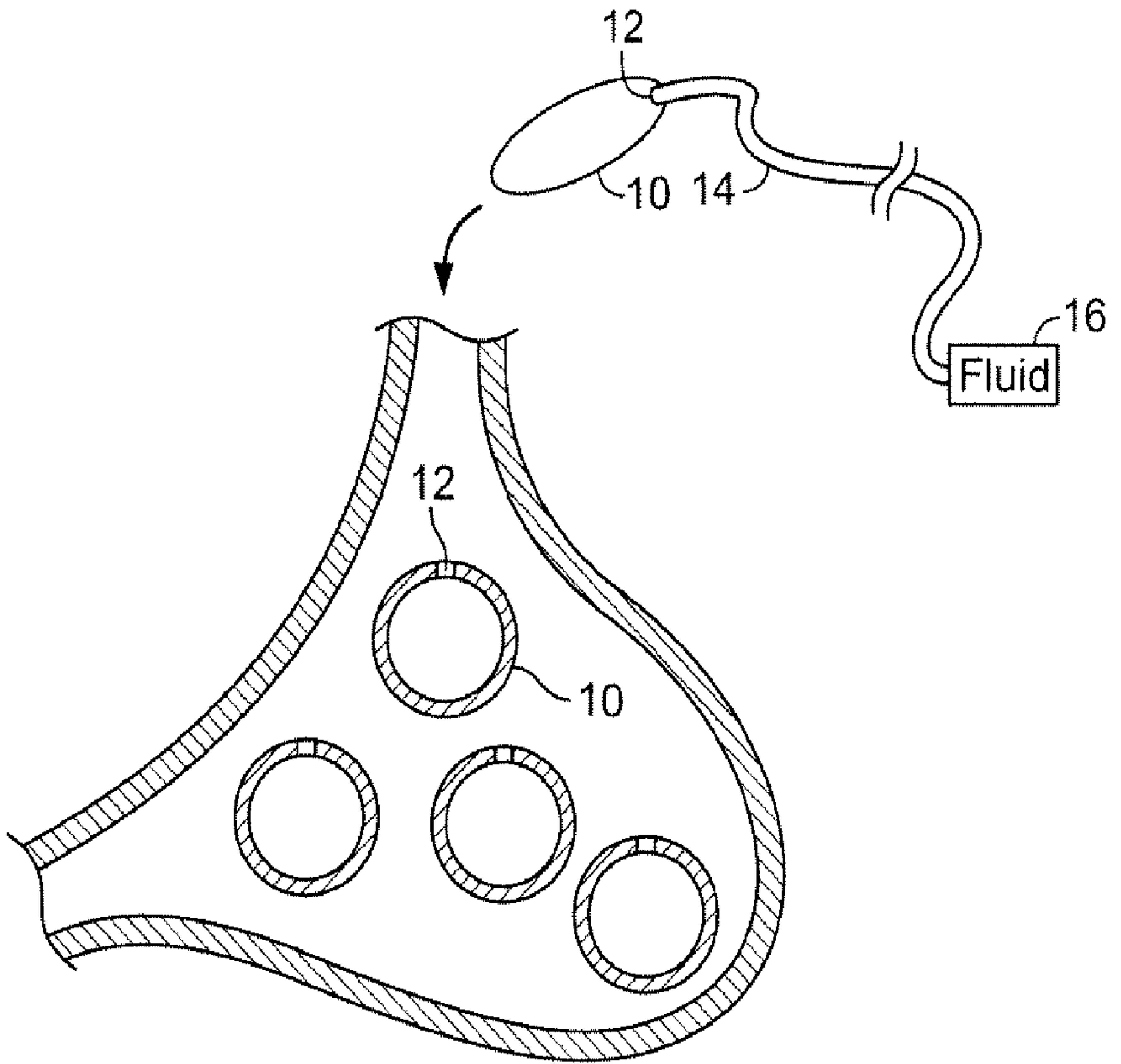

FIG. 1