



INTERNATIONAL APPLICATION PUBLISHED UNDER THE PATENT COOPERATION TREATY (PCT)

<p>(51) International Patent Classification⁶ : B41J 2/14</p>	<p>A1</p>	<p>(11) International Publication Number: WO 96/32280 (43) International Publication Date: 17 October 1996 (17.10.96)</p>
<p>(21) International Application Number: PCT/US96/04823 (22) International Filing Date: 10 April 1996 (10.04.96) (30) Priority Data: PN 2347 12 April 1995 (12.04.95) AU PN 2348 12 April 1995 (12.04.95) AU (71) Applicant (for all designated States except US): EASTMAN KODAK COMPANY [US/US]; 343 State Street, Rochester, NY 14650 (US). (72) Inventor; and (75) Inventor/Applicant (for US only): SILVERBROOK, Kia [AU/AU]; 214 Catherine Street, Leichhardt, NSW 2040 (AU). (74) Agent: SALES, Milton, S.; 343 State Street, Rochester, NY 14650-2201 (US).</p>		<p>(81) Designated States: JP, US, European patent (AT, BE, CH, DE, DK, ES, FI, FR, GB, GR, IE, IT, LU, MC, NL, PT, SE). Published <i>With international search report. Before the expiration of the time limit for amending the claims and to be republished in the event of the receipt of amendments.</i></p>

(54) Title: POWER SUPPLY CONNECTION FOR MONOLITHIC PRINT HEADS

(57) Abstract

Large print heads with many thousands of nozzles may have current consumption in excess of 20 Amperes. This would cause significant problems if standard interconnection techniques were used. The present invention effects very high current delivery to print heads by utilizing the entire long edges of the print head as power terminals. The V⁺ and V⁻ connections are fabricated as 200 μm wide strips of 1 μm aluminum along the edges of the chip which are perpendicular to the print direction. Lines of aluminum extend from the V⁺ connection until the row of nozzles closest to the V⁻ connection. These lines pass between every second nozzle, and are as wide as the device layout and process technology will allow. Lines of aluminum extend from the V⁻ connection until the row of nozzles closest to the V⁺ connection. These lines are interdigitated with the V⁺ lines. This power supply configuration allows tens of Amperes to be supplied to print heads with very low electrical resistance and without significant temperature rise in the on-chip connections. Also, electromigration is sufficiently low that it is not a significant factor in device reliability.

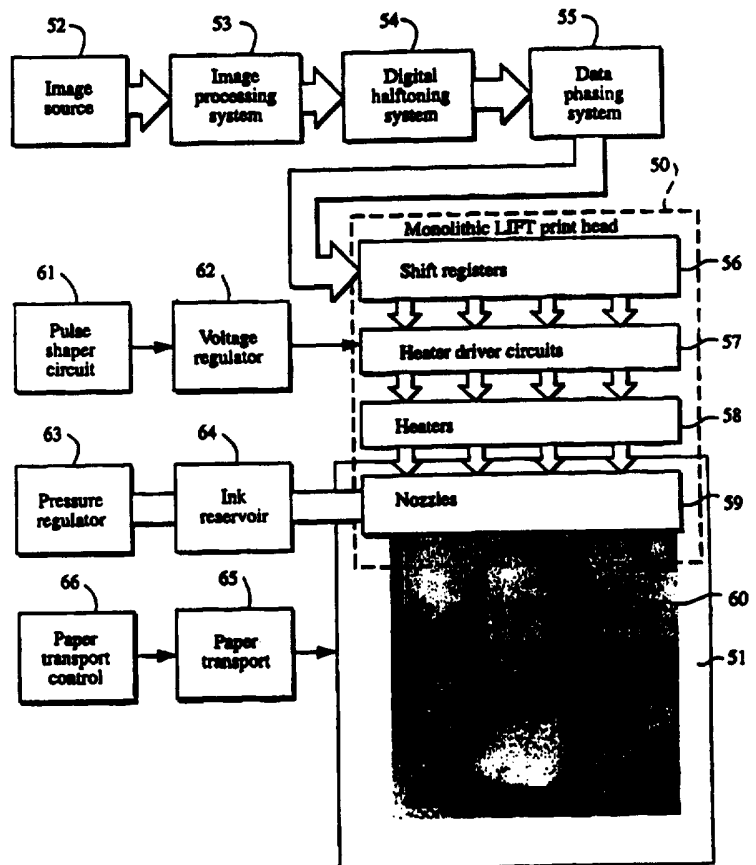

FOR THE PURPOSES OF INFORMATION ONLY

Codes used to identify States party to the PCT on the front pages of pamphlets publishing international applications under the PCT.

AM	Armenia	GB	United Kingdom	MW	Malawi
AT	Austria	GE	Georgia	MX	Mexico
AU	Australia	GN	Guinea	NE	Niger
BB	Barbados	GR	Greece	NL	Netherlands
BE	Belgium	HU	Hungary	NO	Norway
BF	Burkina Faso	IE	Ireland	NZ	New Zealand
BG	Bulgaria	IT	Italy	PL	Poland
BJ	Benin	JP	Japan	PT	Portugal
BR	Brazil	KE	Kenya	RO	Romania
BY	Belarus	KG	Kyrgyzstan	RU	Russian Federation
CA	Canada	KP	Democratic People's Republic of Korea	SD	Sudan
CF	Central African Republic	KR	Republic of Korea	SE	Sweden
CG	Congo	KZ	Kazakhstan	SG	Singapore
CH	Switzerland	LI	Liechtenstein	SI	Slovenia
CI	Côte d'Ivoire	LK	Sri Lanka	SK	Slovakia
CM	Cameroon	LR	Liberia	SN	Senegal
CN	China	LT	Lithuania	SZ	Swaziland
CS	Czechoslovakia	LU	Luxembourg	TD	Chad
CZ	Czech Republic	LV	Latvia	TG	Togo
DE	Germany	MC	Monaco	TJ	Tajikistan
DK	Denmark	MD	Republic of Moldova	TT	Trinidad and Tobago
EE	Estonia	MG	Madagascar	UA	Ukraine
ES	Spain	ML	Mali	UG	Uganda
FI	Finland	MN	Mongolia	US	United States of America
FR	France	MR	Mauritania	UZ	Uzbekistan
GA	Gabon			VN	Viet Nam

POWER SUPPLY CONNECTION FOR MONOLITHIC PRINT HEADS**Field of the Invention**

The present invention is in the field of computer controlled printing devices. In particular, the field is constructions and manufacturing processes for thermally activated drop on demand (DOD) printing heads which integrate multiple nozzles on a single substrate.

Background of the Invention

Many different types of digitally controlled printing systems have been invented, and many types are currently in production. These printing systems use a variety of actuation mechanisms, a variety of marking materials, and a variety of recording media. Examples of digital printing systems in current use include: laser electrophotographic printers; LED electrophotographic printers; dot matrix impact printers; thermal paper printers; film recorders; thermal wax printers; dye diffusion thermal transfer printers; and ink jet printers. However, at present, such electronic printing systems have not significantly replaced mechanical printing presses, even though this conventional method requires very expensive setup and is seldom commercially viable unless a few thousand copies of a particular page are to be printed. Thus, there is a need for improved digitally controlled printing systems, for example, being able to produce high quality color images at a high-speed and low cost, using standard paper.

Inkjet printing has become recognized as a prominent contender in the digitally controlled, electronic printing arena because, e.g., of its non-impact, low-noise characteristics, its use of plain paper and its avoidance of toner transfers and fixing.

Many types of ink jet printing mechanisms have been invented. These can be categorized as either continuous ink jet (CIJ) or drop on demand (DOD) ink jet. Continuous ink jet printing dates back to at least 1929: Hansell, US Pat. No. 1,941,001.

-2-

Sweet et al US Pat. No. 3,373,437, 1967, discloses an array of continuous ink jet nozzles where ink drops to be printed are selectively charged and deflected towards the recording medium. This technique is known as binary deflection CIJ, and is used by several manufacturers, including Elmjeter and Scitex.

5 Hertz et al US Pat. No. 3,416,153, 1966, discloses a method of achieving variable optical density of printed spots in CIJ printing using the electrostatic dispersion of a charged drop stream to modulate the number of droplets which pass through a small aperture. This technique is used in ink jet printers manufactured by Iris Graphics.

10 Kyser et al US Pat. No. 3,946,398, 1970, discloses a DOD ink jet printer which applies a high voltage to a piezoelectric crystal, causing the crystal to bend, applying pressure on an ink reservoir and jetting drops on demand. Many types of piezoelectric drop on demand printers have subsequently been invented, which utilize piezoelectric crystals in bend mode, push mode, shear mode, and
15 squeeze mode. Piezoelectric DOD printers have achieved commercial success using hot melt inks (for example, Tektronix and Dataproducts printers), and at image resolutions up to 720 dpi for home and office printers (Seiko Epson). Piezoelectric DOD printers have an advantage in being able to use a wide range of inks. However, piezoelectric printing mechanisms usually require complex high voltage
20 drive circuitry and bulky piezoelectric crystal arrays, which are disadvantageous in regard to manufacturability and performance.

Endo et al GB Pat. No. 2,007,162, 1979, discloses an electrothermal DOD ink jet printer which applies a power pulse to an electrothermal transducer (heater) which is in thermal contact with ink in a nozzle. The heater rapidly heats
25 water based ink to a high temperature, whereupon a small quantity of ink rapidly evaporates, forming a bubble. The formation of these bubbles results in a pressure wave which cause drops of ink to be ejected from small apertures along the edge of the heater substrate. This technology is known as Bubblejet™ (trademark of Canon K.K. of Japan), and is used in a wide range of printing systems from Canon, Xerox,
30 and other manufacturers.

-3-

Vaught et al US Pat. No. 4,490,728, 1982, discloses an electrothermal drop ejection system which also operates by bubble formation. In this system, drops are ejected in a direction normal to the plane of the heater substrate, through nozzles formed in an aperture plate positioned above the heater.

5 This system is known as Thermal Ink Jet, and is manufactured by Hewlett-Packard. In this document, the term Thermal Ink Jet is used to refer to both the Hewlett-Packard system and systems commonly known as Bubblejet™.

Thermal Ink Jet printing typically requires approximately 20 μ J over a period of approximately 2 μ s to eject each drop. The 10 Watt active power

10 consumption of each heater is disadvantageous in itself and also necessitates special inks, complicates the driver electronics and precipitates deterioration of heater elements.

Other ink jet printing systems have also been described in technical literature, but are not currently used on a commercial basis. For example, U.S.

15 Patent No. 4,275,290 discloses a system wherein the coincident address of predetermined print head nozzles with heat pulses and hydrostatic pressure, allows ink to flow freely to spacer-separated paper, passing beneath the print head. U.S. Patent Nos. 4,737,803; 4,737,803 and 4,748,458 disclose ink jet recording systems wherein the coincident address of ink in print head nozzles with heat pulses and an

20 electrostatically attractive field cause ejection of ink drops to a print sheet.

Each of the above-described inkjet printing systems has advantages and disadvantages. However, there remains a widely recognized need for an improved ink jet printing approach, providing advantages for example, as to cost, speed, quality, reliability, power usage, simplicity of construction and operation,

25 durability and consumables.

Summary of the invention

My concurrently filed applications, entitled "Liquid Ink Printing Apparatus and System" and "Coincident Drop-Selection, Drop-Separation Printing Method and System" describe new methods and apparatus that afford significant

-4-

improvements toward overcoming the prior art problems discussed above. Those inventions offer important advantages, e.g., in regard to drop size and placement accuracy, as to printing speeds attainable, as to power usage, as to durability and operative thermal stresses encountered and as to other printer performance characteristics, as well as in regard to manufacturability and the characteristics of useful inks. One important purpose of the present invention is to further enhance the structures and methods described in those applications and thereby contribute to the advancement of printing technology.

One object of the invention is to provide power supply connections for a drop-on-demand print head operating on the coincident forces printing principles.

In one aspect, the present invention constitutes a drop on demand print head comprising a plurality of electrothermal heater elements formed on a silicon chip and electrical power connections for supplying power to said electrothermal elements, the improvement wherein said connections are formed on the chip surface substantially at opposite edges of the print head and extend a distance substantially equal to the length of the corresponding edge.

In another aspect, the present invention constitutes a drop on demand print head comprising a plurality of integrated circuits formed on a silicon substrate, an arrangement of an electrical connection from said integrated circuit to an external circuit, said arrangement being characterized by the region of contact to said integrated circuit being situated in a bevel formed in the substrate of said integrated circuit.

Brief Description of the Drawings

Figure 1(a) shows a simplified block schematic diagram of one exemplary printing apparatus according to the present invention.

Figure 1(b) shows a cross section of one variety of nozzle tip in accordance with the invention.

Figures 2(a) to 2(f) show fluid dynamic simulations of drop selection.

-5-

Figure 3(a) shows a finite element fluid dynamic simulation of a nozzle in operation according to an embodiment of the invention.

Figure 3(b) shows successive meniscus positions during drop selection and separation.

5 Figure 3(c) shows the temperatures at various points during a drop selection cycle.

Figure 3(d) shows measured surface tension versus temperature curves for various ink additives.

10 Figure 3(e) shows the power pulses which are applied to the nozzle heater to generate the temperature curves of figure 3(c)

Figure 4 shows a block schematic diagram of print head drive circuitry for practice of the invention.

15 Figure 5 shows projected manufacturing yields for an A4 page width color print head embodying features of the invention, with and without fault tolerance.

Figure 6 shows a generalized block diagram of a printing system using a print head

Figure 7 shows a single silicon substrate with a multitude of nozzles etched in it.

20 Figures 8(a) to 8(d) shows a possible nozzle layouts and dimensions for a small section of a print head.

Figure 8(b) is a detail of figure 8(a).

Figures 9(a) to 9(o) show simplified manufacturing steps for the processes added to a standard integrated circuit fabrication.

25 Figures 10 show part of a layout for a 6 color print head, showing high current power connections.

Figure 11(a) shows an arrangement of nozzles for a small part of one color of a print head.

30 Figure 11(b) is a detail enlargement of the region around three of the nozzles shown in figure 11(a).

-6-

Figures 12(a) and 12(b) are cross-section views showing a connection for print heads which overcomes problems with conventional systems.

Detailed Description of Preferred Embodiments

In one general aspect, the invention constitutes a drop-on-demand
5 printing mechanism wherein the means of selecting drops to be printed produces a difference in position between selected drops and drops which are not selected, but which is insufficient to cause the ink drops to overcome the ink surface tension and separate from the body of ink, and wherein an alternative means is provided to cause separation of the selected drops from the body of ink.

10 The separation of drop selection means from drop separation means significantly reduces the energy required to select which ink drops are to be printed. Only the drop selection means must be driven by individual signals to each nozzle. The drop separation means can be a field or condition applied simultaneously to all nozzles.

15 The drop selection means may be chosen from, but is not limited to, the following list:

- 1) Electrothermal reduction of surface tension of pressurized ink
- 2) Electrothermal bubble generation, with insufficient bubble volume to cause drop ejection
- 20 3) Piezoelectric, with insufficient volume change to cause drop ejection
- 4) Electrostatic attraction with one electrode per nozzle

The drop separation means may be chosen from, but is not limited to, the following list:

- 1) Proximity (recording medium in close proximity to print head)
- 25 2) Proximity with oscillating ink pressure
- 3) Electrostatic attraction
- 4) Magnetic attraction

The table "DOD printing technology targets" shows some desirable characteristics of drop on demand printing technology. The table also lists some
30 methods by which some embodiments described herein, or in other of my related applications, provide improvements over the prior art.

-7-

DOD printing technology targets

Target	Method of achieving improvement over prior art
High speed operation	Practical, low cost, pagewidth printing heads with more than 10,000 nozzles. Monolithic A4 pagewidth print heads can be manufactured using standard 300 mm (12") silicon wafers
High image quality	High resolution (800 dpi is sufficient for most applications), six color process to reduce image noise
Full color operation	Halftoned process color at 800 dpi using stochastic screening
Ink flexibility	Low operating ink temperature and no requirement for bubble formation
Low power requirements	Low power operation results from drop selection means not being required to fully eject drop
Low cost	Monolithic print head without aperture plate, high manufacturing yield, small number of electrical connections, use of modified existing CMOS manufacturing facilities
High manufacturing yield	Integrated fault tolerance in printing head
High reliability	Integrated fault tolerance in printing head. Elimination of cavitation and kogation. Reduction of thermal shock.
Small number of electrical connections	Shift registers, control logic, and drive circuitry can be integrated on a monolithic print head using standard CMOS processes
Use of existing VLSI manufacturing facilities	CMOS compatibility. This can be achieved because the heater drive power is less than 1% of Thermal Ink Jet heater drive power
Electronic collation	A new page compression system which can achieve 100:1 compression with insignificant image degradation, resulting in a compressed data rate low enough to allow real-time printing of any combination of thousands of pages stored on a low cost magnetic disk drive.

In thermal ink jet (TIJ) and piezoelectric ink jet systems, a drop velocity of approximately 10 meters per second is preferred to ensure that the selected ink drops overcome ink surface tension, separate from the body of the ink,

-8-

and strike the recording medium. These systems have a very low efficiency of conversion of electrical energy into drop kinetic energy. The efficiency of TIJ systems is approximately 0.02%). This means that the drive circuits for TIJ print heads must switch high currents. The drive circuits for piezoelectric ink jet heads must either switch high voltages, or drive highly capacitive loads. The total power consumption of pagewidth TIJ printheads is also very high. An 800 dpi A4 full color pagewidth TIJ print head printing a four color black image in one second would consume approximately 6 kW of electrical power, most of which is converted to waste heat. The difficulties of removal of this amount of heat precludes the production of low cost, high speed, high resolution compact pagewidth TIJ systems.

One important feature of embodiments of the invention is a means of significantly reducing the energy required to select which ink drops are to be printed. This is achieved by separating the means for selecting ink drops from the means for ensuring that selected drops separate from the body of ink and form dots on the recording medium. Only the drop selection means must be driven by individual signals to each nozzle. The drop separation means can be a field or condition applied simultaneously to all nozzles.

The table "Drop selection means" shows some of the possible means for selecting drops in accordance with the invention. The drop selection means is only required to create sufficient change in the position of selected drops that the drop separation means can discriminate between selected and unselected drops.

Drop selection means

Method	Advantage	Limitation
1. Electrothermal reduction of surface tension of pressurized ink	Low temperature increase and low drop selection energy. Can be used with many ink types. Simple fabrication. CMOS drive circuits can be fabricated on same substrate	Requires ink pressure regulating mechanism. Ink surface tension must reduce substantially as temperature increases
2. Electrothermal reduction of ink viscosity, combined with oscillating ink pressure	Medium drop selection energy, suitable for hot melt and oil based inks. Simple fabrication. CMOS drive circuits can be fabricated on same substrate	Requires ink pressure oscillation mechanism. Ink must have a large decrease in viscosity as temperature increases
3. Electrothermal bubble generation, with insufficient bubble volume to cause drop ejection	Well known technology, simple fabrication, bipolar drive circuits can be fabricated on same substrate	High drop selection energy, requires water based ink, problems with kogation, cavitation, thermal stress
4. Piezoelectric, with insufficient volume change to cause drop ejection	Many types of ink base can be used	High manufacturing cost, incompatible with integrated circuit processes, high drive voltage, mechanical complexity, bulky
5. Electrostatic attraction with one electrode per nozzle	Simple electrode fabrication	Nozzle pitch must be relatively large. Crosstalk between adjacent electric fields. Requires high voltage drive circuits

Other drop selection means may also be used.

The preferred drop selection means for water based inks is method

- 5 1: "Electrothermal reduction of surface tension of pressurized ink". This drop selection means provides many advantages over other systems, including; low power operation (approximately 1% of TIJ), compatibility with CMOS VLSI chip

-10-

fabrication, low voltage operation (approx. 10 V), high nozzle density, low temperature operation, and wide range of suitable ink formulations. The ink must exhibit a reduction in surface tension with increasing temperature.

The preferred drop selection means for hot melt or oil based inks is method 2: "Electrothermal reduction of ink viscosity, combined with oscillating ink pressure". This drop selection means is particularly suited for use with inks which exhibit a large reduction of viscosity with increasing temperature, but only a small reduction in surface tension. This occurs particularly with non-polar ink carriers with relatively high molecular weight. This is especially applicable to hot melt and oil based inks.

The table "Drop separation means" shows some of the possible methods for separating selected drops from the body of ink, and ensuring that the selected drops form dots on the printing medium. The drop separation means discriminates between selected drops and unselected drops to ensure that unselected drops do not form dots on the printing medium.

Drop separation means

Means	Advantage	Limitation
1. Electrostatic attraction	Can print on rough surfaces, simple implementation	Requires high voltage power supply
2. AC electric field	Higher field strength is possible than electrostatic, operating margins can be increased, ink pressure reduced, and dust accumulation is reduced	Requires high voltage AC power supply synchronized to drop ejection phase. Multiple drop phase operation is difficult
3. Proximity (print head in close proximity to, but not touching, recording medium)	Very small spot sizes can be achieved. Very low power dissipation. High drop position accuracy	Requires print medium to be very close to print head surface, not suitable for rough print media, usually requires transfer roller or belt

-11-

4. Transfer Proximity (print head is in close proximity to a transfer roller or belt)	Very small spot sizes can be achieved, very low power dissipation, high accuracy, can print on rough paper	Not compact due to size of transfer roller or transfer belt.
5. Proximity with oscillating ink pressure	Useful for hot melt inks using viscosity reduction drop selection method, reduces possibility of nozzle clogging, can use pigments instead of dyes	Requires print medium to be very close to print head surface, not suitable for rough print media. Requires ink pressure oscillation apparatus
6. Magnetic attraction	Can print on rough surfaces. Low power if permanent magnets are used	Requires uniform high magnetic field strength, requires magnetic ink

Other drop separation means may also be used.

The preferred drop separation means depends upon the intended use.

For most applications, method 1: "Electrostatic attraction", or method 2: "AC electric field" are most appropriate. For applications where smooth coated paper or film is used, and very high speed is not essential, method 3: "Proximity" may be appropriate. For high speed, high quality systems, method 4: "Transfer proximity" can be used. Method 6: "Magnetic attraction" is appropriate for portable printing systems where the print medium is too rough for proximity printing, and the high voltages required for electrostatic drop separation are undesirable. There is no clear 'best' drop separation means which is applicable to all circumstances.

Further details of various types of printing systems according to the present invention are described in the following Australian patent specifications filed on 12 April 1995, the disclosure of which are hereby incorporated by reference:

- 15 'A Liquid ink Fault Tolerant (LIFT) printing mechanism' (Filing no.: PN2308);
 'Electrothermal drop selection in LIFT printing' (Filing no.: PN2309);
 'Drop separation in LIFT printing by print media proximity' (Filing no.: PN2310);

-12-

'Drop size adjustment in Proximity LIFT printing by varying head to media distance' (Filing no.: PN2311);

'Augmenting Proximity LIFT printing with acoustic ink waves' (Filing no.: PN2312);

5 'Electrostatic drop separation in LIFT printing' (Filing no.: PN2313);

'Multiple simultaneous drop sizes in Proximity LIFT printing' (Filing no.: PN2321);

'Self cooling operation in thermally activated print heads' (Filing no.: PN2322); and

10 'Thermal Viscosity Reduction LIFT printing' (Filing no.: PN2323).

A simplified schematic diagram of one preferred printing system according to the invention appears in Figure 1(a).

An image source 52 may be raster image data from a scanner or computer, or outline image data in the form of a page description language (PDL),
15 or other forms of digital image representation. This image data is converted to a pixel-mapped page image by the image processing system 53. This may be a raster image processor (RIP) in the case of PDL image data, or may be pixel image manipulation in the case of raster image data. Continuous tone data produced by the image processing unit 53 is halftoned. Halftoning is performed by the Digital
20 Halftoning unit 54. Halftoned bitmap image data is stored in the image memory 72. Depending upon the printer and system configuration, the image memory 72 may be a full page memory, or a band memory. Heater control circuits 71 read data from the image memory 72 and apply time-varying electrical pulses to the nozzle heaters (103 in figure 1(b)) that are part of the print head 50. These pulses are applied at an
25 appropriate time, and to the appropriate nozzle, so that selected drops will form spots on the recording medium 51 in the appropriate position designated by the data in the image memory 72.

The recording medium 51 is moved relative to the head 50 by a paper transport system 65, which is electronically controlled by a paper transport
30 control system 66, which in turn is controlled by a microcontroller 315. The paper transport system shown in figure 1(a) is schematic only, and many different

-13-

mechanical configurations are possible. In the case of pagewidth print heads, it is most convenient to move the recording medium 51 past a stationary head 50. However, in the case of scanning print systems, it is usually most convenient to move the head 50 along one axis (the sub-scanning direction) and the recording medium 51 along the orthogonal axis (the main scanning direction), in a relative raster motion. The microcontroller 315 may also control the ink pressure regulator 63 and the heater control circuits 71.

For printing using surface tension reduction, ink is contained in an ink reservoir 64 under pressure. In the quiescent state (with no ink drop ejected), the ink pressure is insufficient to overcome the ink surface tension and eject a drop. A constant ink pressure can be achieved by applying pressure to the ink reservoir 64 under the control of an ink pressure regulator 63. Alternatively, for larger printing systems, the ink pressure can be very accurately generated and controlled by situating the top surface of the ink in the reservoir 64 an appropriate distance above the head 50. This ink level can be regulated by a simple float valve (not shown).

For printing using viscosity reduction, ink is contained in an ink reservoir 64 under pressure, and the ink pressure is caused to oscillate. The means of producing this oscillation may be a piezoelectric actuator mounted in the ink channels (not shown).

When properly arranged with the drop separation means, selected drops proceed to form spots on the recording medium 51, while unselected drops remain part of the body of ink.

The ink is distributed to the back surface of the head 50 by an ink channel device 75. The ink preferably flows through slots and/or holes etched through the silicon substrate of the head 50 to the front surface, where the nozzles and actuators are situated. In the case of thermal selection, the nozzle actuators are electrothermal heaters.

In some types of printers according to the invention, an external field 74 is required to ensure that the selected drop separates from the body of the ink and moves towards the recording medium 51. A convenient external field 74 is a

-14-

constant electric field, as the ink is easily made to be electrically conductive. In this case, the paper guide or platen 67 can be made of electrically conductive material and used as one electrode generating the electric field. The other electrode can be the head 50 itself. Another embodiment uses proximity of the print medium as a
5 means of discriminating between selected drops and unselected drops.

For small drop sizes gravitational force on the ink drop is very small; approximately 10^{-4} of the surface tension forces, so gravity can be ignored in most cases. This allows the print head 50 and recording medium 51 to be oriented in any direction in relation to the local gravitational field. This is an important requirement
10 for portable printers.

Figure 1(b) is a detail enlargement of a cross section of a single microscopic nozzle tip embodiment of the invention, fabricated using a modified CMOS process. The nozzle is etched in a substrate 101, which may be silicon, glass, metal, or any other suitable material. If substrates which are not
15 semiconductor materials are used, a semiconducting material (such as amorphous silicon) may be deposited on the substrate, and integrated drive transistors and data distribution circuitry may be formed in the surface semiconducting layer. Single crystal silicon (SCS) substrates have several advantages, including:

- 20 1) High performance drive transistors and other circuitry can be fabricated in SCS;
- 2) Print heads can be fabricated in existing facilities (fabs) using standard VLSI processing equipment;
- 3) SCS has high mechanical strength and rigidity; and
- 4) SCS has a high thermal conductivity.

25 In this example, the nozzle is of cylindrical form, with the heater 103 forming an annulus. The nozzle tip 104 is formed from silicon dioxide layers 102 deposited during the fabrication of the CMOS drive circuitry. The nozzle tip is passivated with silicon nitride. The protruding nozzle tip controls the contact point of the pressurized ink 100 on the print head surface. The print head surface is also
30 hydrophobized to prevent accidental spread of ink across the front of the print head.

-15-

Many other configurations of nozzles are possible, and nozzle embodiments of the invention may vary in shape, dimensions, and materials used. Monolithic nozzles etched from the substrate upon which the heater and drive electronics are formed have the advantage of not requiring an orifice plate. The elimination of the orifice plate has significant cost savings in manufacture and assembly. Recent methods for eliminating orifice plates include the use of 'vortex' actuators such as those described in Domoto et al US Pat. No. 4,580,158, 1986, assigned to Xerox, and Miller et al US Pat. No. 5,371,527, 1994 assigned to Hewlett-Packard. These, however are complex to actuate, and difficult to fabricate. The preferred method for elimination of orifice plates for print heads of the invention is incorporation of the orifice into the actuator substrate.

This type of nozzle may be used for print heads using various techniques for drop separation.

Operation with Electrostatic Drop Separation

As a first example, operation using thermal reduction of surface tension and electrostatic drop separation is shown in figure 2.

Figure 2 shows the results of energy transport and fluid dynamic simulations performed using FIDAP, a commercial fluid dynamic simulation software package available from Fluid Dynamics Inc., of Illinois, USA. This simulation is of a thermal drop selection nozzle embodiment with a diameter of 8 μm , at an ambient temperature of 30°C. The total energy applied to the heater is 276 nJ, applied as 69 pulses of 4 nJ each. The ink pressure is 10 kPa above ambient air pressure, and the ink viscosity at 30°C is 1.84 cPs. The ink is water based, and includes a sol of 0.1% palmitic acid to achieve an enhanced decrease in surface tension with increasing temperature. A cross section of the nozzle tip from the central axis of the nozzle to a radial distance of 40 μm is shown. Heat flow in the various materials of the nozzle, including silicon, silicon nitride, amorphous silicon dioxide, crystalline silicon dioxide, and water based ink are simulated using the

-16-

respective densities, heat capacities, and thermal conductivities of the materials. The time step of the simulation is 0.1 μs .

Figure 2(a) shows a quiescent state, just before the heater is actuated. An equilibrium is created whereby no ink escapes the nozzle in the quiescent state by ensuring that the ink pressure plus external electrostatic field is insufficient to overcome the surface tension of the ink at the ambient temperature. In the quiescent state, the meniscus of the ink does not protrude significantly from the print head surface, so the electrostatic field is not significantly concentrated at the meniscus.

Figure 2(b) shows thermal contours at 5°C intervals 5 μs after the start of the heater energizing pulse. When the heater is energized, the ink in contact with the nozzle tip is rapidly heated. The reduction in surface tension causes the heated portion of the meniscus to rapidly expand relative to the cool ink meniscus. This drives a convective flow which rapidly transports this heat over part of the free surface of the ink at the nozzle tip. It is necessary for the heat to be distributed over the ink surface, and not just where the ink is in contact with the heater. This is because viscous drag against the solid heater prevents the ink directly in contact with the heater from moving.

Figure 2(c) shows thermal contours at 5°C intervals 10 μs after the start of the heater energizing pulse. The increase in temperature causes a decrease in surface tension, disturbing the equilibrium of forces. As the entire meniscus has been heated, the ink begins to flow.

Figure 2(d) shows thermal contours at 5°C intervals 20 μs after the start of the heater energizing pulse. The ink pressure has caused the ink to flow to a new meniscus position, which protrudes from the print head. The electrostatic field becomes concentrated by the protruding conductive ink drop.

Figure 2(e) shows thermal contours at 5°C intervals 30 μs after the start of the heater energizing pulse, which is also 6 μs after the end of the heater pulse, as the heater pulse duration is 24 μs . The nozzle tip has rapidly cooled due to conduction through the oxide layers, and conduction into the flowing ink. The

-17-

nozzle tip is effectively 'water cooled' by the ink. Electrostatic attraction causes the ink drop to begin to accelerate towards the recording medium. Were the heater pulse significantly shorter (less than 16 μ s in this case) the ink would not accelerate towards the print medium, but would instead return to the nozzle.

5 Figure 2(f) shows thermal contours at 5°C intervals 26 μ s after the end of the heater pulse. The temperature at the nozzle tip is now less than 5°C above ambient temperature. This causes an increase in surface tension around the nozzle tip. When the rate at which the ink is drawn from the nozzle exceeds the viscously limited rate of ink flow through the nozzle, the ink in the region of the
10 nozzle tip 'necks', and the selected drop separates from the body of ink. The selected drop then travels to the recording medium under the influence of the external electrostatic field. The meniscus of the ink at the nozzle tip then returns to its quiescent position, ready for the next heat pulse to select the next ink drop. One ink drop is selected, separated and forms a spot on the recording medium for each
15 heat pulse. As the heat pulses are electrically controlled, drop on demand ink jet operation can be achieved.

Figure 3(a) shows successive meniscus positions during the drop selection cycle at 5 μ s intervals, starting at the beginning of the heater energizing pulse.

20 Figure 3(b) is a graph of meniscus position versus time, showing the movement of the point at the centre of the meniscus. The heater pulse starts 10 μ s into the simulation.

Figure 3(c) shows the resultant curve of temperature with respect to time at various points in the nozzle. The vertical axis of the graph is temperature, in
25 units of 100°C. The horizontal axis of the graph is time, in units of 10 μ s. The temperature curve shown in figure 3(b) was calculated by FIDAP, using 0.1 μ s time steps. The local ambient temperature is 30 degrees C. Temperature histories at three points are shown:

30 A - Nozzle tip: This shows the temperature history at the circle of contact between the passivation layer, the ink, and air.

-18-

B - Meniscus midpoint: This is at a circle on the ink meniscus midway between the nozzle tip and the centre of the meniscus.

C - Chip surface: This is at a point on the print head surface 20 μm from the centre of the nozzle. The temperature only rises a few degrees. This
5 indicates that active circuitry can be located very close to the nozzles without experiencing performance or lifetime degradation due to elevated temperatures.

Figure 3(e) shows the power applied to the heater. Optimum operation requires a sharp rise in temperature at the start of the heater pulse, a maintenance of the temperature a little below the boiling point of the ink for the
10 duration of the pulse, and a rapid fall in temperature at the end of the pulse. To achieve this, the average energy applied to the heater is varied over the duration of the pulse. In this case, the variation is achieved by pulse frequency modulation of 0.1 μs sub-pulses, each with an energy of 4 nJ. The peak power applied to the heater is 40 mW, and the average power over the duration of the heater pulse is
15 11.5 mW. The sub-pulse frequency in this case is 5 Mhz. This can readily be varied without significantly affecting the operation of the print head. A higher sub-pulse frequency allows finer control over the power applied to the heater. A sub-pulse frequency of 13.5 Mhz is suitable, as this frequency is also suitable for minimizing the effect of radio frequency interference (RFI).

20 Inks with a negative temperature coefficient of surface tension

The requirement for the surface tension of the ink to decrease with increasing temperature is not a major restriction, as most pure liquids and many mixtures have this property. Exact equations relating surface tension to temperature for arbitrary liquids are not available. However, the following empirical equation
25 derived by Ramsay and Shields is satisfactory for many liquids:

$$\gamma_T = k \frac{(T_c - T - 6)}{\sqrt{\left(\frac{Mx}{\rho}\right)^2}}$$

Where γ_T is the surface tension at temperature T , k is a constant, T_c is the critical temperature of the liquid, M is the molar mass of the liquid, x is the

-19-

degree of association of the liquid, and ρ is the density of the liquid. This equation indicates that the surface tension of most liquids falls to zero as the temperature reaches the critical temperature of the liquid. For most liquids, the critical temperature is substantially above the boiling point at atmospheric pressure, so to
5 achieve an ink with a large change in surface tension with a small change in temperature around a practical ejection temperature, the admixture of surfactants is recommended.

The choice of surfactant is important. For example, water based ink for thermal ink jet printers often contains isopropyl alcohol (2-propanol) to reduce
10 the surface tension and promote rapid drying. Isopropyl alcohol has a boiling point of 82.4°C, lower than that of water. As the temperature rises, the alcohol evaporates faster than the water, decreasing the alcohol concentration and causing an increase in surface tension. A surfactant such as 1-Hexanol (b.p. 158°C) can be used to reverse this effect, and achieve a surface tension which decreases slightly
15 with temperature. However, a relatively large decrease in surface tension with temperature is desirable to maximize operating latitude. A surface tension decrease of 20 mN/m over a 30°C temperature range is preferred to achieve large operating margins, while as little as 10mN/m can be used to achieve operation of the print head according to the present invention.

20 Inks With Large $-\Delta\gamma_T$

Several methods may be used to achieve a large negative change in surface tension with increasing temperature. Two such methods are:

- 1) The ink may contain a low concentration sol of a surfactant which is solid at ambient temperatures, but melts at a threshold temperature. Particle sizes less
25 than 1,000 Å are desirable. Suitable surfactant melting points for a water based ink are between 50°C and 90°C, and preferably between 60°C and 80°C.
- 2) The ink may contain an oil/water microemulsion with a phase inversion temperature (PIT) which is above the maximum ambient temperature, but below the boiling point of the ink. For stability, the PIT of the microemulsion

-20-

is preferably 20°C or more above the maximum non-operating temperature encountered by the ink. A PIT of approximately 80°C is suitable.

Inks with Surfactant Sols

Inks can be prepared as a sol of small particles of a surfactant which melts in the desired operating temperature range. Examples of such surfactants include carboxylic acids with between 14 and 30 carbon atoms, such as:

Name	Formula	m.p.	Synonym
Tetradecanoic acid	CH ₃ (CH ₂) ₁₂ COOH	58°C	Myristic acid
Hexadecanoic acid	CH ₃ (CH ₂) ₁₄ COOH	63°C	Palmitic acid
Octadecanoic acid	CH ₃ (CH ₂) ₁₅ COOH	71°C	Stearic acid
Eicosanoic acid	CH ₃ (CH ₂) ₁₆ COOH	77°C	Arachidic acid
Docosanoic acid	CH ₃ (CH ₂) ₂₀ COOH	80°C	Behenic acid

As the melting point of sols with a small particle size is usually slightly less than of the bulk material, it is preferable to choose a carboxylic acid with a melting point slightly above the desired drop selection temperature. A good example is Arachidic acid.

These carboxylic acids are available in high purity and at low cost. The amount of surfactant required is very small, so the cost of adding them to the ink is insignificant. A mixture of carboxylic acids with slightly varying chain lengths can be used to spread the melting points over a range of temperatures. Such mixtures will typically cost less than the pure acid.

It is not necessary to restrict the choice of surfactant to simple unbranched carboxylic acids. Surfactants with branched chains or phenyl groups, or other hydrophobic moieties can be used. It is also not necessary to use a carboxylic acid. Many highly polar moieties are suitable for the hydrophilic end of the surfactant. It is desirable that the polar end be ionizable in water, so that the surface of the surfactant particles can be charged to aid dispersion and prevent flocculation.

-21-

In the case of carboxylic acids, this can be achieved by adding an alkali such as sodium hydroxide or potassium hydroxide.

Preparation of Inks with Surfactant Sols

The surfactant sol can be prepared separately at high concentration,
5 and added to the ink in the required concentration.

An example process for creating the surfactant sol is as follows:

- 1) Add the carboxylic acid to purified water in an oxygen free atmosphere.
- 2) Heat the mixture to above the melting point of the carboxylic acid. The water can be brought to a boil.
- 10 3) Ultrasonicate the mixture, until the typical size of the carboxylic acid droplets is between 100Å and 1,000Å.
- 4) Allow the mixture to cool.
- 5) Decant the larger particles from the top of the mixture.
- 6) Add an alkali such as NaOH to ionize the carboxylic acid molecules on the
15 surface of the particles. A pH of approximately 8 is suitable. This step is not absolutely necessary, but helps stabilize the sol.
- 7) Centrifuge the sol. As the density of the carboxylic acid is lower than water, smaller particles will accumulate at the outside of the centrifuge, and larger particles in the centre.
- 20 8) Filter the sol using a microporous filter to eliminate any particles above 5000 Å.
- 9) Add the surfactant sol to the ink preparation. The sol is required only in very dilute concentration.

The ink preparation will also contain either dye(s) or pigment(s),
25 bactericidal agents, agents to enhance the electrical conductivity of the ink if electrostatic drop separation is used, humectants, and other agents as required.

Anti-foaming agents will generally not be required, as there is no bubble formation during the drop ejection process.

-22-

Cationic surfactant sols

Inks made with anionic surfactant sols are generally unsuitable for use with cationic dyes or pigments. This is because the cationic dye or pigment may precipitate or flocculate with the anionic surfactant. To allow the use of cationic dyes and pigments, a cationic surfactant sol is required. The family of alkylamines is suitable for this purpose.

Various suitable alkylamines are shown in the following table:

Name	Formula	Synonym
Hexadecylamine	$\text{CH}_3(\text{CH}_2)_{14}\text{CH}_2\text{NH}_2$	Palmityl amine
Octadecylamine	$\text{CH}_3(\text{CH}_2)_{16}\text{CH}_2\text{NH}_2$	Stearyl amine
Eicosylamine	$\text{CH}_3(\text{CH}_2)_{18}\text{CH}_2\text{NH}_2$	Arachidyl amine
Docosylamine	$\text{CH}_3(\text{CH}_2)_{20}\text{CH}_2\text{NH}_2$	Behenyl amine

The method of preparation of cationic surfactant sols is essentially similar to that of anionic surfactant sols, except that an acid instead of an alkali is used to adjust the pH balance and increase the charge on the surfactant particles. A pH of 6 using HCl is suitable.

Microemulsion Based Inks

An alternative means of achieving a large reduction in surface tension as some temperature threshold is to base the ink on a microemulsion. A microemulsion is chosen with a phase inversion temperature (PIT) around the desired ejection threshold temperature. Below the PIT, the microemulsion is oil in water (O/W), and above the PIT the microemulsion is water in oil (W/O). At low temperatures, the surfactant forming the microemulsion prefers a high curvature surface around oil, and at temperatures significantly above the PIT, the surfactant prefers a high curvature surface around water. At temperatures close to the PIT, the microemulsion forms a continuous 'sponge' of topologically connected water and oil.

-23-

There are two mechanisms whereby this reduces the surface tension. Around the PIT, the surfactant prefers surfaces with very low curvature. As a result, surfactant molecules migrate to the ink/air interface, which has a curvature which is much less than the curvature of the oil emulsion. This lowers the surface tension of the water. Above the phase inversion temperature, the microemulsion changes from O/W to W/O, and therefore the ink/air interface changes from water/air to oil/air. The oil/air interface has a lower surface tension.

There is a wide range of possibilities for the preparation of microemulsion based inks.

10 For fast drop ejection, it is preferable to chose a low viscosity oil.

In many instances, water is a suitable polar solvent. However, in some cases different polar solvents may be required. In these cases, polar solvents with a high surface tension should be chosen, so that a large decrease in surface tension is achievable.

15 The surfactant can be chosen to result in a phase inversion temperature in the desired range. For example, surfactants of the group poly(oxyethylene)alkylphenyl ether (ethoxylated alkyl phenols, general formula: $C_nH_{2n+1}C_4H_9(CH_2CH_2O)_mOH$) can be used. The hydrophilicity of the surfactant can be increased by increasing m, and the hydrophobicity can be increased by increasing n. Values of m of approximately 10, and n of approximately 8 are suitable.

20 Low cost commercial preparations are the result of a polymerization of various molar ratios of ethylene oxide and alkyl phenols, and the exact number of oxyethylene groups varies around the chosen mean. These commercial preparations are adequate, and highly pure surfactants with a specific number of oxyethylene groups are not required.

The formula for this surfactant is $C_8H_{17}C_4H_9(CH_2CH_2O)_nOH$ (average $n=10$).

Synonyms include Octoxynol-10, PEG-10 octyl phenyl ether and POE (10) octyl phenyl ether

-24-

The HLB is 13.6, the melting point is 7°C, and the cloud point is 65°C.

Commercial preparations of this surfactant are available under various brand names. Suppliers and brand names are listed in the following table:

5

Trade name	Supplier
Akyporox OP100	Chem-Y GmbH
Alkasurf OP-10	Rhone-Poulenc Surfactants and Specialties
Dehydrophen POP 10	Pulcra SA
Hyonic OP-10	Henkel Corp.
Iconol OP-10	BASF Corp.
Igepal O	Rhone-Poulenc France
Macol OP-10	PPG Industries
Malorphen 810	Huls AG
Nikkol OP-10	Nikko Chem. Co. Ltd.
Renex 750	ICI Americas Inc.
Rexol 45/10	Hart Chemical Ltd.
Synperonic OP10	ICI PLC
Teric X10	ICI Australia

These are available in large volumes at low cost (less than one dollar per pound in quantity), and so contribute less than 10 cents per liter to prepared microemulsion ink with a 5% surfactant concentration.

10

Other suitable ethoxylated alkyl phenols include those listed in the following table:

Trivial name	Formula	HLB	Cloud point
Nonoxynol-9	$C_9H_{19}C_4H_9(CH_2CH_2O)_9OH$	13	54°C
Nonoxynol-10	$C_9H_{19}C_4H_9(CH_2CH_2O)_{10}OH$	13.2	62°C
Nonoxynol-11	$C_9H_{19}C_4H_9(CH_2CH_2O)_{11}OH$	13.8	72°C
Nonoxynol-12	$C_9H_{19}C_4H_9(CH_2CH_2O)_{12}OH$	14.5	81°C

-25-

Octoxynol-9	$C_8H_{17}C_4H_6(CH_2CH_2O)_9OH$	12.1	61°C
Octoxynol-10	$C_8H_{17}C_4H_6(CH_2CH_2O)_{10}OH$	13.6	65°C
Octoxynol-12	$C_8H_{17}C_4H_6(CH_2CH_2O)_{12}OH$	14.6	88°C
Dodoxynol-10	$C_{12}H_{25}C_4H_6(CH_2CH_2O)_{10}OH$	12.6	42°C
Dodoxynol-11	$C_{12}H_{25}C_4H_6(CH_2CH_2O)_{11}OH$	13.5	56°C
Dodoxynol-14	$C_{12}H_{25}C_4H_6(CH_2CH_2O)_{14}OH$	14.5	87°C

Microemulsion based inks have advantages other than surface tension control:

- 1) Microemulsions are thermodynamically stable, and will not separate.
- 5 Therefore, the storage time can be very long. This is especially significant for office and portable printers, which may be used sporadically.
- 2) The microemulsion will form spontaneously with a particular drop size, and does not require extensive stirring, centrifuging, or filtering to ensure a particular range of emulsified oil drop sizes.
- 10 3) The amount of oil contained in the ink can be quite high, so dyes which are soluble in oil or soluble in water, or both, can be used. It is also possible to use a mixture of dyes, one soluble in water, and the other soluble in oil, to obtain specific colors.
- 15 4) Oil miscible pigments are prevented from flocculating, as they are trapped in the oil microdroplets.
- 5) The use of a microemulsion can reduce the mixing of different dye colors on the surface of the print medium.
- 6) The viscosity of microemulsions is very low.
- 7) The requirement for humectants can be reduced or eliminated.

20 Dyes and pigments in microemulsion based inks

Oil in water mixtures can have high oil contents - as high as 40% - and still form O/W microemulsions. This allows a high dye or pigment loading.

-26-

Mixtures of dyes and pigments can be used. An example of a microemulsion based ink mixture with both dye and pigment is as follows:

- 1) 70% water
- 2) 5% water soluble dye
- 5 3) 5% surfactant
- 4) 10% oil
- 5) 10% oil miscible pigment

The following table shows the nine basic combinations of colorants in the oil and water phases of the microemulsion that may be used.

10

Combination	Colorant in water phase	Colorant in oil phase
1	none	oil miscible pigment
2	none	oil soluble dye
3	water soluble dye	none
4	water soluble dye	oil miscible pigment
5	water soluble dye	oil soluble dye
6	pigment dispersed in water	none
7	pigment dispersed in water	oil miscible pigment
8	pigment dispersed in water	oil soluble dye
9	none	none

The ninth combination, with no colorants, is useful for printing transparent coatings, UV ink, and selective gloss highlights.

15 As many dyes are amphiphilic, large quantities of dyes can also be solubilized in the oil-water boundary layer as this layer has a very large surface area.

It is also possible to have multiple dyes or pigments in each phase, and to have a mixture of dyes and pigments in each phase.

20 When using multiple dyes or pigments the absorption spectrum of the resultant ink will be the weighted average of the absorption spectra of the different colorants used. This presents two problems:

-27-

- 1) The absorption spectrum will tend to become broader, as the absorption peaks of both colorants are averaged. This has a tendency to 'muddy' the colors. To obtain brilliant color, careful choice of dyes and pigments based on their absorption spectra, not just their human-perceptible color, needs to be made.
- 5 2) The color of the ink may be different on different substrates. If a dye and a pigment are used in combination, the color of the dye will tend to have a smaller contribution to the printed ink color on more absorptive papers, as the dye will be absorbed into the paper, while the pigment will tend to 'sit on top' of the paper. This may be used as an advantage in some circumstances.

10 Surfactants with a Krafft point in the drop selection temperature range

For ionic surfactants there is a temperature (the Krafft point) below which the solubility is quite low, and the solution contains essentially no micelles. Above the Krafft temperature micelle formation becomes possible and there is a rapid increase in solubility of the surfactant. If the critical micelle concentration
15 (CMC) exceeds the solubility of a surfactant at a particular temperature, then the minimum surface tension will be achieved at the point of maximum solubility, rather than at the CMC. Surfactants are usually much less effective below the Krafft point.

This factor can be used to achieve an increased reduction in surface tension with increasing temperature. At ambient temperatures, only a portion of the
20 surfactant is in solution. When the nozzle heater is turned on, the temperature rises, and more of the surfactant goes into solution, decreasing the surface tension.

A surfactant should be chosen with a Krafft point which is near the top of the range of temperatures to which the ink is raised. This gives a maximum margin between the concentration of surfactant in solution at ambient temperatures,
25 and the concentration of surfactant in solution at the drop selection temperature.

The concentration of surfactant should be approximately equal to the CMC at the Krafft point. In this manner, the surface tension is reduced to the maximum amount at elevated temperatures, and is reduced to a minimum amount at ambient temperatures.

-28-

The following table shows some commercially available surfactants with Krafft points in the desired range.

Formula	Krafft point
$C_{16}H_{33}SO_3Na^+$	57°C
$C_{18}H_{37}SO_3Na^+$	70°C
$C_{16}H_{33}SO_4Na^+$	45°C
$Na^+O_4S(CH_2)_{16}SO_4Na^+$	44.9°C
$K^+O_4S(CH_2)_{16}SO_4K^+$	55°C
$C_{16}H_{33}CH(CH_3)C_4H_9SO_3Na^+$	60.8°C

Surfactants with a cloud point in the drop selection temperature range

- 5 Non-ionic surfactants using polyoxyethylene (POE) chains can be used to create an ink where the surface tension falls with increasing temperature. At low temperatures, the POE chain is hydrophilic, and maintains the surfactant in solution. As the temperature increases, the structured water around the POE section of the molecule is disrupted, and the POE section becomes hydrophobic. The surfactant is increasingly rejected by the water at higher temperatures, resulting in increasing concentration of surfactant at the air/ink interface, thereby lowering surface tension. The temperature at which the POE section of a nonionic surfactant becomes hydrophilic is related to the cloud point of that surfactant. POE chains by themselves are not particularly suitable, as the cloud point is generally above 100°C
- 10
- 15 Polyoxypropylene (POP) can be combined with POE in POE/POP block copolymers to lower the cloud point of POE chains without introducing a strong hydrophobicity at low temperatures.

Two main configurations of symmetrical POE/POP block copolymers are available. These are:

- 20 1) Surfactants with POE segments at the ends of the molecules, and a POP segment in the centre, such as the poloxamer class of surfactants (generically CAS 9003-11-6)

-29-

- 2) Surfactants with POP segments at the ends of the molecules, and a POE segment in the centre, such as the meroxapol class of surfactants (generically also CAS 9003-11-6)

- 5 Some commercially available varieties of poloxamer and meroxapol with a high surface tension at room temperature, combined with a cloud point above 40°C and below 100°C are shown in the following table:

Trivial name	BASF Trade name	Formula	Surface Tension (mN/m)	Cloud point
Merxapol 105	Pluronic 10R5	HO(CHCH ₃ CH ₂ O) _{.7-} (CH ₂ CH ₂ O) _{.22-} (CHCH ₃ CH ₂ O) _{.7} OH	50.9	69°C
Merxapol 108	Pluronic 10R8	HO(CHCH ₃ CH ₂ O) _{.7-} (CH ₂ CH ₂ O) _{.91-} (CHCH ₃ CH ₂ O) _{.7} OH	54.1	99°C
Merxapol 178	Pluronic 17R8	HO(CHCH ₃ CH ₂ O) _{.12-} (CH ₂ CH ₂ O) _{.136-} (CHCH ₃ CH ₂ O) _{.12} OH	47.3	81°C
Merxapol 258	Pluronic 25R8	HO(CHCH ₃ CH ₂ O) _{.18-} (CH ₂ CH ₂ O) _{.163-} (CHCH ₃ CH ₂ O) _{.18} OH	46.1	80°C
Poloxamer 105	Pluronic L35	HO(CH ₂ CH ₂ O) _{.11-} (CHCH ₃ CH ₂ O) _{.16-} (CH ₂ CH ₂ O) _{.11} OH	48.8	77°C
Poloxamer 124	Pluronic L44	HO(CH ₂ CH ₂ O) _{.11-} (CHCH ₃ CH ₂ O) _{.21-} (CH ₂ CH ₂ O) _{.11} OH	45.3	65°C

- 10 Other varieties of poloxamer and meroxapol can readily be synthesized using well known techniques. Desirable characteristics are a room

-30-

temperature surface tension which is as high as possible, and a cloud point between 40°C and 100°C, and preferably between 60°C and 80°C.

Merioxapol $[\text{HO}(\text{CHCH}_3\text{CH}_2\text{O})_x(\text{CH}_2\text{CH}_2\text{O})_y(\text{CHCH}_3\text{CH}_2\text{O})_z\text{OH}]$

varieties where the average x and z are approximately 4, and the average y is
5 approximately 15 may be suitable.

If salts are used to increase the electrical conductivity of the ink, then the effect of this salt on the cloud point of the surfactant should be considered.

The cloud point of POE surfactants is increased by ions that disrupt water structure (such as Γ^-), as this makes more water molecules available to form
10 hydrogen bonds with the POE oxygen lone pairs. The cloud point of POE surfactants is decreased by ions that form water structure (such as Cl^- , OH^-), as fewer water molecules are available to form hydrogen bonds. Bromide ions have relatively little effect. The ink composition can be 'tuned' for a desired temperature range by altering the lengths of POE and POP chains in a block copolymer
15 surfactant, and by changing the choice of salts (e.g Cl^- to Br^- to Γ^-) that are added to increase electrical conductivity. NaCl is likely to be the best choice of salts to increase ink conductivity, due to low cost and non-toxicity. NaCl slightly lowers the cloud point of nonionic surfactants.

Hot Melt Inks

20 The ink need not be in a liquid state at room temperature. Solid 'hot melt' inks can be used by heating the printing head and ink reservoir above the melting point of the ink. The hot melt ink must be formulated so that the surface tension of the molten ink decreases with temperature. A decrease of approximately 2 mN/m will be typical of many such preparations using waxes and other
25 substances. However, a reduction in surface tension of approximately 20 mN/m is desirable in order to achieve good operating margins when relying on a reduction in surface tension rather than a reduction in viscosity.

The temperature difference between quiescent temperature and drop selection temperature may be greater for a hot melt ink than for a water based ink,
30 as water based inks are constrained by the boiling point of the water.

-31-

The ink must be liquid at the quiescent temperature. The quiescent temperature should be higher than the highest ambient temperature likely to be encountered by the printed page. The quiescent temperature should also be as low as practical, to reduce the power needed to heat the print head, and to provide a maximum margin between the quiescent and the drop ejection temperatures. A quiescent temperature between 60°C and 90°C is generally suitable, though other temperatures may be used. A drop ejection temperature of between 160°C and 200°C is generally suitable.

There are several methods of achieving an enhanced reduction in surface tension with increasing temperature.

- 1) A dispersion of microfine particles of a surfactant with a melting point substantially above the quiescent temperature, but substantially below the drop ejection temperature, can be added to the hot melt ink while in the liquid phase.
- 2) A polar/non-polar microemulsion with a PIT which is preferably at least 20°C above the melting points of both the polar and non-polar compounds.

To achieve a large reduction in surface tension with temperature, it is desirable that the hot melt ink carrier have a relatively large surface tension (above 30 mN/m) when at the quiescent temperature. This generally excludes alkanes such as waxes. Suitable materials will generally have a strong intermolecular attraction, which may be achieved by multiple hydrogen bonds, for example, polyols, such as Hexanetetrol, which has a melting point of 88°C.

Surface tension reduction of various solutions

Figure 3(d) shows the measured effect of temperature on the surface tension of various aqueous preparations containing the following additives:

- 1) 0.1% sol of Stearic Acid
- 2) 0.1% sol of Palmitic acid
- 3) 0.1% solution of Pluronic 10R5 (trade mark of BASF)
- 4) 0.1% solution of Pluronic L35 (trade mark of BASF)
- 5) 0.1% solution of Pluronic L44 (trade mark of BASF)

-32-

Inks suitable for printing systems of the present invention are described in the following Australian patent specifications, the disclosure of which are hereby incorporated by reference:

5 'Ink composition based on a microemulsion' (Filing no.: PN5223, filed on 6 September 1995);

'Ink composition containing surfactant sol' (Filing no.: PN5224, filed on 6 September 1995);

'Ink composition for DOD printers with Krafft point near the drop selection temperature sol' (Filing no.: PN6240, filed on 30 October 1995); and

10 'Dye and pigment in a microemulsion based ink' (Filing no.: PN6241, filed on 30 October 1995).

Operation Using Reduction of Viscosity

As a second example, operation of an embodiment using thermal reduction of viscosity and proximity drop separation, in combination with hot melt ink, is as follows. Prior to operation of the printer, solid ink is melted in the reservoir 64. The reservoir, ink passage to the print head, ink channels 75, and print head 50 are maintained at a temperature at which the ink 100 is liquid, but exhibits a relatively high viscosity (for example, approximately 100 cP). The Ink 100 is retained in the nozzle by the surface tension of the ink. The ink 100 is formulated so that the viscosity of the ink reduces with increasing temperature. The ink pressure oscillates at a frequency which is an integral multiple of the drop ejection frequency from the nozzle. The ink pressure oscillation causes oscillations of the ink meniscus at the nozzle tips, but this oscillation is small due to the high ink viscosity. At the normal operating temperature, these oscillations are of insufficient amplitude to result in drop separation. When the heater 103 is energized, the ink forming the selected drop is heated, causing a reduction in viscosity to a value which is preferably less than 5 cP. The reduced viscosity results in the ink meniscus moving further during the high pressure part of the ink pressure cycle. The recording medium 51 is arranged sufficiently close to the print head 50 so that the selected drops contact the recording medium 51, but sufficiently far away that the unselected

15
20
25
30

-33-

drops do not contact the recording medium 51. Upon contact with the recording medium 51, part of the selected drop freezes, and attaches to the recording medium. As the ink pressure falls, ink begins to move back into the nozzle. The body of ink separates from the ink which is frozen onto the recording medium. The meniscus of the ink 100 at the nozzle tip then returns to low amplitude oscillation. The viscosity of the ink increases to its quiescent level as remaining heat is dissipated to the bulk ink and print head. One ink drop is selected, separated and forms a spot on the recording medium 51 for each heat pulse. As the heat pulses are electrically controlled, drop on demand ink jet operation can be achieved.

10 Manufacturing of Print Heads

Manufacturing processes for monolithic print heads in accordance with the present invention are described in the following Australian patent specifications filed on 12 April 1995, the disclosure of which are hereby incorporated by reference:

- 15 'A monolithic LIFT printing head' (Filing no.: PN2301);
'A manufacturing process for monolithic LIFT printing heads' (Filing no.: PN2302);
'A self-aligned heater design for LIFT print heads' (Filing no.: PN2303);
'Integrated four color LIFT print heads' (Filing no.: PN2304);
20 'Power requirement reduction in monolithic LIFT printing heads' (Filing no.: PN2305);
'A manufacturing process for monolithic LIFT print heads using anisotropic wet etching' (Filing no.: PN2306);
'Nozzle placement in monolithic drop-on-demand print heads' (Filing no.:
25 PN2307);
'Heater structure for monolithic LIFT print heads' (Filing no.: PN2346);
'Power supply connection for monolithic LIFT print heads' (Filing no.: PN2347);
30 'External connections for Proximity LIFT print heads' (Filing no.: PN2348); and

-34-

'A self-aligned manufacturing process for monolithic LIFT print heads'
(Filing no.: PN2349); and

'CMOS process compatible fabrication of LIFT print heads' (Filing no.:
PN5222, 6 September 1995).

5 'A manufacturing process for LIFT print heads with nozzle rim heaters'
(Filing no.: PN6238, 30 October 1995);

'A modular LIFT print head' (Filing no.: PN6237, 30 October 1995);

'Method of increasing packing density of printing nozzles' (Filing no.:
PN6236, 30 October 1995); and

10 'Nozzle dispersion for reduced electrostatic interaction between
simultaneously printed droplets' (Filing no.: PN6239, 30 October 1995).

Control of Print Heads

Means of providing page image data and controlling heater
temperature in print heads of the present invention is described in the following
15 Australian patent specifications filed on 12 April 1995, the disclosure of which are
hereby incorporated by reference:

'Integrated drive circuitry in LIFT print heads' (Filing no.: PN2295);

'A nozzle clearing procedure for Liquid Ink Fault Tolerant (LIFT)
printing' (Filing no.: PN2294);

20 'Heater power compensation for temperature in LIFT printing systems'
(Filing no.: PN2314);

'Heater power compensation for thermal lag in LIFT printing systems'
(Filing no.: PN2315);

25 'Heater power compensation for print density in LIFT printing systems'
(Filing no.: PN2316);

'Accurate control of temperature pulses in printing heads' (Filing no.:
PN2317);

'Data distribution in monolithic LIFT print heads' (Filing no.: PN2318);

30 'Page image and fault tolerance routing device for LIFT printing systems'
(Filing no.: PN2319); and

-35-

'A removable pressurized liquid ink cartridge for LIFT printers' (Filing no.: PN2320).

Image Processing for Print Heads

An objective of printing systems according to the invention is to
5 attain a print quality which is equal to that which people are accustomed to in
quality color publications printed using offset printing. This can be achieved using a
print resolution of approximately 1,600 dpi. However, 1,600 dpi printing is difficult
and expensive to achieve. Similar results can be achieved using 800 dpi printing,
with 2 bits per pixel for cyan and magenta, and one bit per pixel for yellow and
10 black. This color model is herein called CC'MM'YK. Where high quality
monochrome image printing is also required, two bits per pixel can also be used for
black. This color model is herein called CC'MM'YKK'. Color models, halftoning,
data compression, and real-time expansion systems suitable for use in systems of
this invention and other printing systems are described in the following Australian
15 patent specifications filed on 12 April 1995, the disclosure of which are hereby
incorporated by reference:

'Four level ink set for bi-level color printing' (Filing no.: PN2339);

'Compression system for page images' (Filing no.: PN2340);

20 'Real-time expansion apparatus for compressed page images' (Filing no.:
PN2341); and

'High capacity compressed document image storage for digital color
printers' (Filing no.: PN2342);

'Improving JPEG compression in the presence of text' (Filing no.:
PN2343);

25 'An expansion and halftoning device for compressed page images' (Filing
no.: PN2344); and

'Improvements in image halftoning' (Filing no.: PN2345).

-36-

Applications Using Print Heads According to this Invention

Printing apparatus and methods of this invention are suitable for a wide range of applications, including (but not limited to) the following: color and monochrome office printing, short run digital printing, high speed digital printing, process color printing, spot color printing, offset press supplemental printing, low cost printers using scanning print heads, high speed printers using pagewidth print heads, portable color and monochrome printers, color and monochrome copiers, color and monochrome facsimile machines, combined printer, facsimile and copying machines, label printing, large format plotters, photographic duplication, printers for digital photographic processing, portable printers incorporated into digital 'instant' cameras, video printing, printing of PhotoCD images, portable printers for 'Personal Digital Assistants', wallpaper printing, indoor sign printing, billboard printing, and fabric printing.

Printing systems based on this invention are described in the following Australian patent specifications filed on 12 April 1995, the disclosure of which are hereby incorporated by reference:

'A high speed color office printer with a high capacity digital page image store' (Filing no.: PN2329);

'A short run digital color printer with a high capacity digital page image store' (Filing no.: PN2330);

'A digital color printing press using LIFT printing technology' (Filing no.: PN2331);

'A modular digital printing press' (Filing no.: PN2332);

'A high speed digital fabric printer' (Filing no.: PN2333);

'A color photograph copying system' (Filing no.: PN2334);

'A high speed color photocopier using a LIFT printing system' (Filing no.: PN2335);

'A portable color photocopier using LIFT printing technology' (Filing no.: PN2336);

'A photograph processing system using LIFT printing technology' (Filing no.: PN2337);

-37-

'A plain paper facsimile machine using a LIFT printing system' (Filing no.: PN2338);

'A PhotoCD system with integrated printer' (Filing no.: PN2293);

'A color plotter using LIFT printing technology' (Filing no.: PN2291);

5 'A notebook computer with integrated LIFT color printing system' (Filing no.: PN2292);

'A portable printer using a LIFT printing system' (Filing no.: PN2300);

'Fax machine with on-line database interrogation and customized magazine printing' (Filing no.: PN2299);

10 'Miniature portable color printer' (Filing no.: PN2298);

'A color video printer using a LIFT printing system' (Filing no.: PN2296);

and

'An integrated printer, copier, scanner, and facsimile using a LIFT printing system' (Filing no.: PN2297)

15 Compensation of Print Heads for Environmental Conditions

It is desirable that drop on demand printing systems have consistent and predictable ink drop size and position. Unwanted variation in ink drop size and position causes variations in the optical density of the resultant print, reducing the perceived print quality. These variations should be kept to a small proportion of the nominal ink drop volume and pixel spacing respectively. Many environmental variables can be compensated to reduce their effect to insignificant levels. Active compensation of some factors can be achieved by varying the power applied to the nozzle heaters.

25 An optimum temperature profile for one print head embodiment involves an instantaneous raising of the active region of the nozzle tip to the ejection temperature, maintenance of this region at the ejection temperature for the duration of the pulse, and instantaneous cooling of the region to the ambient temperature.

30 This optimum is not achievable due to the stored heat capacities and thermal conductivities of the various materials used in the fabrication of the nozzles

in accordance with the invention. However, improved performance can be achieved by shaping the power pulse using curves which can be derived by iterative refinement of finite element simulation of the print head. The power applied to the heater can be varied in time by various techniques, including, but not limited to:

- 5 1) Varying the voltage applied to the heater
- 2) Modulating the width of a series of short pulses (PWM)
- 3) Modulating the frequency of a series of short pulses (PFM)

To obtain accurate results, a transient fluid dynamic simulation with free surface modeling is required, as convection in the ink, and ink flow,
 10 significantly affect on the temperature achieved with a specific power curve.

By the incorporation of appropriate digital circuitry on the print head substrate, it is practical to individually control the power applied to each nozzle. One way to achieve this is by 'broadcasting' a variety of different digital pulse trains across the print head chip, and selecting the appropriate pulse train for each nozzle
 15 using multiplexing circuits.

An example of the environmental factors which may be compensated for is listed in the table "Compensation for environmental factors". This table identifies which environmental factors are best compensated globally (for the entire print head), per chip (for each chip in a composite multi-chip print head), and per
 20 nozzle.

Compensation for environmental factors

Factor compensated	Scope	Sensing or user control method	Compensation mechanism
Ambient Temperature	Global	Temperature sensor mounted on print head	Power supply voltage or global PFM patterns
Power supply voltage fluctuation with number of active nozzles	Global	Predictive active nozzle count based on print data	Power supply voltage or global PFM patterns
Local heat build-up with successive nozzle actuation	Per nozzle	Predictive active nozzle count based on print data	Selection of appropriate PFM pattern for each printed drop

Drop size control for multiple bits per pixel	Per nozzle	Image data	Selection of appropriate PFM pattern for each printed drop
Nozzle geometry variations between wafers	Per chip	Factory measurement, datafile supplied with print head	Global PFM patterns per print head chip
Heater resistivity variations between wafers	Per chip	Factory measurement, datafile supplied with print head	Global PFM patterns per print head chip
User image intensity adjustment	Global	User selection	Power supply voltage, electrostatic acceleration voltage, or ink pressure
Ink surface tension reduction method and threshold temperature	Global	Ink cartridge sensor or user selection	Global PFM patterns
Ink viscosity	Global	Ink cartridge sensor or user selection	Global PFM patterns and/or clock rate
Ink dye or pigment concentration	Global	Ink cartridge sensor or user selection	Global PFM patterns
Ink response time	Global	Ink cartridge sensor or user selection	Global PFM patterns

Most applications will not require compensation for all of these variables. Some variables have a minor effect, and compensation is only necessary where very high image quality is required.

5 Print head drive circuits

Figure 4 is a block schematic diagram showing electronic operation of an example head driver circuit in accordance with this invention. This control circuit uses analog modulation of the power supply voltage applied to the print head to achieve heater power modulation, and does not have individual control of the power applied to each nozzle. Figure 4 shows a block diagram for a system using an
 10 800 dpi pagewidth print head which prints process color using the CC'MM'YK

-40-

color model. The print head 50 has a total of 79,488 nozzles, with 39,744 main nozzles and 39,744 redundant nozzles. The main and redundant nozzles are divided into six colors, and each color is divided into 8 drive phases. Each drive phase has a shift register which converts the serial data from a head control ASIC 400 into parallel data for enabling heater drive circuits. There is a total of 96 shift registers, each providing data for 828 nozzles. Each shift register is composed of 828 shift register stages 217, the outputs of which are logically anded with phase enable signal by a nand gate 215. The output of the nand gate 215 drives an inverting buffer 216, which in turn controls the drive transistor 201. The drive transistor 201 actuates the electrothermal heater 200, which may be a heater 103 as shown in figure 1(b). To maintain the shifted data valid during the enable pulse, the clock to the shift register is stopped the enable pulse is active by a clock stopper 218, which is shown as a single gate for clarity, but is preferably any of a range of well known glitch free clock control circuits. Stopping the clock of the shift register removes the requirement for a parallel data latch in the print head, but adds some complexity to the control circuits in the Head Control ASIC 400. Data is routed to either the main nozzles or the redundant nozzles by the data router 219 depending on the state of the appropriate signal of the fault status bus.

The print head shown in figure 4 is simplified, and does not show various means of improving manufacturing yield, such as block fault tolerance. Drive circuits for different configurations of print head can readily be derived from the apparatus disclosed herein.

Digital information representing patterns of dots to be printed on the recording medium is stored in the Page or Band memory 1513, which may be the same as the Image memory 72 in figure 1(a). Data in 32 bit words representing dots of one color is read from the Page or Band memory 1513 using addresses selected by the address mux 417 and control signals generated by the Memory Interface 418. These addresses are generated by Address generators 411, which forms part of the 'Per color circuits' 410, for which there is one for each of the six color components. The addresses are generated based on the positions of the nozzles in relation to the

-41-

print medium. As the relative position of the nozzles may be different for different print heads, the Address generators 411 are preferably made programmable. The Address generators 411 normally generate the address corresponding to the position of the main nozzles. However, when faulty nozzles are present, locations of blocks of nozzles containing faults can be marked in the Fault Map RAM 412. The Fault Map RAM 412 is read as the page is printed. If the memory indicates a fault in the block of nozzles, the address is altered so that the Address generators 411 generate the address corresponding to the position of the redundant nozzles. Data read from the Page or Band memory 1513 is latched by the latch 413 and converted to four sequential bytes by the multiplexer 414. Timing of these bytes is adjusted to match that of data representing other colors by the FIFO 415. This data is then buffered by the buffer 430 to form the 48 bit main data bus to the print head 50. The data is buffered as the print head may be located a relatively long distance from the head control ASIC. Data from the Fault Map RAM 412 also forms the input to the FIFO 416. The timing of this data is matched to the data output of the FIFO 415, and buffered by the buffer 431 to form the fault status bus.

The programmable power supply 320 provides power for the head 50. The voltage of the power supply 320 is controlled by the DAC 313, which is part of a RAM and DAC combination (RAMDAC) 316. The RAMDAC 316 contains a dual port RAM 317. The contents of the dual port RAM 317 are programmed by the Microcontroller 315. Temperature is compensated by changing the contents of the dual port RAM 317. These values are calculated by the microcontroller 315 based on temperature sensed by a thermal sensor 300. The thermal sensor 300 signal connects to the Analog to Digital Converter (ADC) 311. The ADC 311 is preferably incorporated in the Microcontroller 315.

The Head Control ASIC 400 contains control circuits for thermal lag compensation and print density. Thermal lag compensation requires that the power supply voltage to the head 50 is a rapidly time-varying voltage which is synchronized with the enable pulse for the heater. This is achieved by programming the programmable power supply 320 to produce this voltage. An analog time

-42-

varying programming voltage is produced by the DAC 313 based upon data read from the dual port RAM 317. The data is read according to an address produced by the counter 403. The counter 403 produces one complete cycle of addresses during the period of one enable pulse. This synchronization is ensured, as the counter 403 is clocked by the system clock 408, and the top count of the counter 403 is used to clock the enable counter 404. The count from the enable counter 404 is then decoded by the decoder 405 and buffered by the buffer 432 to produce the enable pulses for the head 50. The counter 403 may include a prescaler if the number of states in the count is less than the number of clock periods in one enable pulse.

5

10 Sixteen voltage states are adequate to accurately compensate for the heater thermal lag. These sixteen states can be specified by using a four bit connection between the counter 403 and the dual port RAM 317. However, these sixteen states may not be linearly spaced in time. To allow non-linear timing of these states the counter 403 may also include a ROM or other device which causes the counter 403 to count in a non-linear fashion. Alternatively, fewer than sixteen states may be used.

15

For print density compensation, the printing density is detected by counting the number of pixels to which a drop is to be printed ('on' pixels) in each enable period. The 'on' pixels are counted by the On pixel counters 402. There is one On pixel counter 402 for each of the eight enable phases. The number of enable phases in a print head in accordance with the invention depend upon the specific design. Four, eight, and sixteen are convenient numbers, though there is no requirement that the number of enable phases is a power of two. The On Pixel Counters 402 can be composed of combinatorial logic pixel counters 420 which determine how many bits in a nibble of data are on. This number is then accumulated by the adder 421 and accumulator 422. A latch 423 holds the accumulated value valid for the duration of the enable pulse. The multiplexer 401 selects the output of the latch 423 which corresponds to the current enable phase, as determined by the enable counter 404. The output of the multiplexer 401 forms part of the address of the dual port RAM 317. An exact count of the number of 'on' pixels is not necessary, and the most significant four bits of this count are adequate.

20

25

30

-43-

Combining the four bits of thermal lag compensation address and the four bits of print density compensation address means that the dual port RAM 317 has an 8 bit address. This means that the dual port RAM 317 contains 256 numbers, which are in a two dimensional array. These two dimensions are time (for thermal lag compensation) and print density. A third dimension - temperature - can be included. As the ambient temperature of the head varies only slowly, the microcontroller 315 has sufficient time to calculate a matrix of 256 numbers compensating for thermal lag and print density at the current temperature. Periodically (for example, a few times a second), the microcontroller senses the current head temperature and calculates this matrix.

The clock to the print head 50 is generated from the system clock 408 by the Head clock generator 407, and buffered by the buffer 406. To facilitate testing of the Head control ASIC, JTAG test circuits 499 may be included.

Comparison with thermal ink jet technology

The table "Comparison between Thermal ink jet and Present Invention" compares the aspects of printing in accordance with the present invention with thermal ink jet printing technology.

A direct comparison is made between the present invention and thermal ink jet technology because both are drop on demand systems which operate using thermal actuators and liquid ink. Although they may appear similar, the two technologies operate on different principles.

Thermal ink jet printers use the following fundamental operating principle. A thermal impulse caused by electrical resistance heating results in the explosive formation of a bubble in liquid ink. Rapid and consistent bubble formation can be achieved by superheating the ink, so that sufficient heat is transferred to the ink before bubble nucleation is complete. For water based ink, ink temperatures of approximately 280°C to 400°C are required. The bubble formation causes a pressure wave which forces a drop of ink from the aperture with high velocity. The bubble then collapses, drawing ink from the ink reservoir to re-fill the nozzle.

Thermal ink jet printing has been highly successful commercially due to the high

-44-

nozzle packing density and the use of well established integrated circuit manufacturing techniques. However, thermal ink jet printing technology faces significant technical problems including multi-part precision fabrication, device yield, image resolution, 'pepper' noise, printing speed, drive transistor power, waste power dissipation, satellite drop formation, thermal stress, differential thermal expansion, kogation, cavitation, rectified diffusion, and difficulties in ink formulation.

Printing in accordance with the present invention has many of the advantages of thermal ink jet printing, and completely or substantially eliminates many of the inherent problems of thermal ink jet technology.

Comparison between Thermal ink jet and Present Invention

	Thermal Ink-Jet	Present Invention
Drop selection mechanism	Drop ejected by pressure wave caused by thermally induced bubble	Choice of surface tension or viscosity reduction mechanisms
Drop separation mechanism	Same as drop selection mechanism	Choice of proximity, electrostatic, magnetic, and other methods
Basic ink carrier	Water	Water, microemulsion, alcohol, glycol, or hot melt
Head construction	Precision assembly of nozzle plate, ink channel, and substrate	Monolithic
Per copy printing cost	Very high due to limited print head life and expensive inks	Can be low due to permanent print heads and wide range of possible inks
Satellite drop formation	Significant problem which degrades image quality	No satellite drop formation
Operating ink temperature	280°C to 400°C (high temperature limits dye use and ink formulation)	Approx. 70°C (depends upon ink formulation)
Peak heater temperature	400°C to 1,000°C (high temperature reduces device life)	Approx. 130°C

-45-

Cavitation (heater erosion by bubble collapse)	Serious problem limiting head life	None (no bubbles are formed)
Kogation (coating of heater by ink ash)	Serious problem limiting head life and ink formulation	None (water based ink temperature does not exceed 100°C)
Rectified diffusion (formation of ink bubbles due to pressure cycles)	Serious problem limiting ink formulation	Does not occur as the ink pressure does not go negative
Resonance	Serious problem limiting nozzle design and repetition rate	Very small effect as pressure waves are small
Practical resolution	Approx. 800 dpi max.	Approx. 1,600 dpi max.
Self-cooling operation	No (high energy required)	Yes: printed ink carries away drop selection energy
Drop ejection velocity	High (approx. 10 m/sec)	Low (approx. 1 m/sec)
Crosstalk	Serious problem requiring careful acoustic design, which limits nozzle refill rate.	Low velocities and pressures associated with drop ejection make crosstalk very small.
Operating thermal stress	Serious problem limiting print-head life.	Low: maximum temperature increase approx. 90°C at centre of heater.
Manufacturing thermal stress	Serious problem limiting print-head size.	Same as standard CMOS manufacturing process.
Drop selection energy	Approx. 20 μ J	Approx. 270 nJ
Heater pulse period	Approx. 2-3 μ s	Approx. 15-30 μ s
Average heater pulse power	Approx. 8 Watts per heater.	Approx. 12 mW per heater. This is more than 500 times less than Thermal Ink-Jet.
Heater pulse voltage	Typically approx. 40V.	Approx. 5 to 10V.
Heater peak pulse current	Typically approx. 200 mA per heater. This requires bipolar or very large MOS drive transistors.	Approx. 4 mA per heater. This allows the use of small MOS drive transistors.

-46-

Fault tolerance	Not implemented. Not practical for edge shooter type.	Simple implementation results in better yield and reliability
Constraints on ink composition	Many constraints including kogation, nucleation, etc.	Temperature coefficient of surface tension or viscosity must be negative.
Ink pressure	Atmospheric pressure or less	Approx. 1.1 atm
Integrated drive circuitry	Bipolar circuitry usually required due to high drive current	CMOS, nMOS, or bipolar
Differential thermal expansion	Significant problem for large print heads	Monolithic construction reduces problem
Pagewidth print heads	Major problems with yield, cost, precision construction, head life, and power dissipation	High yield, low cost and long life due to fault tolerance. Self cooling due to low power dissipation.

Yield and Fault Tolerance

In most cases, monolithic integrated circuits cannot be repaired if they are not completely functional when manufactured. The percentage of operational devices which are produced from a wafer run is known as the yield. Yield has a direct influence on manufacturing cost. A device with a yield of 5% is effectively ten times more expensive to manufacture than an identical device with a yield of 50%.

There are three major yield measurements:

- 1) Fab yield
- 2) Wafer sort yield
- 3) Final test yield

For large die, it is typically the wafer sort yield which is the most serious limitation on total yield. Full pagewidth color heads in accordance with this invention are very large in comparison with typical VLSI circuits. Good wafer sort yield is critical to the cost-effective manufacture of such heads.

-47-

Figure 5 is a graph of wafer sort yield versus defect density for a monolithic full width color A4 head embodiment of the invention. The head is 215 mm long by 5 mm wide. The non fault tolerant yield 198 is calculated according to Murphy's method, which is a widely used yield prediction method. With a defect
5 density of one defect per square cm, Murphy's method predicts a yield less than 1%. This means that more than 99% of heads fabricated would have to be discarded. This low yield is highly undesirable, as the print head manufacturing cost becomes unacceptably high.

Murphy's method approximates the effect of an uneven distribution
10 of defects. Figure 5 also includes a graph of non fault tolerant yield 197 which explicitly models the clustering of defects by introducing a defect clustering factor. The defect clustering factor is not a controllable parameter in manufacturing, but is a characteristic of the manufacturing process. The defect clustering factor for manufacturing processes can be expected to be approximately 2, in which case yield
15 projections closely match Murphy's method.

A solution to the problem of low yield is to incorporate fault tolerance by including redundant functional units on the chip which are used to replace faulty functional units.

In memory chips and most Wafer Scale Integration (WSI) devices,
20 the physical location of redundant sub-units on the chip is not important. However, in printing heads the redundant sub-unit may contain one or more printing actuators. These must have a fixed spatial relationship to the page being printed. To be able to print a dot in the same position as a faulty actuator, redundant actuators must not be displaced in the non-scan direction. However, faulty actuators can be
25 replaced with redundant actuators which are displaced in the scan direction. To ensure that the redundant actuator prints the dot in the same position as the faulty actuator, the data timing to the redundant actuator can be altered to compensate for the displacement in the scan direction.

To allow replacement of all nozzles, there must be a complete set of
30 spare nozzles, which results in 100% redundancy. The requirement for 100%

-48-

redundancy would normally more than double the chip area, dramatically reducing the primary yield before substituting redundant units, and thus eliminating most of the advantages of fault tolerance.

However, with print head embodiments according to this invention,
5 the minimum physical dimensions of the head chip are determined by the width of the page being printed, the fragility of the head chip, and manufacturing constraints on fabrication of ink channels which supply ink to the back surface of the chip. The minimum practical size for a full width, full color head for printing A4 size paper is approximately 215 mm x 5 mm. This size allows the inclusion of 100% redundancy
10 without significantly increasing chip area, when using 1.5 μm CMOS fabrication technology. Therefore, a high level of fault tolerance can be included without significantly decreasing primary yield.

When fault tolerance is included in a device, standard yield equations cannot be used. Instead, the mechanisms and degree of fault tolerance must be
15 specifically analyzed and included in the yield equation. Figure 5 shows the fault tolerant sort yield 199 for a full width color A4 head which includes various forms of fault tolerance, the modeling of which has been included in the yield equation. This graph shows projected yield as a function of both defect density and defect clustering. The yield projection shown in figure 5 indicates that thoroughly
20 implemented fault tolerance can increase wafer sort yield from under 1% to more than 90% under identical manufacturing conditions. This can reduce the manufacturing cost by a factor of 100.

Fault tolerance is highly recommended to improve yield and reliability of print heads containing thousands of printing nozzles, and thereby make
25 pagewidth printing heads practical. However, fault tolerance is not to be taken as an essential part of the present invention.

Fault tolerance in drop-on-demand printing systems is described in the following Australian patent specifications filed on 12 April 1995, the disclosure of which are hereby incorporated by reference:

30 'Integrated fault tolerance in printing mechanisms' (Filing no.: PN2324);

-49-

'Block fault tolerance in integrated printing heads' (Filing no.: PN2325);

'Nozzle duplication for fault tolerance in integrated printing heads' (Filing no.: PN2326);

'Detection of faulty nozzles in printing heads' (Filing no.: PN2327); and

5 'Fault tolerance in high volume printing presses' (Filing no.: PN2328).

Printing System Embodiments

A schematic diagram of a digital electronic printing system using a print head of this invention is shown in Figure 6. This shows a monolithic printing head 50 printing an image 60 composed of a multitude of ink drops onto a recording medium 51. This medium will typically be paper, but can also be overhead transparency film, cloth, or many other substantially flat surfaces which will accept ink drops. The image to be printed is provided by an image source 52, which may be any image type which can be converted into a two dimensional array of pixels. Typical image sources are image scanners, digitally stored images, images encoded in a page description language (PDL) such as Adobe Postscript, Adobe Postscript level 2, or Hewlett-Packard PCL 5, page images generated by a procedure-call based rasterizer, such as Apple QuickDraw, Apple Quickdraw GX, or Microsoft GDI, or text in an electronic form such as ASCII. This image data is then converted by an image processing system 53 into a two dimensional array of pixels suitable for the particular printing system. This may be color or monochrome, and the data will typically have between 1 and 32 bits per pixel, depending upon the image source and the specifications of the printing system. The image processing system may be a raster image processor (RIP) if the source image is a page description, or may be a two dimensional image processing system if the source image is from a scanner.

25 If continuous tone images are required, then a halftoning system 54 is necessary. Suitable types of halftoning are based on *dispersed dot ordered dither* or *error diffusion*. Variations of these, commonly known as *stochastic screening* or *frequency modulation screening* are suitable. The halftoning system commonly used for offset printing - *clustered dot ordered dither* - is not recommended, as effective image resolution is unnecessarily wasted using this technique. The output of the

30

-50-

halftoning system is a binary monochrome or color image at the resolution of the printing system according to the present invention.

The binary image is processed by a data phasing circuit 55 (which may be incorporated in a Head Control ASIC 400 as shown in figure 4) which provides the pixel data in the correct sequence to the data shift registers 56. Data sequencing is required to compensate for the nozzle arrangement and the movement of the paper. When the data has been loaded into the shift registers 56, it is presented in parallel to the heater driver circuits 57. At the correct time, the driver circuits 57 will electronically connect the corresponding heaters 58 with the voltage pulse generated by the pulse shaper circuit 61 and the voltage regulator 62. The heaters 58 heat the tip of the nozzles 59, affecting the physical characteristics of the ink. Ink drops 60 escape from the nozzles in a pattern which corresponds to the digital impulses which have been applied to the heater driver circuits. The pressure of the ink in the ink reservoir 64 is regulated by the pressure regulator 63. Selected drops of ink drops 60 are separated from the body of ink by the chosen drop separation means, and contact the recording medium 51. During printing, the recording medium 51 is continually moved relative to the print head 50 by the paper transport system 65. If the print head 50 is the full width of the print region of the recording medium 51, it is only necessary to move the recording medium 51 in one direction, and the print head 50 can remain fixed. If a smaller print head 50 is used, it is necessary to implement a raster scan system. This is typically achieved by scanning the print head 50 along the short dimension of the recording medium 51, while moving the recording medium 51 along its long dimension.

The foregoing describes one embodiment of the present invention. Modifications, obvious to those skilled in the art, can be made thereto without departing from the scope of the invention.

Multiple nozzles in a single monolithic print head

It is desirable that a new printing system intended for use in equipment such as office printers or photocopiers is able to print quickly. A printing speed of 60 A4 pages per minute (one page per second) will generally be adequate

-51-

for many applications. However, achieving an electronically controlled print speed of 60 pages per minute is not simple.

The minimum time taken to print a page is equal to the number of dot positions on the page times the time required to print a dot, divided by the
5 number of dots of each color which can be printed simultaneously.

The image quality that can be obtained is affected by the total number of ink dots which can be used to create an image. For full color magazine quality printing using dispersed dot digital halftoning, approximately 800 dots per inch (31.5 dots per mm) are required. The spacing between dots on the paper is
10 31.75 μm .

A standard A4 page is 210 mm times 297 mm. At 31.5 dots per mm, 61,886,632 dots are required for a monochrome full bleed A4 page. High quality process color printing requires four colors - cyan, magenta, yellow, and black. Therefore, the total number of dots required is 247,546,528. While this can be
15 reduced somewhat by not allowing printing in a small margin at the edge of the paper, the total number of dots required is still very large. If the time taken to print a dot is 144 ms, and only one nozzle per color is provided, then it will take more than two hours to print a single page.

To achieve high speed, high quality printing with my printing system
20 described above, printing heads with many small nozzles are preferred. The printing of a 800 dpi color A4 page in one second can be achieved if the printing head is the full width of the paper. The printing head can be stationary, and the paper can travel past it in the one second period. A four color 800 dpi printing head 210 mm wide requires 26,460 nozzles.

25 Such a print head may contain 26,460 active nozzles, and 26,460 redundant (spare) nozzles, giving a total of 52,920 nozzles. There are 6,615 active nozzles for each of the cyan, magenta, yellow, and black process colors.

Print heads with large numbers of nozzles can be manufactured at low cost. This can be achieved by using semiconductor manufacturing processes to
30 simultaneously fabricate many thousands of nozzles in a silicon wafer. To eliminate

-52-

problems with mechanical alignment and differential thermal expansion that would occur if the print head were to be manufactured in several parts and assembled, the head can be manufactured from a single piece of silicon. Nozzles and ink channels are etched into the silicon. Heater elements are formed by evaporation of resistive materials, and subsequent photolithography using standard semiconductor manufacturing processes.

To reduce the large number of connections that would be required on a print head with thousands of nozzles, data distribution circuits and drive circuits can also be integrated on the print head.

Figure 7 is a simplified view of a portion of a print head, seen from the back surface of the chip, and cut through some of the nozzles. The substrate 120 can be made from a single silicon crystal. Nozzles 121 are fabricated in the substrate, e.g., by semiconductor photolithography and chemical wet etch or plasma etching processes. Ink enters the nozzle at the top surface of the head, passes through the substrate, and leaves via the nozzle tip 123. Planar fabrication of the heaters and the drive circuitry is on the underside of the wafer; that is, the print head is shown 'upside down' in relation the surface upon which active circuitry is fabricated. The substrate thickness 124 can be that of a standard silicon wafer, approximately 650 μm . The head width 125 is related to the number of colors, the arrangement of nozzles, the spacing between the nozzles, and the head area required for drive circuitry and interconnections. For a monochrome head, an appropriate width would be approximately 2 mm. For a process color head, an appropriate width would be approximately 5 mm. For a CC'MM'YK color print head, the appropriate head width is approximately 8 mm. The length of the head 126 depends upon the application. Very low cost applications may use short heads, which must be scanned over a page. High speed applications can use fixed page-width monolithic or multi-chip print heads. A typical range of lengths for print heads is between 1 cm and 21 cm, though print heads longer than 21 cm are appropriate for high volume paper or fabric printing.

-53-

Self-aligned print head manufacturing using anisotropic wet etches

The manufacture of monolithic printing heads is similar to standard silicon integrated circuit manufacture. However, the normal process flow are modified in several ways. This is essential to form the nozzles, the barrels for the nozzles, the heaters, and the nozzle tips. There are many different semiconductor processes upon which monolithic head production can be based. For each of these semiconductor processes, there are many different ways the basic process can be modified to form the necessary structures.

To reduce the cost of establishing factories to produce heads, it is desirable to base the production on a simple process. It is also desirable to use a set of design rules which is as coarse as practical. This is because equipment to produce fine line widths is more expensive, and requires a cleaner environment to achieve equivalent yields.

To minimize the capital cost of small volume manufacturing runs it is desirable that the additional processing steps needed to form the nozzles can be achieved with low capital investment. This patent describes a manufacturing process where nozzle formation is achieved mainly using anisotropic wet etch processes. As a result, expensive plasma etching equipment is not required.

The process described herein is based on standard semiconductor manufacturing processes, and can use equipment designed for 1.5 μm line widths. The use of lithographic equipment which is essentially obsolete (at the time of writing, the latest production IC manufacturing equipment is capable of 0.25 μm line widths) can substantially reduce the cost of establishing factories for the production of heads.

It is also not necessary to use a low power, high speed process such as VLSI CMOS. The speeds required are moderate, and the power consumption is dominated by the heater power required for the ink jet nozzles. Therefore, a simple technology such as nMOS is adequate. However, CMOS is likely to be the most practical production solution, as there is a significant amount of idle CMOS manufacturing capability available with line widths between 1 μm and 2 μm .

-54-

Suitable basic manufacturing processes

The manufacturing steps required for fabricating nozzles can be incorporated into many different semiconductor processing systems. For example, it is possible to manufacture print heads by modifying the following technologies:

- 5 1) nMOS
- 2) pMOS
- 3) CMOS
- 4) Bipolar
- 5) ECL
- 10 6) Various gallium arsenide processes
- 7) Thin Film Transistors (TFT) on glass substrates
- 8) Micromechanical fabrication without active semiconductor circuits

The choice of the base technology is largely independent of the ability to fabricate nozzles. The method of incorporation of nozzle manufacturing steps into semiconductor processing procedures which have not yet been invented is also likely to be obvious to those skilled in the art. The simplest fabrication process is to manufacture the nozzles using silicon micromechanical processing, without fabricating active semiconductor devices on the same wafer. However, this approach is not practical for heads with large numbers of nozzles, as at least one external connection to the head is required for each nozzle. For large heads, it is highly advantageous to fabricate drive transistors and data distribution circuits on the same chip as the nozzles.

CMOS is currently the most popular integrated circuit process. At present, many CMOS processes are in commercial use, with line widths as small as 0.35 μm being in common use. CMOS offers the following advantages for the fabrication of heads:

- 1) Well known and well characterized production process.
- 2) Quiescent current is almost zero
- 3) High reliability
- 30 4) High noise immunity
- 5) Wide power supply operating range

-55-

- 6) Reduced electromigration in metal lines
- 7) Simpler circuit design of shift registers and fault tolerance logic
- 8) The substrate can be grounded from the front side of the wafer.

CMOS has, however, some disadvantages over nMOS and other
5 technologies in the fabrication of heads which include integrated drive circuitry.

These include:

- 1) A large number of processing steps are required to simultaneously manufacture high quality NMOS and PMOS devices on the same chip.
- 2) CMOS is susceptible to latchup. This is of particular concern due to the high
10 currents at a voltage typically greater than V_{dd} that are required for the heater circuits.
- 3) Like other MOS technologies, CMOS is susceptible to electrostatic discharge damage. This can be minimized by including protection circuits at the inputs, and by careful handling.

15 There is no absolute 'best' base manufacturing process which is applicable to all possible configurations of printing head. Instead, the manufacturing steps which are specific to the nozzles should be incorporated into the manufacturer's preferred process. In most cases, there will need to be minor alterations to the specific details of nozzle manufacturing steps to be compatible
20 with the existing process flow, equipment used, preferred photoresists, and preferred chemical processes. These modifications are obvious to those skilled in the art, and can be made without departing from the scope of the invention.

Layout example

Figure 8(a) shows an example layout for a section of an 800 dpi four
25 color head. The nozzle pitch for 800 dpi printing is $31.75 \mu\text{m}$. Figure 8(a) shows four rows of nozzles, for cyan, magenta, yellow, and black inks. Each of these four rows contains four parallel ink channels. The ink channels are etched almost through the wafer and each contains 64 nozzles. Two ink channels are for the main nozzles, and two ink channels are for the redundant nozzles. The nozzles are spaced
30 by two pixel widths ($63.5 \mu\text{m}$) along each ink channel. The nozzles in one of the

-56-

two main ink channels for each color are offset by one pixel width (31.75 μm) from the nozzles in the other main ink channel. The redundant nozzles are arranged in an identical manner, but offset in the print direction. The ink channels do not extend the entire length of the print region of the print head, as this would mechanically weaken the print head too much. Instead, ink channels containing 64 nozzles are staggered in the print direction. Using a staggered array of nozzles such as this requires that the data be provided to drive the nozzles in such a manner as to compensate for the nozzle offsets. This can be achieved by digital circuitry which reads the page image from memory in the appropriate order and supplies the data to the print head.

Rectangular regions 100 μm wide and 200 μm long are shown along the short edge chip layout. These are bonding pads for data, clocks, and logic power and ground. The V^+ and V^- bonding pads extend along the entire two long edges of the chip, and are 200 μm wide.

Figure 8(b) is a detail enlargement of the ink channels and nozzles for one color of the print head shown in figure 8(a). The distance 4,064 μm is 64 times the nozzle spacing in a channel (63.5 μm). The distance 8,128 μm is 128 times the nozzle spacing in a channel. The distance 6790.6 μm is 4064 μm plus 2 * (1260 μm + (50 μm / $\tan 70.52^\circ$) + (50 μm / $\tan 54.74^\circ$) + 50 μm tolerance). The 50 μm tolerance is required because the wafer thickness may vary by as much as 25 μm .

Figure 8(c) is a detail enlargement of the end of a single ink channel. The angles shown are due to the anisotropic etching process, and result from the orientation of the {111} crystallographic planes. The distance from full wafer thickness to the point at the bottom of the ink channel is 1260 μm . This results from a (111) crystallographic plane which is at an angle of $\tan^{-1}(0.5) = 26.57^\circ$ to the wafer surface. To achieve a required etch depth of 630 μm , an extra length of 1260 μm must be provided at the ends of the slot to be etched.

-57-

Figure 8(d) is a detail enlargement of two of the nozzles shown in figure 8(c). The nozzle radius is $10\ \mu\text{m}$, therefore the nozzle diameter is $20\ \mu\text{m}$. The nozzle barrel is shown as a dotted line. The nozzle barrel does not have a well defined radius, as it is formed by a boron diffusion etch stop for KOH etching. The distance from the edge of the nozzle to the edge of the ink channel is $15\ \mu\text{m}$. This is because the surface of the wafer is typically not perfectly aligned to the (110) crystallographic plane, but may vary by as much as $\pm 1^\circ$. A 1° tilt of the {111} crystallographic planes will result in the bottom of the ink channels being displaced $630\ \mu\text{m} * \tan 1^\circ = 11\ \mu\text{m}$ from the backface mask location.

The line from A to B in figure 8(d) is the line through which the cross section diagrams of figure 9 are taken. This line includes a heater connection on the "A" side, and goes through a 'normal' section of the heater on the "B" side.

Alignment to crystallographic planes

The manufacturing process described herein uses the crystallographic planes inherent in the single crystal silicon wafer to control etching. The orientation of the masking procedures to the {111} planes must be precisely controlled. The orientation of the primary flats on a silicon wafer are normally only accurate to within $\pm 1^\circ$ of the appropriate crystal plane. It is essential that this angular tolerance be taken into account in the design of the mask and manufacturing processes. For example, if a groove is to be etched along the long edges of a 215 mm print head, then a 1° error in the alignment of the wafer to the {111} planes controlling the etch rates will result in a $3,752\ \mu\text{m}$ error in the width of the groove, given sufficient etch time. An alignment error of $\pm 0.1^\circ$ or less is required. This can be achieved by etching a test groove in an area of the wafer which is unused. The groove should be long, and aligned to a (111) plane using the primary flat to align the wafer. The test groove is then over-etched using a solution of 500 grams of KOH per liter of water at 50°C to expose the {111} planes. This solution etches silicon approximately 400 times faster in $\langle 100 \rangle$ directions than $\langle 111 \rangle$ directions. Subsequent angular alignment can be made optically to this groove. Alternatively,

-58-

the wafer can be etched clean through at the groove, which may extend to the edges of the wafer. This will produce another flat on the wafer, aligned with high accuracy to the chosen (111) plane. This flat can then be used for mechanical angular alignment.

5 The surface orientation of the wafer is also only accurate to $\pm 1^\circ$. However, since the wafer thickness is only approximately 650 μm , a $\pm 1^\circ$ error in alignment of the surface contributes a maximum of 11.3 μm of positional inaccuracy when etching through the entire wafer thickness. This is accommodated in the design of the etch masks.

10 Manufacturing process summary

A summary of the preferred manufacturing method is shown in Figure 9(a) to Figure 9(k). This consists of the following major steps:

1) The first manufacturing step is the delivery of the wafers. Silicon wafers are highly recommended over other materials such as gallium
15 arsenide, due to the availability of large, high quality wafers at low cost, the strength of silicon as a substrate, and the general maturity of fabrication processes and equipment.

The example manufacturing process described herein uses n-type wafers with (110) crystallographic orientation. The wafers should not be
20 mechanically or laser gettered, as this will affect back surface etching processes. 150 mm (6") wafers manufactured to standard Semiconductor Equipment and Materials Institute (SEMI) specifications allow 25 mm total thickness variation. The process described herein accommodates this thickness variation during the etching
25 process, so standard tolerance wafers can be used. At the time of writing, 200 mm (8") wafers are in use, and international standards are being set for 300 mm (12") silicon wafers. 300 mm wafers are especially useful for manufacturing heads, as pagewidth A4 (also US letter) print heads can be fabricated as a single chip on these wafers.

-59-

Figure 9(a) shows a (110) n-type 300 mm wafer. The wafer shows 22 A4 print heads of 210 mm print length. Each print head chip is 215 mm long x 8 mm wide. These print heads can be used for US letter or A4 size printing, or as components in multi-chip print heads for A3 printing, sheet fed or web fed digital printing presses, and cloth printing. The boundary of each chip is etched with a deep groove. This groove can be etched before or after the fabrication of the active devices, depending upon process flow for the active devices. However, it is recommended that the grooves be etched after most fabrication steps are complete to avoid problems with resist edge beading at the grooves.

Figure 9(b) shows a cross section of the boundary groove along the short edges of the chip. Crystallographic planes of the {111} family control the etch direction, resulting in a slope of 26.56° in the groove.

Figure 9(c) shows a cross section of the boundary groove along the long edges of the chip. Crystallographic planes of the {111} family control the etch direction, resulting in vertical sidewalls in the groove.

The grooves are only required for proximity print heads, and are formed so that the electrical connections to the print head do not protrude beyond the surface of the chip. The etching of these grooves is best performed after the fabrication of the active devices on the chip, and is described in steps 5) and 6) below.

2) A boron etch stop is then diffused into the silicon. The etch stop is required only in the regions of the bottoms of the ink channels, and is masked from the nozzles by an oversize mask. Boron is diffused to a concentration of 10^{20} atoms per cubic centimeter, to a depth of 15 μm to 20 μm . Figure 9(d) shows a cross section of wafer in the region of a nozzle tip after the boron doping stage.

3) The active devices are then fabricated using a prior art integrated circuit fabrication process with double layer metal. The prior art process may be nMOS, pMOS, CMOS, Bipolar, or other process. In general, the active circuits can be fabricated using unmodified processes. However, some processes

-60-

will need modification to allow for the large currents which may flow through a head. As a large head may have in excess of 28 Amperes flowing through the heater circuits when fully energized, it is essential to prevent electromigration.

Molybdenum can be used instead of aluminum for first level metal, as it is resistant
5 to electromigration. However, as molybdenum requires sputtering, care must be taken not to damage underlying MOS or CMOS structures. The preferred method of preventing electromigration is the provision of very wide aluminum traces which form a grid over the surface of the print head. This approach does not require modification of the manufacturing process, but must be considered in the mask
10 pattern design. The prior-art manufacturing process proceeds unaltered up to the stage of application of the inter-level dielectric.

4) Apply the inter-level dielectric. This can be 3 μm of CVD SiO_2 .

5) Mask and etch the SiO_2 at the borders of the chips. A region
15 of approximately 200 μm inside the edge of the chips is etched. This is the bonding pad region. V grooves are etched in the bonding region. When the wafer is diced, these grooves are sawn lengthways, resulting in a chip with beveled edges. The bonding pads are formed on these bevels, allowing the chip to be bonded without bonding wires or TAB bonding extending above the chip front surface. This is
20 important for close proximity printing, as the print head must be in close proximity (approximately 20 μm) to the recording medium or transfer roller. Conventional bonding methods would interfere with this proximity.

6) Etch the bonding pad grooves. The etch can be performed by
an anisotropic wet etch, which etches the [100] crystallographic direction
25 preferentially to the [111] direction. A solution of 440 grams of potassium hydroxide (KOH) per liter of water can be used for a very high preferential etch rate (approximately 400:1).

Figure 9(b) shows a cross section of V groove at the short edge of the heads after this etching step.

-61-

Figure 9(c) shows a cross section of the boundary groove along the long edges of the chip. Crystallographic planes of the {111} family control the etch direction, resulting in vertical sidewalls in the groove.

A 0.5 μm layer of CVD SiO_2 should be applied after etching the V grooves to insulate the bonding pads from the substrate.

7) Etch the inter-metal vias. In some cases, this step may be able to be combined with the etching of the SiO_2 to form the mask for V groove etching. As the inter-metal SiO_2 is much thicker than normal, tapering of the via sidewalls is recommended.

8) Application of second level metal. As with the first level metal, electromigration must be taken into account. Electromigration can be minimized by using large line-widths for all high current traces, and by using an aluminum alloy containing 2% copper. Molybdenum is not recommended due to the difficulty in bonding to molybdenum thin films. The step coverage of the second level metal is important, as the inter-level oxide is thicker than normal. Also, the vertical sidewalls of the V^- and V^+ grooves along the long edges of the chips must be coated. Adequate step coverage is possible by using low pressure evaporation. Via step coverage can be improved by placing vias only to areas where the first level metal covers field oxide. The preferred process is the deposition by low pressure evaporation of 1mm of 98% aluminum, 2% copper.

9) Mask and etch second level metal. Special attention to masking and etching of the bonding pads is required if the print head is to be used for close proximity printing, as they are fabricated in the V grooves. This introduces two problems: the resist thickness will be greater in the bottom of the V grooves, and the mask will be out of focus. This does not pose a problem for the long edges of the chip, as these are dedicated to the V^+ and V^- power rails, and are not patterned. Bonding pads fabricated on the short edges of the chip should be separated by at least 100 μm . No active circuitry or fine geometry lines should be located in the V grooves. Figure 9(e) shows a cross section of the wafer in the region of a nozzle after this step.

-62-

- 10) Form the heater. The heater material (for example $0.05\ \mu\text{m}$ of TaAl alloy, or refractory materials such as HfB_2 or ZrB_2) can be applied by low pressure evaporation or sputtering. As the heater is planar, masking and etching is straightforward. The heater is masked as a disk rather than an annulus. The centre of the disk is later etched during the nozzle formation step. This is to ensure excellent alignment between the heater and the nozzle. Heater radius should be controlled to finer tolerance than is generally available in a $1.5\ \mu\text{m}$ process, and the use of a stepper for $0.5\ \mu\text{m}$ process is recommended. Figure 9(f) shows a cross section of the wafer in the region of a nozzle after this step.
- 11) Apply a protective coating of Si_3N_4 . This is applied to the front face of the wafer only, and should be at least $0.1\ \mu\text{m}$ thick to protect the front face of the wafer from attack by the long wet-etch of the back face of the wafer. Figure 9(g) shows a cross section of the wafer in the region of a nozzle after this step.
- 12) Mask the back surface of the wafer. Si_3N_4 is used as a mask, as resist is attacked by the wet etching solution, and the etch rate of SiO_2 is too high (approx. $20\ \text{\AA}/\text{minute}$) for effective use as a mask. The etch rate of Si_3N_4 is approximately $14\ \text{\AA}/\text{hour}$. Apply a $0.5\ \mu\text{m}$ layer of Si_3N_4 , to the back surface of the wafer, followed by spin coating with $0.5\ \mu\text{m}$ of resist. Expose and develop the resist on the back surface of the wafer using a mask of the ink channels. Alignment is taken from the front surface of the wafer by modified alignment optics of the lithography equipment. Alignment of this step is not critical, and can be performed to an accuracy of approximately $\pm 4\ \mu\text{m}$. The Si_3N_4 is then etched and the resist is stripped.
- 13) Etch the ink channels. This is performed by a wet etch of the silicon using a solution of potassium hydroxide in water. The advantage of a wet etch over an anisotropic plasma etch is very low equipment cost, combined with highly accurate etch angles determined by crystallographic planes. The etchant exposes the $\{111\}$ planes. Four of these planes are oriented at an angle of 90° to the wafer surface. The ink channels are oriented parallel to two of these parallel

-63-

planes so that the {111} planes define the vertical sidewalls of the ink channels. A further two {111} planes are oriented at an angle of 26.56° to the wafer surface in the plane of the ink channels, and limit the etch depth of the ink channels. For this reason, the ink channel mask must be made longer than the required channel length, so that the full etch depth is attained where required in the ink channel. Etch the wafer in a 50% solution of KOH in water at 80°C . The etch rate is approximately $0.8\ \mu\text{m}/\text{minute}$, and an etch depth of $620\ \mu\text{m}$ is required, so the etch duration should be around 12.9 hours. The exact time is not critical, due to the boron etch stop. The etch at this stage is a bulk silicon etch which should stop shortly before the boron etch stop is reached. The main purpose of this etching step is to reduce the silicon thickness in the ink channels, so that the etch step which defines the nozzle barrels using the boron etch stop is much shorter, and does not significantly etch the SiO_2 at the nozzle tip. Figure 9(h) is a perspective view of some of the ink channels after etching. This view is from the back surface of the wafer. Figure 9(i) shows a cross section of the wafer in the region of a nozzle after this step. The ink channel etched into the silicon from the rear of the wafer appears asymmetrical because the line A to B is not straight: at the A side the cross section is perpendicular to the ink channel, and at the B side the cross section runs along the ink channel. The Si_3N_4 masking layer should not be stripped.

14) Mask the nozzle tip using resist. This must be performed accurately, as the alignment of the nozzle tip to the heater, and the radius of the nozzle tip, both affect drop ejection performance. These parameters should be controlled to an accuracy of better than $0.5\ \mu\text{m}$, and preferably better than $0.3\ \mu\text{m}$. Figure 9(j) shows a cross section of the wafer in the region of a nozzle after this step.

15) Etch the nozzle tip. The first step is the etching of the Si_3N_4 layer. The second step is etching the heater. As the heater is very thin, a wet etch can be used. The third step is the etching of the SiO_2 forming the nozzle tip. This should be etched with an anisotropic etch, for example an RIE etch using $\text{CF}_4 - \text{H}_2$ gas mixture. The etch is down to silicon in the nozzle region. The resist is then

-64-

stripped. Figure 9(k) shows a cross section of the wafer in the region of a nozzle after this step.

16) Etch the nozzle barrels. This is also performed by a wet etch of the silicon using KOH. Etching proceeds from both sides of the wafer at the same time, with etching from the rear occurring through the ink channels, and etching from the front occurring through the nozzle tip. Approximately 20 μm of silicon thickness must be etched, 10 μm from each side. However, as the boron etch stop controls the geometry of the final nozzle barrel, etch time is not critical, and should be substantially longer than the minimum etch time to accommodate 25 μm variations in wafer thickness and variable etch rates. Etch the wafer in a 50% solution of KOH in water at 80°C for 1 hour. Figure 9(l) is a perspective view of some of the nozzle barrels in two of the ink channels after this step. This view is from the back surface of the wafer, looking down into two adjacent ink channels. The circular apertures are the nozzle tips. The arrangement is for a 800 dpi printer with 31.75 μm pixel spacing. The nozzles in each channel are spaced at 63.5 μm , and are offset between the two channels by 31.75 μm . The diameter of the nozzle tip is 20 μm . The line A to B is the line of the cross sections in figure 9., as shown in figure 8(d). Figure 9(m) shows a cross section of the wafer in the region of a nozzle after this step.

17) Form the passivation layer. As the monolithic head is in contact with heated water based ink during operation, effective passivation is essential. A 0.5 μm conformal layer of Si_3N_4 applied by PECVD can be used. Use SiH_4 at 200 sccm and NH_3 at 2000 sccm, pressure of 1.6 torr, temperature of 250°C, at 46 watts for 50 minutes. Figure 9(n) shows a cross section of the wafer in the region of a nozzle after this step.

18) A hydrophobic surface coating may be applied at this stage, if the coating chosen can survive the subsequent processing steps. Otherwise, the hydrophobic coating should be applied after TAB bonding. There are many hydrophobic coatings which may be used, and many methods which may be used to apply them. By way of illustration, one such suitable coating is fluorinated diamond-

-65-

like carbon (F^{*}DLC), an amorphous carbon film with the outer surface substantially saturated with fluorine. A method of applying such a film using plasma enhanced chemical vapor deposition (PECVD) equipment is described in US patent number 5,073,785. It is not essential to apply a separate hydrophobic layer. Instead, the exposed dielectric layer can be treated with a hydrophobising agent. For example, if SiO₂ is used as the passivation layer in place of Si₃N₄, the device can be treated with dimethyldichlorosilane to make the exposed SiO₂ hydrophobic. This will affect the entire nozzle, unless the regions which are to remain hydrophilic are masked, as dimethyldichlorosilane fumes will affect any exposed SiO₂.

10 The application of a hydrophobic layer is required if the ink is water based, or based on some other polar solvent. If the ink is wax based or uses a non-polar solvent, then the front surface of the head should be lipophobic. In summary, the front surface of the head should be fabricated or treated in such a manner as to repel the ink used. When using the physical device configuration disclosed herein, the hydrophobic layer need not be limited to the front surface of the device. The entire device may be coated with a hydrophobic layer (or lipophobic layer is non-polar ink is used) without significantly affecting the performance of the device. If the entire device is treated with an ink repellent layer, then the nozzle radius should be taken as the inside radius of the nozzle tip, instead of the outside radius.

20 19) Bond, package and test. The bonding, packaging, and testing processes can use standard manufacturing techniques. Bonding pads must be opened out from the Si₃N₄ passivation layer. Although the bonding pads are fabricated at an angle in the V groove, no special care is required to mask them, as the entire V groove area can be stripped of Si₃N₄. After the bonding pads have been opened, the resist must be stripped, and the wafer cleaned. Then wafer testing can proceed. Then the wafer is diced. The wafers should be sawed instead of scribed and snapped, to prevent breakage of long heads, and because the wafer is weakened along the nozzle rows. The diced wafers (chips) are then mounted in the ink channels. For color heads, the separate ink channels are sealed to the chip at this stage. After mounting, the chip is bonded, and dry device tests performed. The

25

30

-66-

device is then be connected to the ink supply, ink pressure is applied, and functional testing can be performed. Figure 9(0) shows a cross section of the wafer in the region of a nozzle after this step.

In Figure 9(a) to Figure 9(o), 100 is ink, 101 is silicon, 102 is CVD SiO₂, 103 is the heater material, 105 is boron doped silicon, 106 is the second layer metal interconnect (aluminum), 107 is resist, 108 is silicon nitride (Si₃N₄) and 109 is the hydrophobic surface coating.

Alternative fabrication processes

Many other manufacturing processes are possible. The above manufacturing process is not the simplest process that can be employed, and is not the lowest cost practical process. However, the above process has the advantage of fabrication of high performance data distribution devices and drive transistors on the same wafer as the nozzles. The process is also readily scalable, and 1mm line widths can be used if desired.

The use of 1μm line widths (or even finer geometries) allows more circuitry to be integrated on the wafer, and allows a reduction in either the size or the on resistance (or both) of the drive transistors. The smaller device geometries can be used in the following, or a combination of the following, ways:

- 1) To reduce the width of the monolithic head
- 2) To increase the yield of the head, by incorporating more sophisticated fault tolerance circuitry
- 3) To increase the number of nozzles on the head without increasing chip area.
- 4) To increase the resolution of the print head by more closely spacing the nozzles in terms of the linear dimensions.
- 5) To incorporate more of the total system circuitry on the chip. For example, data phasing circuits can be incorporated on chip, and the head can be supplied with a standard memory interface, via which it acquires the printing data by direct memory access.

-67-

It is possible to alter the nozzle formation processes in many ways. For example, it is possible to create the heater using a self-aligned vertical technique instead of the planar heater formation described herein.

The process described herein is a preferred process for production of printing heads as it allows high resolution, full color heads to incorporate drive
5 circuitry, data distribution circuitry, and fault tolerance, and can be manufactured with relatively low cost extensions to standard CMOS production processes. Many simpler head manufacturing processes can be derived. In particular, heads which do not include active circuitry may be manufactured using much simpler processes.

10 Power supply connections

Large print heads with many thousands of nozzles may have current consumption in excess of 20 Amperes. This would cause significant problems if standard interconnection techniques were used. The present invention is a method of achieving very high current delivery to print heads by utilizing the entire long
15 edges of the print head as power terminals.

The V^+ and V^- connections are fabricated as 200 μm wide strips of 1 μm aluminum along the edges of the chip which are perpendicular to the print direction. Lines of aluminum extend from the V^+ connection until the row of nozzles closest to the V^- connection. These lines pass between every second nozzle,
20 and are as wide as the device layout and process technology will allow. Lines of aluminum extend from the V^- connection until the row of nozzles closest to the V^+ connection. These lines are interdigitated with the V^+ lines.

This power supply configuration allows tens of amperes to be supplied to print heads with very low electrical resistance and without significant
25 temperature rise in the on-chip connections.

Also, electromigration is sufficiently low that it is not a significant factor in device reliability.

For example, the table "LIFT type A4-6-800" Appendix A lists some of the characteristics on one configuration of a pagewidth full color A4 print head.

-68-

This print head is capable of printing 6 color A4 pages (using CC'MM'YK or other color models) at 800 dpi in approximately 1.3 seconds. The print head has 39,744 active nozzles. There are also 39,744 redundant nozzles incorporated for fault tolerance. A maximum of 4,968 nozzle heaters are activated at any one time. If the average current to each of the active nozzles is 6.0 mA, then the head must be supplied with an average of 29.8 Amperes while printing full black. This level of current supply is well beyond the normal current supply to integrated circuits, so standard wire-bonded or TAB connections are not appropriate.

Normally, power dissipation would also be a problem. However, this print-head can operate in a self-cooling manner, where essentially all of the waste heat is dissipated as a temperature rise in the ink. The use of an ink carrier with a high specific heat capacity, such as water, is recommended for self-cooling operation. The print head is effectively 'water-cooled' without requiring any special 'plumbing' or ink recycling. The flow of coolant (the ink) is also adjusted to the variable power dissipation, as almost all power is dissipated in the process of ink drop ejection. This maintains the print head temperature within a small range.

The present invention provides a solution to the problem of high current power connections. Elongated bonding pads are formed along substantially the entire length of opposite edges of the chip. The V^+ connection is formed on one edge, and the V^- connection is formed on the opposite edge. The recommended edges to use are the edges perpendicular to the print direction. This choice of edges has the following benefits:

- 1) the length of the edges, and thus the power connections is proportional to the number of nozzles, and therefore to the power supply current;
- 2) the current flow is evenly distributed along these edges;
- 3) for print heads with large numbers of nozzles, the edges which are perpendicular to the print direction are the longest edges, and will therefore support the most current; and
- 4) for close proximity print heads, the distance between the print head and the print medium is very small. Placement of the power supply rails on the edges perpendicular to the print direction simplifies construction of the print head

-69-

assembly by allowing the data connections to be situated on the other edges, which in some configurations can be past the edges of the print medium.

Figure 10 shows one possible basic layout for a 6 color 800 dpi A4 pagewidth print head. The print head is 215 mm long by 8 mm wide, and is fabricated from a single crystal silicon wafer cut longitudinally from the boule. The crystallographic orientation of the surface is (110). The ink channels and nozzles are anisotropically etched using wet etchants which etch $\langle 111 \rangle$ directions at a much slower rate than $\langle 100 \rangle$ or $\langle 110 \rangle$ directions. The V^+ and V^- connections are fabricated as 200 μm wide strips of 1 μm aluminum along the edges of the chip which are perpendicular to the print direction. Lines of aluminum (not shown) extend from the V^+ connection until the row of nozzles closest to the V^- connection. These lines pass between every second nozzle, and are as wide as the device layout and process technology will allow. With the parameters as shown here, the V^+ lines can be 30 μm wide. Lines of aluminum (also not shown) extend from the V^- connection until the row of nozzles closest to the V^+ connection. These lines are interdigitated with the V^+ lines.

It is also possible to form the bonding pads for V^+ and V^- along a length less than the entire long edges of the chip, or to intersperse the V^+ and V^- connections along both of the edges.

The current density through 1 μm aluminum metallization running the entire length of a 215 mm print head carrying 29.8 Amperes is $1.4 \times 10^4 \text{ A/cm}^2$. This is well below the maximum current density allowable for power supply connections in standard integrated circuits.

Electromigration

One problem which can occur with high currents in aluminum metallization is electromigration. The median time to failure (MTF) due to electromigration of aluminum leads evaporated onto a cold substrate has been experimentally found to be approximated by:

$$MTF = \frac{4.1 \times 10^{16} AB}{j^2} e^{-\frac{0.48}{kT}} \quad -70-$$

Where:

MTF is in hours;

A is the cross section of the lead in cm²;

5 *B* is a units conversion constant equal to 1 A² hour cm⁻⁶;

j is the current density in A cm⁻²; and

k is Boltzmann's constant = 8.62 x 10⁻⁵ eV/K.

Reference: James R. Black, "Electromigration Failure Modes in
Aluminum Metallization for Semiconductor Devices," *Proc. IEEE* 57 pp. 1587-
10 1594, 1969

Figure 11(a) shows a possible nozzle placement for a small section
of one color of an 800 dpi print head. There are four rows of nozzles shown, spaced
at 6 pixel widths (190.5 μm). Two of the rows are for main nozzles, and two of the
rows are for redundant nozzles. The nozzles in each row are spaced at two pixel
15 widths (63.5 μm), and offset from the adjacent row by one pixel width (31.75 μm).

Figure 11(b) is a detail enlargement of a small section of figure
11(a), showing three nozzles in one row. The diagram shows the nozzle 200, drive
transistor 201, and inverting buffer 216. Figure 11(b) shows wide vertical aluminum
leads carrying the V⁺ and V⁻ power supplies. Also shown are wide horizontal
20 connections that join the V⁺ and V⁻ lines between each row of nozzles, ensuring that
the current flow for differing patterns of activated heaters is evenly distributed. The
arrangement shown is only one of many possible arrangements, and other
arrangements can be readily derived without departing from the scope of the
invention.

25 Highest electromigration occurs where the power supply
connections are the thinnest. This occurs between the nozzles of a row. A width of
at least 30 μm is available for the V⁺ line between each alternate nozzle when using
the layout shown in figure 11(b). The alternate spaces between nozzles can
accommodate a V⁻ line of approximately 30 μm. Each V⁺ or V⁻ line carries 1/1653

-71-

of the total current, being a maximum of 18 mA. The current is well distributed over the various V^+ and V^- lines due to the matrix connections running along the chip.

Evaluating for:

5 $A = 30 \mu\text{m} \times 1 \mu\text{m} = 3 \times 10^{-7} \text{ cm}^2;$

$j = 6 \times 10^4 \text{ A cm}^{-2};$

$T = 50^\circ\text{C} = 323^\circ\text{K}$

Then

$MTF = 1.05 \times 10^8 \text{ hours (approximately 12,000 years)}$

10 This MTF is sufficiently large to indicate that electromigration is not a significant problem for print heads using the present invention.

Electromigration can be further reduced by alloying a small amount (1% to 2%) of copper in the aluminum, and/or heating the substrate during evaporation to promote larger aluminum grain sizes.

15 Connection to the power supply

Connection of the V^+ and V^- connections to the power supply can be achieved in many ways, including, but not limited to:

multiple spring contacts along the length of the V^+ and V^- pads, which can be formed from a single piece of slotted metal;

20 connection to two rigid metal pieces along the length of the V^+ and V^- pads, using a conductive paste to ensure low ohmic connections;

multiple wire bonds distributed along the length of the V^+ and V^- pads;

25 TAB bonding, involving the application of solder bumps along the length of the V^+ and V^- pads and application of TAB film to the solder bumps. To allow standard solder bump formation, the region of the V^+ and V^- pads used for connections can be divided into $100 \mu\text{m}$ 'pads' which are all electrically connected.

Proximity print heads require the recording medium to be in close proximity to the nozzle tip. A preferred method of manufacturing proximity heads

-72-

involves etching the nozzles through a substrate of single crystal silicon. When the heads are manufactured in this way, the drive transistors and data distribution circuits can be fabricated on the same wafer as the nozzles and nozzle heaters.

While this manufacturing method has many advantages, a problem exists in making external connections to the head. Using standard wire bonding techniques, the wires will protrude past the plane of the recording material. For single chip pagewidth heads this need not be a problem, as the electrical connections can be beyond the edges of the recording medium. However, for print heads which are not wider than the recording medium, and for multi-chip print heads, this is a significant problem.

Another feature of the present invention is a print head bonding technique which solves the above problem. The bonding pads are formed on the surface of the print head substrate in a region which is recessed or (preferably) chamfered. The bonding pads are formed using well known planar deposition and etching techniques. Care must be taken with the patterning of the bonding pads, as optical projection systems used in semiconductor patterning have a very small depth of field. Although the projected image will not be in focus, adequate patterning can be achieved by ensuring that there are no small features or linewidths present in the chamfered or recessed areas, and by ensuring that there is adequate separation between the bonding pads.

Electrical connection can then be achieved by any technique which does not protrude past the surface of the substrate by a distance equal to or greater than the distance between print head and recording medium.

Recessing or chamfering of the substrate in the region of the bonding pads can be achieved by various means, but is preferably achieved by chemical etching. Recesses can be etched isotropically or anisotropically, and chamfering is preferably achieved by anisotropic etching.

Electrical connections for Proximity printing

Figure 10 shows one possible basic layout for a 6 color 800 dpi A4 pagewidth print head in accordance with the invention. The print head is 105 mm long by 8 mm wide, and is fabricated from a 150mm single crystal silicon wafer.

-73-

The crystallographic orientation of the surface is (110). The ink channels and nozzles are anisotropically etched using wet etchants which etch $\langle 111 \rangle$ directions at a much slower rate than $\langle 100 \rangle$ or $\langle 110 \rangle$ directions. The V^+ and V^- connections are fabricated as $200\ \mu\text{m}$ wide strips of $1\ \mu\text{m}$ aluminum along the edges of the chip which are perpendicular to the print direction. The bonding pads 687 are formed as $200\ \mu\text{m} \times 100\ \mu\text{m}$ rectangles of aluminum $1\ \mu\text{m}$ thick along the edges of the chip which are parallel to the print direction.

Figure 12(a) illustrates the problem which occurs for proximity print heads where the surface upon which external connections are to be made is the same surface which must be in close proximity to the recording medium. The surface of the silicon substrate 101 is approximately $20\ \mu\text{m}$ from the recording medium 51. However, the wire bond 688 protrudes from the surface of the silicon substrate 101 by several hundred μm , and interferes with the recording medium 51.

Figure 12(b) shows a construction which solves this problem. The silicon substrate 101 is chamfered in the region of the bonding pads as shown in figure 9(b). This chamfering is achieved by anisotropic etching which etches the $\langle 111 \rangle$ crystallographic directions more slowly than $\langle 100 \rangle$ or $\langle 110 \rangle$ crystallographic directions. The bonding connection 689 is achieved by a means, which may be Tape Automated Bonding (TAB) or other means, which does not protrude from the silicon substrate in the region of the chamfer sufficiently to interfere with the recording medium 51.

The foregoing describes a number of preferred embodiments of the present invention. Modifications, obvious to those skilled in the art, can be made thereto without departing from the scope of the invention.

Appendix A

LIFT head type A4-6-800	
<p>This is a six color print head for A4 size printing. The print head is fixed, and is the full width of the A4 paper. Resolution is 800 dpi bi-level for high quality color output.</p>	
Basic specifications	Derivation
Resolution 800 dpi	<i>Specification</i>
Print head length 215 mm	<i>Width of print area, plus 5 mm</i>
Print head width 8 mm	<i>Derived from physical and layout constraints of head</i>
Ink colors 6	<i>CC'MM'YK</i>
Page size A4	<i>Specification</i>
Print area width 210 mm	<i>Pixels per line / Resolution</i>
Print area length 297 mm	<i>Total length of active printing</i>
Page printing time 1.3 seconds	<i>Derived from scans, lines per page and dot printing rate</i>
Pages per minute 37 ppm	<i>60 / (120% of print time in seconds)</i>
Basic IC process 1.5 µm CMOS	<i>Recommendation</i>
Bitmap memory requirement 44.3 MBytes	<i>Bitmap memory required for one scan (cannot pause)</i>
Pixel spacing 31.8 µm	<i>Reciprocal of resolution</i>
Pixels per line 6,624	<i>Active nozzles / Number of colors</i>
Lines per page 9,354	<i>Scan distance * resolution</i>
Pixels per page 61,960,896	<i>Pixels per line * lines per page</i>
Drops per page 247,843,584	<i>Pixels per page * simultaneous ink colors</i>
Average data rate 32.9 MBytes/sec	<i>Pixels per second * ink colors / 8 MBits</i>
Ejection energy per drop 977 nJ	<i>Energy applied to heater in finite element simulations</i>
Energy to print full black page 242 J	<i>Drop ejection energy * drops per page</i>
Recording medium speed 22.0 cm/sec	<i>1 / (resolution * actuation period times phases)</i>
Yield and cost	Derivation
Number of chips per head 1	<i>Recommendation</i>
Wafer size 300 mm (12")	<i>Recommendation</i>
Chips per wafer 22	<i>From chip size and recommended wafer size</i>
Print head chip area 17.2 cm ²	<i>Chip width * length</i>
Yield without fault tolerance 0.34%	<i>Using Murphy's method, defect density = 1 per cm²</i>
Yield with fault tolerance 89%	<i>See fault tolerant yield calculations (D=1/cm², CF=2)</i>
Functional print heads per month 195,998	<i>Assuming 10,000 wafer starts per month</i>
Print head assembly cost \$10	<i>Estimate</i>
Factory overhead per print head \$17	<i>Based on \$120m. cost for refurbished 1.5 µm Fab line amortised over 5 years, plus \$16m. P.A. operating cost</i>
Wafer cost per print head \$31	<i>Based on materials cost of \$600 per wafer</i>
Approx. total print head cost \$58	<i>Sum of print head assembly, overhead, and wafer costs</i>

Appendix A (cont'd.)

LIFT head type A4-6-800	
Nozzle and actuation specifications	<i>Derivation</i>
Nozzle radius..... 10 μm	<i>Specification</i>
Number of actuation phases..... 8	<i>Specification</i>
Nozzles per phase..... 4,968	<i>From page width, resolution and colors</i>
Active nozzles per head..... 39,744	<i>Actuation phases * nozzles per phase</i>
Redundant nozzles per head..... 39,744	<i>Same as active nozzles for 100% redundancy</i>
Total nozzles per head..... 79,488	<i>Active plus redundant nozzles</i>
Drop rate per nozzle..... 6,944 Hz	<i>1/(heater active period * number of phases)</i>
Heater radius..... 10.5 μm	<i>From nozzle geometry and radius</i>
Heater thin film resistivity..... 2.3 μΩm	<i>For heater formed from TaAl</i>
Heater resistance..... 1,517 Ω	<i>From heater dimensions and resistivity</i>
Average heater pulse current..... 6.0 mA	<i>From heater power and resistance</i>
Heater active period..... 18 μs	<i>From finite element simulations</i>
Settling time between pulses..... 126 μs	<i>Active period * (actuation phases-1)</i>
Clock pulses per line..... 5,678	<i>Assuming multiple clocks and no transfer register</i>
Clock frequency..... 39.4 MHz	<i>From clock pulses per line, and lines per second</i>
Drive transistor on resistance..... 56 Ω	<i>From recommended device geometry</i>
Average head drive voltage..... 9.4 V	<i>Heater current * (heater +drive transistor resistance)</i>
Drop selection temperature..... 50 °C	<i>Temperature at which critical surface tension is reached</i>
Heater peak temperature..... 120 °C	<i>From finite element simulations</i>
Ink specifications	<i>Derivation</i>
Basic ink carrier..... Water	<i>Specification</i>
Surfactant..... 1-Hexadecanol	<i>Suggested method of achieving temperature threshold</i>
Ink drop volume..... 9 pl	<i>From finite element simulations</i>
Ink density..... 1.030 g/cm ³	<i>Black ink density at 60°C</i>
Ink drop mass..... 9.3 ng	<i>Ink drop volume * ink density</i>
Ink specific heat capacity..... 4.2 J/Kg°C	<i>Ink carrier characteristic</i>
Max. energy for self cooling..... 1,164 nJ/drop	<i>Ink drop heat capacity * temperature increase</i>
Total ink per color per page..... 0.56 ml	<i>Drops per page per color * drop volume</i>
Maximum ink flow rate per color..... 0.41 ml/sec	<i>Ink per color per page / page print time</i>
Full black ink coverage..... 35.7 ml/m ²	<i>Ink drop volume * colors * drops per square metre</i>
Ejection ink surface tension..... 38.5 mN/m	<i>Surface tension required for ejection</i>
Ink pressure..... 7.7 kPa	<i>2 * Ejection ink surface tension / nozzle radius</i>
Ink column height..... 763 mm	<i>Ink column height to achieve ink pressure</i>

Claim:

1. A drop on demand print head comprising a plurality of electrothermal heater elements formed on a silicon chip and electrical power connections for supplying power to said electrothermal elements, the improvement wherein said connections are formed on the chip surface substantially at opposite edges of the print head and extend a distance substantially equal to the length of the corresponding edge.

2. The invention defined in Claim 1 wherein said connections are adapted to conduct current in excess of 20 Amperes.

3. The invention defined in Claim 1 wherein said connections have a width equal to or greater than approximately 200 μ m.

4. The invention defined in Claim 1 wherein said connections have a thickness of approximately 1 μ m.

5. The invention defined in Claim 1 wherein said connections are generally perpendicular to the print feed direction of said print head.

6. The invention defined in Claim 1 further comprising a main connection from the electrical power circuits on said chip surface to an external circuit, said main connection being characterized by the region of contact to said chip electrical power circuits being situated in a recess formed in the substrate of said chip.

7. The invention defined in Claim 6 wherein said recess is formed to a depth which is in excess of 10 μ m, and is less than the thickness of said substrate.

-77-

8. The invention defined in Claim 6 wherein said recess is formed to a depth so that the tops of said main electrical connection do not protrude beyond the surface of said chip electrical power circuits.

9. In a drop on demand print head comprising a plurality of integrated circuits formed on a silicon substrate, an arrangement of an electrical connection from said integrated circuit to an external circuit, said arrangement being characterized by the region of contact to said integrated circuit being situated in a bevel formed in the substrate of said integrated circuit.

10. The invention defined in Claim 9 wherein said bevel is formed to a depth so that the tops of said electrical connections do not protrude beyond the surface of said integrated circuit, said surface being the surface in which said bevel is formed.

11. The invention defined in Claim 1 wherein said print head comprises:

- (a) a plurality of drop-emitter nozzles;
- (b) a body of ink associated with said nozzles;
- (c) pressure means for subjecting ink in said body of ink to a pressure of at least 2% above ambient pressure, at least during drop selection and separation;
- (d) drop selection means for selecting predetermined nozzles and generating a difference in meniscus position between ink in selected and non-selected nozzles; and
- (e) drop separating means for causing ink from selected nozzles to separate as drops from the body of ink, while allowing ink to be retained in non-selected nozzles.

12. The invention defined in Claim 1 wherein said print head comprises:

- (a) a plurality of drop-emitter nozzles;
- (b) a body of ink associated with said nozzles;

-78-

(c) drop selection means for selecting predetermined nozzles and generating a difference in meniscus position between ink in selected and non-selected nozzles; and

(d) drop separating means for causing ink from selected nozzles to separate as drops from the body of ink, while allowing ink to be retained in non-selected nozzles, said drop selecting means being capable of producing said difference in meniscus position in the absence of said drop separation means.

13. The invention defined in Claim 1 wherein said print head comprises:

(a) a plurality of drop-emitter nozzles;

(b) a body of ink associated with said nozzles, said ink exhibiting a surface tension decrease of at least 10 mN/m over a 30°C temperature range;

(c) drop selection means for selecting predetermined nozzles and generating a difference in meniscus position between ink in selected and non-selected nozzles; and

(d) drop separating means for causing ink from selected nozzles to separate as drops from the body of ink, while allowing ink to be retained in non-selected nozzles.

14. The invention defined in Claim 9 wherein said print head comprises:

(a) a plurality of drop-emitter nozzles;

(b) a body of ink associated with said nozzles;

(c) pressure means for subjecting ink in said body of ink to a pressure of at least 2% above ambient pressure, at least during drop selection and separation;

(d) drop selection means for selecting predetermined nozzles and generating a difference in meniscus position between ink in selected and non-selected nozzles; and

-79-

(e) drop separating means for causing ink from selected nozzles to separate as drops from the body of ink, while allowing ink to be retained in non-selected nozzles.

15. The invention defined in Claim 9 wherein said print head comprises:

- (a) a plurality of drop-emitter nozzles;
- (b) a body of ink associated with said nozzles;
- (c) drop selection means for selecting predetermined nozzles and generating a difference in meniscus position between ink in selected and non-selected nozzles; and
- (d) drop separating means for causing ink from selected nozzles to separate as drops from the body of ink, while allowing ink to be retained in non-selected nozzles, said drop selecting means being capable of producing said difference in meniscus position in the absence of said drop separation means.

16. The invention defined in Claim 9 wherein said print head comprises:

- (a) a plurality of drop-emitter nozzles;
- (b) a body of ink associated with said nozzles, said ink exhibiting a surface tension decrease of at least 10 mN/m over a 30°C temperature range;
- (c) drop selection means for selecting predetermined nozzles and generating a difference in meniscus position between ink in selected and non-selected nozzles; and
- (d) drop separating means for causing ink from selected nozzles to separate as drops from the body of ink, while allowing ink to be retained in non-selected nozzles.

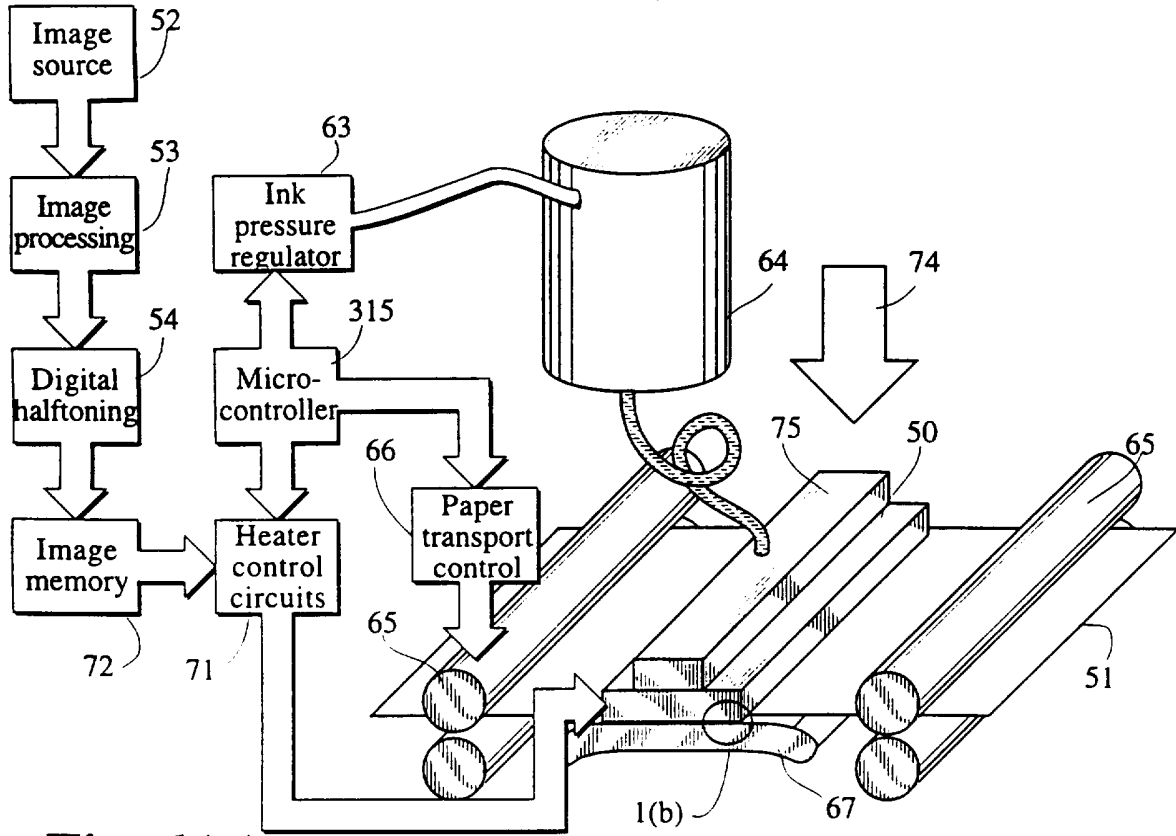

Fig. 1(a)

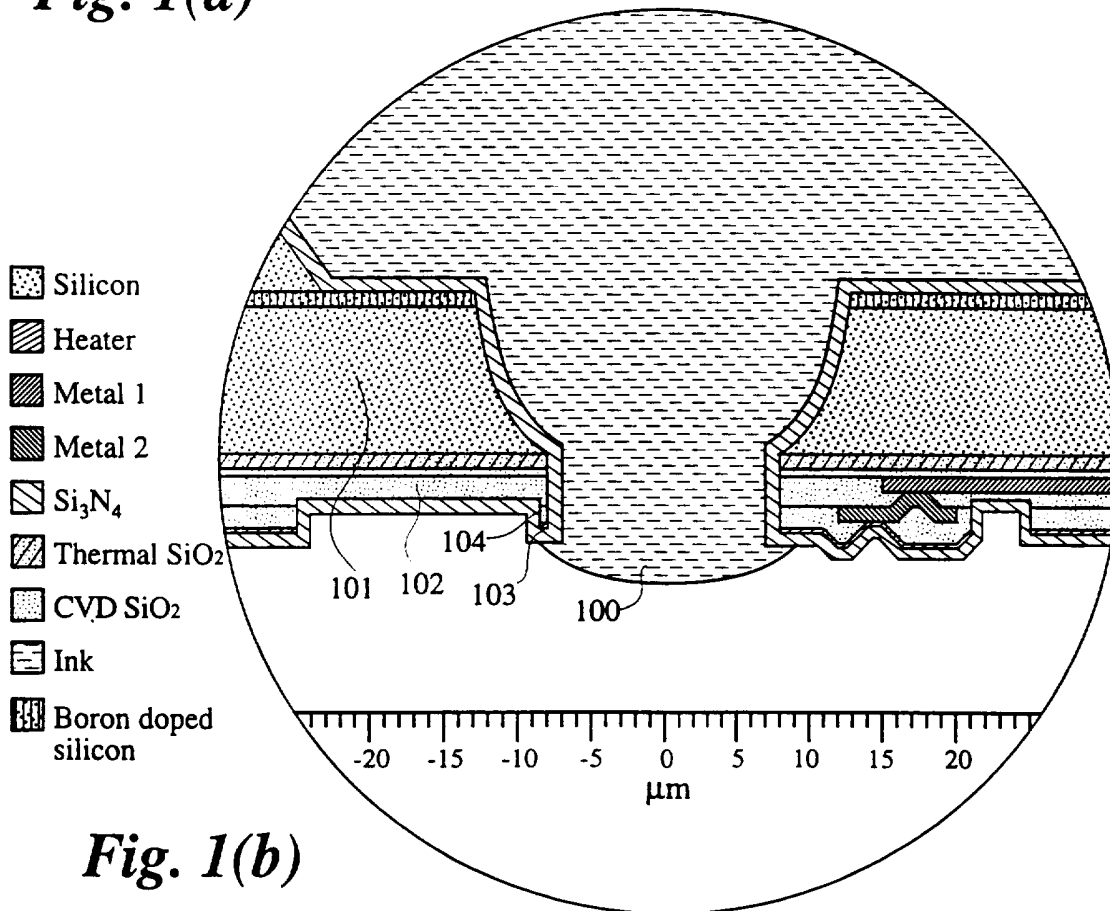

Fig. 1(b)

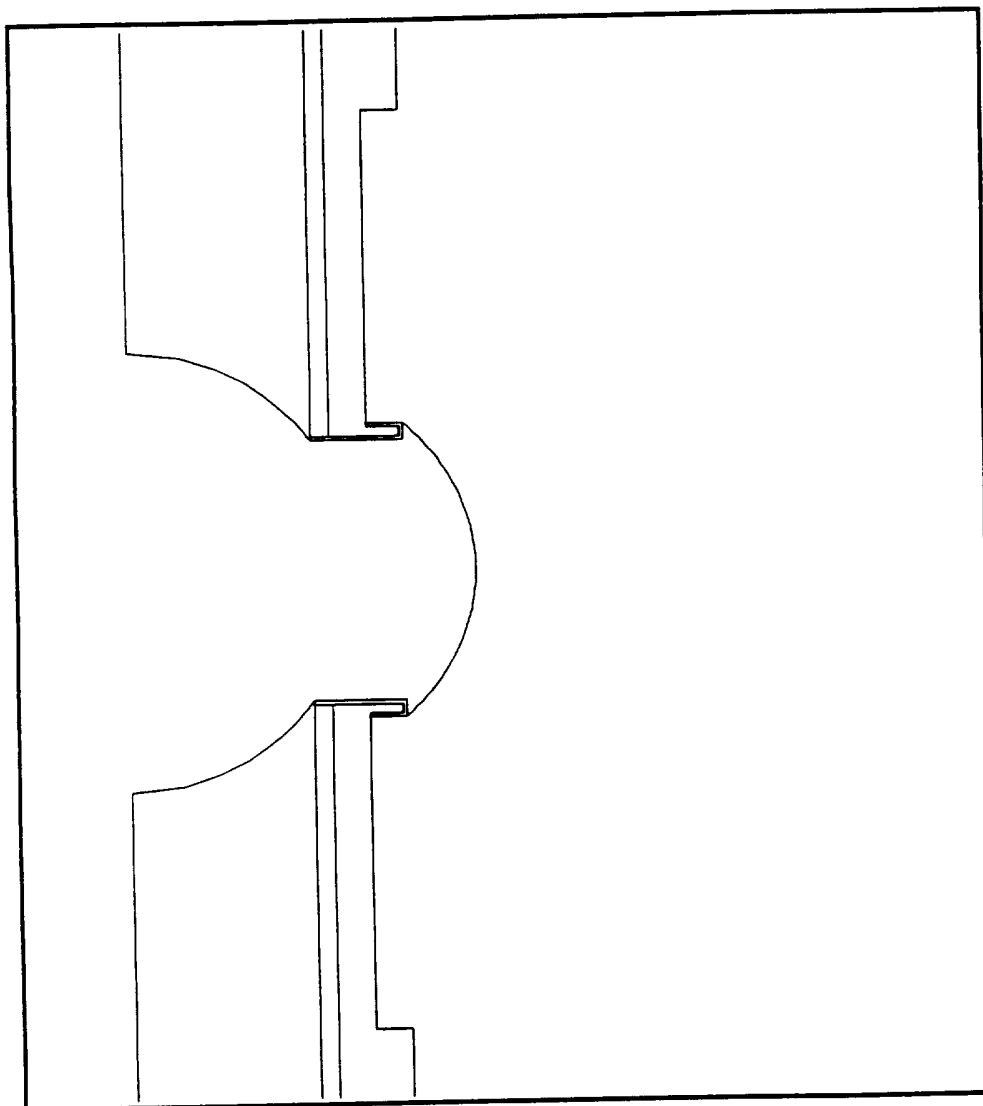

Fig. 2(a)

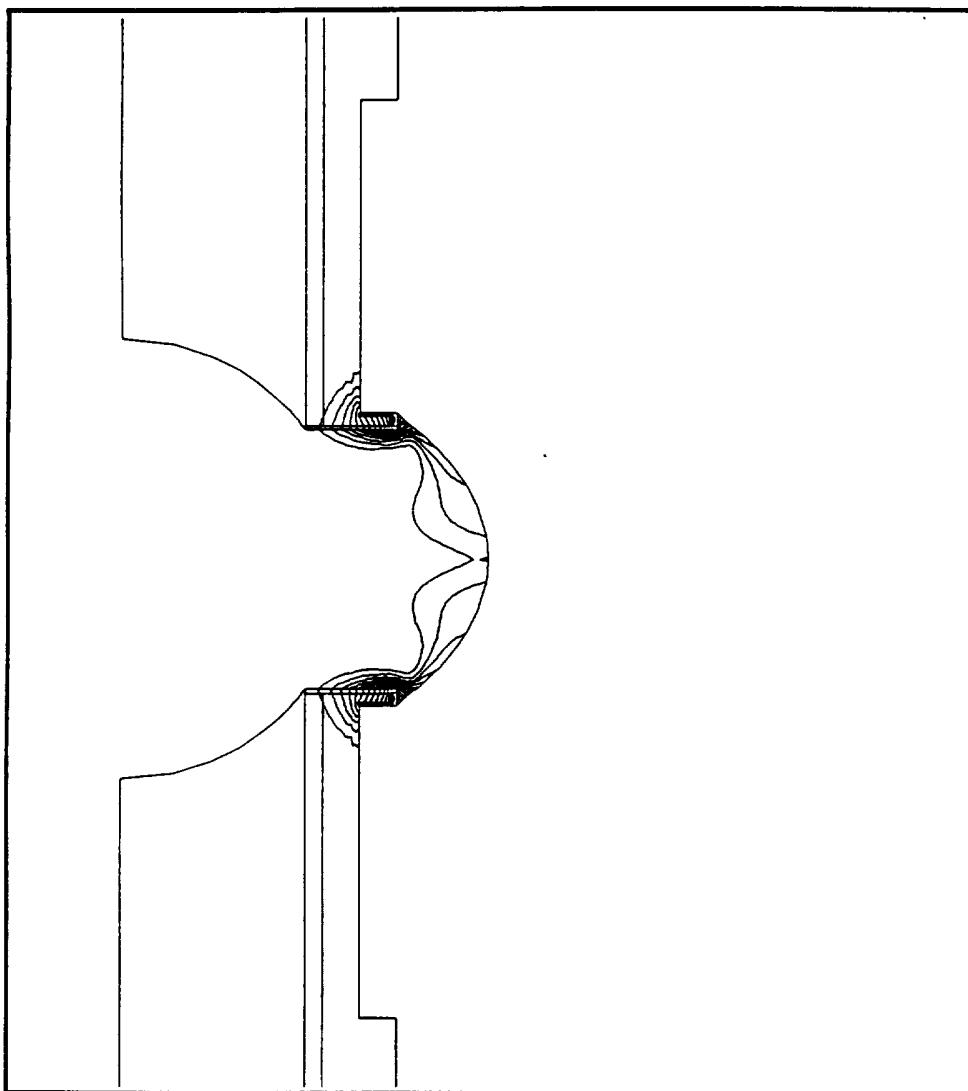

Fig. 2(b)

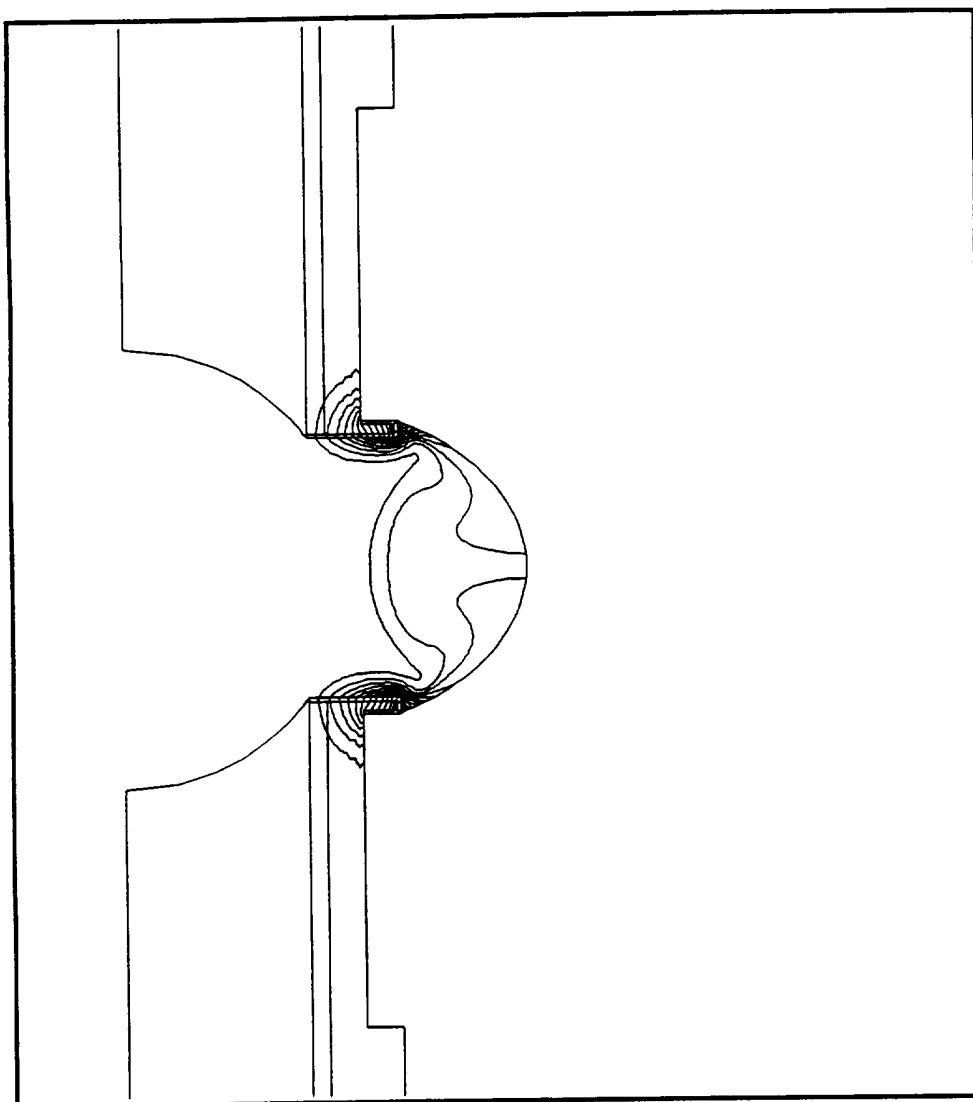

Fig. 2(c)

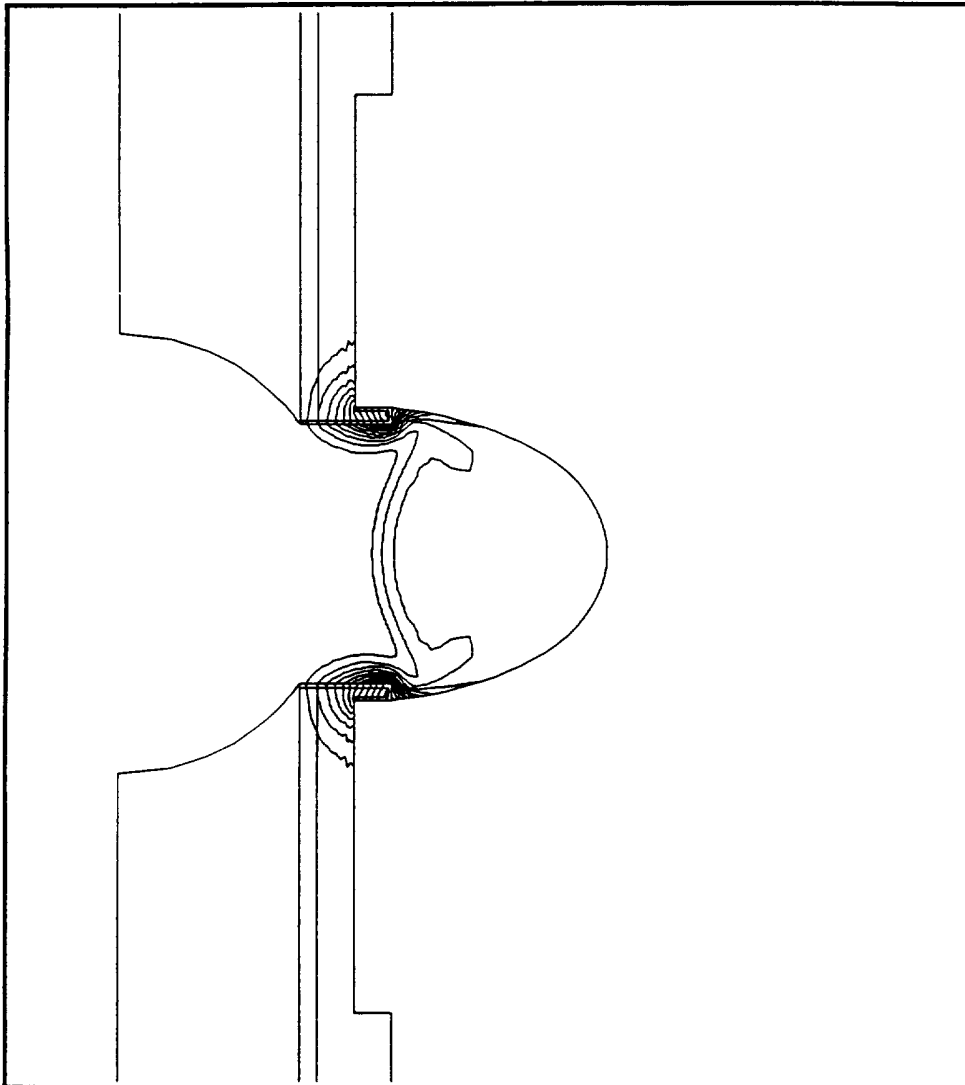

Fig. 2(d)

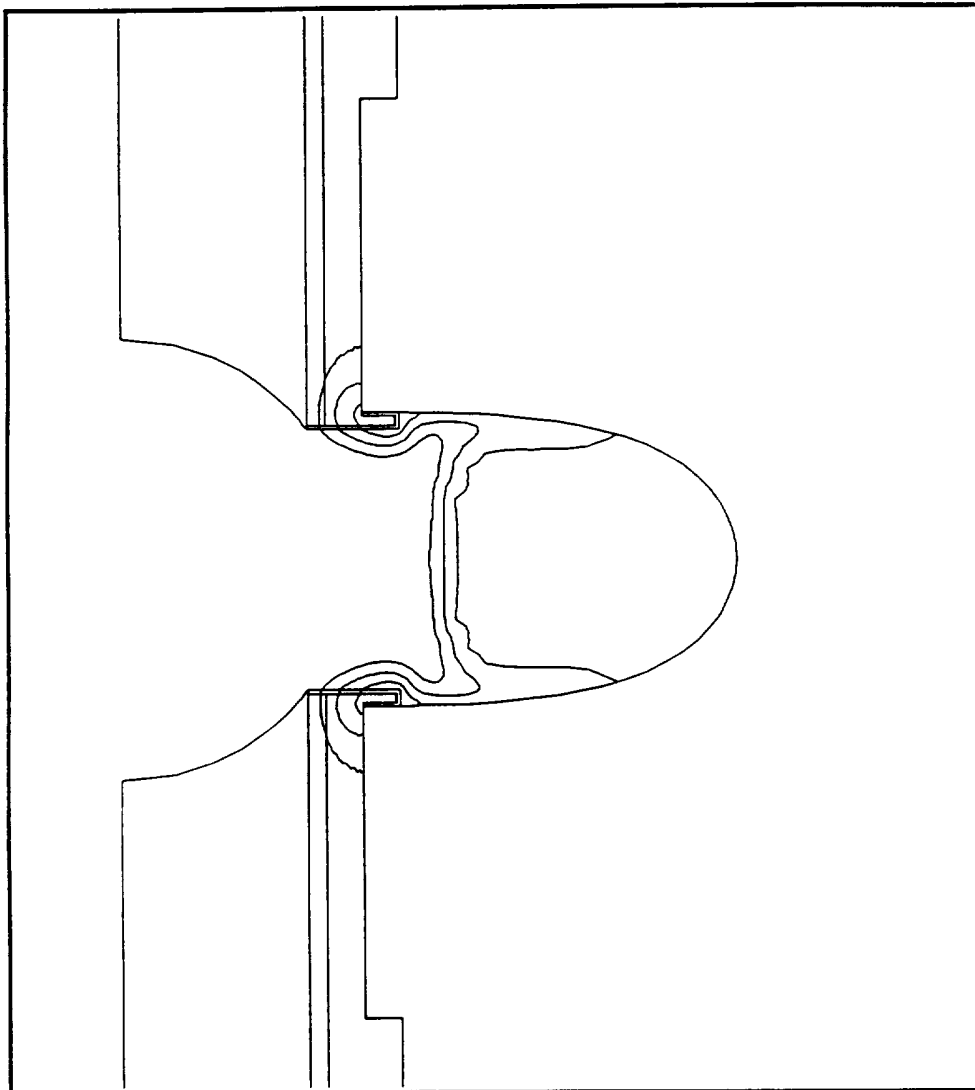

Fig. 2(e)

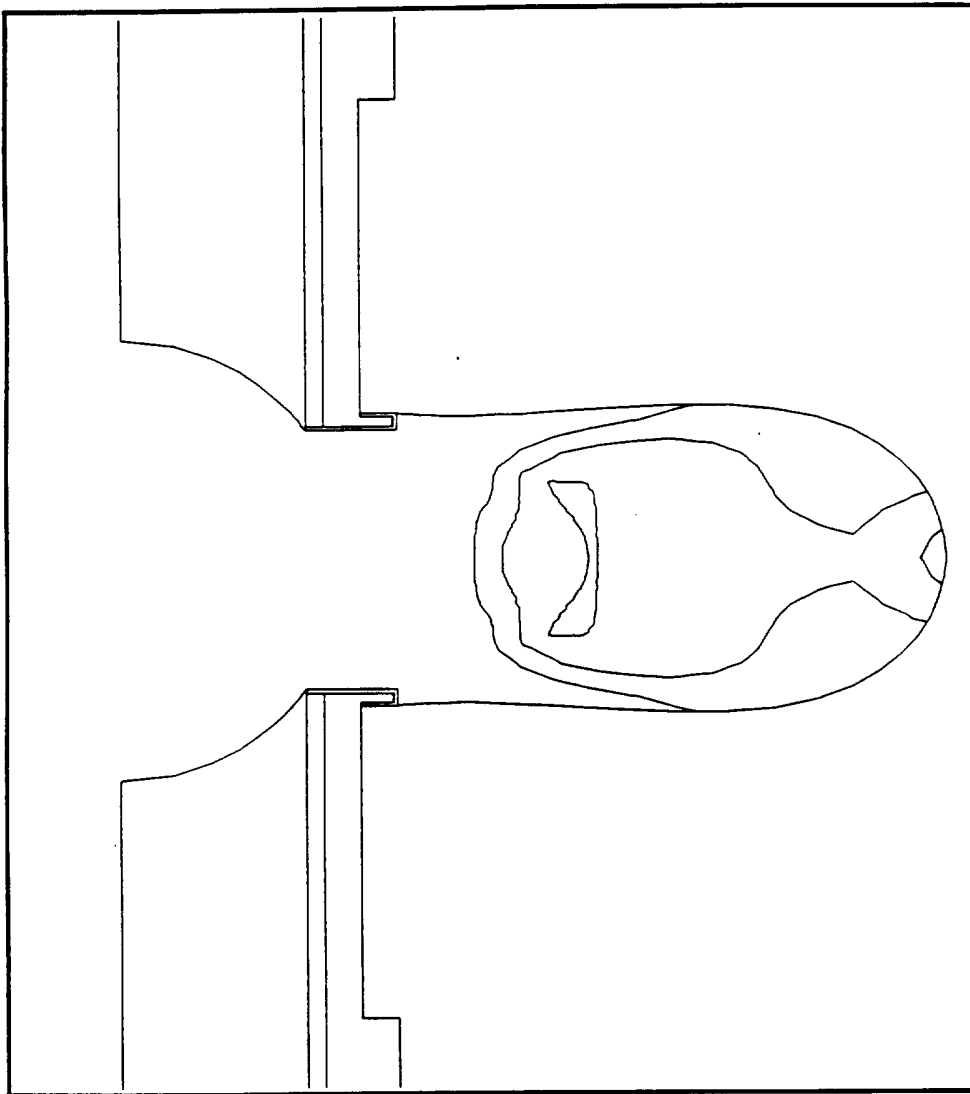

Fig. 2(f)

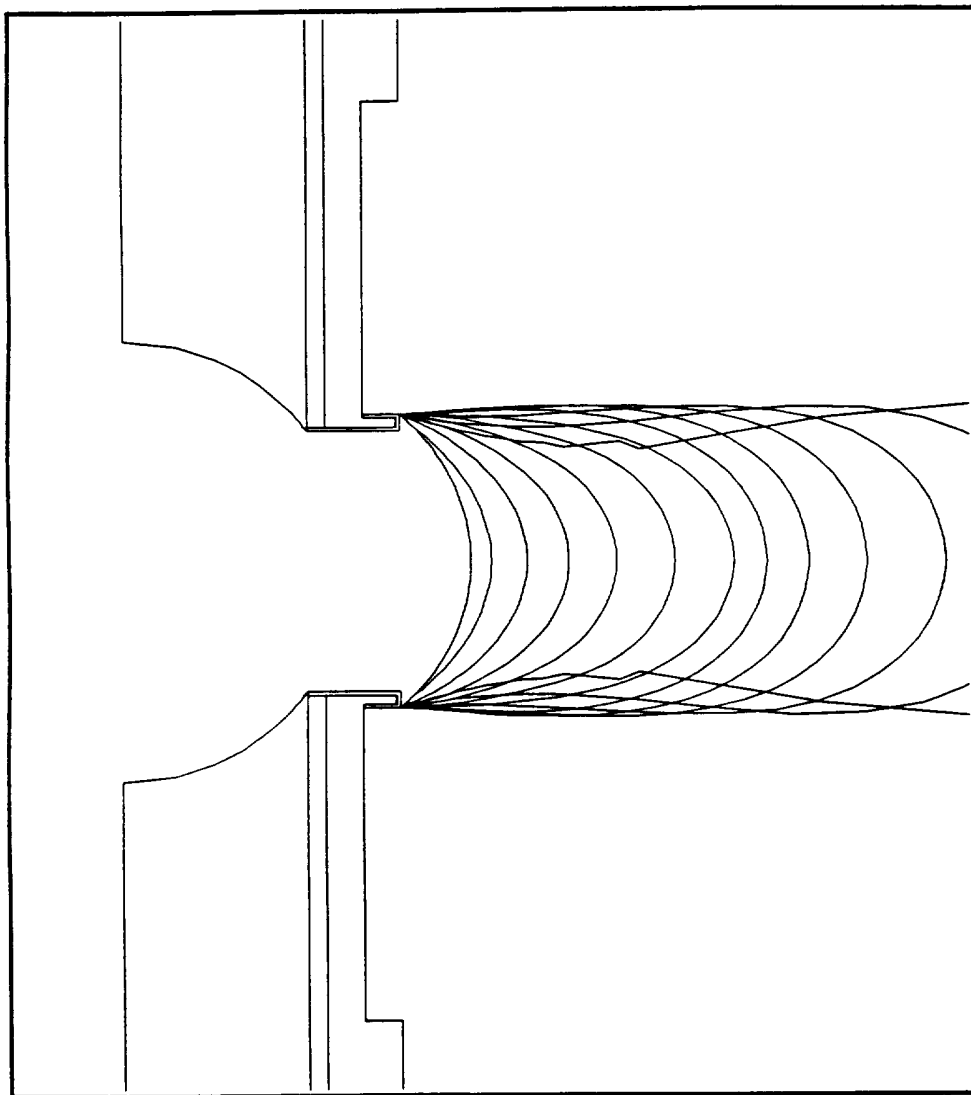

Fig. 3(a)

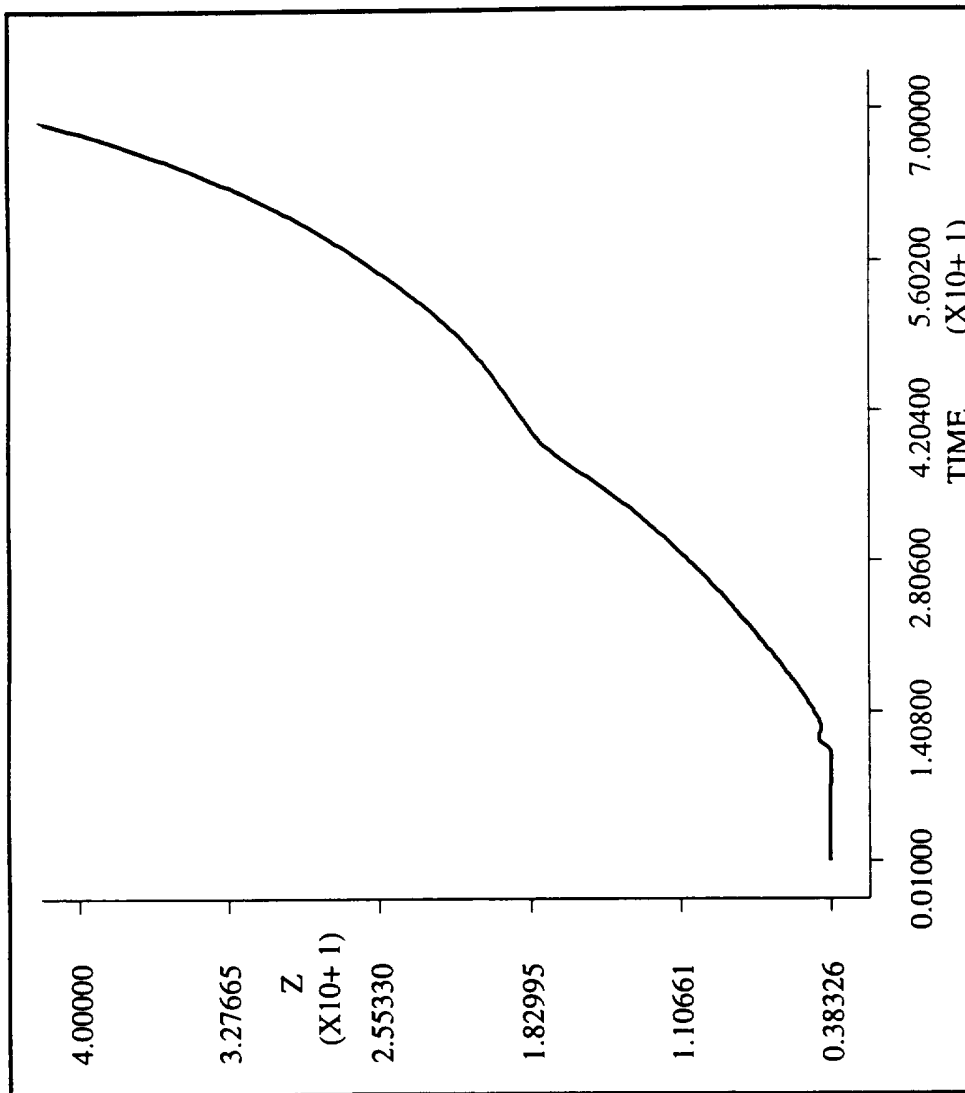

Fig.3(b)

10/28

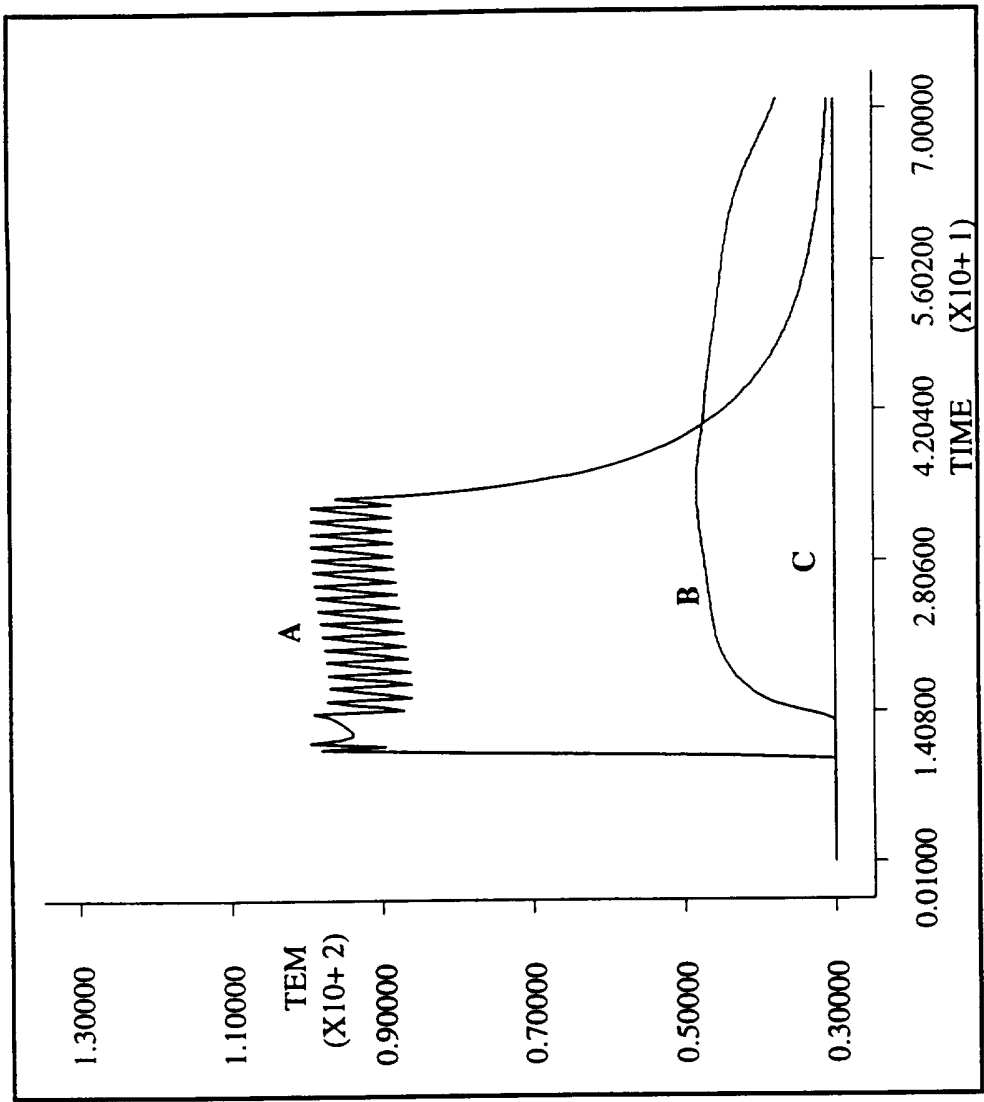

Fig. 3(c)

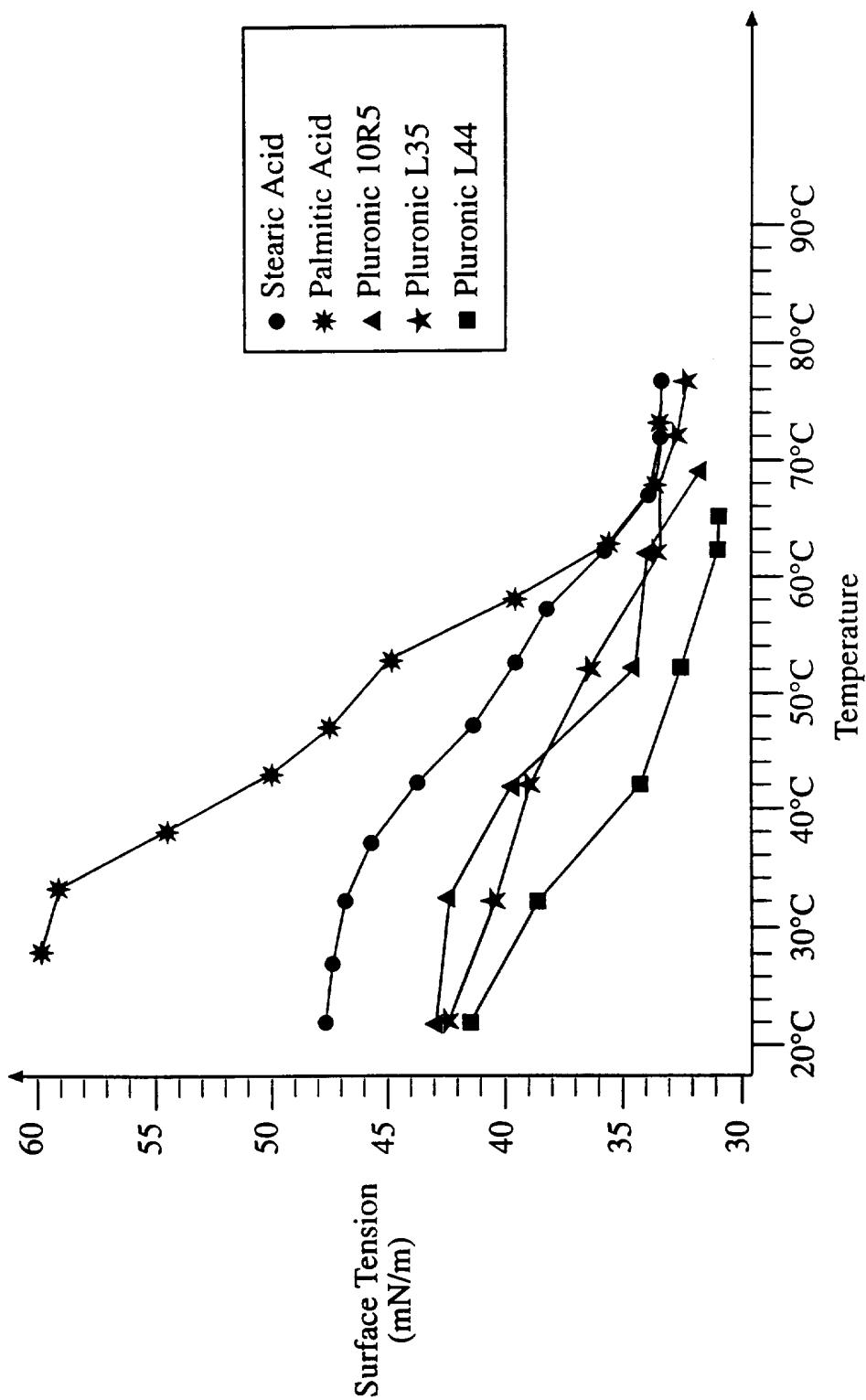

Fig. 3(d)

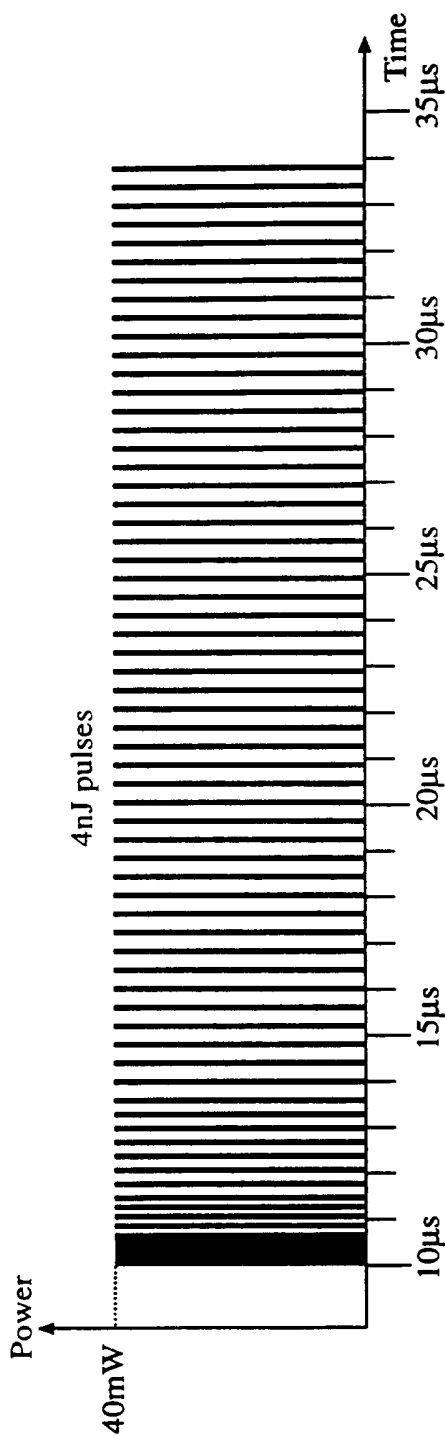

Fig. 3(e)

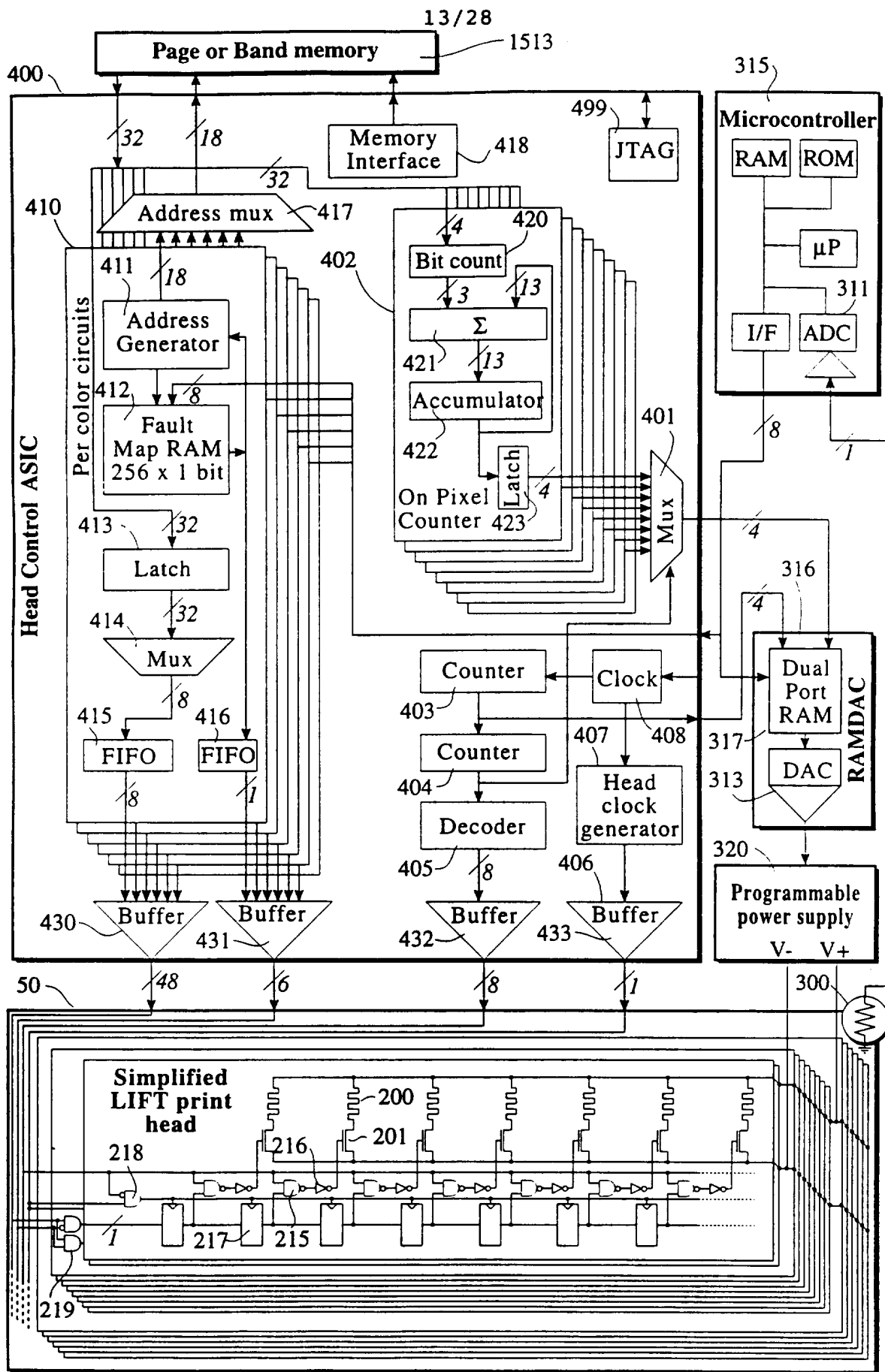

Fig. 4

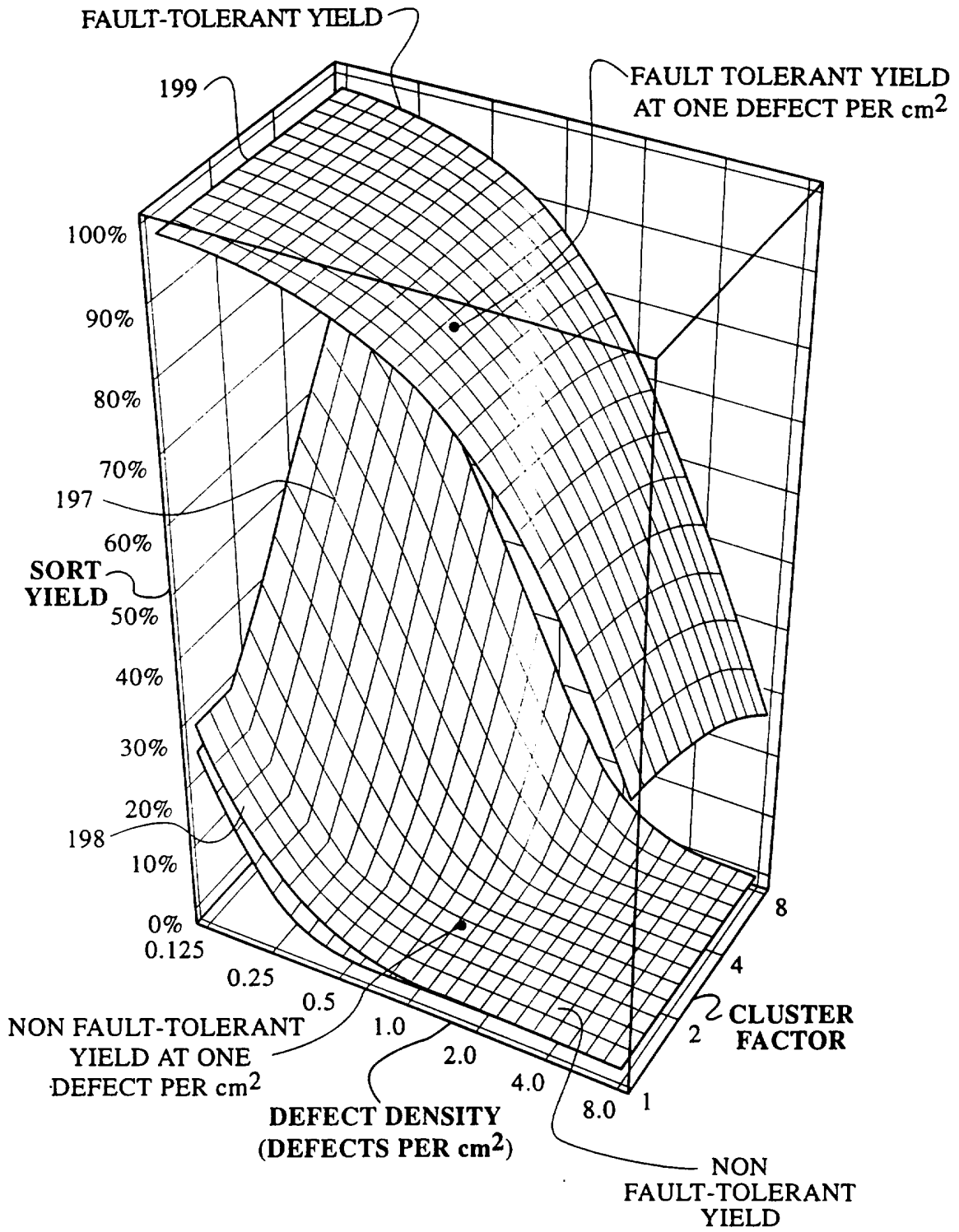

Fig. 5

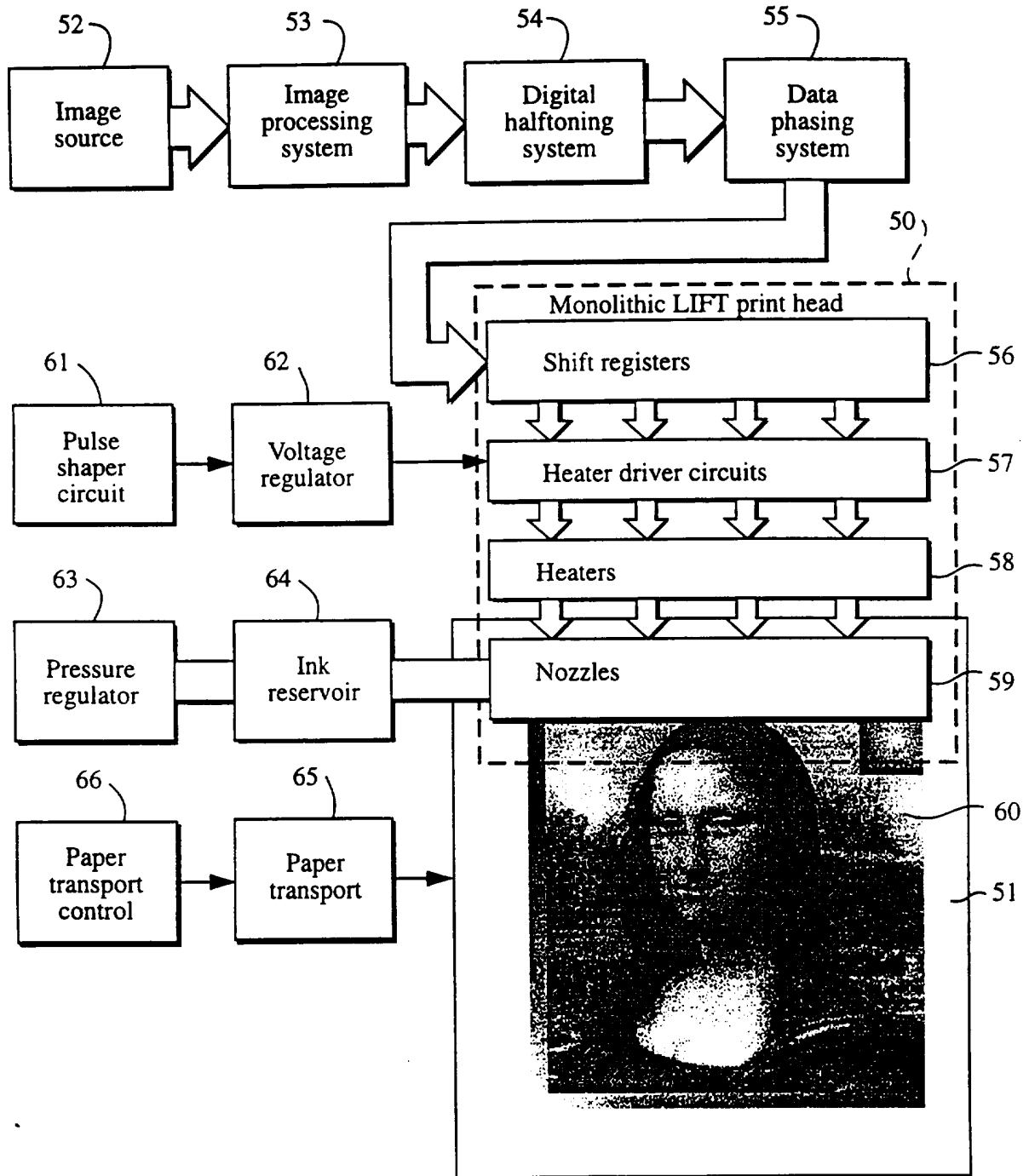

Fig. 6

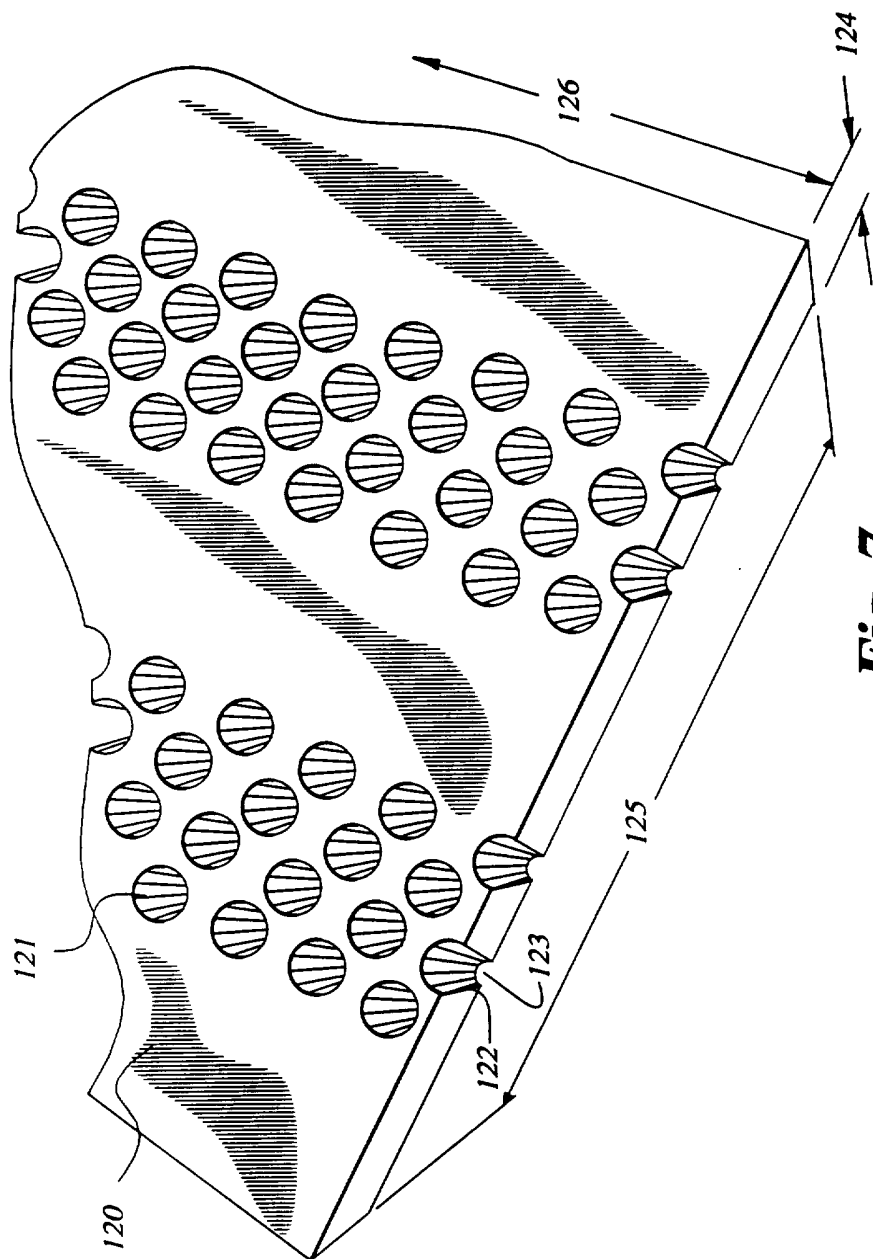

Fig. 7

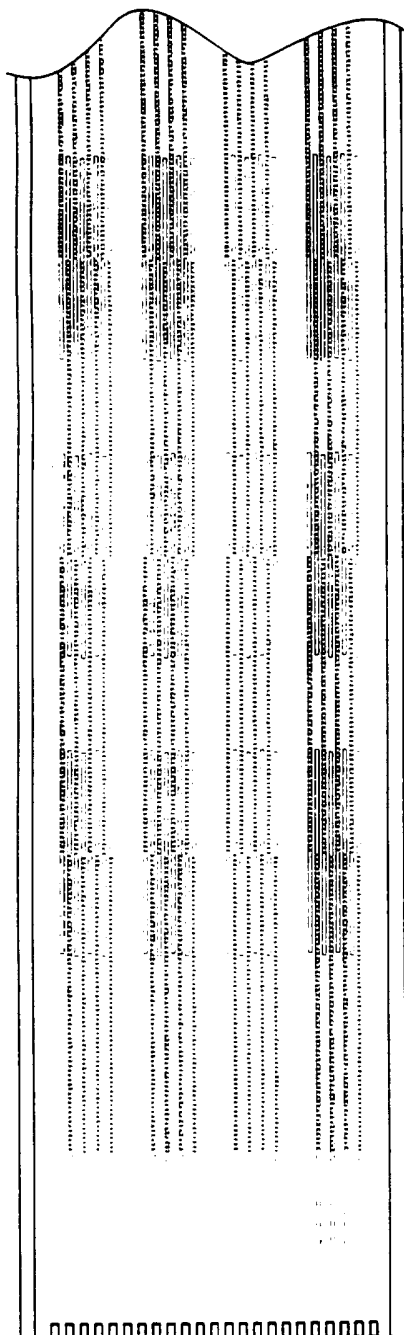

Fig. 8(a)

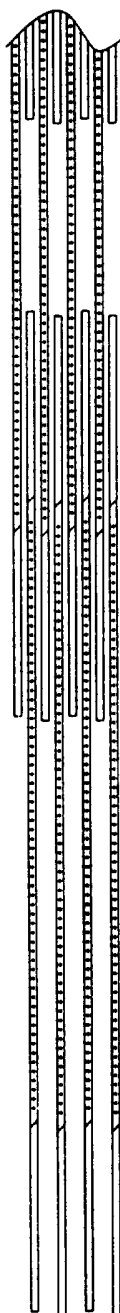

Fig. 8(b)



Fig. 8(c)

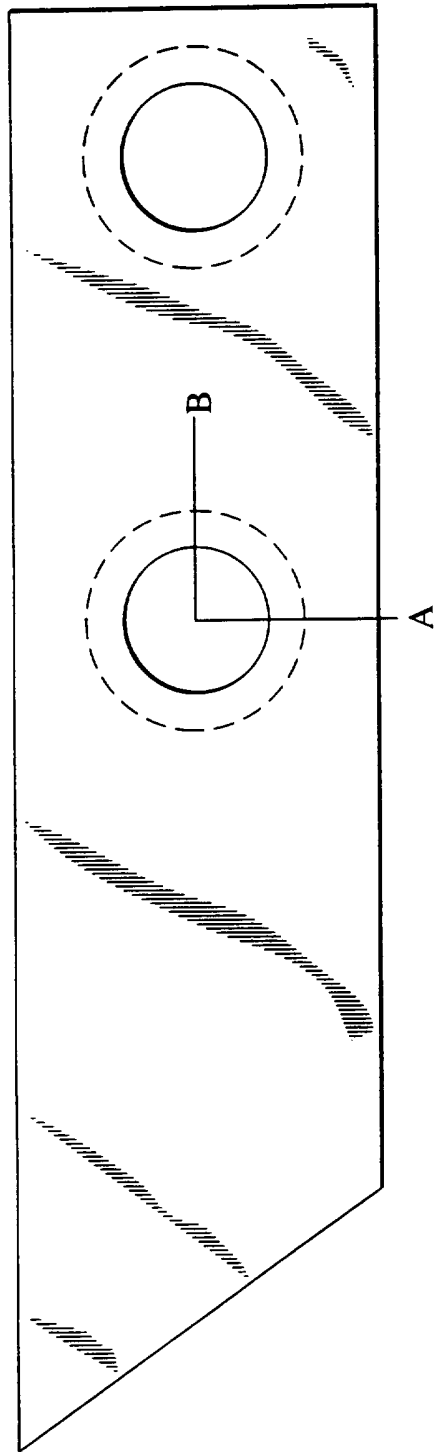

Fig. 8(d)

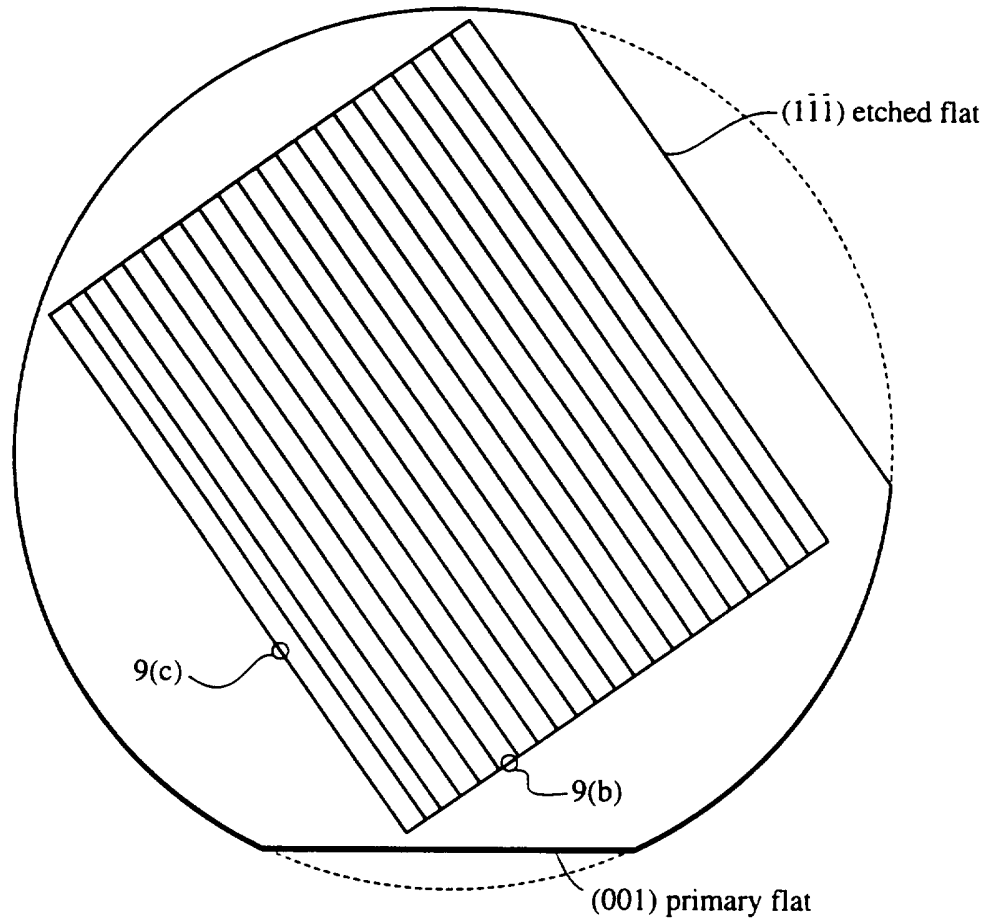

Fig. 9(a)

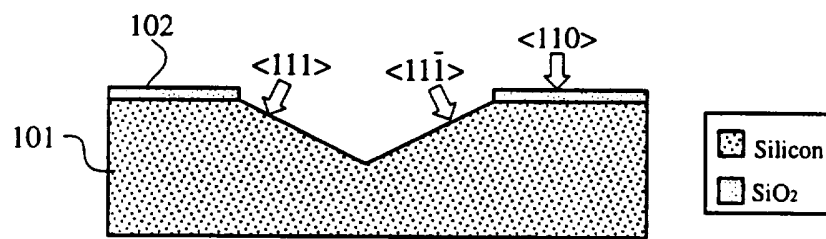

Fig. 9(b)

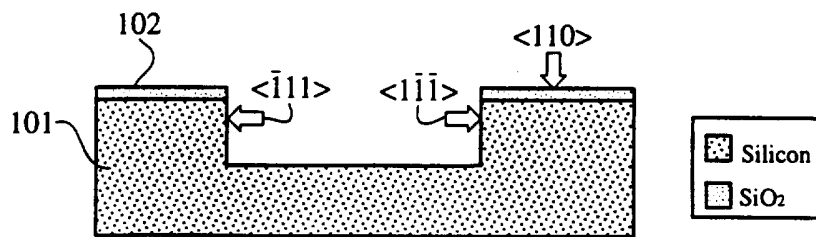

Fig. 9(c)

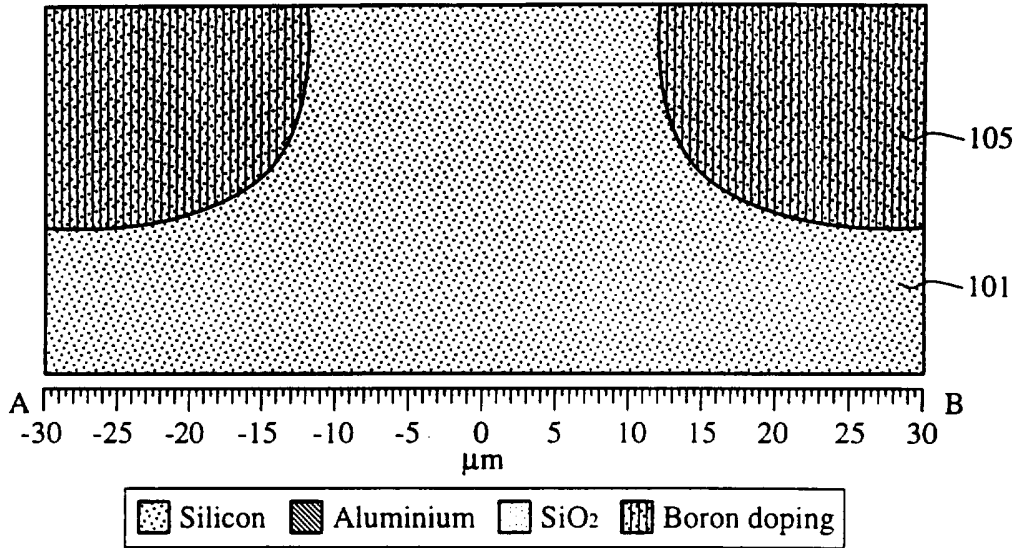

Fig. 9(d)

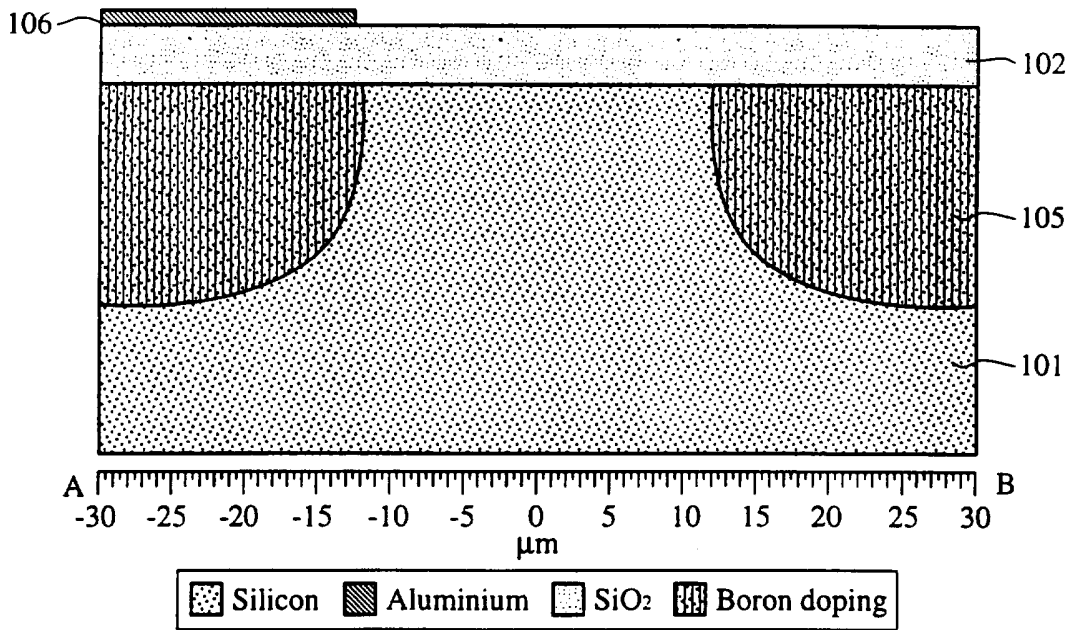

Fig. 9(e)

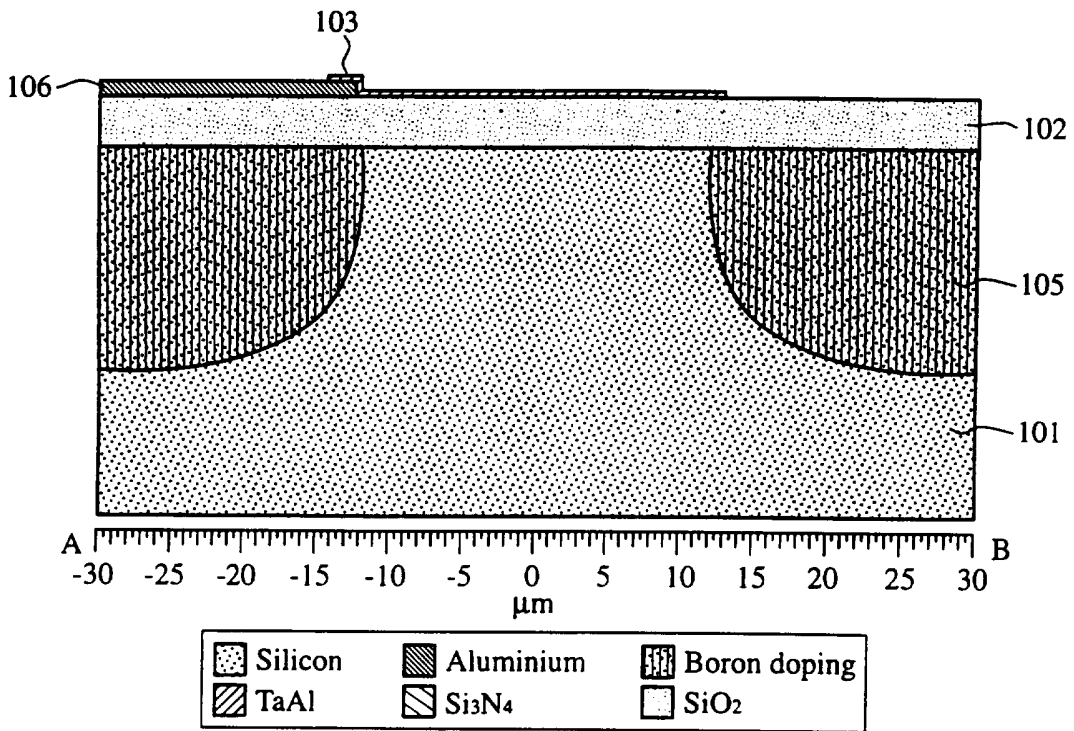

Fig. 9(f)

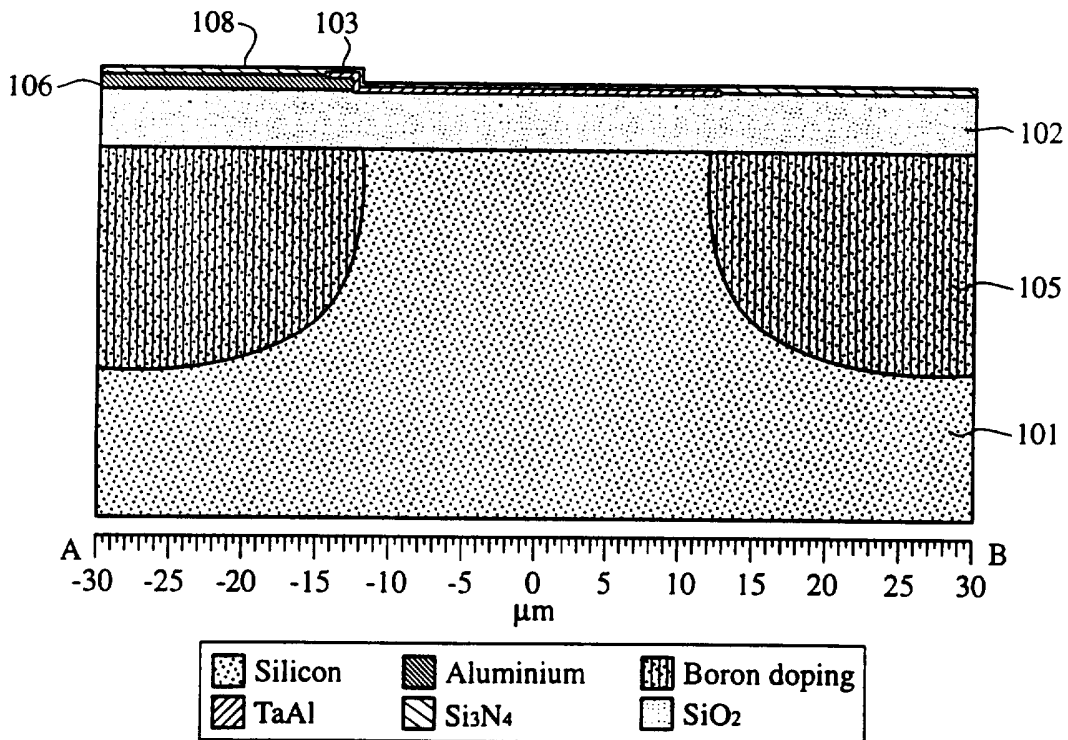

Fig. 9(g)

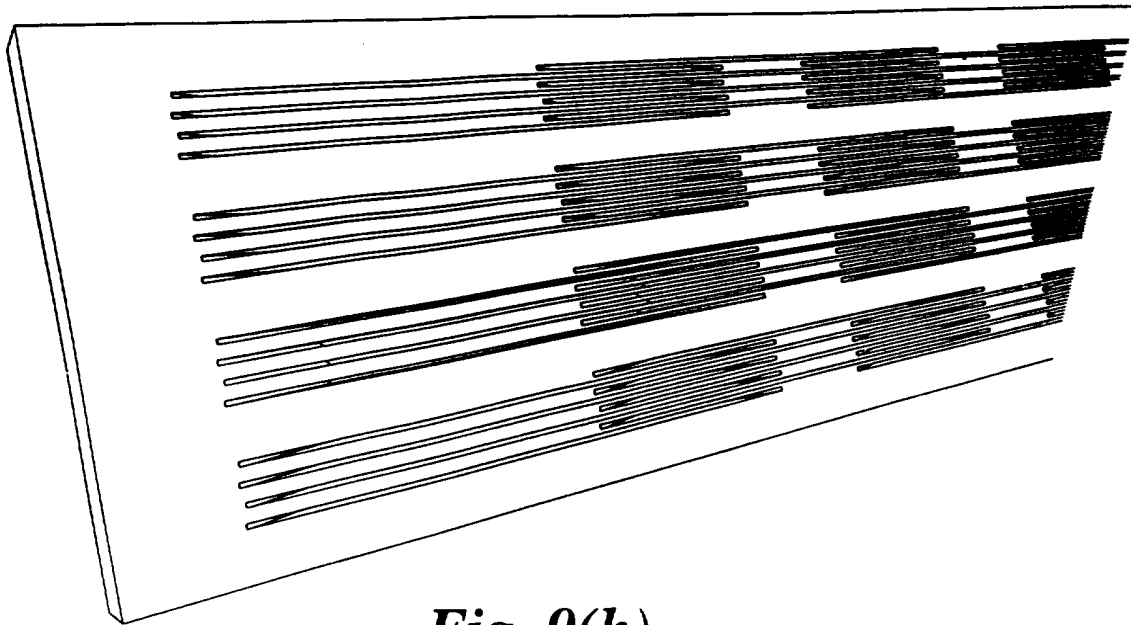

Fig. 9(h)

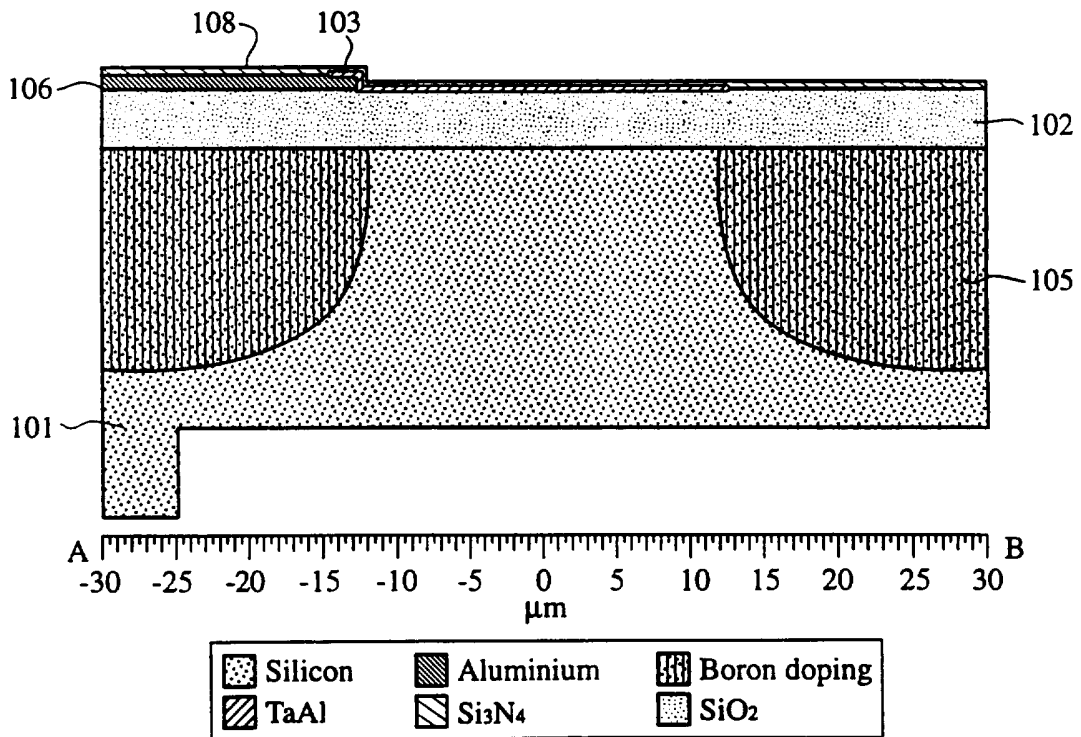

Fig. 9(i)

23/28

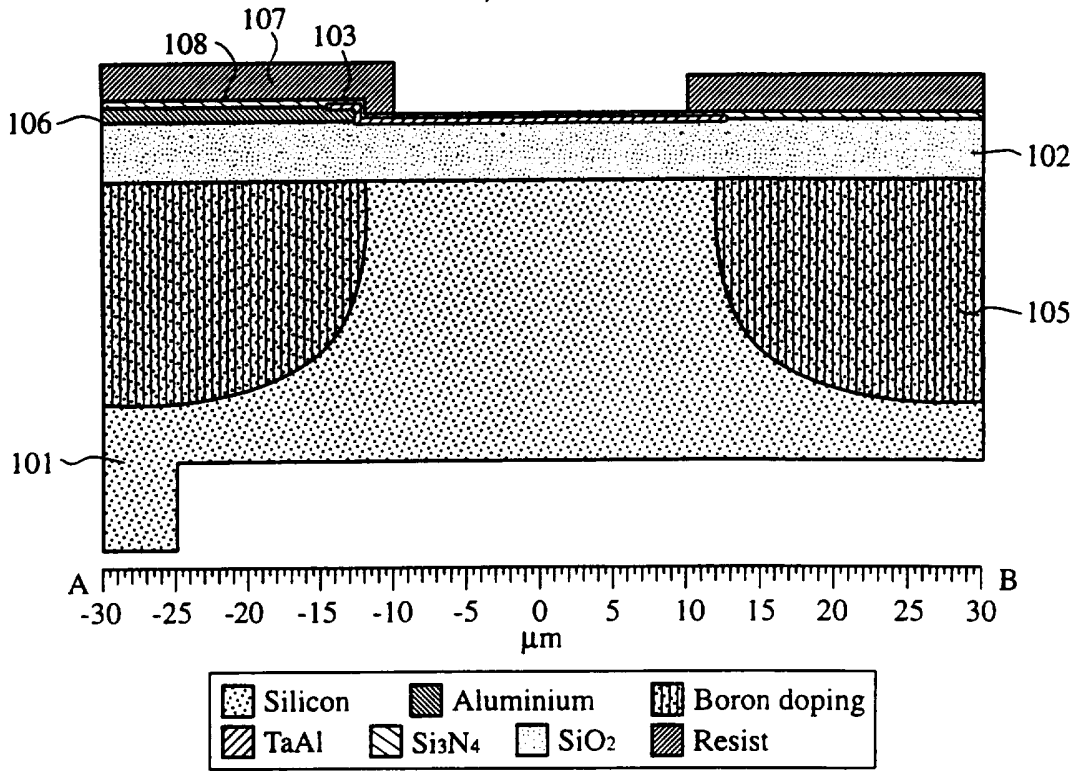

Fig. 9(j)

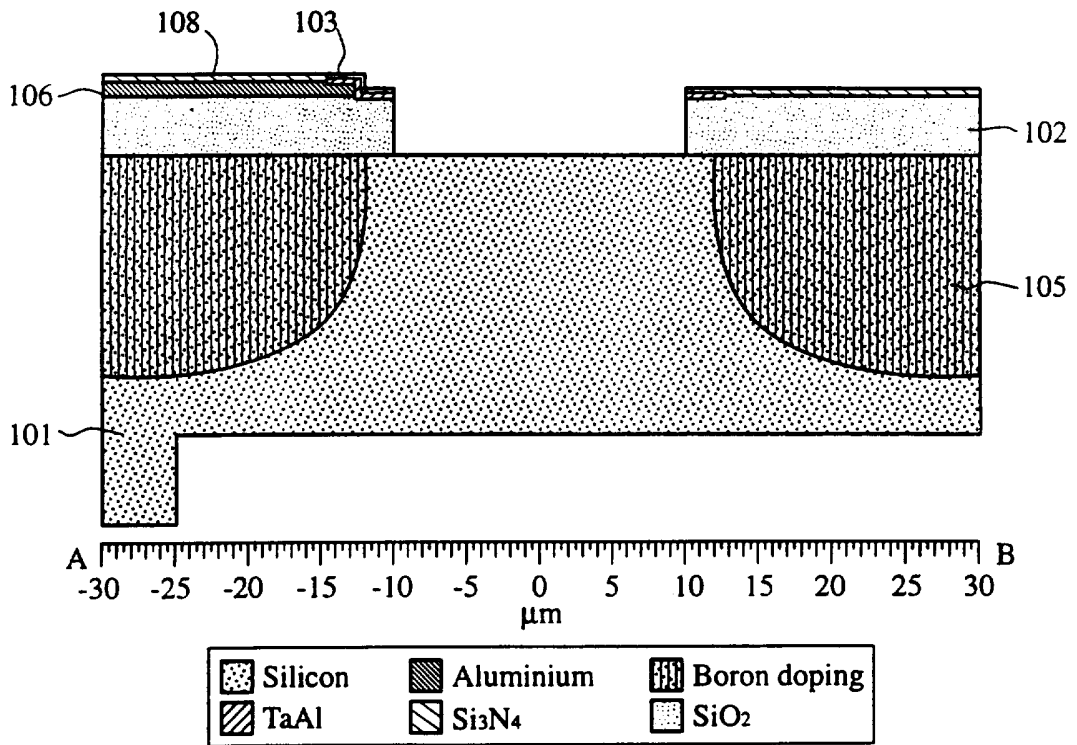

Fig. 9(k)

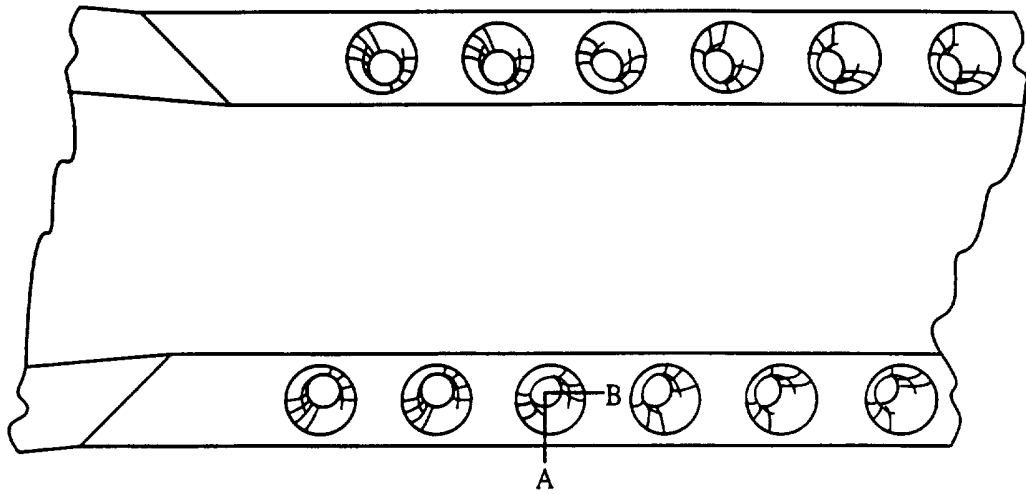

Fig. 9(l)

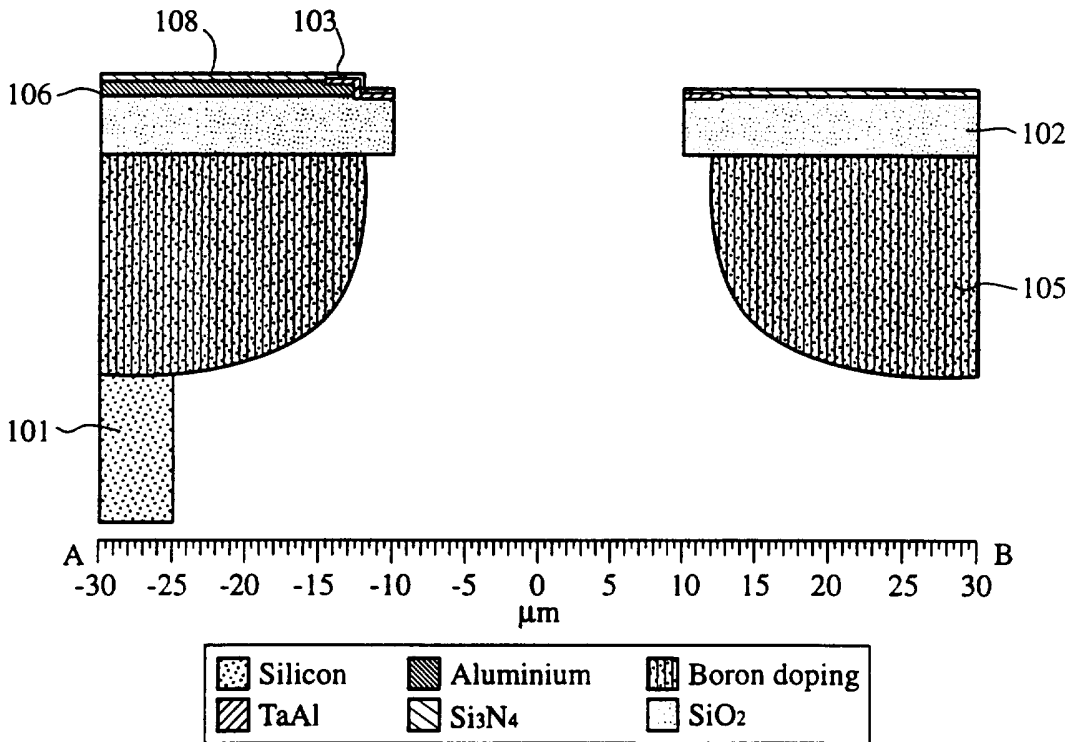

Fig. 9(m)

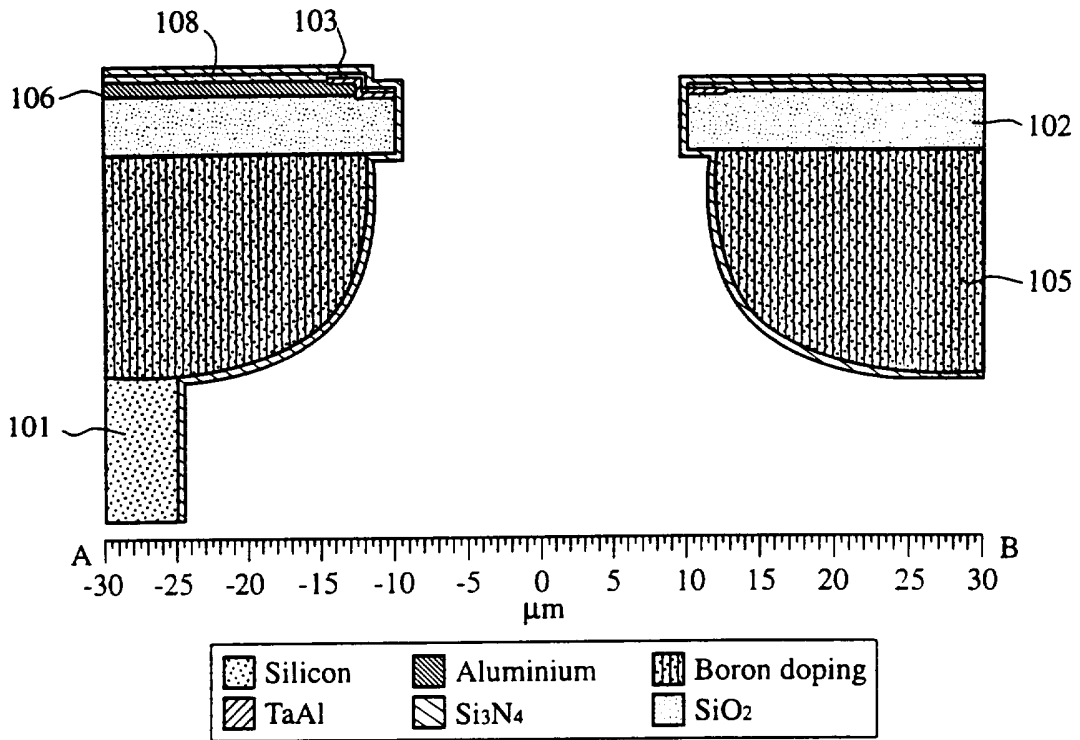

Fig. 9(n)

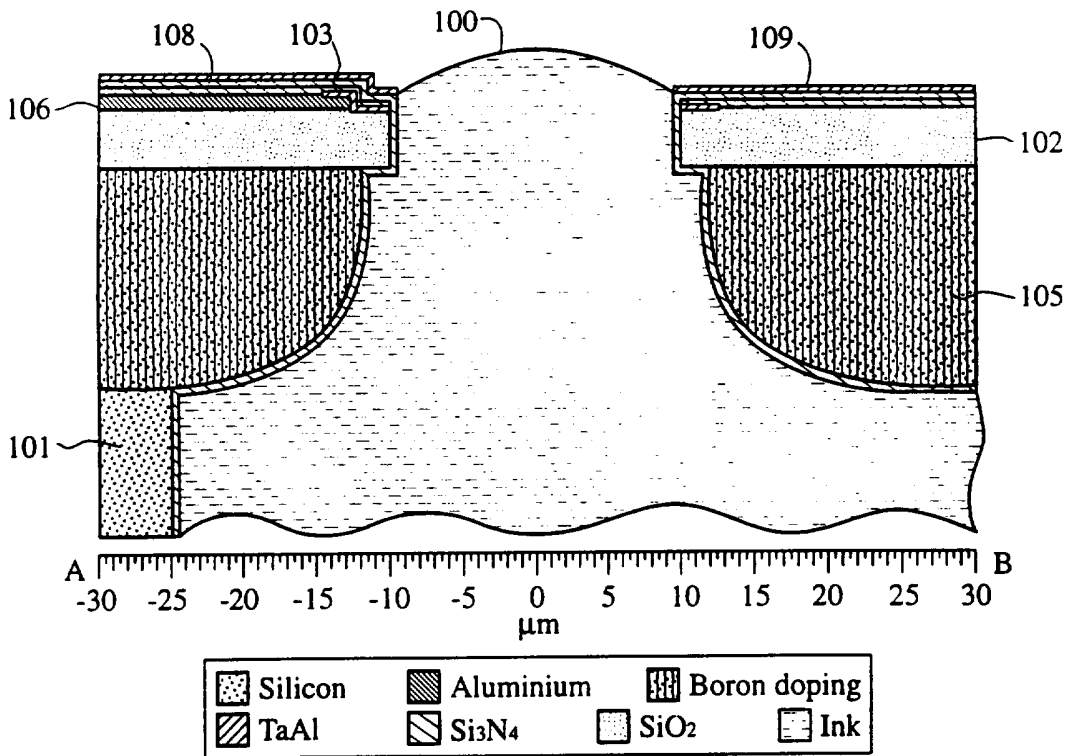

Fig. 9(o)

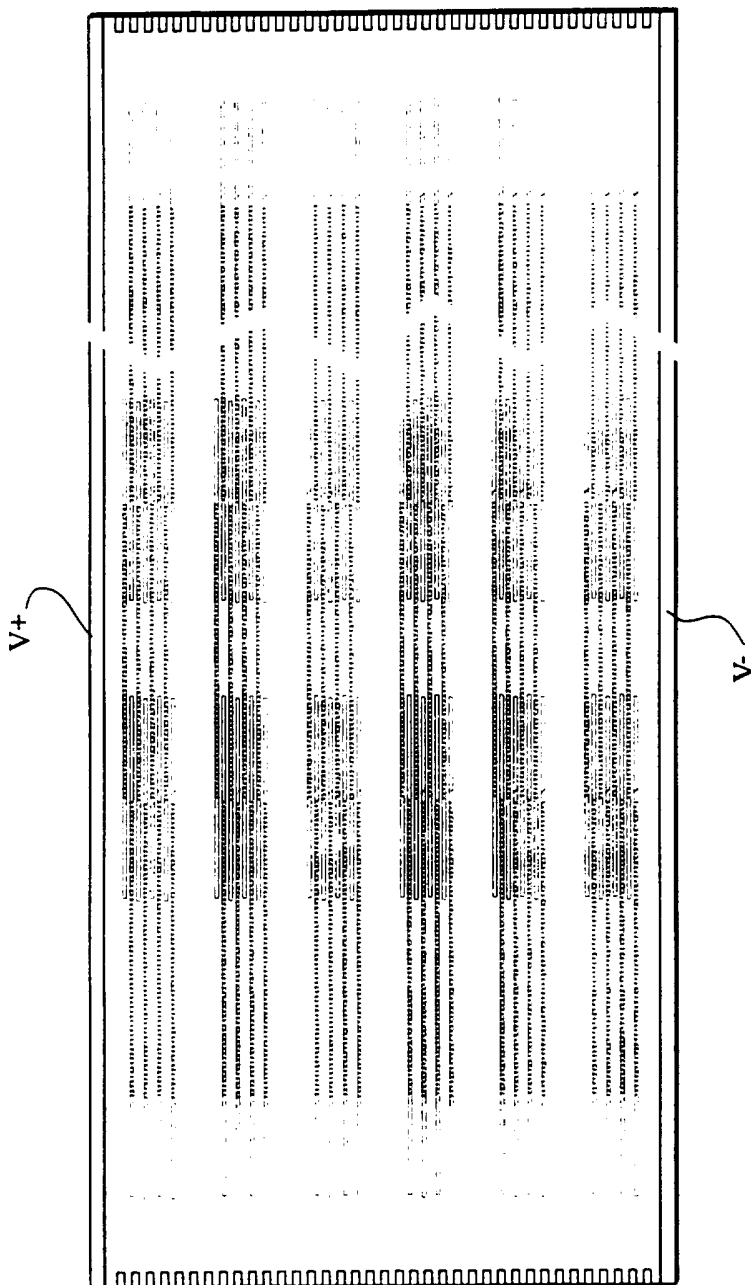

Fig. 10

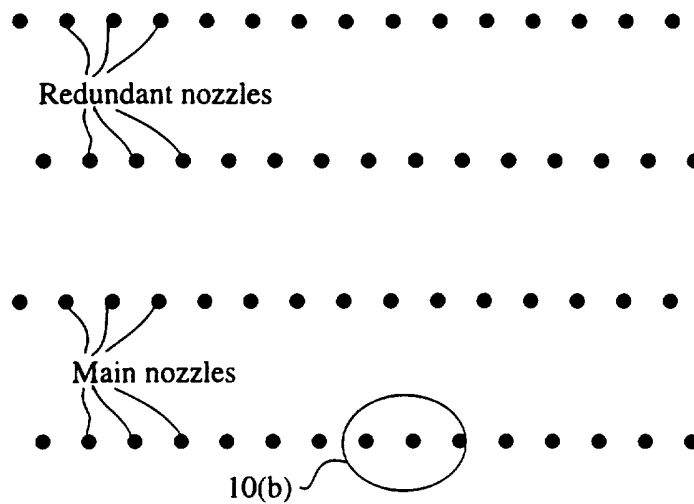
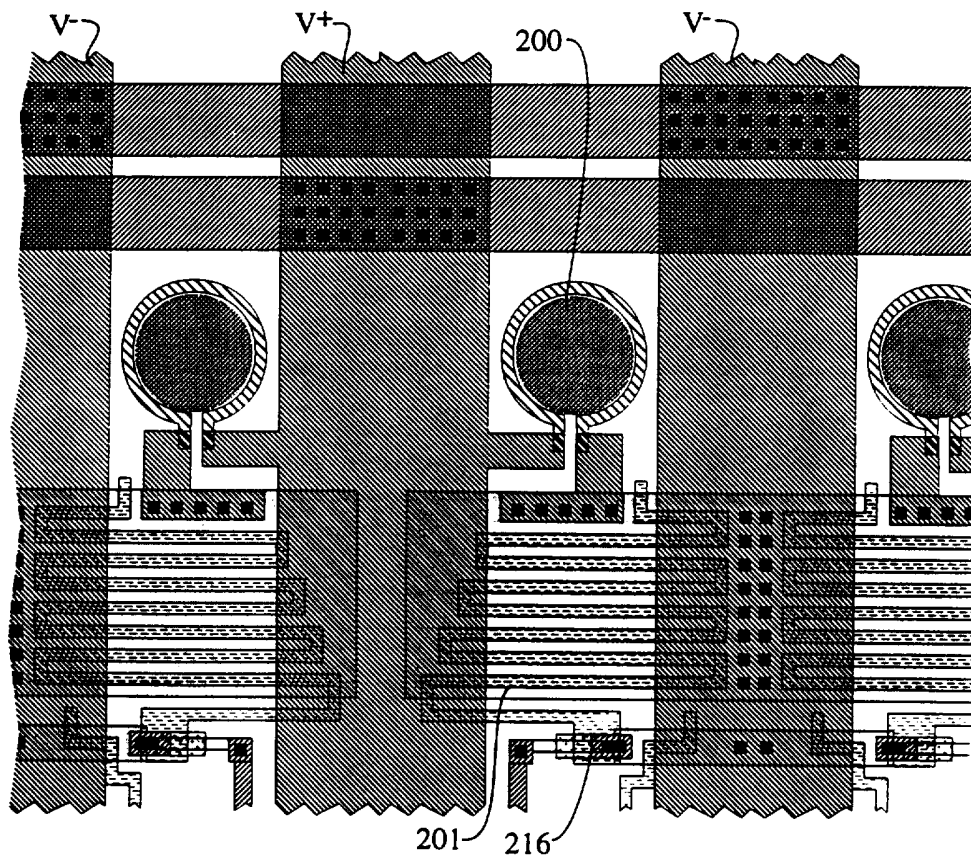

Fig. 11(a)



Polysilicon	Aluminium	Ink	TaAl (Heater)
Vias	Molybdenum	Ion Implantation	Diffusion

Fig. 11(b)

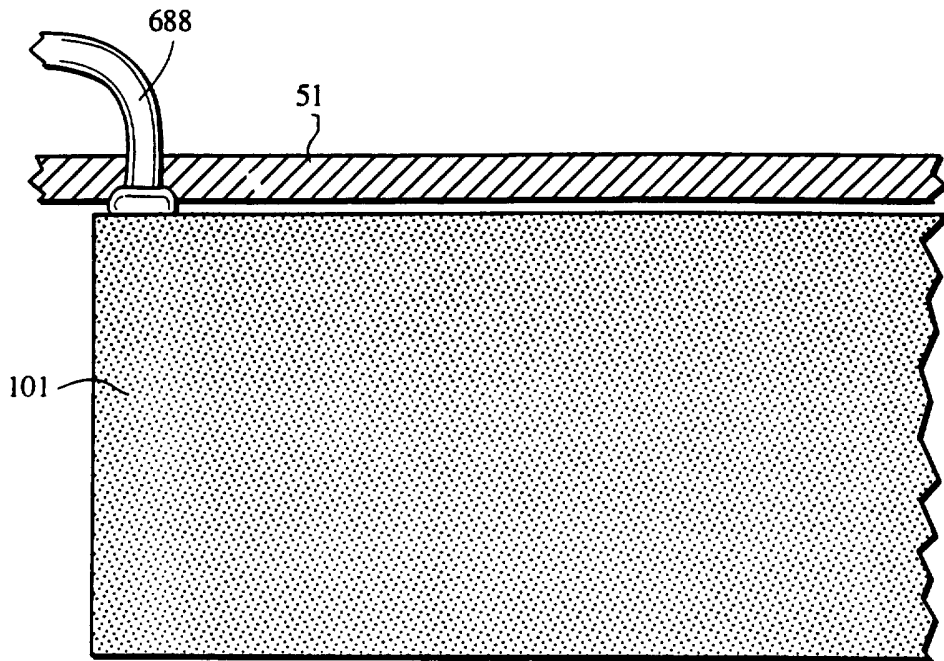

Fig. 12(a)

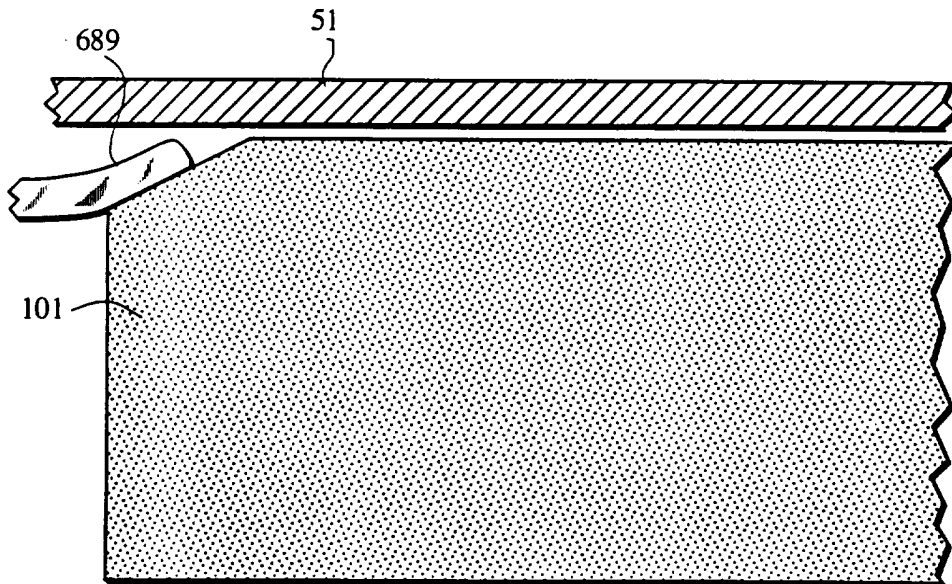

Fig. 12(b)

INTERNATIONAL SEARCH REPORT

International Application No

PCT/US 96/04823

A. CLASSIFICATION OF SUBJECT MATTER
IPC 6 B41J2/14

According to International Patent Classification (IPC) or to both national classification and IPC

B. FIELDS SEARCHED

Minimum documentation searched (classification system followed by classification symbols)
IPC 6 B41J

Documentation searched other than minimum documentation to the extent that such documents are included in the fields searched

Electronic data base consulted during the international search (name of data base and, where practical, search terms used)

C. DOCUMENTS CONSIDERED TO BE RELEVANT

Category *	Citation of document, with indication, where appropriate, of the relevant passages	Relevant to claim No.
X	EP,A,0 498 291 (CANON INFORMATION SYSTEMS) 12 August 1992 see page 14, line 18 - line 33; figure 47 see page 28, line 36	1-5
Y	EP,A,0 600 712 (HEWLETT-PACKARD COMPANY) 8 June 1994 see the whole document	11-16
Y	US,A,4 312 009 (LANGE) 19 January 1982 see the whole document	11-16
Y	US,A,4 164 745 (CIELO ET AL.) 14 August 1979 see the whole document	11-16
Y	US,A,4 752 783 (SAITO ET AL.) 21 June 1988 see the whole document	11-16
	-/--	

Further documents are listed in the continuation of box C.

Patent family members are listed in annex.

* Special categories of cited documents :

- *A* document defining the general state of the art which is not considered to be of particular relevance
- *E* earlier document but published on or after the international filing date
- *L* document which may throw doubts on priority claim(s) or which is cited to establish the publication date of another citation or other special reason (as specified)
- *O* document referring to an oral disclosure, use, exhibition or other means
- *P* document published prior to the international filing date but later than the priority date claimed

- *T* later document published after the international filing date or priority date and not in conflict with the application but cited to understand the principle or theory underlying the invention
- *X* document of particular relevance; the claimed invention cannot be considered novel or cannot be considered to involve an inventive step when the document is taken alone
- *Y* document of particular relevance; the claimed invention cannot be considered to involve an inventive step when the document is combined with one or more other such documents, such combination being obvious to a person skilled in the art.
- *&* document member of the same patent family

Date of the actual completion of the international search

12 September 1996

Date of mailing of the international search report

27.09.96

Name and mailing address of the ISA

European Patent Office, P.B. 5818 Patentlaan 2
NL - 2280 HV Rijswijk
Tel. (+ 31-70) 340-2040, Tx. 31 651 epo nl,
Fax: (+ 31-70) 340-3016

Authorized officer

Meulemans, J-P

INTERNATIONAL SEARCH REPORT

Information on patent family members

International Application No

PCT/US 96/04823

Patent document cited in search report	Publication date	Patent family member(s)	Publication date
EP-A-498291	12-08-92	AT-T- 136500	15-04-96
		AU-A- 8999691	06-08-92
		DE-D- 69209684	15-05-96
		JP-A- 5338178	21-12-93
		AU-A- 8999891	06-08-92
		AU-B- 657720	23-03-95
		AU-A- 9000191	06-08-92
		EP-A- 0498292	12-08-92
		EP-A- 0498293	12-08-92
		JP-A- 6040037	15-02-94
		JP-A- 5338171	21-12-93
		JP-A- 5338172	21-12-93
		AU-B- 657929	30-03-95
AU-B- 667295	21-03-96		
EP-A-600712	08-06-94	US-A- 5381166	10-01-95
		US-A- 5481280	02-01-96
		JP-A- 6293140	21-10-94
US-A-4312009	19-01-82	FR-A- 2448979	12-09-80
		AT-T- 3833	15-07-83
		EP-A- 0014918	03-09-80
US-A-4164745	14-08-79	NONE	
US-A-4752783	21-06-88	JP-B- 7064065	12-07-95
		JP-A- 62225388	03-10-87
		JP-B- 7017062	01-03-95
		JP-A- 62225353	03-10-87
DE-A-2949808	10-07-80	JP-A- 55079175	14-06-80
WO-A-9014233	29-11-90	NONE	
US-A-4293865	06-10-81	JP-C- 1209308	29-05-84
		JP-A- 55049270	09-04-80
		JP-B- 58040512	06-09-83

INTERNATIONAL SEARCH REPORT

Information on patent family members

International Application No

PCT/US 96/04823

Patent document cited in search report	Publication date	Patent family member(s)	Publication date
EP-A-498291	12-08-92	AT-T- 136500	15-04-96
		AU-A- 8999691	06-08-92
		DE-D- 69209684	15-05-96
		JP-A- 5338178	21-12-93
		AU-A- 8999891	06-08-92
		AU-B- 657720	23-03-95
		AU-A- 9000191	06-08-92
		EP-A- 0498292	12-08-92
		EP-A- 0498293	12-08-92
		JP-A- 6040037	15-02-94
		JP-A- 5338171	21-12-93
		JP-A- 5338172	21-12-93
		AU-B- 657929	30-03-95
AU-B- 667295	21-03-96		

EP-A-600712	08-06-94	US-A- 5381166	10-01-95
		US-A- 5481280	02-01-96
		JP-A- 6293140	21-10-94

US-A-4312009	19-01-82	FR-A- 2448979	12-09-80
		AT-T- 3833	15-07-83
		EP-A- 0014918	03-09-80

US-A-4164745	14-08-79	NONE	

US-A-4752783	21-06-88	JP-B- 7064065	12-07-95
		JP-A- 62225388	03-10-87
		JP-B- 7017062	01-03-95
		JP-A- 62225353	03-10-87

DE-A-2949808	10-07-80	JP-A- 55079175	14-06-80

WO-A-9014233	29-11-90	NONE	

US-A-4293865	06-10-81	JP-C- 1209308	29-05-84
		JP-A- 55049270	09-04-80
		JP-B- 58040512	06-09-83
