

(19) World Intellectual Property Organization  
International Bureau



(43) International Publication Date  
18 June 2009 (18.06.2009)

PCT

(10) International Publication Number  
**WO 2009/074912 A2**

- (51) International Patent Classification:  
A62B 18/02 (2006.01)
- (21) International Application Number:  
PCT/IB2008/055031
- (22) International Filing Date:  
1 December 2008 (01.12.2008)
- (25) Filing Language: English
- (26) Publication Language: English
- (30) Priority Data:  
12/002,064 13 December 2007 (13.12.2007) US
- (71) Applicant (for all designated States except US): **KIMBERLY-CLARK WORLDWIDE, INC.** [US/US]; 401 N. Lake Street, Neenah, Wisconsin 54956 (US).
- (72) Inventors; and
- (75) Inventors/Applicants (for US only): **WELCHEL, Debra, N.** [US/US]; 1350 Chatley Way, Woodstock, Georgia 30188 (US). **STEINDORE, Eric, C.** [US/US]; 1120 Falstaff Drive, Roswell, Georgia 30076 (US).
- (74) Agents: **STOKER, Denise, L.** et al.; Kimberly-clark Worldwide, Inc., 401 N. Lake Street, Neenah, Wisconsin 54956 (US).
- (81) Designated States (unless otherwise indicated, for every kind of national protection available): AE, AG, AL, AM, AO, AT, AU, AZ, BA, BB, BG, BH, BR, BW, BY, BZ, CA, CH, CN, CO, CR, CU, CZ, DE, DK, DM, DO, DZ, EC, EE, EG, ES, FI, GB, GD, GE, GH, GM, GT, HN, HR, HU, ID, IL, IN, IS, JP, KE, KG, KM, KN, KP, KR, KZ, LA, LC, LK, LR, LS, LT, LU, LY, MA, MD, ME, MG, MK, MN, MW, MX, MY, MZ, NA, NG, NI, NO, NZ, OM, PG, PH, PL, PT, RO, RS, RU, SC, SD, SE, SG, SK, SL, SM, ST, SV, SY, TJ, TM, TN, TR, TT, TZ, UA, UG, US, UZ, VC, VN, ZA, ZM, ZW.
- (84) Designated States (unless otherwise indicated, for every kind of regional protection available): ARIPO (BW, GH, GM, KE, LS, MW, MZ, NA, SD, SL, SZ, TZ, UG, ZM, ZW), Eurasian (AM, AZ, BY, KG, KZ, MD, RU, TJ, TM), European (AT, BE, BG, CH, CY, CZ, DE, DK, EE, ES, FI, FR, GB, GR, HR, HU, IE, IS, IT, LT, LU, LV, MC, MT, NL,

[Continued on next page]

(54) Title: RESPIRATOR WITH STRETCH-PANELS

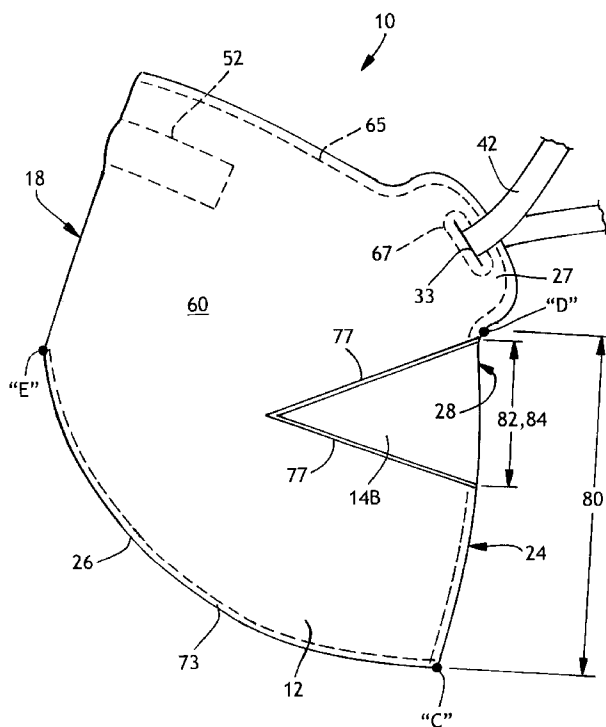

FIG. 6

(57) Abstract: A disposable respirator made from a filter body having at least one stretch-panel incorporated therein. The stretch-panel allows the respirator to better conform to the wearer's face during movement due to talking, coughing, or general head or neck movement. There may be one or more stretch-panels located underneath the chin or over the cheeks of the wearer.

WO 2009/074912 A2



---

NO, PL, PT, RO, SE, SI, SK, TR), OAPI (BF, BJ, CF, CG,  
CI, CM, GA, GN, GQ, GW, ML, MR, NE, SN, TD, TG).

**Published:**

- *without international search report and to be republished  
upon receipt of that report*

## RESPIRATOR WITH STRETCH-PANELS

### BACKGROUND OF THE INVENTION

5 The invention relates to filter masks which isolate both the mouth and nostrils of a wearer from the surrounding environment. More particularly, the invention relates to a conforming, collapsible filter mask which requires only a headband to secure the filter mask to the wearer's head.

10 There are many situations today where it is necessary to filter the air which is inhaled and exhaled. Such filtration is primarily concerned with removal of small particulate matter, such as dirt or bacteria, as opposed to gases or liquids, from the air. Perhaps the most common instance in which a filter mask is used is in the medical arts. However, the same filter masks which have application in the  
15 medical arts are also, in many cases, well suited for use in industrial and domestic applications.

In the medical arts, filter masks are often used to prevent substances exhaled by the wearer from entering the surrounding environment. The same mask may also  
20 be used to protect the wearer from inhaling harmful microorganisms. One of the more common applications of filter masks in the medical arts is the wearing of masks by a surgical team while performing surgical procedures. A mask worn during surgical procedures, for example, desirably provides proper air filtration while still being comfortable for the wearer who may be wearing the same mask for  
25 several hours.

In the industrial arts it is often necessary for individuals working in "clean room" environments to avoid the introduction of any substances which may be exhaled by the wearer, into the clean room environment. As in the medical arts  
30 applications, industrial applications may require the workers to wear their filter masks for extended periods of time. Therefore, it is desirable that a mask be comfortable and durable.

Other industrial applications require the filtration of the air which is inhaled by the wearer. Often construction or agricultural workers will be working in a "dirty" environment in which the air would be harmful to breathe if it were not filtered. Many times filter masks are used in such circumstances to protect the wearer from  
5 harm. Unfortunately, many workers will simply go without a protective mask if they deem it too uncomfortable.

Besides the medical and industrial applications there are domestic applications for such masks in the home such as home improvement projects, particularly those  
10 involving sanding or cutting, yard work, and many hobbies.

Regardless of the application, the full benefits of the filter mask will not be realized if inhaled or exhaled air is allowed to leak around the edges of the mask when held against the wearer's face. However, it is challenging to construct a mask that will  
15 fit the facial configuration of all wearers without constructing the mask specifically for each individual face. Compounding this challenge is the fact that a wearer's face naturally moves and changes in shape while wearing a mask. This can happen when the wearer talks, chews, yawns, stretches, or the like.

It is therefore very desirable to design a mask that is relatively quick and easy to  
20 place on the face, and that will remain in the proper position while the wearer continues his or her ordinary activities. It is further desirable to design a mask that is compact. Generally, a flat storage configuration provides for the most compact storage. Moreover, it is desirable that a mask be economical, since most users of  
25 filter masks dispose of the mask after limited use.

## **SUMMARY OF THE INVENTION**

The present invention includes a disposable respirator which defines an area surrounded by a periphery, the disposable respirator extending across a wearer's  
30 nose bridge, across each of the wearer's cheeks, and underneath the wearer's chin for covering the nose and mouth of the wearer. The disposable respirator includes a filter body comprising a non-elastic material defining a first area, and a first stretch-panel having an outer edge defining a portion of the mask periphery,

the first stretch-panel defining a second area. The first stretch-panel is an elastic material. The area of the first stretch-panel is less than the area of the filter body.

5 In another aspect of the present invention, the respirator is made with a filter body sized to fit over the mouth and nose of the wearer, the filter body having a top edge arranged to extend across the nose and cheeks of the wearer, a bottom edge arranged to extend along a wearer's jaw line, and a seam edge arranged to extend between the wearer's nose to the wearer's chin; and a triangular elastic panel attached to the bottom edge of the filter body, wherein the stretch-panel is  
10 arranged to fit underneath the wearer's chin.

In yet another aspect of the present invention, the respirator is made from a filter body sized to fit over the mouth and nose of the wearer, the filter body having a top edge arranged to extend across a nose and upper cheeks of the wearer; a bottom  
15 edge arranged to extend along lower cheeks and underneath a chin of the wearer, wherein the bottom edge has two spaced apart notched portions; and a seam edge arranged to extend between the wearer's nose to the wearer's chin; and a stretch-panel disposed within each of the of notched portions and attached to the filter body.  
20

Other aspects and features will be in part apparent and in part pointed out hereinafter.

### **BRIEF DESCRIPTION OF THE DRAWINGS**

25 A full and enabling disclosure of the present invention, including the best mode thereof, directed to one of ordinary skill in the art, is set forth more particularly in the remainder of the specification, which makes reference to the appended figures in which:

30 FIG. 1 is a side elevation of one embodiment of the respirator of the present invention in a flat folded configuration.

FIG. 2 is an exploded plan view of the various parts used to construct the respirator of FIG. 1, prior to assembly.

5 FIG. 3 is a rear elevation of the respirator shown in FIG. 1, in an unfolded configuration.

FIG. 4 is a front perspective view of the respirator in FIG. 1 shown on the face of a wearer with his head in a rearward tilt position.

10 FIG. 5 is a front perspective view of the respirator of FIG. 1, shown on the face of a wearer with his head in an upright position.

FIG. 6 is a front elevation of a second embodiment of the respirator of the present invention in a flat-fold configuration.

15

FIG. 7 is a side elevation of a second embodiment of the respirator of the present invention shown on the face of a wearer.

FIG. 8 is a side elevation of a third embodiment of the respirator of the present invention.

20

FIG. 9 is a side elevation of a fourth embodiment of the respirator of the present invention.

25 FIG. 10 is a side elevation of a fifth embodiment of the respirator of the present invention.

## **DETAILED DESCRIPTION OF THE PRESENT INVENTION**

The following definitions are used in the description of the present invention.

30

“Attach” and its derivatives refer to the joining, adhering, connecting, bonding, sewing together, or the like, of two elements. Two elements will be considered to be attached together when they are integral with one another or attached directly

to one another or indirectly to one another, such as when each is directly attached to intermediate elements. "Attach" and its derivatives include permanent, releasable, or refastenable attachment. In addition, the attachment can be completed either during the manufacturing process or by the end user.

5

"Connect" and its derivatives refer to the joining, adhering, bonding, attaching, sewing together, or the like, of two elements. Two elements will be considered to be connected together when they are connected directly to one another or indirectly to one another, such as when each is directly connected to intermediate elements. "Connect" and its derivatives include permanent, releasable, or refastenable connection. In addition, the connecting can be completed either during the manufacturing process or by the end user.

10

15

The terms "disposed on," "disposed along," "disposed with," or "disposed toward" and variations thereof are intended to mean that one element can be integral with another element, or that one element can be a separate structure bonded to or placed with or placed near another element.

20

"Layer" when used in the singular can have the dual meaning of a single element or a plurality of elements.

25

"Spunbonded fibers" refers to small diameter fibers which are formed by extruding molten thermoplastic material as filaments from a plurality of fine, usually circular capillaries of a spinneret with the diameter of the extruded filaments then being rapidly reduced to fibers as by, for example, in U.S. Patent No. 4,340,563 to Appel et al., and U.S. Patent No. 3,692,618 to Dorschner et al. , U.S. Patent No. 3,802,817 to Matsuki et al., U.S. Patent Nos. 3,338,992 and 3,341,394 to Kinney, U.S. Patent No. 3,502,763 to Hartman, and U.S. Patent No. 3,542,615 to Dobo et al., the contents of which are incorporated herein by reference in their entirety.

30

Spunbond fibers are generally continuous and have diameters generally greater than about 7 microns, more particularly, between about 10 and about 20 microns.

“Stretch bonded laminate” refers to a composite material having at least two layers in which one layer is a gatherable layer and the other layer is an elastic layer. The layers are joined together when the elastic layer is extended from its original condition so that upon relaxing the layers, the gatherable layer is gathered. Such a multilayer composite elastic material may be stretched to the extent that the non-elastic material gathered between the bond locations allows the elastic material to elongate. One type of stretch bonded laminate is disclosed, for example, by U.S. Patent No. 4,720, 415 to Vander Wielen et al., the content of which is incorporated herein by reference in its entirety. Other composite elastic materials are disclosed in U.S. Patent No. 4,789,699 to Kieffer et al., U.S. Patent No. 4, 781,966 to Taylor and U.S. Patent Nos. 4,657,802 and 4,652,487 to Morman and 4,655,760 to Morman et al., the contents of which are incorporated herein by reference in their entirety.

“Necking” or “neck stretching” interchangeably refer to a method of elongating a nonwoven fabric, generally in the machine direction, to reduce its width (cross-machine direction) in a controlled manner to a desired amount. The controlled stretching may take place under cool, room temperature or greater temperatures and is limited to an increase in overall dimension in the direction being stretched up to the elongation required to break the fabric, which in most cases is about 1.2 to 1.6 times. When relaxed, the web retracts toward, but does not return to, its original dimensions. Such a process is disclosed, for example, in U.S. Patent No. 4,443,513 to Meitner and Notheis, U.S. Patent Nos. 4,965,122, 4,981,747 and 5,114,781 to Morman and U.S. Patent No. 5,244,482 to Hassenboehier Jr. et al., the contents of which are incorporated herein by reference in their entirety.

“Ultrasonic bonding” refers to a process in which materials (fibers, webs, films, etc.) are joined by passing the materials between a sonic horn and anvil roll. An example of such a process is illustrated in U.S. Patent No. 4,374,888 to Bornslaeger, the content of which is incorporated herein by reference in its entirety.

“Thermal point bonding” involves passing materials (fibers, webs, films, etc.) to be bonded between a heated calender roll and an anvil roll. The calender roll is usually, though not always, patterned in some way so that the entire fabric is not bonded across its entire surface, and the anvil roll is usually flat. As a result, various patterns for calender rolls have been developed for functional as well as aesthetic reasons. Typically, the percent bonding area varies from around 10 percent to around 30 percent of the area of the fabric laminate. As is well known in the art, thermal point bonding holds the laminate layers together and imparts integrity to each individual layer by bonding filaments and/or fibers within each layer.

“Elastic” refers to any material, including a film, fiber, nonwoven web, or combination thereof, which upon application of a biasing force in at least one direction, is stretchable to a stretched, biased length which is at least about 110 percent, suitably at least about 130 percent, and particularly at least about 150 percent, its relaxed, unstretched length, and which will recover at least 15 percent of its elongation upon release of the stretching, biasing force. In the present application, a material need only possess these properties in at least one direction to be defined as elastic.

“Recover” or “recovery” refers to a contraction of a stretched material upon termination of a biasing force following stretching of the material by application of the biasing force. For example, if a material having a relaxed, unbiased length of one (1) inch is elongated 50 percent by stretching to a length of one and one half (1.5) inches the material would have a stretched length that is 150 percent of its relaxed length. If this exemplary stretched material contracted, that is recovered to a length of one and one tenth (1.1) inches after release of the biasing and stretching force, the material would have recovered 80 percent (0.4 inch) of its elongation.

“Polymer” generally includes but is not limited to, homopolymers, copolymers, such as for example, block, graft, random and alternating copolymers, terpolymers, etc. and blends and modifications thereof. Furthermore, unless otherwise specifically

limited, the term "polymer" shall include all possible geometrical configurations of the molecule. These configurations include, but are not limited to isotactic, syndiotactic and random symmetries.

- 5 These terms may be defined with additional language in the remaining portions of the specification.

Reference will now be made in detail to embodiments of the invention, one or more examples of which are illustrated in the drawings. Each example is provided by way of explanation of the invention, and not meant as a limitation of the invention. For example, features illustrated or described as part of one embodiment can be used with another embodiment to yield still a third embodiment. It is intended that the present invention include these and other modifications and variations.

15

The present invention is a respirator 10 that is generally constructed from a filter body 12 and one or more stretch-panels 14, exemplified by panels 14A and 14B in FIGS. 1-10. As shown, respirator 10 preferably has the general shape of a cup defining an opening 11 that is generally against the wearer's face when worn (see, FIG. 3). The filter body portion of the mask 10 is preferably held away from the wearer's nostrils and mouth. Such "off-the-face" style masks provide a breathing chamber to permit cooler wear and easier breathing.

The respirator is intended to be disposable, that is, used for a limited period of time and disposed of rather than washed or otherwise rejuvenated for reuse. The stretch-panel(s) 14 may be located at various locations of the respirator providing that it coincides with the mask periphery 16. Thus, a stretch-panel 14 at the mask periphery 16 may desirably stretch in a direction that is approximately tangent or parallel to the periphery 16 so that the periphery 16 can selectively increase in size as needed. More detailed non-limiting examples of the present invention are described below.

30

A first exemplary embodiment of the respirator 10, shown in FIGS. 1-5, may be constructed from a unitary filter body 12 and a single stretch-panel 14, specifically referred to as panel 14A. Desirably, filter body 12 is formed from one of more layers of material as described below. The filter body may be cut into a blank that is symmetric about a fold line 18. A fold is formed at fold line 18 when the constructed mask 10 is in a flat configuration (see FIGS. 1 and 2). Instead of the unitary body blank shown in FIG. 2, it is contemplated that two or more separate parts may form the filter body 12.

Referring now to FIG. 2, the overall shape of filter body 12 is defined by a top edge 22 flanked by a pair of side edges 24, which together extend across the nose bridge and along the cheeks of the wearer; a pair of bottom edges 25 that when joined together, extend along the lower jaw of a wearer (see FIG. 4); and a pair of seam edges 26 that converge together from the inner end of each bottom edge 25 to the lower end of the fold line 18. Each edge 22, 24, 25 and/or 26 may be curved as shown, or a may have an angular configuration. It is desirable to have the some type of headband attachment structure located near each junction of edges 22 and 24, referenced as points "A" and "B" in FIG. 2. For instance, side edge 24 may be shaped to define tab members 27, used to accommodate a headband attachment structure as described below.

Respirator 10 has an outer surface area (viewable when the mask is worn), and an opposite inner surface area. The outer surface area of the respirator 10 is defined as the sum of the filter body 12 outer surface area and the stretch-panel 14A outer surface area, minus any margins used to connect these components together. For embodiments having more than one stretch-panel, the outer surface of stretch-panel 14 is the sum of the individual outer surface areas for each stretch-panel.

Independent of any particular embodiment of respirator 10, the type of filter materials and/or media used may depend on the intended end use of the respirator by a consumer. For instance, different uses will require different levels of filtration, which is beyond the scope of the present invention. Desirably, the combined

layers of the filter body provide structural stiffness such that mask 10 does not collapse against the nose and mouth while being worn.

5 As noted, suitable materials for the filter body 12 may include one or more layers of material. In one embodiment, there are two layers of material. Outer layer 60 may be formed from a material that is (a) gas permeable such that it permits air to pass through filter body 12 in both directions, and (b) liquid impermeable such that it prevents liquid from passing through layer 60 in at least one direction. Layer 60 is preferably arranged to help prevent the passage of liquids from the exterior of  
10 mask 10 to the interior of mask 10.

In another embodiment, filter body 12 is a three layer structure that includes an outer mask layer 60, an inner mask layer 62, and a middle layer (not shown). In one particular embodiment, filter body 12 may include outer mask layer 60 that is  
15 constructed from a spun-bonded polypropylene that may have a 30.5 gsm basis weight. Alternative materials for outer mask layer 60 include, but are not limited to, thermally-formed polyester-bonded carded web, bi-component and/or powder bonded polyethylene or polypropylene nonwovens, wet-laid nonwovens, cellulosic tissue, or a spunbond polyester. The basis weight of these materials may range  
20 from about 15 to about 200 gsm.

Inner mask layer 62 may be constructed from the same materials as layer 60, or a in the alternative, a composite made from bicomponent polyethylene and polypropylene, or a composite made from bicomponent polyethylene and  
25 polyester. Layer 62 may also be constructed from a polyester and/or polyethylene material or a cellulosic tissue. In one particular embodiment, layer 62 is a thermally formed blended fiber bonded carded web. Desirably, layer 62 may have a basis weight of about 17 gsm.

30 Selection of the number and type of the middle layers of filter media, which may be disposed between outer mask layer 60 and inner mask layer 62, can depend on the degree and type of filtration required by the wearer. Suitable mediums for the middle layer include, but are not limited to, melt-blown polypropylene, extruded

polycarbonate, melt-blown polyester, or melt-blown urethane, bicomponent spunbond and/or an expanded polytetrafluoroethylene (PTFE) membrane. In one particular embodiment, the middle layer may be a filtrating material such as electret-treated meltblown polypropylene having a basis weight of roughly 70 gsm, or alternatively, in the range of about 30 to about 120 gsm. Further, the middle layer may be a combination of lighter weight layers which together, add up to the desired basis weight. In one non-limiting example, the middle layer may be a laminate formed from a two plies of 50 gsm sheets.

Stretch-panel 14A may have various shapes. For example, as seen in FIG. 2, stretch-panel 14A is basically a triangular wedge. It is contemplated that stretch-panel 14A may be asymmetric or symmetric as shown. Further, stretch-panel 14A may be a truncated ovoid, a rectangle, or even a decorative shape such as a lightning bolt. If there is more than one stretch-panel (as seen in latter embodiments of the present invention) they do not need to be identical shapes. Regardless of the exact shape of any stretch-panel 14, it will characteristically have an edge, such as edge 28, coincides with the periphery 16. Because the stretch-panel is designed to stretch, the shape desirably provides adequate area adjacent the edge 28, and an adequate length for edge 28, so as not to prevent or limit stretching.

In the specific embodiment of FIG. 2, stretch-panel 14 is symmetric in shape and has a pair of sides 25' which correspond in length to the bottom edges 25 on filter body 12. Desirably, the length of side 25 is about equal to the length of side 25'.

Most desirably, the triangular shape is truncated to create a short side 29. The purpose of truncation is to lessen the amount of material that comes together when seam 26 is created, specifically, at the outer end 30 of seam edges 26. This reduction of material will create a cleaner and more flexible seam.

Regardless of the stretch-panel location, stretch-panel 14 is desirably constructed from a material that is stretchable in at least one direction, and air impermeable. The term "stretchable" describes a material that can stretch yet substantially recover to its initial pre-stretched dimension. The term "air impermeable" means

that for all practical purposes, the wearer cannot breathe through the stretch-panel 14. One direction of stretch will substantially align with the periphery edge 16. If periphery edge 16 is a straight edge, it is desirable that the stretch direction be about parallel with periphery 16. If periphery 16 is a curved edge, it is desirable  
5 that the stretch direction be about parallel with a tangent of periphery 16 taken at about the midpoint of a stretch-panel edge 28.

Suitable materials for the stretch-panel 14 include, but are not limited to, films, nonwovens, or laminates that may include an elastic component such as natural  
10 rubber latex, urethanes, elastic block copolymers (e.g. KRATON<sup>®</sup> from Kraton Polymers LLC or VISTAMAXX<sup>™</sup> from ExxonMobil Chemical Co.). Laminates may be in the form of necked materials such as necked bonded nonwovens, or single- or dual-faced elastic film laminates such as stretch bonded laminates. Desirably, these stretch-panel 14 materials can be stretched to at least about 30% of an  
15 original length. However, it may be more desirable that such materials may be stretchable up to about 100% of an original length, and most desirable that such materials may be stretchable up to about 200% of an original length. The stretch-panel material may be air impermeable, or have a greater filtration performance (e.g. higher density, less porous, etc.) throughout the entire range of stretch than  
20 filter body 12.

Referring to FIG. 1, inside of top edge 22 of the mask 10, there may be an elongated malleable strip 52 as shown in FIGS. 1-3 and 5. Malleable strip 52, known in the respirator art, is provided so that top edge 22 of mask 10 can be  
25 configured to closely fit the contours of the nose of the wearer. In order to reduce "blow-by" associated with normal breathing of the wearer, malleable strip 52 is preferably positioned at about the center of top edge 22 and has a length in the range of about 40 percent to about 70 percent of the total length of the top edge 22, defined as the distance between points A and B (see FIG. 2). Malleable  
30 member 52 is preferably constructed from an aluminum-alloy strip with a rectangular cross-section, but may also be a moldable or malleable metal or plastic member. Desirably, strip 52 is located between layers 60, 62, and may be held in position by adhesive, or by a border that is stitched or heat sealed to closely

surround strip 52 to prevent slippage. Malleable strip 52 may be used in any embodiment of the present invention.

5 The present invention may further include devices for attaching mask 10 to the face of the wearer. Any type of conventional attachment devices are within the scope and spirit of the invention. For example, the mask 10 may include at least one strap for securing about the wearer's head. Alternatively, the mask may include straps extending from the top and bottom edges thereof for being tied around the wearer's head (not shown). In an alternative embodiment, the mask  
10 may include loops for being fitted over the ears of a wearer (not shown). A vast number of attaching devices are well known to those skilled in the art and any manner of such device may be incorporated in the present invention. It should be appreciated that a number of configurations and alternative embodiments may be employed in the present invention, and that the invention is not limited to any  
15 particular type of attachment method to the face of the wearer. It is most desirable that the attaching device allows a wearer to place the respirator 10 onto the wearer in a manner that no gapping between the wearer's face and the periphery 16 occurs accidentally.

20 In one exemplary embodiment of the present invention, a simple headband attachment device is a strap 42, and one of the ways to adjustably connect the headband strap 42 to a respirator 10 is through an aperture such as a slit 44. However, it is contemplated that additional clips, snaps, loops, hook and loop, buttons, or other mechanical fasteners may be used to selectively and/or  
25 adjustably attach a headband straps 42 to respirator 10. For some applications, headband straps 42 are preferably constructed from resilient polyurethane, but may be constructed from elastic rubber or a covered stretch yarn. The covered stretch yarn may consist of an elastomeric material wrapped with nylon or polyester. For other applications, headband straps 42 may be double knitted  
30 headbands such as circle knitted polyester/LYCRA or nylon/LYCRA. Any flexible strip that is tolerated by the wearer may be used as a strap.

The assembly of mask 10 is as follows. Filter body 12 may be formed by cutting and connecting layers 60, 62 and optional middle layer (or other layers) to each other along margins adjacent the periphery 16. Such connections are preferably provided along top edge 22 and side edges 24, respectively. Referring to FIG. 1, the corresponding margins 65 may be formed by sewing, glue, heat sealing, welding, thermal point bonding, ultrasonic bonding and/or any other suitable connection procedure. In addition, a margin 67 may surround slit 33 for structural reinforcement. After the margins are formed on the filter body, the body-facing surface of the mask may be brought together by folding the blank about fold line 18.

The stretch-panel edges 25' are aligned with the filter body edges 25 and bonded together to form outwardly facing fin seams 71. The edges 26 may be further be bonded together in a like manner to create an outwardly facing fin seam 73. The junction between seams 71 and 73 is bonded to prevent air leakage. Top edge 22, side edge 24, and exposed edge 28 of the stretch-panel 14A cooperate with each other to define the periphery 16 at the opening 11 of mask 10.

Desirably, each of the bonded seams 71, 73 share the characteristic of being air impermeable. Though it is contemplated that lap seams or other connection methods may be used. It is most desirable that seams 71 and 73 be created via an air impermeable bond such as a pressure or ultrasonic bond.

A second exemplary embodiment of the respirator 10, shown in FIG. 6, has not one, but two stretch-panels 14, designated as "14B." Of course, more than two stretch-panels may make up the overall surface area of mask 10. However, if stretch-panel 14 is air impermeable, it may not be desirable to incorporate too much stretch-panel material into the mask configuration as the mask 10 breathability could be compromised.

The shape of filter body 12 differs from that shown in FIG. 2 in that it is larger. The filter body 12 is symmetric about the fold line 18. Because there is no stretch-panel 14A located under the chin, the seam edges 26 extend all the way to edges

24. Seam edges 26 extend between points "C" and "E." A fin seam 73 (or other seam type mentioned previously) formed by connecting the seam edges 26 together. Desirably, fin seam 73 is air impermeable as in the previous embodiment.

5

As described above, stretch-panels 14B may be triangular as shown, or the other various shapes mentioned. Desirably, each stretch-panel is located over the wearer's cheeks in a symmetric configuration. In the embodiment of FIG. 6, each stretch-panel 14B is located between the headband structure, tab 27 at about point "D" and the end of seam 26 at point "C." The stretch-panel 14B has an edge 28 that is shorter in length than the distance 80 between points "C" and "D."

10

Desirably, the length 82 of edge 28 is between about 0.2 to about 0.33 the length of distance 80. More desirably, length 82 is less than about 0.25 to about 0.5 of the length of distance 80.

15

Referring now to FIG. 8, the side panels 14B may be positioned to coincide with the tab member 27, and may have strap 42 or another headband attachment device connected thereto.

20

Referring to FIGS. 9 and 10, the panels 14B as shown in FIGS. 6 and 8 may be elongated and meet at the edge 26. It is further contemplated in these embodiments; the stretch-panels 14B may be clear or translucent so that one may be able to see the wearer's mouth.

25

Desirably, in the embodiments shown in FIGS. 6-10, like seams 71 of the first embodiment, seams 77 are outwardly facing fin seams created by an air impermeable bond such as a pressure or ultrasonic bond.

30

It is further contemplated that a direction of stretch may coincide with the anticipated movement of the wearer. For instance, chewing may cause the wearer's jaw to move in direction 84 (see FIG. 6). Thus, the stretch direction of panel 14B may substantially align with direction 84. So as not to "lock up" the

stretchability of panel 14B, the periphery may also be configured to align with the anticipated direction of movement.

The embodiment of respirator 10 as shown in FIG. 7 differs from the previous  
5 embodiment in that an exhalation attachment device 100 replaces the slit 44 and strap 42 (described in the embodiment of FIG. 1). This device 100 bypasses the filtration media of the respirator during exhalation enabling faster expulsion of the hot humid exhaled breath. This improves the comfort of the respirator. Generally, vent 100 is defined by a vent body having a fastening system attached thereto.

10 The fastening system comprises at least one pull-strap fastening component 102 being formed integrally with a fastening component 104. Additional details regarding the vent 100 are disclosed in U.S. Patent Application, Serial 11/840031, filed August 16, 2007, and incorporated herein to the extent it is consistent with the present invention. Other applicable exhalation vents are shown and described in  
15 U.S. Patent Application, Serial 11/840046, filed August 16, 2007, and incorporated herein to the extent it is consistent with the present invention.

Although only a few exemplary embodiments of this invention have been described in detail above, those skilled in the art will readily appreciate that many  
20 modifications are possible in the exemplary embodiments without materially departing from the novel teachings and advantages of this invention. The mask may be configured as any number of conventional masks. For example, the mask may be formed as a traditional molded cup or cone-shaped mask. Various configurations and shapes of masks are well known to those skilled in the art and  
25 any and all such conventional masks are within the scope and spirit of the present invention.

**CLAIMS**

1. A disposable respirator which defines an area surrounded by a periphery, the disposable respirator extending across a wearer's nose bridge, across  
5 each of the wearer's cheeks, and underneath the wearer's chin for covering the nose and mouth of the wearer, the disposable respirator comprising:

a filter body comprising a non-elastic material defining a body outer surface area; and

10 a first stretch-panel comprising an elastic material and having an outer edge defining a portion of the mask periphery, the first stretch-panel defining a panel outer surface area,

15 wherein the panel outer surface area is less than the filter outer surface area.

2. The disposable respirator of claim 1 wherein the first stretch-panel comprises a stretch direction that is about parallel with the outer edge of the  
20 first stretch-panel.

3. The disposable respirator of claim 1 wherein the first stretch-panel is substantially triangular in shape.

25 4. The disposable respirator of claim 1 wherein the first stretch-panel is air impermeable.

5. The disposable respirator of claim 1 further comprising a second stretch-panel, wherein the first stretch-panel and the second stretch-panel are  
30 attached to the filter body, and wherein the panel outer surface area is defined by the outer surface area of the first stretch-panel and the outer surface area of the second stretch-panel.

6. The disposable respirator of claim 5 wherein the first and the second stretch-panels are substantially triangular in shape.
7. The disposable respirator of claim 5 wherein the first and the second stretch-panels comprise four-sided polygons.
8. The disposable respirator of claim 5 wherein the first stretch-panel and the second stretch-panel are spaced apart and arranged to fit over each of the wearer's cheeks.
9. The disposable respirator of claim 5 wherein the first stretch-panel and the second stretch-panel are connected together.
10. The disposable respirator of claim 1 wherein the first stretch-panel comprises a fold line such that when the respirator is in a flat configuration, the stretch-panel is folded inward toward a body-facing surface of the respirator.
11. The disposable respirator of claim 1 wherein the first stretch-panel is symmetrically disposed on the mask with respect to the fold line.
12. The disposable respirator of claim 1 wherein the first stretch-panel comprises an elastic film.
13. The disposable respirator of claim 12 wherein the first stretch-panel comprises a stretch bonded laminate.
14. A disposable respirator for a wearer, the respirator comprising:  
a filter body sized to fit over the mouth and nose of the wearer, the filter body having a top edge arranged to extend across the nose and cheeks of the wearer, a bottom edge arranged to extend along a wearer's jaw line, and a seam edge arranged to extend between the wearer's nose to the wearer's chin; and

a triangular stretch-panel attached to the bottom edge of the filter body, wherein the stretch-panel is arranged to fit underneath the wearer's chin.

15. A disposable respirator for a wearer, the respirator comprising:

5 a filter body sized to fit over the mouth and nose of the wearer, the filter body having a top edge arranged to extend across a nose and upper cheeks of the wearer, and a bottom edge arranged to extend along lower cheeks and underneath a chin of the wearer, wherein the bottom edge has two spaced apart notched portions; and a seam edge arranged to extend  
10 between the wearer's nose to the wearer's chin; and  
a stretch-panel disposed within each of the of notched portions and attached to the filter body.

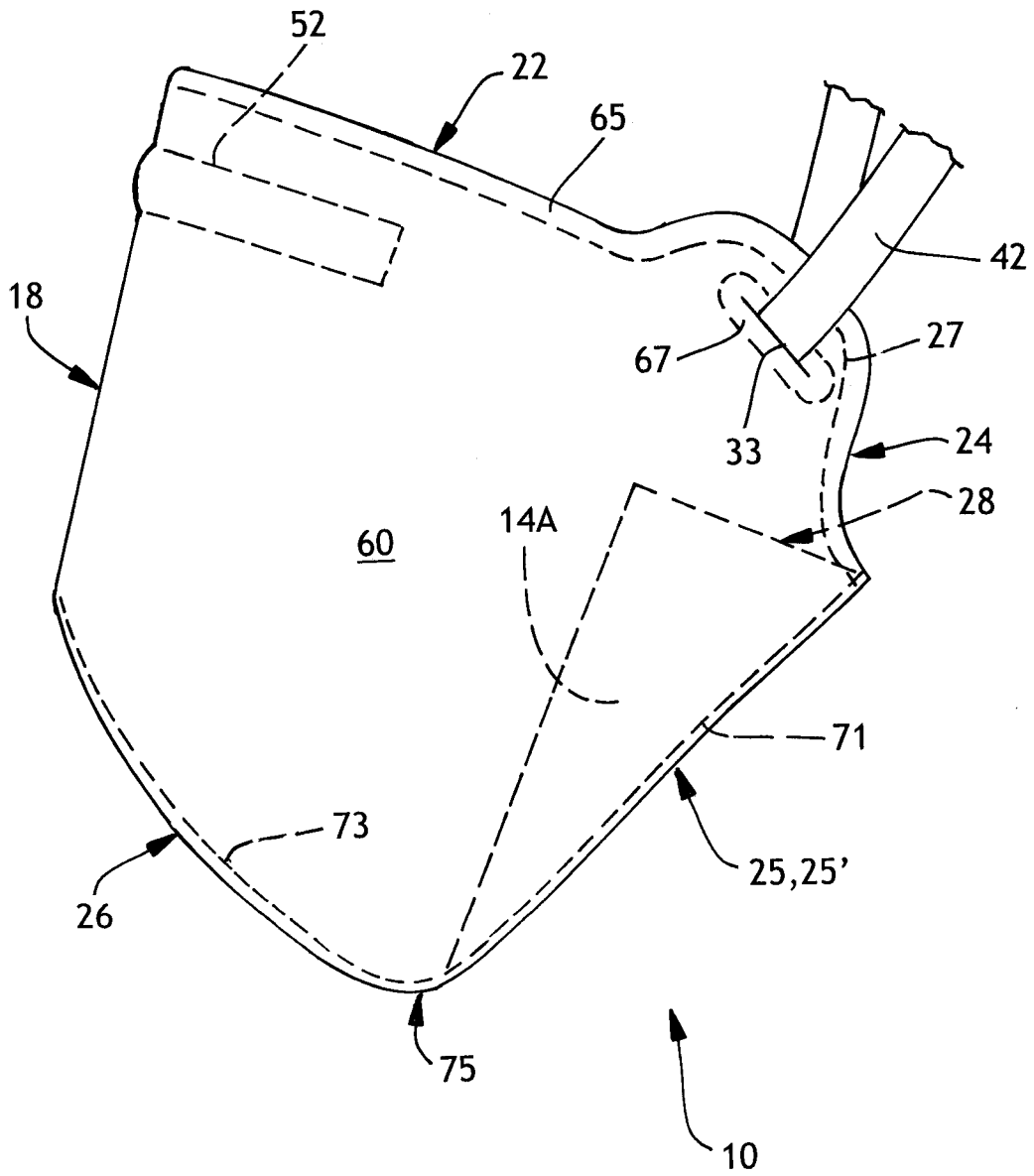
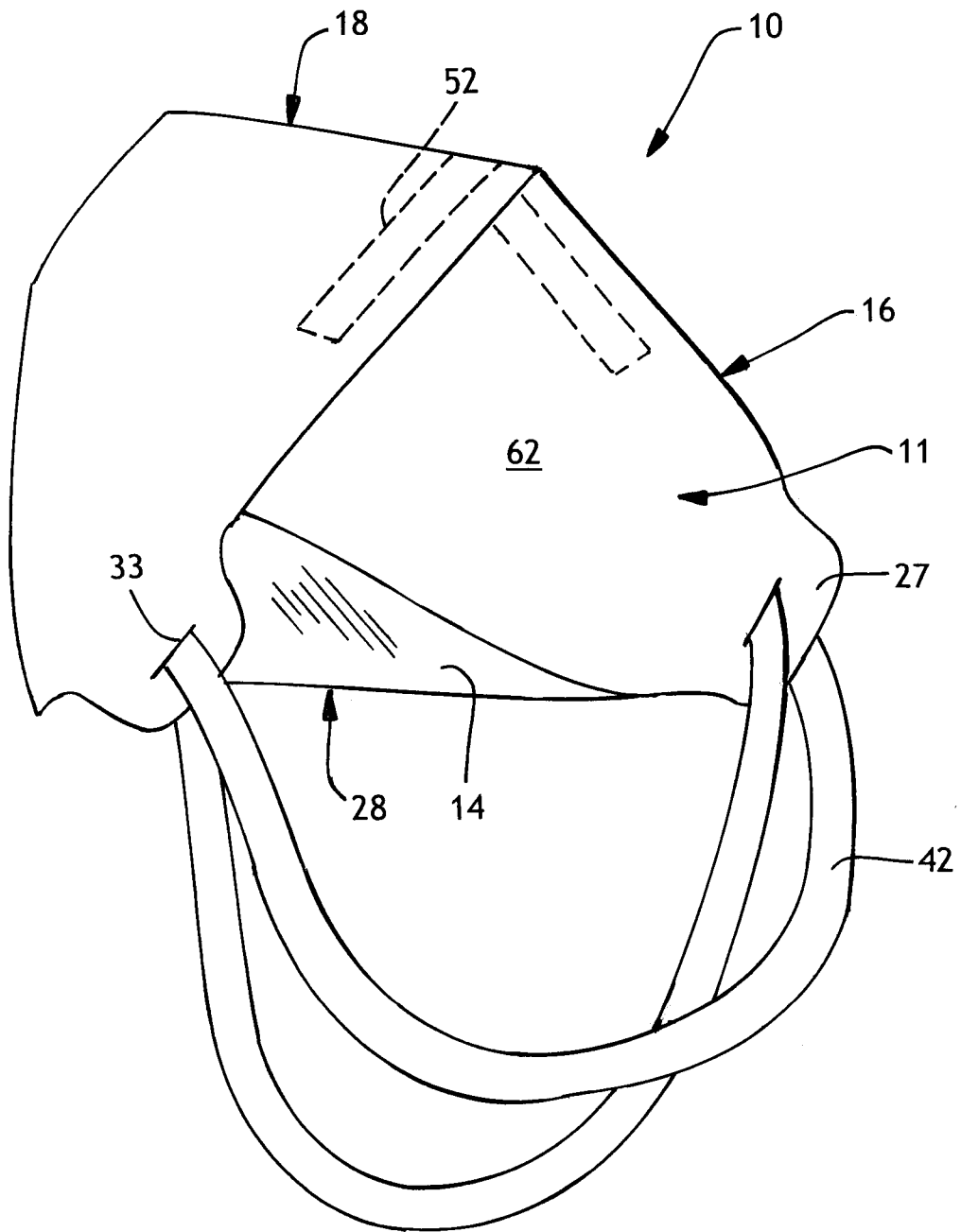

FIG. 1



**3/10**



**FIG. 3**

# 4/10

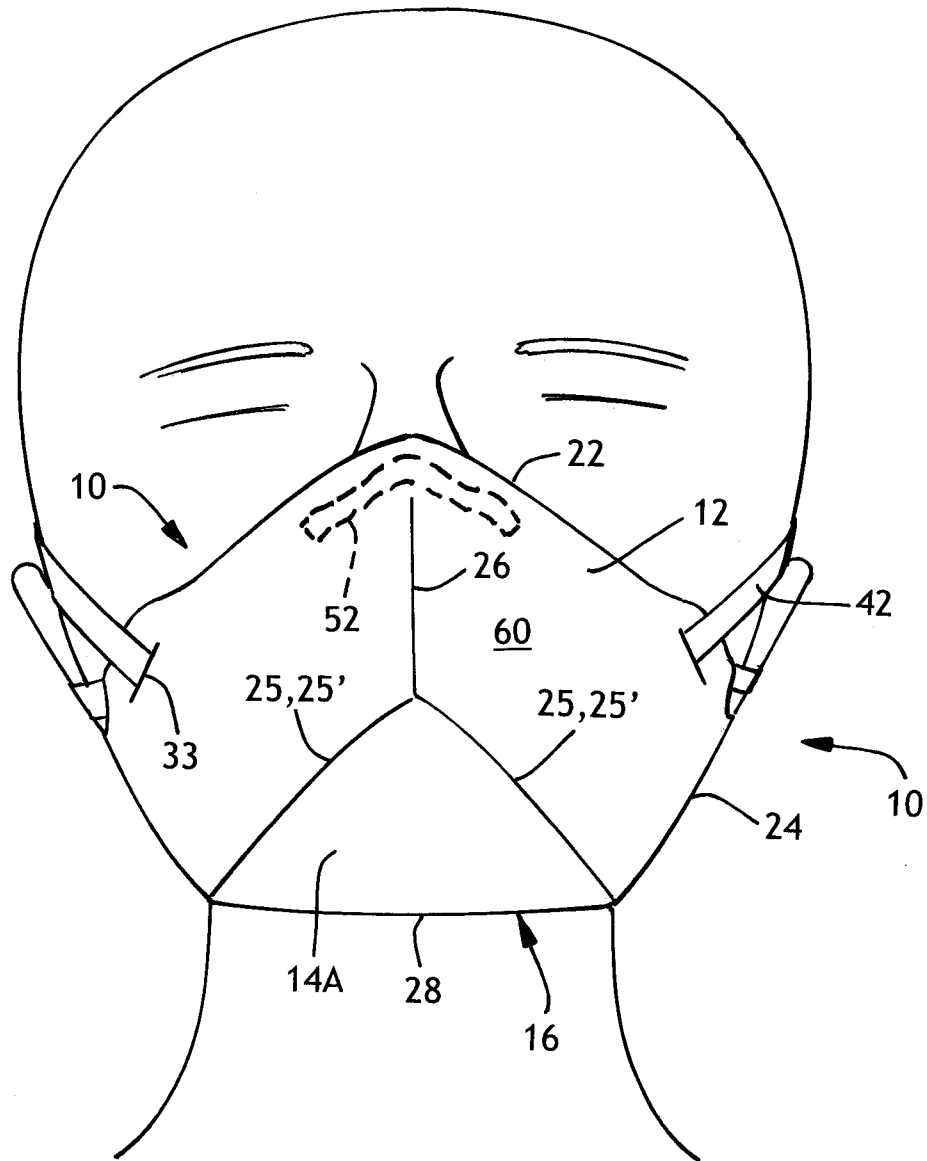

FIG. 4

# 5/10

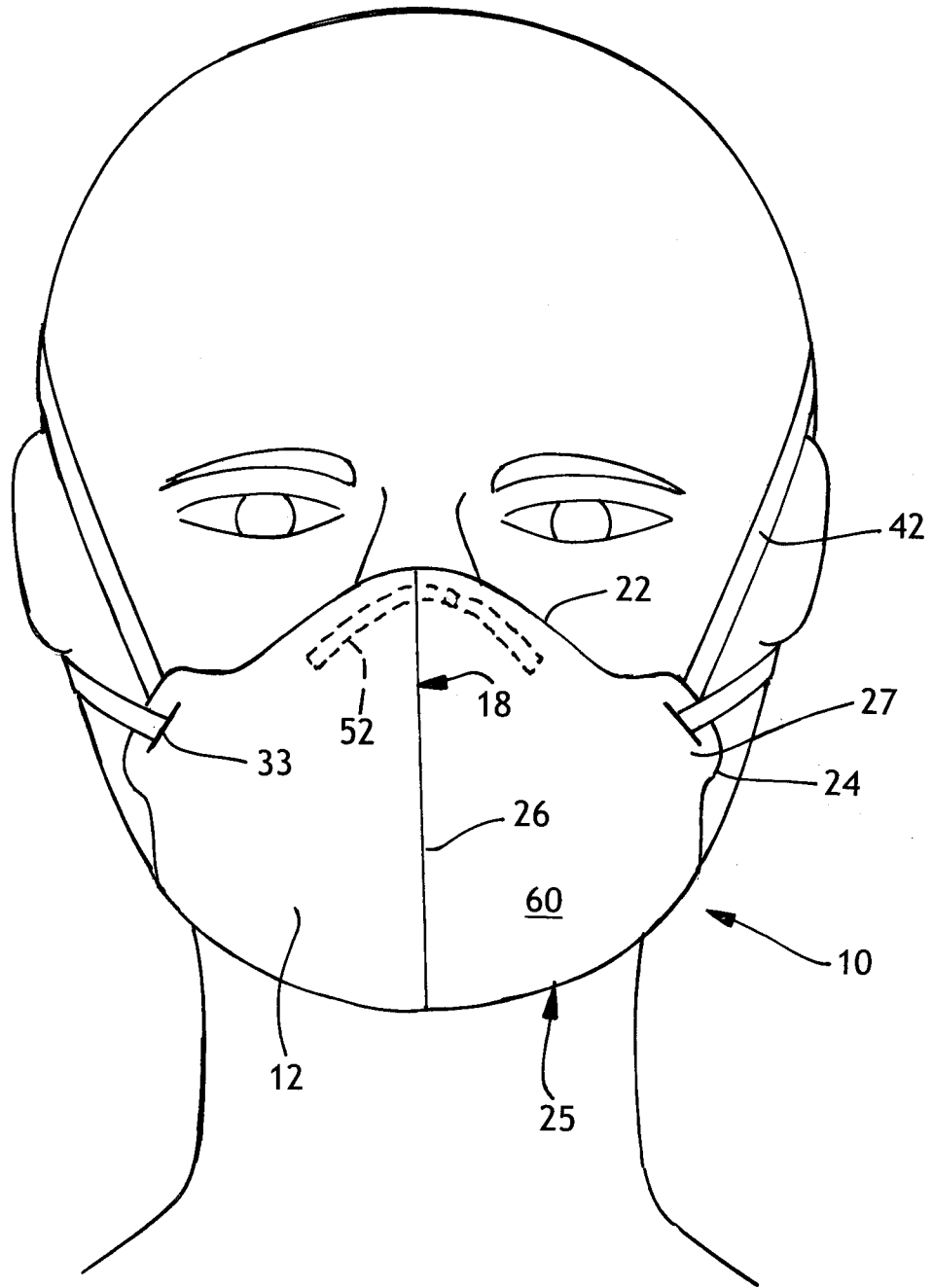

FIG. 5

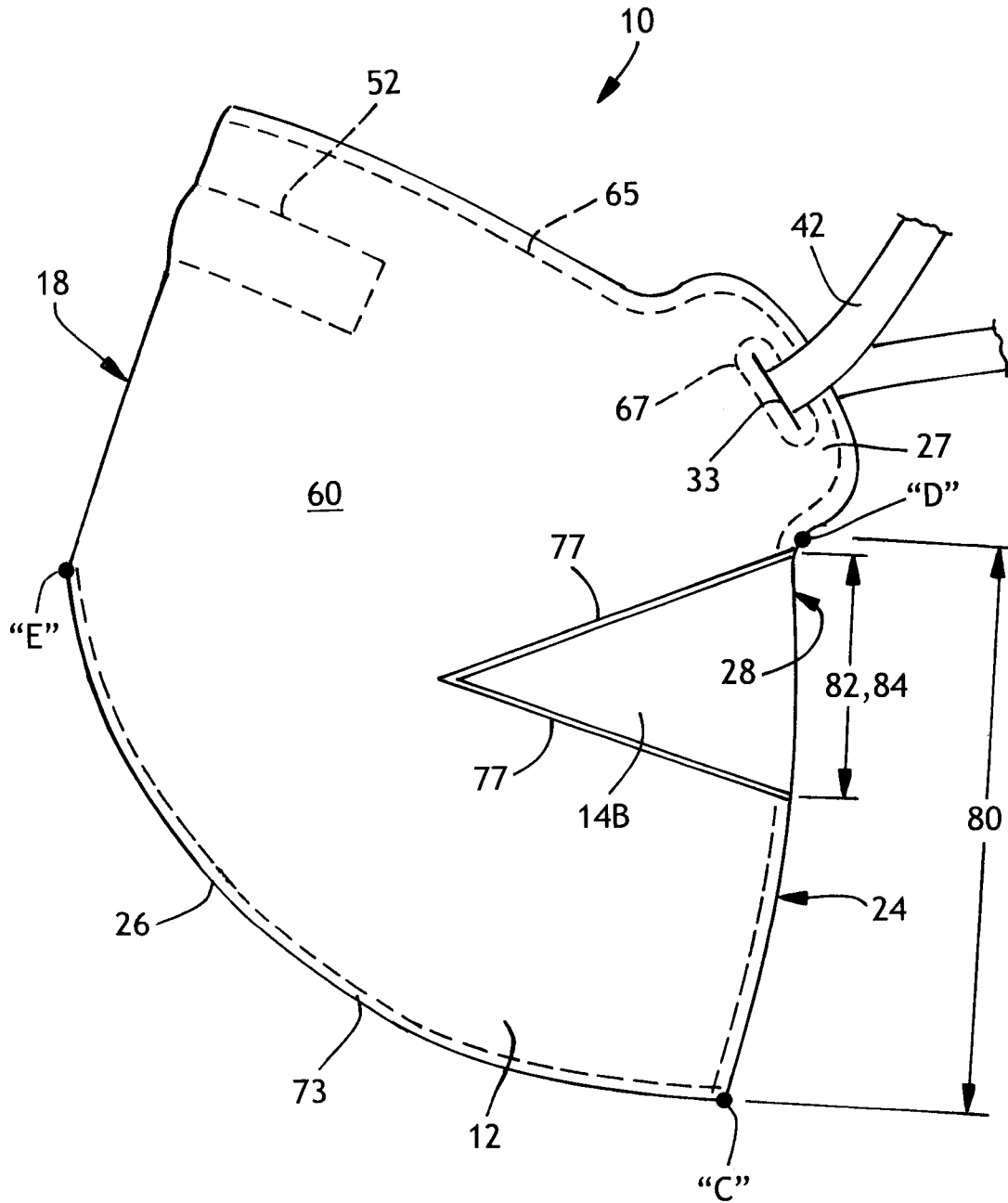
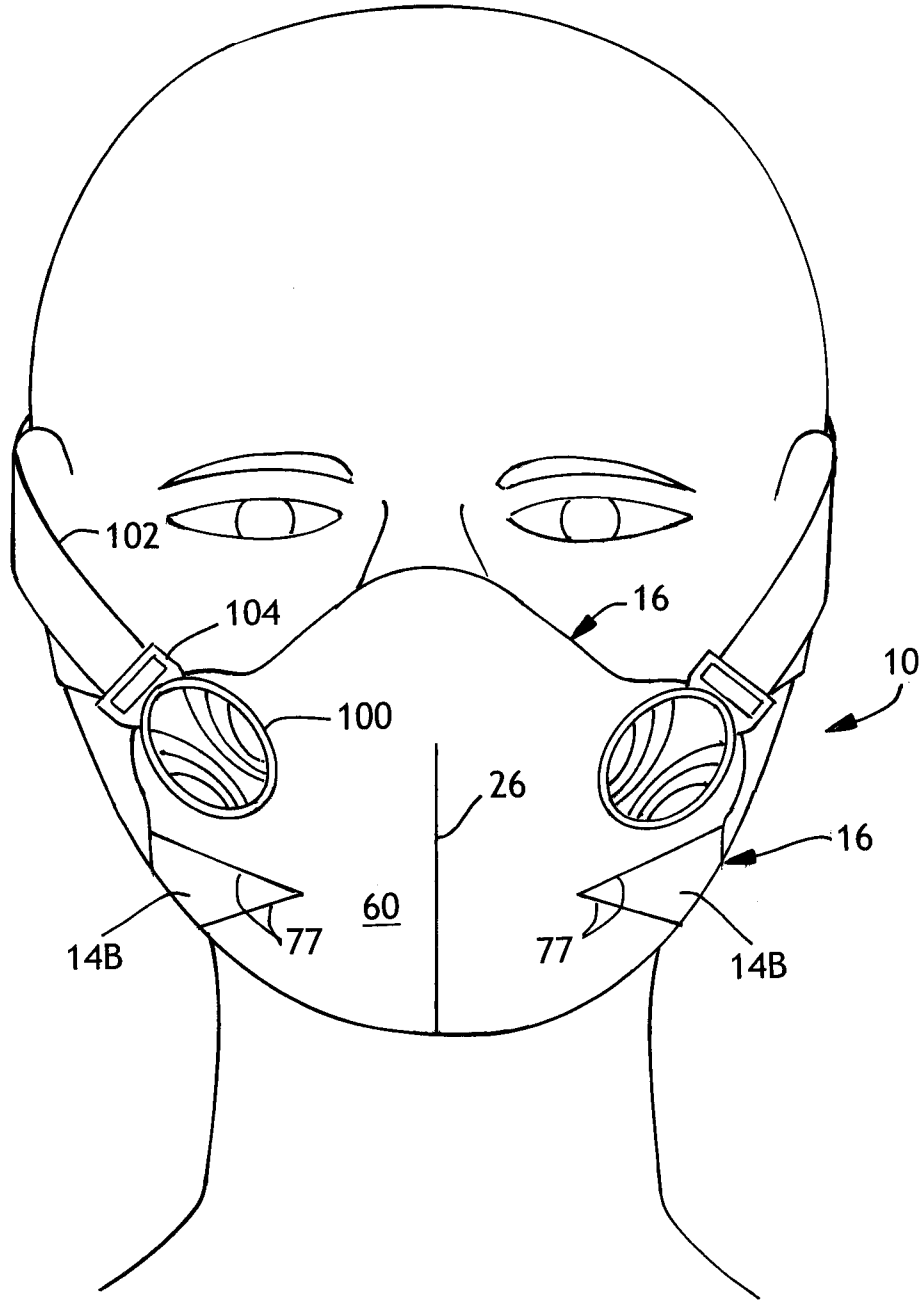

FIG. 6

**7/10**



**FIG. 7**

# 8/10

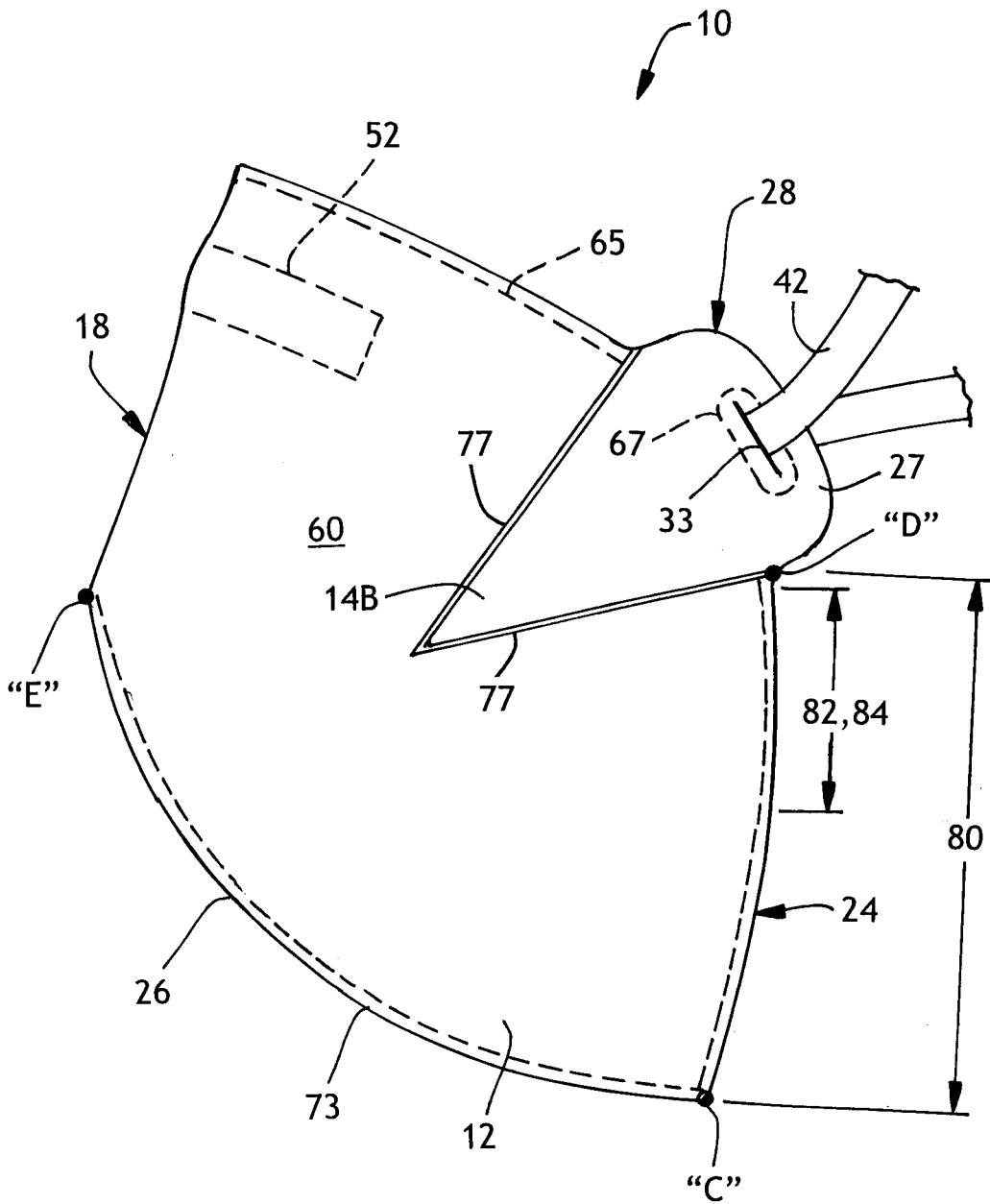

FIG. 8

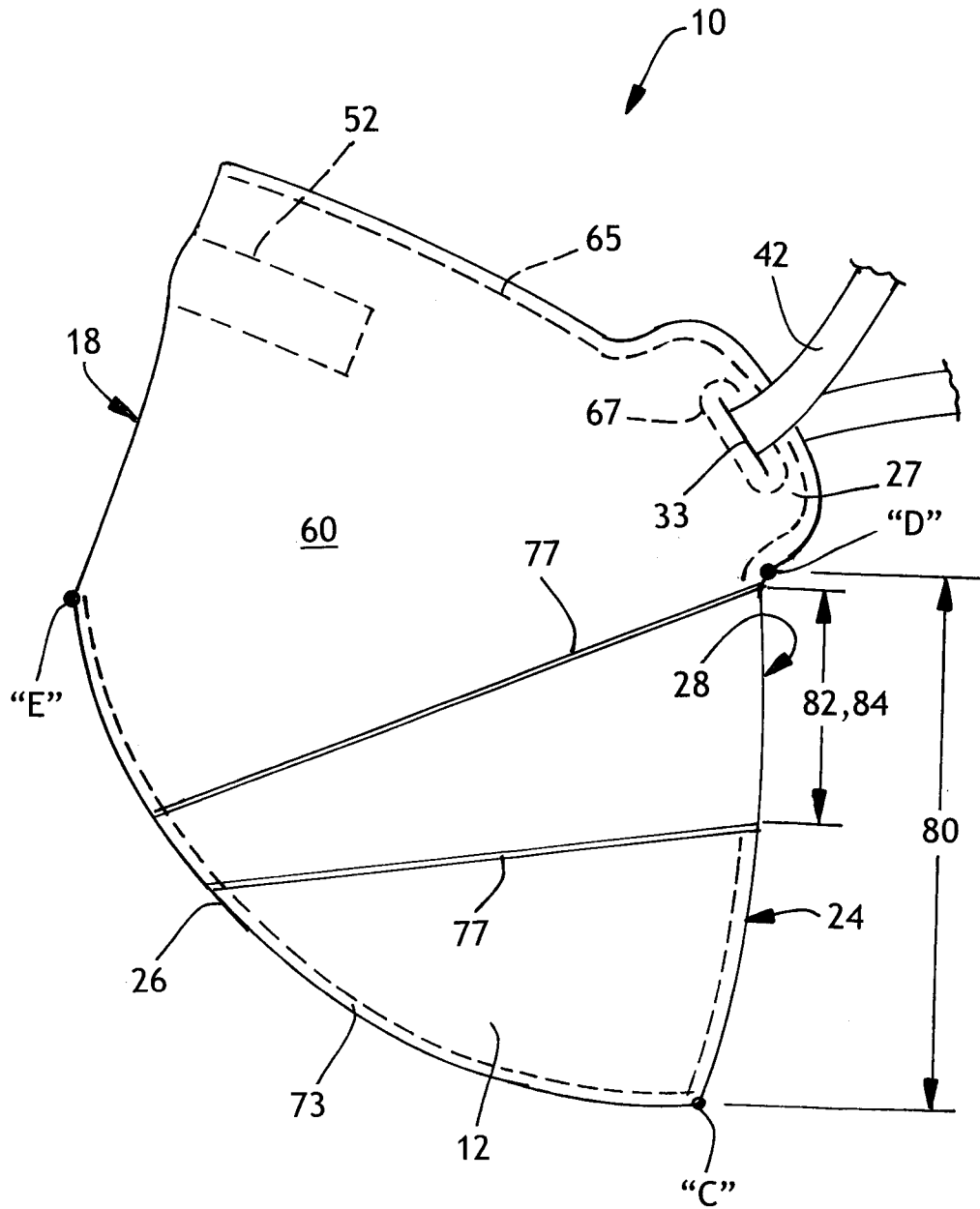

FIG. 9

# 10/10

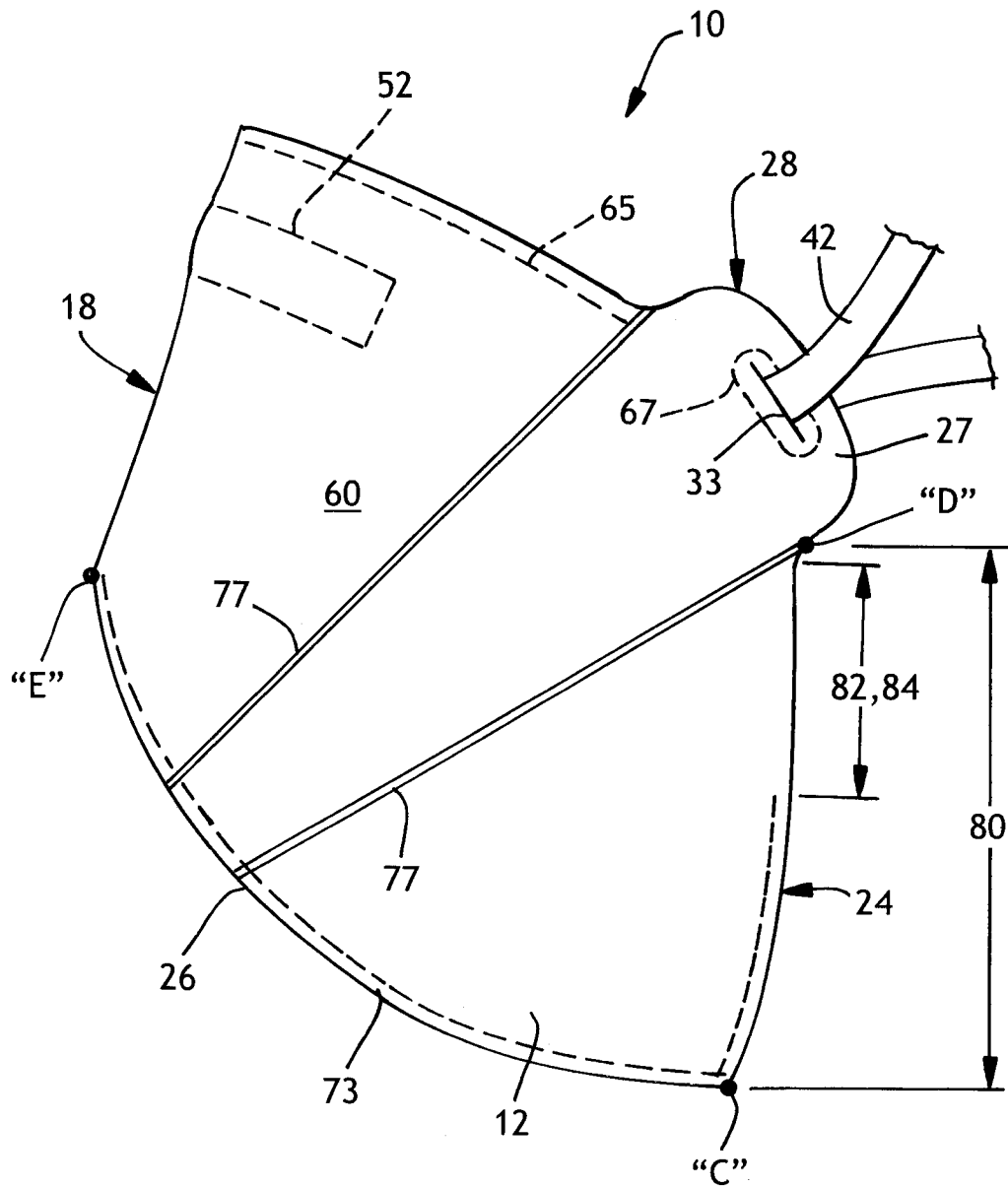

FIG. 10