



- (51) International Patent Classification:
A61B 17/86 (2006.01) A61B 17/88 (2006.01)
A61B 17/80 (2006.01)
- (21) International Application Number:
PCT/US2014/043569
- (22) International Filing Date:
23 June 2014 (23.06.2014)
- (25) Filing Language: English
- (26) Publication Language: English
- (30) Priority Data:
61/839,176 25 June 2013 (25.06.2013) US
14/304,534 13 June 2014 (13.06.2014) US
- (71) Applicant: GLOBUS MEDICAL, INC. [US/US]; Valley Forge Business Center, 2560 General Armistead Avenue, Audubon, Pennsylvania 19403 (US).
- (72) Inventors: LAWSON, Stephan; 15 Glencoe Road, Upper Darby, Pennsylvania 19082 (US). CIANFRANI, Jason; 110 Teakwood Court, East Norriton, Pennsylvania 19401

(US). SUH, Sean; 777 West Germantown Pike, #1013, Plymouth Meeting, Pennsylvania 19702 (US). SUH, Jon; 28 Highgate Lane, Blue Bell, Pennsylvania 19422 (US). BLACK, Michael; 711 Milmont Avenue, Swarthmore, Pennsylvania 19081 (US). ANGELUCCI, Chris; 809 Summit Avenue, Schwenksville, Pennsylvania 19473 (US). HANSELT, Matt; 148 Colorado Court, Schwenksville, Pennsylvania 19473 (US).

(74) Agent: CASTELLANO, Kristina; Castellano PLLC, P.O. Box 1555, Great Falls, Virginia 22066 (US).

(81) Designated States (unless otherwise indicated, for every kind of national protection available): AE, AG, AL, AM, AO, AT, AU, AZ, BA, BB, BG, BH, BN, BR, BW, BY, BZ, CA, CH, CL, CN, CO, CR, CU, CZ, DE, DK, DM, DO, DZ, EC, EE, EG, ES, FI, GB, GD, GE, GH, GM, GT, HN, HR, HU, ID, IL, IN, IR, IS, JP, KE, KG, KN, KP, KR, KZ, LA, LC, LK, LR, LS, LT, LU, LY, MA, MD, ME, MG, MK, MN, MW, MX, MY, MZ, NA, NG, NI, NO, NZ, OM, PA, PE, PG, PH, PL, PT, QA, RO, RS, RU, RW, SA, SC, SD, SE, SG, SK, SL, SM, ST, SV, SY, TH, TJ, TM,

[Continued on next page]

(54) Title: ORTHOPEDIC ANCHOR ASSEMBLY

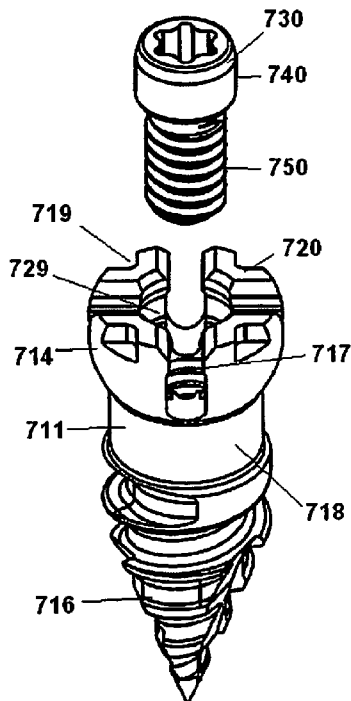

FIG. 13A

(57) Abstract: An orthopedic assembly is described that comprises an orthopedic device, an anchor, and a locking mechanism. The orthopedic device can be a plate member having an aperture that is configured to receive the anchor. The anchor can include a head, neck and shank portion. The head portion can include a plurality of arms separated by grooves that are capable of splaying. The assembly is configured such that when the locking mechanism is inserted into the head portion, this causes expansion of the arms of the head. This expansion locks and secures the anchor to the orthopedic device. Various instruments are provided that can deliver the locking mechanism to the anchor, and can provide impact to lock functionality.





TN, TR, TT, TZ, UA, UG, US, UZ, VC, VN, ZA, ZM, ZW.

EE, ES, FI, FR, GB, GR, HR, HU, IE, IS, IT, LT, LU, LV, MC, MK, MT, NL, NO, PL, PT, RO, RS, SE, SI, SK, SM, TR), OAPI (BF, BJ, CF, CG, CI, CM, GA, GN, GQ, GW, KM, ML, MR, NE, SN, TD, TG).

(84) Designated States (unless otherwise indicated, for every kind of regional protection available): ARIPO (BW, GH, GM, KE, LR, LS, MW, MZ, NA, RW, SD, SL, SZ, TZ, UG, ZM, ZW), Eurasian (AM, AZ, BY, KG, KZ, RU, TJ, TM), European (AL, AT, BE, BG, CH, CY, CZ, DE, DK,

Published:

— with international search report (Art. 21(3))

ORTHOPEDIC ANCHOR ASSEMBLY

CROSS REFERENCE TO RELATED APPLICATIONS

[001] The present application is a continuation-in-part application of pending U.S. Application 13/548,641, filed July 13, 2012, which is a continuation application of U.S. Application 12/371,437, filed February 13, 2009, now issued as U.S. 8,241,339. The present application is also a continuation-in-part application of pending U.S. Application 13/273,625, filed October 14, 2011. The present application also claims priority to U.S. Provisional Application U.S. 61/839,176, filed June 25, 2013. The entire contents of each of these references are herein incorporated by reference in their entireties.

FIELD OF THE INVENTION

[002] The present invention is directed to a bone fixation assembly and, in particular, to an anchor assembly for securing an orthopedic device to bone tissue.

BACKGROUND OF THE INVENTION

[003] In the field of orthopedic surgery, and more specifically spinal surgery, bone anchors may be used for fixation or for the fastening of orthopedic devices or instruments to bone tissue. An exemplary use of bone anchors may include using the bone anchors to fasten an orthopedic device, such as a bone plate, a spinal rod, or a spinal spacer, to a vertebral body for the treatment of a deformity or defect in a patient's spine. Focusing on the bone plate example, bone anchors can be secured to a number of vertebral bodies and a bone plate can then be connected to the vertebral bodies via the bone anchors to fuse a segment of the spine. In another example, bone anchors can be used to fix the location of a spinal spacer once the spacer is implanted between adjacent vertebral bodies. In yet another example, bone anchors can be fastened to a number of vertebral bodies to anchor a spinal rod in place along a spinal column to treat a spinal deformity.

[004] In each of these exemplary uses, a plurality of bone anchors are needed to fasten the orthopedic device to the area of treatment. In addition, depending on the extent of the disease or size of the defect to be treated, it is possible that several orthopedic devices each requiring a plurality of bone anchors may be required. Accordingly, the fastening of the orthopedic implants to the area of treatment can become a time consuming and even difficult task.

[005] As such, there exists a need for bone anchors that can quickly and securely fasten an orthopedic device to the area of treatment.

SUMMARY OF THE INVENTION

[006] Various embodiments of orthopedic assemblies are provided. In some embodiments, an orthopedic assembly comprises a plate member having an aperture. An anchor is insertable through the aperture of the plate member. The anchor can include a plurality of arms separated by grooves. The assembly further comprises a locking mechanism insertable through the anchor. The locking mechanism can include a plurality of fingers corresponding to each of the arms. Downward insertion of the locking mechanism through the anchor causes the plurality of arms to splay outwardly to thereby secure the anchor to the plate member.

[007] In some embodiments, an orthopedic assembly comprises a plate member having an aperture. An anchor is insertable through the aperture of the plate member. The anchor includes a plurality of arms, wherein each of the arms includes a slot formed in an inner wall. A locking mechanism is insertable through the anchor. The locking mechanism includes a plurality of fingers, wherein each finger is insertable into a slot of the anchor. Downward insertion of the locking mechanism through the anchor causes the plurality of arms to splay outwardly to thereby secure the anchor to the plate member.

[008] In some embodiments, an orthopedic assembly comprises a plate member having an aperture. An anchor is insertable through the aperture of the plate member. A locking mechanism is insertable through the anchor. The locking mechanism is capable of expanding the anchor to secure the anchor to the plate member. An insertion instrument is further provided to deliver the locking mechanism to the anchor via an impaction process.

BRIEF DESCRIPTION OF THE DRAWINGS

[009] The present invention will become more fully understood from the detailed description and the accompanying drawings, wherein:

[010] FIG. 1 is an exploded partial perspective view of one embodiment of an anchor assembly;

[011] FIG. 2 is a partial perspective view of the anchor assembly shown in FIG. 1;

- [012] FIG. 3 is partial perspective view of the anchor assembly shown in FIG. 1;
- [013] FIG. 4 is a partial cross-sectional view of the anchor assembly shown in FIG. 1; and
- [014] FIG. 5 is a schematic view of another embodiment of an anchor assembly being seated and locked in an orthopedic device.
- [015] FIG 6A is a side view of an alternative anchor according to some embodiments.
- [016] FIG. 6B s a cross-sectional view of the anchor in FIG. 6A with an alternative locking mechanism according to some embodiments.
- [017] FIG. 6C is a top view of the anchor and locking mechanism in FIG. 6B.
- [018] FIG. 7A is a side view of an alternative locking mechanism according to some embodiments.
- [019] FIG. 7B is cross-sectional view of the locking mechanism in FIG. 7A.
- [020] FIG. 7C is a top view of the locking mechanism in FIG. 7A.
- [021] FIG. 8A is a cross-sectional view of a first position of a locking mechanism in an anchor according to some embodiments.
- [022] FIG. 8B is a cross-sectional view of a second position of a locking mechanism in an anchor according to some embodiments.
- [023] FIG. 9A is a side view of an orthopedic device assembly according to some embodiments.
- [024] FIG. 9B is a cross-sectional view of the orthopedic device assembly in FIG. 9A.
- [025] FIGS. 10A-10I illustrate different views of a multi-functional insertion instrument according to some embodiments.
- [026] FIGS. 11A and 11B illustrate different views of an alternative multi-functional insertion instrument according to some embodiments.

[027] FIGS. 12A-12D illustrate different views of an alternative multi-functional insertion instrument according to some embodiments.

[028] FIGS. 13A and 13B illustrate different views of an alternative orthopedic device assembly according to some embodiments.

[029] FIG. 14 illustrates yet another alternative orthopedic device assembly according to some embodiments.

[030] FIGS. 15A and 15B illustrate different views of an alternative multi-functional insertion instrument according to some embodiments.

DETAILED DESCRIPTION OF THE ILLUSTRATED EMBODIMENTS

[031] The following description of the preferred embodiments is merely exemplary in nature and is in no way intended to limit the invention, its application, or uses.

[032] With reference to FIGS. 1-4, a preferred embodiment of an anchor assembly 10 is illustrated. The anchor assembly 10 preferably includes an anchor 11 and a locking mechanism 30. Although the anchor 11 will be discussed in the context of an orthopedic screw, it is contemplated that the anchor 11 can be any type of anchoring element including, but not limited to, a hook, a pin, or a nail. In a preferred embodiment, the anchor 11 includes, concentric to a longitudinal axis 12, a head portion 14, a neck portion 18 and a shank portion 16. The head portion 14 connects to the shank portion 16 through the neck portion 18. The anchor assembly 10 is preferably constructed from any biocompatible material including, but not limited to, stainless steel alloys, titanium, titanium based alloys, or polymeric materials.

[033] In a preferred embodiment, the head portion 14 of the anchor 11 has a generally spherical shape and includes at least one resilient finger element 20. In another preferred embodiment, the head portion 14 includes four resilient finger elements 20. Preferably, located on either side of the resilient finger element 20 is an elongated groove 22. The grooves 22 may be configured and dimensioned to correspond with the end of a driving instrument (not shown) designed to engage the anchor 11, and consequently the anchor assembly 10.

[034] As best shown in FIG. 4, the generally spherical shape of the head portion 14 is configured and dimensioned to be received within a correspondingly shaped cavity 52 in an orthopedic device 50 which may be part of a spinal fixation system. In an exemplary embodiment, the orthopedic device 50 is a bone plate, but the orthopedic device can be any device, such as a spinal rod “tulip” style holder or a spinal spacer. The shape of the head portion 14 and the correspondingly shaped cavity 52 allows the anchor assembly 10 to pivot, rotate and/or move with respect to the orthopedic device 50. In another embodiment, instead of allowing the anchor assembly 10 to pivot, rotate and/or move with respect to the orthopedic device 50, the head portion 14 and the correspondingly shaped cavity 52 may be configured and dimensioned to keep the anchor assembly 10 in a fixed position. In an exemplary use, the head portion 14 of the anchor 11 is received in the cavity 52 of the orthopedic device 50 and the anchor assembly 10 is pivoted, rotated or moved until the desired orientation with respect to the orthopedic device 50 is met. The anchor assembly 10 is then locked in place, which is discussed in detail below, in the cavity 52 of the orthopedic device 50. In a preferred embodiment, the head portion 14 also includes texturing 24 that extends along at least a portion of the head portion 14. The texturing 24 on the head portion 14 provides additional frictional surfaces which aid in locking the anchor assembly 10 in place with respect to the orthopedic device 50.

[035] Turning back to FIGS. 1-3, in a preferred embodiment, the neck portion 18 of the anchor 11 integrally connects the head portion 14 with the shank portion 16. The diameter of the neck portion 18 is preferably dimensioned to match the minor diameter of the anchor 11. By having the diameter of the neck portion 18 dimensioned at least as large as the minor diameter of the anchor 11, the overall rigidity and strength of the anchor 11 is increased.

[036] In a preferred embodiment, the shank portion 16 of the anchor 11 includes a shaft 26 surrounded at least in part by a thread portion 28. The diameter of the shaft 26 is the minor diameter of the anchor assembly 10. In a preferred embodiment, the diameter of the shaft 26 remains generally constant from a proximal end of the shaft 26 toward a distal end of the shaft 26. The constant diameter of a majority portion of the shaft 26 allows for optimal anchor positioning when the anchor assembly 10 is inserted into a predetermined area in the bone tissue. The constant diameter also allows for varying the depth positioning of the anchor assembly 10 in the bone. For example, if a surgeon places the anchor assembly 10 into bone tissue at a first

depth and decides the placement is more optimal at a second, shallower depth, the anchor assembly 10 can be backed out to the second depth and still remain fixed in the bone. In another embodiment, the diameter of the shaft 26 may vary along its length, including increasing in diameter from the proximal end to the distal end or decreasing in diameter from the proximal end to the distal end.

[037] With continued reference to FIGS. 1-3, the thread portion 28 surrounding the shaft 26 extends, in a preferred embodiment, from the distal end of the shaft 26 to the neck portion 18. In another preferred embodiment, the thread portion 28 may extend along only a portion of shaft 26. The thread portion 28 is preferably a Modified Buttress thread but the thread can be any other type of threading that is anatomically conforming, including, but not limited to Buttress, Acme, Unified, Whitworth and B&S Worm threads.

[038] In a preferred embodiment, the diameter of the thread portion 28 decreases towards the distal end of the anchor 11. By having a decreased diameter thread portion 28 near the distal end of the anchor 11, the anchor 11 can be self-starting. In another preferred embodiment, anchor 11 may also include at least one flute to clear any chips, dust, or debris generated when the anchor assembly 10 is implanted into bone tissue.

[039] Looking again at FIGS. 1-4, the anchor assembly 10 preferably includes the locking mechanism 30. In a preferred embodiment, the locking mechanism 30 will lock the anchor assembly 10 with respect to the orthopedic device 50 thereby preventing the anchor assembly 10 from disengaging from the orthopedic device 50. The locking mechanism 30 preferably includes a locking member 32 which is configured and dimensioned to be received in an opening 34 in the anchor 11.

[040] In a preferred embodiment, the locking member 32 has a head member 36 and a shaft member 38. The head member 36 preferably includes an opening 40 for receiving a driving instrument (not shown). The opening 40 may also include threading 42 that is capable of threadingly engaging a driving instrument for reasons explained below. In a preferred embodiment, the shaft member 38 includes at least one protrusion 44 extending along at least a portion of the circumference of the shaft member 38. Focusing on FIG. 4, at least a portion of the

shaft member 38, in a preferred embodiment, also includes a hollow portion 46 which allows at least a portion of the shaft member 38 surrounding the hollow portion 46 to flex inwardly.

[041] Turning back to FIGS. 1 and 4, the opening 34, preferably, is generally annular and extends coaxially with the longitudinal axis 12 from the head portion 14 through the neck portion 18 into the shank portion 16. The opening 34 preferably also includes at least two recesses 47, 48, each recess 47, 48 extending along at least a portion of the circumference of the opening 34. Each recess 47, 48 is configured and dimensioned to accommodate the protrusion 44.

[042] In an exemplary use of the anchor assembly 10 with the orthopedic device 50, the orthopedic device 50 is first oriented and placed in the area of treatment. The orthopedic device 50 is then fastened to the bone tissue via at least one anchor assembly 10 which is received in at least one cavity 52 of the orthopedic device 50. Looking at FIG. 4, in a preferred embodiment, the cavity 52 has a generally spherical shape with a first diameter y at an upper portion 54. When viewed from the upper portion 54 to a lower portion 56, the diameter of the cavity 52 generally increases until approximately the middle portion of the cavity 52. The diameter of the approximately middle portion of the cavity 52 is a second diameter x . The diameter of the cavity 52 then decreases from the approximately middle portion of the cavity 52 to the lower portion 56, where the diameter of the cavity near the lower portion 56 is the same as or smaller than the first diameter y .

[043] In a preferred embodiment, the anchor assembly 10 passes through the cavity 52 until the head portion 14 of the anchor 11 abuts the top portion 54 of the cavity 52. As can be seen in FIG. 4, in a preferred embodiment, the diameter of the head portion 14 of the anchor 11 is generally the same width as diameter x . Since the top portion 54 of the cavity 52 has a diameter y , which is smaller than the diameter x , as the head portion 14 is brought into the cavity 52, the finger elements 20 of the head portion 14 resiliently bias inwardly reducing the diameter of the head portion 14 until the head portion 14 fits through top portion 54 of the cavity 52. Once the head portion 14 passes through the top portion 54, the resilient finger elements 20 return back to their original position as the head portion 14 is seated in the cavity 52.

[044] As best seen in FIGS. 3 and 4, in a preferred embodiment, once the anchor assembly 10 is seated in the cavity 52, the anchor assembly 10 can be locked in the cavity 52 by actuating the

locking mechanism 30. In a preferred embodiment, a user actuates locking mechanism 30 by pushing on the head member 36 of the locking member 32. The downward force moves the locking member 32 further into the opening 34. As the locking member 32 moves into the opening 34, the protrusion 44 will disengage from the recess 47. Since, in a preferred embodiment, the diameter of the shaft member 38 of the locking member 32 is generally equivalent to the diameter of the opening 34 near the neck portion 18 and the shaft portion 16, the shaft member 38 will flex inwardly, aided by the hollow portion 46, to accommodate the protrusion 44 once it disengages from the recess 47. The locking member 32 will continue to move further into opening 34 until the protrusion 44 engages the recess 48 at which point the head member 36 will be seated between the resilient finger elements 20 of the head portion 14. The anchor assembly 10 is now locked in the cavity 52 since the head member 36, once seated between the resilient finger elements 20, prevents the resilient finger elements 20 from flexing inwardly. It is important to note that the disengagement of protrusion 44 from recess 47 and the engagement of the protrusion 44 with the recess 48 (and vice versa) provides the user with audible and/or tactile feedback allowing the user to quickly and easily confirm the locked or unlocked status of the anchor assembly 10.

[045] As mentioned earlier, the head portion 36 includes the opening 40 which may include threading 42. The threading 42 in opening 40 engages a driving instrument (not shown) allowing a user to pull on the locking mechanism 30 thereby unlocking the anchor assembly 10 in the event a user wants to disengage the anchor assembly 10 from the orthopedic device 50.

[046] In another exemplary use of the anchor assembly 10 with the orthopedic device 50, the orthopedic device 50 is first oriented and placed in the area of treatment. The orthopedic device 50 is then fastened to the bone tissue via at least one anchor assembly 10 which is received in at least one cavity 52 of the orthopedic device 50. In this exemplary use, after the anchor assembly 10 is seated in the cavity 52, but before the anchor assembly 10 is locked in the cavity 52, the anchor assembly 10 is pivoted, rotated or otherwise moved until the desired orientation with respect to the orthopedic device 50 is met. The anchor assembly 10 is then locked in place at that desired orientation by actuating the locking mechanism 30 as discussed above.

[047] In this exemplary use, to lock the anchor assembly 10 at the desired orientation another preferred embodiment of the anchor assembly 10, and more specifically, another preferred embodiment of the locking mechanism 30 is necessary. In this preferred embodiment, the locking mechanism 30 is configured and dimensioned to resiliently bias the resilient finger elements 20 of head portion 14 outwardly when the locking mechanism 30 is pushed from the first, unlocked position, to the second, locked position. By resiliently biasing the finger elements 20 outwardly, the finger elements 20 will push against the walls of the cavity 52 thereby locking the anchor assembly 10 in place in the desired orientation. To resiliently bias the finger elements 20 outwardly, the head member 36 of the locking mechanism 30, preferably, is configured and dimensioned to include tapering surfaces and a diameter larger than the diameter of the opening 34 near the head portion 14.

[048] Turning to FIG. 5, a preferred embodiment of the anchor assembly 100 is shown. The anchor assembly 100 is similar to anchor assembly 10, as such, only the differences between the two embodiments are addressed herein. The anchor assembly 100 preferably includes an anchor 110 and a locking mechanism 130. In a preferred embodiment, the anchor 110 includes, concentric to a longitudinal axis 112, a head portion 114, a neck portion 118 and a shank portion 116. The head portion 114 connects to the shank portion 116 through the neck portion 118. In a preferred embodiment, the head portion 114 of the anchor 110 has a generally spherical shape and includes a resilient ring element 120 captured between an upper and lower end of the head portion 114.

[049] With continued reference to FIG. 5, in a preferred embodiment, the locking mechanism 130 will lock the anchor assembly 100 with respect to the orthopedic device 150 thereby preventing the anchor assembly 100 from disengaging from the orthopedic device 150. The locking mechanism 130 preferably includes a locking member 132 which is configured and dimensioned to be received in an opening 134 in the anchor 110.

[050] In an exemplary use of the anchor assembly 100 with the orthopedic device 150, the orthopedic device 150 is first oriented and placed in the area of treatment. The orthopedic device 150 is then fastened to the bone tissue via at least one anchor assembly 100 which is received in at least one cavity 152 of the orthopedic device 150. In a preferred embodiment, the anchor

assembly 100 passes through the cavity 152 until the head portion 114 of the anchor 110 abuts a top portion of the cavity 152. Since the top portion of the cavity 152 has a diameter that is smaller than the diameter of the head portion 114, to fit the head portion 114 into the cavity 152, the resilient ring 120 is resiliently bias inwardly, reducing the diameter of the head portion 114, until the head portion 14 fits through top portion of the cavity 152. Once the head portion 114 passes through the top portion of the cavity 152, the ring 120 returns back to its original position as the head portion 114 is seated in the cavity 152.

[051] With continued reference to FIG. 5, in a preferred embodiment, once the anchor assembly 100 is seated in the cavity 152, the anchor assembly 100 can be locked in the cavity 152 by actuating the locking mechanism 130. In a preferred embodiment, a user actuates locking mechanism 130 by pushing on the locking member 132. The downward force moves at least a portion of the locking member 132 into opening 134. The anchor assembly 100 is now locked in the cavity 152 since the locking member 132, once seated in the opening 134, prevents the ring 120 from flexing inwardly.

ADDITIONAL EMBODIMENTS OF LOCKING BONE SCREW ASSEMBLIES

[052] Additional embodiments of an alternative locking bone screw assembly including an anchor and locking mechanism are described. The assembly allows the anchor to be secured to an orthopedic device, such as a bone plate. The alternative locking bone screw assembly comprises an anchor with splaying arms and an insertable locking mechanism that forces the arms to splay, thereby expanding the arms of the anchor. When the arms of the anchor are expanded, the arms press against the surface of the orthopedic device, thereby causing fixation between the anchor the orthopedic device. For example, the anchor can be positioned in an aperture of an orthopedic plate member. Before expansion of the anchor, the anchor is free to move about in multiple orientations and directions relative to the orthopedic plate. Following expansion, the walls of the anchor are pressed firmly against the walls of the orthopedic plate member, thereby helping to retain the anchor within the plate member and form an assembly. In other words, in some embodiments, there is no locking interference between the anchor and the orthopedic plate member prior to expansion and splaying of the anchor. After the walls of the anchor have been splayed into a different locking diameter, the anchor is securely fixed to the

plate member. The advantage of this assembly is that it includes a locking mechanism that does not require an axial force to overcome a locking element or a certain amount of thread purchase to operate the locking feature. In addition, the position of the locking mechanism provides a clear visual indication of whether the anchor is locked or unlocked. Moreover, the anchor can be easily removed from the orthopedic device without ruining the orthopedic device using the locking mechanism described herein.

[053] FIG 6A is a side view of an alternative anchor according to some embodiments. The anchor 211 includes a head portion 214, a neck portion 218 and a shank portion 216. The anchor 211 is designed to fit through an aperture of an orthopedic device (e.g., a plate member) to secure the device to a treatment site.

[054] The anchor head portion 214 comprises an upper opening for receiving a locking mechanism 230, as shown in FIG. 6C. The head portion 214 comprises two or more resilient members in the form of fingers or arms 220 that are separated by grooves 222. In the illustrated embodiment, the head portion 214 comprises four arms 220, each of which is separated by a single groove. The arms 220 are advantageously capable of splaying outwardly from a central axis of the anchor 211 when a force is applied. In some embodiments, the splaying force can be applied by inserting a locking mechanism 230 having splay fingers 232 (shown in FIGS. 7A-7C) into the head portion 214. The locking mechanism 230 forces the outward expansion of the arms 220 of the head portion 214.

[055] While in the illustrated embodiment, the head portion 214 comprises four arms 220 separated each by a groove 222, such that each adjacent groove 222 is at approximately a 90 degree angle from one another, the head portion 214 can also include other configurations. For example, the head portion 214 can include three arms, each of which is separated by grooves. In this situation, adjacent grooves can be approximately 120 degrees away from another. In some embodiments, more than four arms 220 are formed in the head portion, such as five, six, seven, eight or more. In addition, the adjacent grooves 222 can also be separated by greater than or less than 90 degree angles. Moreover, while the grooves 222 are illustrated as symmetrical, in other embodiments, the grooves 222 are asymmetrical.

[056] The anchor head portion 214 transitions into the shank portion 216 via the neck portion 218. In some embodiments, the neck portion 218 includes one or more relief cuts 219 that are machined along at least a portion of the neck. The relief cuts 219 advantageously accommodate and facilitate the splaying of the arms 220 of the head portion. The orientation of the relief cuts 219 allows the arms to splay easier in their outward directions. In some embodiments, the relief cuts 219 are positioned at a bottom end of a pocket of the anchor head to enhance the ability of arms to flex outwardly away from the central axis of the anchor.

[057] The shank portion 216 comprises an extended shaft that can be inserted into a bone member. While the shank portion 216 is illustrated as having no threads, in other embodiments, the shank portion 216 comprises a plurality of threads that extend along at least a portion of its length. The threads can be single diameter threads or dual diameter threads.

[058] FIG. 6B is a cross-sectional view of the anchor 211 in FIG. 6A with a locking mechanism 230 inserted therein according to some embodiments. The locking mechanism 230 includes a plurality of splay fingers 232, each of which engages an inner wall 227 of at least one arm 220 of the head portion 214. In some embodiments, one or more of the inner walls 227 of the head portion arms 220 include a groove or slot 234 for receiving a splay finger of the locking mechanism 230, as shown in FIG. 6C. As the locking mechanism 230 is inserted downwardly into the head portion 214, the splay fingers 232 of the locking mechanism slide down the slots 234 in the head portion and force the head portion to splay and expand outwardly. In some embodiments, the splay fingers 232 of the locking mechanism are tapered. The slots 234 for receiving the splay fingers 232 in the anchor can also be tapered. Advantageously, in addition to facilitating the splaying of the anchor arms, the slots 234 in the anchor 211 also assist in guiding the locking mechanism 230 into the proper orientation within the anchor 211.

[059] FIG. 6C is a top view of the anchor and locking mechanism in FIG. 6B. As shown from this viewpoint, the splay fingers 232 of the locking mechanism 230 are slidably inserted into the slots 234 along the inner wall of the anchor arms 220, thereby forcing outward expansion of the head of the anchor.

[060] The top of the locking mechanism 230 is visible in FIG. 6C. As shown in the figure, the top of the locking mechanism 230 can include a central circular portion 233 that is suitable for

instrument engagement. In addition, the central circular portion 233 of the locking mechanism 230 advantageously maintains a centralized locking force between the locking mechanism 230 and the anchor 211, thereby allowing for an equal force distribution amongst the splay fingers 232.

[061] FIG. 7A is a side view of an alternative locking mechanism according to some embodiments. The locking mechanism 230 includes an upper head portion 236 comprising one or more splay fingers 232 and a lower shaft portion 238. In the illustrated embodiment, the locking mechanism 230 includes four splay fingers 232a, 232b, 232c and 232d. The splay fingers 232 engage the inner walls of the arms of the anchor head, thereby promoting splaying of the anchor head.

[062] As shown in FIG. 7A, the lower shaft portion 238 of the locking mechanism can include one or more compression slots 241. In the illustrated embodiment, the compression slot 241 extends from a point within the shaft portion 238 to a distal end of the shaft portion 238. When the locking mechanism 230 is inserted into the anchor 211, the lower shaft portion 238 can compress against inner walls of the anchor (as shown in FIG. 6B), thereby advantageously facilitating insertion of the locking mechanism 230 within the anchor 211.

[063] FIG. 7C is a top view of the locking mechanism in FIG. 7A. The splay fingers 232a, 232b, 232c and 232d are illustrated as symmetrical about the central circular portion 233. This symmetry advantageously allows forces to be evenly distributed around the locking mechanism. In other embodiments, the splay fingers 232 need not be symmetrical about the central circular portion.

[064] FIG. 8A is a cross-sectional view of a first position of a locking mechanism 230 in an anchor 211 according to some embodiments. As shown in the figure, portions of the outer arms 220 of the anchor 211 contact the inner walls of an orthopedic device in the form of a plate 250; however, as the locking mechanism 230 is not fully inserted down through the anchor 211, the arms 220 of the anchor are not splayed outwardly and thus, the anchor 211 is free to move about relative to the plate 250. In this first position, the locking mechanism 230 is in the process of being inserted into the head portion of the anchor 211. As shown in the figure, the top of the locking mechanism 230 is proud above a top surface of the anchor 211. In this first position, the

arms 220 of the anchor 211 are not yet fully splayed and pressed firmly against the inner wall, such that the orientation and position of the anchor 211 can still be adjusted relative to the plate 250.

[065] FIG. 8B is a cross-sectional view of a second position of a locking mechanism 230 in an anchor 211 according to some embodiments. In this figure, the locking mechanism 230 has been inserted further down the anchor 211, thereby forcing the arms 220 of the anchor to splay outwardly. When the anchor arms 220 are splayed outwardly, they press against the inner walls of the plate 250, thereby forming a secure fit. The position and angle of the anchor 211 is thus fixed relative to the plate 250, thereby forming a secure assembly.

[066] FIG. 9A is a side view of an orthopedic device assembly 300 according to some embodiments. The assembly 300 comprises a plate member 250 secured to an anchor 211. By inserting a locking mechanism 230 into an upper opening of the anchor 211, arms of the anchor can splay outwardly, thereby securing the anchor 211 to the plate member 250.

[067] FIG. 9B is a cross-sectional view of the orthopedic device assembly in FIG. 9A. From this viewpoint, one skilled in the art can appreciate that the locking mechanism 230 is in the process of being fully inserted into anchor 220 to thereby secure the anchor 220 to the plate member 250.

[068] Methods of using the locking assembly are now provided. In some embodiments, an orthopedic device, such as a plate member, can be oriented and placed in an area of treatment. The orthopedic device includes one or more apertures for receiving anchor members to secure the orthopedic device to the treatment area. An anchor member can be inserted through an aperture of the orthopedic device. The anchor member is free to move in different positions and/or orientations relative to the orthopedic device until a locking mechanism is inserted therein. The locking mechanism can comprise one or more splaying arms that engage the inner walls of the anchor member, thereby causing expansion of the anchor member within the orthopedic device. Once the anchor member is expanded, the anchor member is secured to the orthopedic device, thereby forming a secure assembly.

[069] FIGS. 13A and 13B are different views of an alternative locking bone screw assembly including an anchor and locking mechanism in accordance with some embodiments. The assembly allows the anchor to be secured to an orthopedic device, such as a bone plate. In some embodiments, the locking mechanism is preassembled with the anchor, such that the anchor and locking mechanism are delivered simultaneously to a surgical site. By having the locking mechanism be preassembled with the anchor, this saves the surgeon time and reduces the need to guide the locking mechanism to the anchor during a surgical procedure. In other words, by having a locking mechanism that is preassembled with the anchor, this eliminates the difficulty of engaging the locking mechanism with the anchor *in situ*.

[070] As shown in FIGS. 13A and 13B, the alternative locking bone screw assembly comprises an anchor 711 and a locking mechanism 730 received within the anchor 711. The anchor 711 comprises a head portion 714, a neck portion 718, and a shank portion 716 that extends from the neck portion 718. The anchor 711 includes an inner opening that is configured to receive the locking mechanism 730. The locking mechanism 730 can be in the form of a set screw having its own head 730 and shaft 750, and can be configured to radially expand at least a portion of the anchor 711 as it is downwardly inserted into the inner opening, thereby securing the anchor to an orthopedic device, such as plate 150.

[071] In some embodiments, the anchor 711 includes a shank portion 716 that is tapered and insertable into a bone member. In some embodiments, the tapered portion is at least partially or completely threaded. In some embodiments, the threads can be single-lead threads, while in other embodiments, the threads can be dual-lead threads. As shown in FIG. 13A, the shank portion 716 extends from a neck portion 718 that is substantially or completely unthreaded.

[072] The head portion 714, which extends on the other side of the neck portion 718, comprises a rounded portion that is broken into four spherical quadrants 720. Each of the quadrants 720 is separated from another via a cut or slit. In some embodiments, the quadrants 720 are deformable relative to other portions (e.g., the neck portion 718 and shank portion 716) of the anchor 711. In some embodiments, each of the quadrants 720 includes a recess 719 formed on an outer surface, such that the head portion 714 includes four recesses. These recesses 719 advantageously provide a region that can be gripped or grasped by an insertion instrument, such as shown in

FIGS. 15A and 15B and discussed in more detail below. While the present embodiment illustrates the head portion 714 as having four recesses 719, in other embodiments, the number of recesses can vary. For example, in other embodiments, the head portion 714 can include a total of two recesses 719 – one formed on each of two opposed quadrants.

[073] The four quadrants 720 of the head portion 714 surround an inner opening of the anchor 711. As shown in FIG. 13B, the inner opening extends through the head portion 714, neck portion 718 and at least partially into the shank portion 716 of the anchor 711. Advantageously, the inner opening is configured to receive the locking mechanism 730 therethrough, thereby causing radial expansion of the head portion 714 to effectively secure the bone screw assembly to an orthopedic device.

[074] As shown in FIGS. 13A and 13B, the anchor 711 includes a number of internal features that accommodate the locking mechanism 730. The anchor 711 includes internal threads 717 that extend along at least a portion of the length of the shank portion 716. These internal threads 717 engage with threads on the locking mechanism 730. In other words, the anchor 711 has a threaded inner diameter that is counterbored to accept the threads of the locking mechanism 730. The threaded engagement between the anchor 711 and the locking mechanism 730 advantageously provides a secure means to secure the anchor to the locking mechanism. This is particularly beneficial when the locking mechanism 730 is preassembled to the anchor 711, as this prevents the locking mechanism 730 from inadvertently backing out from the anchor 711 as both components are being delivered to a surgical site.

[075] In addition to the internal threads 717, the interior of the anchor 711 also includes inner recesses or reliefs 729 to accommodate the head portion 714 of the locking mechanism 730. As shown in FIG. 13A, each of the quadrants 720 includes an inner relief 729 formed along an inner surface. The reliefs 729 advantageously provide a region in which the head portion 714 of the locking mechanism 730 is designed to contact and nest within. When the head portion 714 of the locking mechanism 730 is nested and positioned within the inner reliefs 729, the spherical quadrants 720 of the anchor 711 advantageously retract radially inward to capture the locking mechanism 730 therein.

[076] In addition to the internal threads 717 and inner reliefs 729, the anchor 711 also includes inner relief cuts 739. In some embodiments, the inner relief cuts 739 are formed within the inner reliefs 729 of each of the quadrants. The inner relief cuts 739 are cut-out portions designed to ease expansion of the quadrants 720 while the locking mechanism 730 is downwardly inserted into the anchor 711. As the locking mechanism 730 is inserted into the anchor 711, the head 740 of the locking mechanism causes outward expansion of the head portion 714 of the anchor 711, due in part to the relief cuts 739. Once the head 740 of the locking mechanism 730 is received within the inner reliefs 729 of the quadrants, the head portion 714 of the anchor 711 can retract radially inward to tighten and capture the locking mechanism 730 therein.

[077] In some embodiments, the locking mechanism 730 comprises a head 740 and a threaded shaft 750. As shown in FIG. 13A, the head 740 of the locking mechanism 730 has a greater diameter than the threaded shaft 750, and thereby causes greater expansion of the head portion 714 of the anchor 711. As discussed above, the locking mechanism 730 is preferably preassembled in the anchor 711 such that the two components can be delivered simultaneously at or near a surgical site.

[078] Methods of using the locking assembly preassembled to the anchor in FIGS. 13A and 13B are now provided. In some embodiments, an orthopedic device, such as a plate member, can be oriented and placed in an area of treatment. The plate member can be a thoracolumbar plate, a cervical plate or any other plate used in spinal surgery. Regardless of the orthopedic device, the orthopedic device includes one or more apertures for receiving anchor members to secure the orthopedic device to the treatment area. An anchor member can be inserted through an aperture of the orthopedic device and inserted into bone. The anchor member can include a head portion, neck portion and a shank portion. The head portion includes four quadrants that are resilient and flexible. The anchor member comes preassembled with an internal locking assembly, such as that shown in FIGS. 13A and 13B. The anchor member is free to move in different positions and/or orientations relative to the orthopedic device until the locking member is forced further downward into anchor member. As the locking member is forced downwardly into the anchor member, this causes the head portion of the anchor member to expand within the aperture of the orthopedic device, thereby securing the anchor member to the orthopedic device. The locking member can be downwardly inserted until it resides within an inner relief zone

formed within the head of the anchor member. When it resides in this zone, the resilient quadrants of the head portion retract radially inward, to thereby help capture and maintain the locking mechanism therein. One or more anchors can be used to secure the orthopedic device to bone. Furthermore, in some embodiments, the orthopedic device including the one or more anchors can be accompanied by a number of other surgical implants, including fusion devices, prosthetic devices, stabilization members (such as rod members and pedicle screws) and other implants used in spine surgery.

[079] FIG. 14 is a perspective view of an alternative locking bone screw assembly including an anchor and locking mechanism in accordance with some embodiments. Advantageously, the locking mechanism can be preassembled within the anchor such that the two components can be delivered simultaneously to a surgical site. The anchor 811 includes many similar features as prior embodiments, including a head portion 814, neck portion 818, and a shank portion 816. The head portion 814 comprises resilient quadrants 820 separated by cuts or slits that are designed to deflect and expand outwardly via insertion of a locking mechanism 830. Each of the quadrants 820 includes an inner relief 816 that is designed to contact and maintain the locking mechanism 830 therein. In addition, each of the quadrants 820 can include an inner relief cut 1019 (shown in FIGS. 16A and 16B) that are designed to provide flexibility to the quadrants 820.

[080] The locking mechanism 830 is similar to the locking mechanism in FIGS. 13A and 13B, in that it is in the form of a set screw including a head 840 and a shaft 850. However, unlike the locking mechanism in FIGS. 13A and 13B, the locking mechanism 830 also includes a flanged portion 855 between the head 840 and shaft 850. The flanged portion 855, which extends around a circumference of the locking mechanism 830, is designed so as to be received within the inner relief cuts 819 of the anchor 811. In some embodiments, the flanged portion 855 extends around only a portion of a circumference of the locking mechanism 830. Providing a flanged portion 855 on the locking mechanism 830 has a number of advantages. For example, the addition of the flanged portion 855 provides for easier expansion of the head portion 814 of the anchor 811. In addition, as the flanged portion 855 is received within the inner relief cuts 819 of the head portion 814 of the anchor 811, this provides one more mechanism for preventing the back out of the locking mechanism 830 from the anchor 811.

[081] Methods of using the locking assembly preassembled to the anchor in FIG. 14 are now provided. In some embodiments, an orthopedic device, such as a plate member, can be oriented and placed in an area of treatment. The plate member can be a thoracolumbar plate, a cervical plate or any other plate used in spinal surgery. Regardless of the orthopedic device, the orthopedic device includes one or more apertures for receiving anchor members to secure the orthopedic device to the treatment area. An anchor member can be inserted through an aperture of the orthopedic device and inserted into bone. The anchor member can include a head portion, neck portion and a shank portion. The head portion includes four quadrants that are resilient and flexible. The anchor member comes preassembled with an internal locking assembly. The internal locking assembly can include a flanged portion as shown in FIG. 14. The anchor member is free to move in different positions and/or orientations relative to the orthopedic device until the locking member is forced further downward into anchor member. As the locking member is forced downwardly into the anchor member, this causes the head portion of the anchor member to expand within the aperture of the orthopedic device, thereby securing the anchor member to the orthopedic device. The flanged portion of the locking member, which is wider than the distal threaded portion of the locking member, assists in expanding the head portion of the anchor member. The locking member can be downwardly inserted until it resides within an inner relief zone formed within the head of the anchor member. When it resides in this zone, the resilient quadrants of the head portion retract radially inward, to thereby help capture and maintain the locking mechanism therein. One or more anchors can be used to secure the orthopedic device to bone. Furthermore, in some embodiments, the orthopedic device including the one or more anchors can be accompanied by a number of other surgical implants, including fusion devices, prosthetic devices, stabilization members (such as rod members and pedicle screws) and other implants used in spine surgery.

MULTI-FUNCTIONAL INSTRUMENTS

[082] Novel instruments are now described that cooperate with the locking bone screw assemblies described above, and in particular, those in FIGS. 6A-9B. The instruments are advantageously multi-functional and can help to both drive an anchor into a bone member and provide the locking mechanism to secure the anchor to an orthopedic device such as a plate

member. The multi-functional instruments can advantageously provide a novel “impact to lock” feature that secures the anchor to orthopedic device.

[083] FIGS. 10A-10I illustrate different views of a multi-functional insertion instrument according to some embodiments. The insertion instrument 400 comprises a proximal portion 402 comprising a handle 410 and a distal portion 405. The distal portion 405 can hold a locking mechanism, such as those shown in FIGS. 7A-7C.

[084] The multi-functional insertion instrument 400 is configured to advantageously accommodate three different features: a drive feature, a cocking/setting feature and a catch and release feature. The drive feature allows an anchor, such as that shown in FIGS. 6A-6C, to be driven into a bone member. The cocking feature prepares a locking mechanism, such as that shown in FIGS. 7A-7C, for impaction into the anchor so as to secure the anchor to an orthopedic device. The catch and release feature operates with the cocking feature, and serves to forcefully release the locking mechanism into the anchor. The catch and release feature uses an impaction force to drive the locking mechanism into the anchor, thereby causing expansion of the anchor to secure the anchor to an orthopedic device. The instrument thus relies on a novel “impact to lock” concept that is not found in other instruments. The features of the instrument 400 that support these multiple features are now discussed in detail.

[085] FIG. 10A illustrates a side cross-sectional view of the multi-functional insertion instrument 400. As shown in the figure, a number of features are enclosed within a housing 411 of the handle 410 in a proximal portion 402 of the instrument. A drive shaft 419, which relates to the drive feature, extends from within the handle 410 to a distal portion 405 (shown in FIG. 10B) of the instrument. A cocking sleeve 422 also extends from within the handle 410 to a more distal portion outside of the handle of the instrument. The cocking sleeve 422 moves in contact with one or more cocking pins 426 to move a hammer shaft 431 axially along the instrument. The cocking pins 426 and hammer shaft 431 are fully contained within the handle 410. The cocking sleeve 422, cocking pins 426, and hammer shaft 431 relate to the cocking feature that prepares a locking mechanism for impact to lock. The hammer shaft 431 interacts with catch pins 442 which capture the hammer shaft prior to impact to lock. A button 452 is provided to release the hammer shaft 431 from the catch pins 442, thereby forcing a locking mechanism on a

distal end of the instrument 400 into an anchor. The catch pins 442 and button 452 thus relate to the release feature of the instrument.

[086] Instrument components related to the drive feature are shown in FIG. 10C. FIG. 10C illustrates a perspective view of an interior section of the handle 410, as well as a drive shaft 419 that extends through the interior section. The drive shaft 419, which can be used to drive an anchor into bone, includes a keyed pattern portion 463 that mates with a complementary keyed pocket 461 formed on a flat surface 421 within the handle 410. While in the illustrated embodiment, the keyed pattern portion 463 of the drive comprises a plurality of extending protrusions, other designs are also possible so long as it mates and aligns with the keyed pocket 461. For example, in some embodiments, the pattern portion can comprise a parallelogram with a plurality of edges that rests in a complementary pocket within the handle. The alignment between the keyed pattern portion 463 of the drive and the keyed pocket 461 within the handle advantageously provides an anti-torsion feature that allows the handle 410 to rotate and drive an anchor into bone, while still maintaining the ability to perform the cocking feature and catch and release feature discussed above.

[087] Instrument components related to the cocking feature are shown in FIGS. 10D and 10E. FIG. 10D illustrates a perspective cross-sectional view of an interior section of the handle 410, including a cocking sleeve 422 and cocking pins 426. FIG. 10E also illustrates a perspective cross-sectional view of an interior section of the handle 410 and further includes the shaft hammer 431.

[088] As shown in FIG. 10D, the instrument 400 includes a cocking shaft 422 that extends beyond a distal portion of the handle. The cocking shaft 422 is configured to move up and down axially along a length of the handle. In some embodiments, the cocking shaft 422 is operated manually, such as by fingers of a user.

[089] The cocking shaft 422 is operably connected to a plurality of cocking pins 426. The cocking pins 426 extend through machined holes 416 formed in the flat surface 421 within the handle. Axial movement of the cocking shaft 422 simultaneously moves the cocking pins 426 along a length of the handle. While the illustrated embodiment illustrates three cocking pins 426, more or less than three pins can be provided to assist in setting the instrument.

[090] As shown in FIG. 10E, the top portion of the cocking pins 426 can contact the hammer shaft 431. The hammer shaft 431 comprises a disc portion 433 with an extended shaft 432 therein. The upper portion 434 of the hammer shaft 431 is chamfered to aid in the splaying of the catch pins, as shown in FIG. 10G. The distal portion of the hammer shaft 431 (not shown) is attached to a locking mechanism, such as that shown in FIG. 7A. When the cocking pins 426 move axially upward along the handle, the cocking pins 426 can push up against the bottom of the disc portion 433 of the hammer shaft 431, thereby causing the hammer shaft 431 to move upwards. As the hammer shaft 431 moves upwards, it is placed into a “firing position,” whereby it is captured and then released to perform an impact to lock feature, as discussed below.

[091] Instrument components related to the catch and release feature are shown in FIGS. 10F-10I. FIG. 10F illustrates a perspective cross-sectional view of the hammer shaft 431 prior to setting the hammer shaft into a firing position. FIG. 10G illustrates a front schematic view of the hammer shaft 431 in the process of being loaded into a firing position with the assistance of catch pins 482. FIG. 10H illustrates a perspective cross-sectional view of the hammer shaft 431 in the process of being loaded into a firing position. FIG. 10I illustrates a front schematic view of the hammer shaft 431 in the process of being released or fired.

[092] The catch and release feature of the instrument 400 relies on one or more catch pins 482 which travel in a set of grooves, one of which is positioned in the housing perpendicular to a central longitudinal axis and another which is positioned proximate a release button. The catch pins 482 are designed to capture the upper portion 434 of the hammer shaft 431 to retain the hammer shaft 431 prior to release and impaction. As shown in FIG. 10G, as the hammer shaft 431 moves upwardly, the upper portion 434 of the hammer shaft 431 pushes and contacts the catch pins 482. The chamfered surfaces of the upper portion 434 advantageously aid in the perpendicular splaying of the catch pins 482, as shown in FIG. 10G. After splaying outwardly, the catch pins 482 return to capture a bottom section of the upper portion 434 of the hammer shaft 434, thereby capturing and retaining the hammer shaft 431 in a position prior to firing and release. When the hammer shaft 431 is ready for release, the release button 452 can be pushed. Pushing the release button 452 causes the pins to 482 to splay outwardly at an angle away from a central longitudinal axis of the instrument 400, as shown in FIG. 10, thereby causing the hammer shaft 431 to be released from capture. The released hammer shaft 431 drops downwardly to

impact and lock the locking mechanism into the anchor, thereby securing the anchor to the orthopedic device.

[093] As shown in FIGS. 10F-10I, the hammer shaft 431 can comprise a spring member 479 positioned between the lower flat surface 421 and the upper chamfered portion 434 of the hammer shaft 431. Accordingly, the hammer shaft 431 can comprise a spring-loaded device that is capable of capture and release to force impact of the locking mechanism into the anchor.

[094] Advantageously, the instrument 400 can thus serve to both insert an anchor into a bone member and to secure the anchor to an orthopedic device. Both of these functions can be performed simultaneously or alternately.

[095] FIGS. 11A and 11B illustrate different views of an alternative multi-functional insertion instrument according to some embodiments. Like the previously described insertion instrument, the insertion instrument 500 is configured to both drive an anchor into a bone member and to impact a locking mechanism into the anchor to secure the anchor to an orthopedic device. However, unlike the previously described insertion instrument, instrument 500 includes a catch and release feature that is positioned outside of the handle body. FIG. 11A illustrates a perspective view of the insertion instrument 500, while FIG. 11B illustrates a close-up of the external catch and release feature of the instrument 500.

[096] As shown in FIG. 11A, the insertion instrument 500 includes a proximal portion 502 comprising a handle and a distal portion 505. The distal portion 505 can grasp a locking mechanism to impact into an anchor (not shown). Within the proximal portion, a hammer shaft 531 can move upwardly. The hammer shaft 531 can operate with a spring or coil member 579 to generate spring-loaded forces to impact a locking mechanism into an anchor.

[097] The catch and release feature of the insertion instrument is shown up close in FIG. 11B. The catch and release feature comprises a catch member 526 and a release member 522 that are operably connected and move together as a unit. The catch member 526 includes a catching location 538 for catching a pin member 535 on the hammer shaft 531. The release member 526 includes a release spring 523 that cooperates with the catch member 526. As the hammer shaft

531 is moved upwardly, the pin member 535 can be received in the catching location 538 of the catch member 526 in preparation for release and impaction.

[098] As shown in FIG. 11B, the catch member 526 includes a flange that acts as a stop for release member 522. The assembly includes a counterbore 537 in the handle 510 that accepts the flange and acts as a stop with the flange. To cock and set the instrument, the hammer shaft 531 is pushed axially upwards towards the handle 510. During this movement, the release spring 523 is compressed, thereby moving the catch member 526 off the main axis. This movement allows the pin member 535 of the catch member to gain access to the groove formed in the catching location 538. At this point, the hammer shaft 531 is prepared for release and impaction. To release the hammer shaft 531, the release member 526 can be pushed, thereby moving the catch member until the pin finds the groove in the catching location 538. Upon release of the hammer shaft 531, this causes impaction of a locking mechanism into an anchor, thereby securing the anchor to an orthopedic device.

[099] FIGS. 12A-12D illustrate different views of an alternative multi-functional insertion instrument according to some embodiments. The instrument 600 comprises a proximal portion 602 comprising a handle 610, a mid-sleeve 612 and a distal portion 605 that can be secured in series. These three components form a housing that encloses a firing spring 618 and firing cylinder 622 near the proximal portion 602 of the instrument, and a release spring 628 and swivel release 633 near the distal portion 605 of the instrument. The distal portion 605 of the instrument 600 also encloses a grasping element 661 having a distal tip 663 (as shown in FIG. 12D) for grasping the head of a locking mechanism.

[0100] The interaction of the swivel release 633 with the firing cylinder 622 helps form an impaction mechanism on the grasping element 661 that can force a locking mechanism into the head of an anchor. Unlike the previously described instruments, instrument 600 does not include a catch and release function. Rather, the instrument 600 relies on the alignment of the swivel release 633 to trigger an impaction mechanism to impact the locking mechanism into the head of the anchor, as discussed in more detail below.

[0101] The swivel release 633 comprises a body portion 634 that transitions into an extended narrower tip portion 635 via tapered sidewalls 637. The narrower tip portion 635 extends in the

direction of the handle 610. During use, the swivel release 633 is retained at least in part within a release spring 635. In its natural state, the swivel release 633 is not aligned with a central longitudinal axis of the instrument 600. In this state, the narrower tip portion 635 of the swivel release will be crooked and oriented at an angle (e.g., misaligned) from the central longitudinal axis. This misalignment creates an interference that compresses the firing spring 618.

[0102] To create an impaction force, the narrower tip portion 635 of the swivel release 633 should be placed in alignment with the central hole 625 formed in the firing cylinder 622. In some embodiments, to align the narrower tip portion 635 of the swivel release 633 with the central hole 625, a user presses down on the instrument, such as on the back end 652 of the handle 610. As the user presses down, the release spring 635 compresses and stabilizes the swivel release 633 such that the swivel release 633 is aligned with the central longitudinal axis of the instrument. Once the swivel release 633 aligns with the central longitudinal axis, the narrower tip portion 635 of the swivel release will fall into a swivel release hole 625 formed in the firing cylinder 622, and will be impacted by the firing cylinder hole 625 bottoming out on the swivel release 633. The impaction force is created by the compressed firing spring 618, and helps to drive out the grasping element 661 through the distal end of the instrument 600. With the locking mechanism connected to the grasping element 661, the locking mechanism can be impacted and inserted into an anchor to thereby secure the anchor to an orthopedic device.

[0103] FIGS. 15A and 15B illustrate different views of an alternative multi-functional insertion instrument 900 according to some embodiments. The insertion instrument 900 is particularly useful with the locking mechanism and anchor assembly of FIGS. 13A-14, but can also be used with other implants.

[0104] In some embodiments, the insertion instrument 900 comprises a cannulated shaft 902 and a driver 904 that extends through the cannulated shaft 902. In some embodiments, the driver 904 is designed to extend axially and rotate relative to the cannulated shaft 902. While the cannulated shaft 902 is designed to engage the anchor (e.g., anchor 711), the driver 904 is designed to engage the locking mechanism (e.g., locking mechanism 730) within the anchor.

[0105] In some embodiments, the insertion instrument 900 comprises a cannulated shaft 902 that comprises a sleeve or tubular body. A distal portion of the cannulated shaft 902 includes one or

more engagement portions 910 in the form of protrusions, fingers or tines. These engagement portions 910 are designed to engage at least a portion of the head portion of an anchor. For example, the engagements portions 910 can engage around a head portion of an anchor. In some embodiments, the engagement portions 910 can engage recesses (such as recesses 719 in FIGS. 13A and 13B) to assist in delivering the anchor preassembled with the locking mechanism. In addition, the engagement portions 910 help to stabilize the anchor while the driver 904 engages the locking mechanism therein.

[0106] In some embodiments, the driver 904 comprises an elongated body that extends through the cannulated shaft 902. A distal portion of the driver 904 comprises a locking mechanism driver 915 that is designed to engage with a locking mechanism. In some embodiments, the locking mechanism driver 915 comprises a hexalobular driver, while in other embodiments, the driver 915 comprises a trilobular driver. The driver 904 is designed to engage and rotate the locking mechanism. As the locking mechanism is turned, it moves toward the bottom of the counterbore and engages the tapered inner diameter of the spherical quadrants of the anchor head. As the locking mechanism advances, the locking mechanism (e.g., via tapered portions or wider flanged portions) deforms the spherical quadrants of the head portion radially outward against the spherical pocket of the bone screw, thus locking the anchor into an orthopedic device.

[0107] The invention being thus described, it will be obvious that the same may be varied in many ways. Such variations are not to be regarded as a departure from the spirit and scope of the invention, and all such modifications as would be obvious to one skilled in the art are intended to be included within the scope of the following claims.

WHAT IS CLAIMED IS:

1. An orthopedic assembly comprising:

a plate member having an upper surface and a lower surface, and an aperture extending through the upper surface and the lower surface;

an anchor received within the aperture, the anchor comprising a head portion, a neck portion and a shank portion, wherein at least a portion of the shank portion includes inner threads; and

a locking mechanism received within the anchor, the locking mechanism comprising a head and a shaft having outer threads, wherein the outer threads of the locking mechanism are configured to engage the inner threads of the shank portion,

wherein the locking mechanism is configured to expand the head portion of the anchor as the locking member is downwardly inserted into the locking mechanism, thereby securing the anchor to the plate member.

2. The orthopedic assembly of claim 1, wherein the anchor comprises four resilient quadrants.

3. The orthopedic assembly of claim 2, wherein each of the quadrants includes an inner relief.

4. The orthopedic assembly of claim 3, wherein the head of the locking mechanism is designed to contact the inner reliefs of the four quadrants.

5. The orthopedic assembly of claim 4, wherein the four quadrants of the anchor are designed to retract inwardly when the locking mechanism is in contact with the inner reliefs to thereby capture the locking mechanism within the anchor.

6. The orthopedic assembly of claim 1, wherein the anchor comprises relief cuts.

7. The orthopedic assembly of claim 6, wherein the locking member comprises a flange member configured to fit within the relief cuts.
8. The orthopedic assembly of claim 1, wherein at least a portion of the locking mechanism is tapered.
9. The orthopedic assembly of claim 1, wherein the locking mechanism and anchor are preassembled such that they can be delivered to surgical site simultaneously.
10. An orthopedic assembly comprising:
 - a plate member having an upper surface and a lower surface, and an aperture extending through the upper surface and the lower surface;
 - an anchor received within the aperture, the anchor comprising a head portion, a neck portion and a shank portion, wherein the head portion comprises resilient quadrants capable of radial expansion; and
 - a locking mechanism received within the anchor, the locking mechanism comprising a head and a shaft having outer threads, wherein the outer threads of the locking mechanism are configured to engage the inner threads of the shank portion,
 - wherein the locking mechanism is configured to expand the head portion of the anchor as the locking member is downwardly inserted into the locking mechanism, thereby securing the anchor to the plate member.
11. The orthopedic assembly of claim 10, wherein the plate member comprises a compression plate.
12. The orthopedic assembly of claim 10, further comprising a spacer body that is implanted along with the plate member and the anchor.

13. The orthopedic assembly of claim 10, wherein each of the resilient quadrants is separated from another by a slit.
14. The orthopedic assembly of claim 10, wherein each of the resilient quadrants includes an inner relief formed in an inner wall.
15. The orthopedic assembly of claim 14, wherein the head of the locking mechanism is configured to nest within the inner reliefs of the resilient quadrants.
16. The orthopedic assembly of claim 10, wherein the locking mechanism comprises a flanged portion.
17. The orthopedic assembly of claim 15, wherein the flanged portion extends around an entire circumference of the locking mechanism.
18. The orthopedic assembly of claim 10, wherein the locking mechanism and anchor are preassembled such that they can be delivered to surgical site simultaneously.
19. The orthopedic assembly of claim 9, wherein the head portion of the anchor retracts inwardly after the locking mechanism has been inserted fully into it, thereby helping to retain the locking mechanism therein.
20. The orthopedic assembly of claim 9, wherein the shaft of the locking mechanism is tapered.

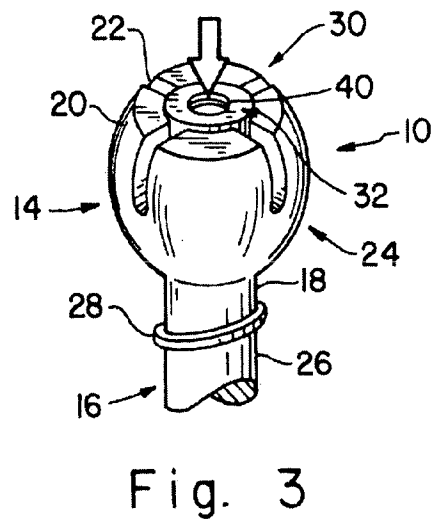
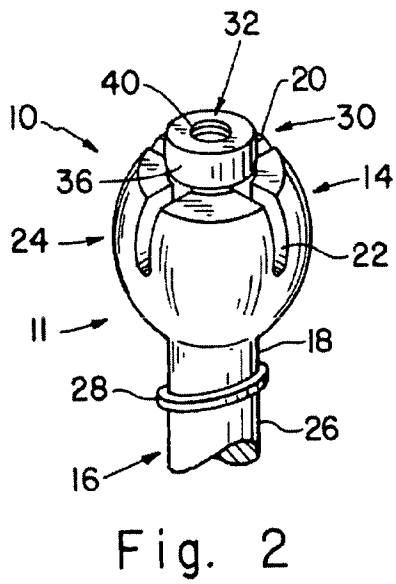
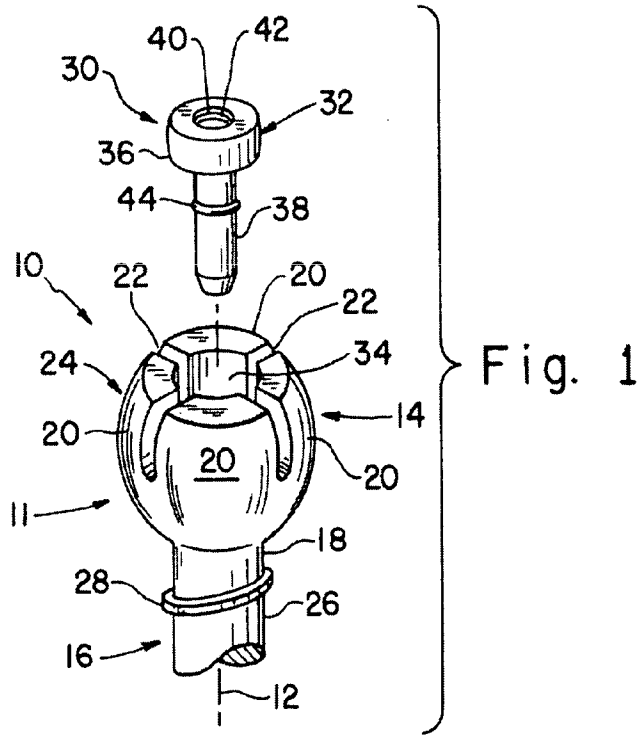

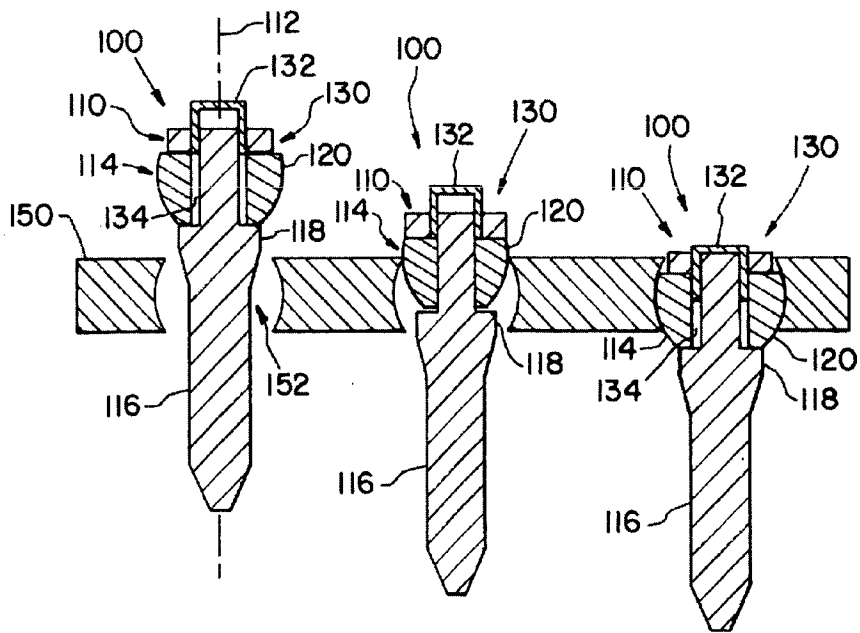
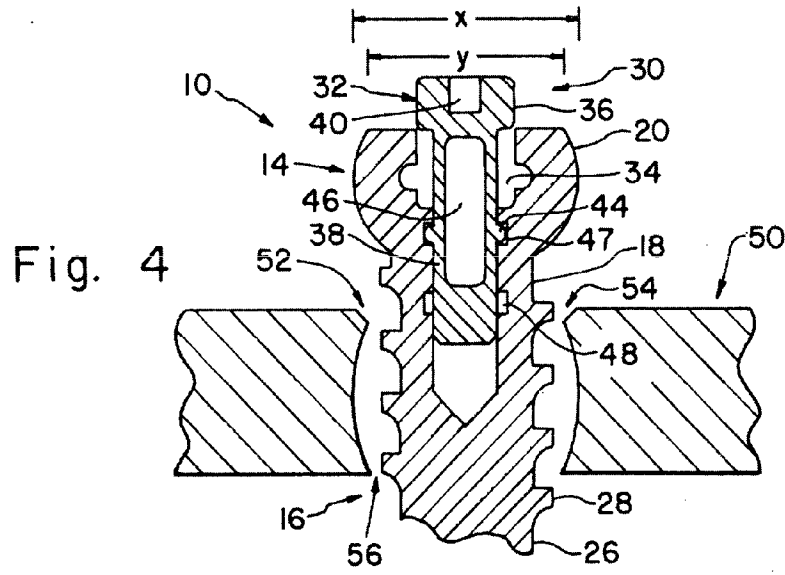

Fig. 5

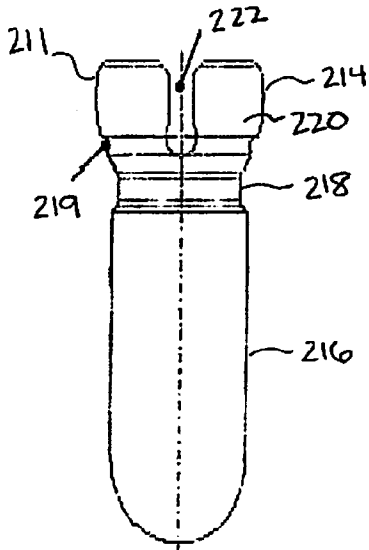

FIG. 6A

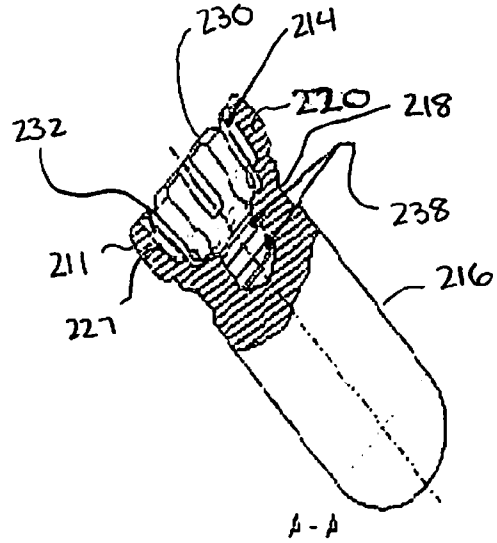

FIG. 6B

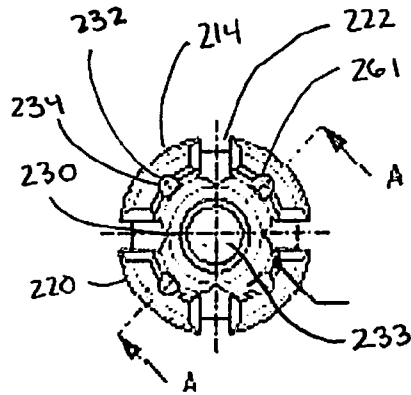

FIG. 6C

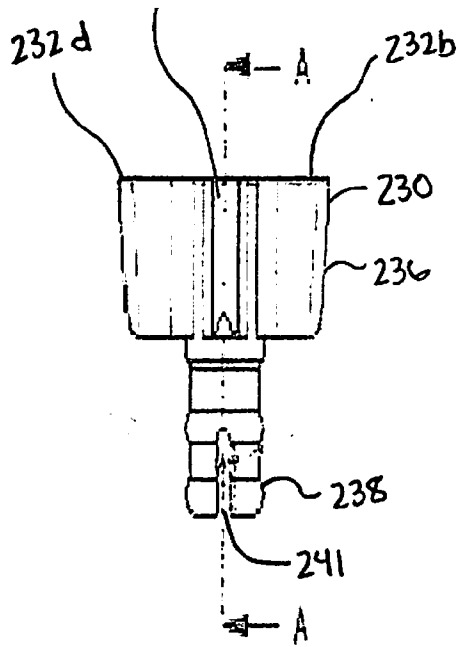

FIG. 7A

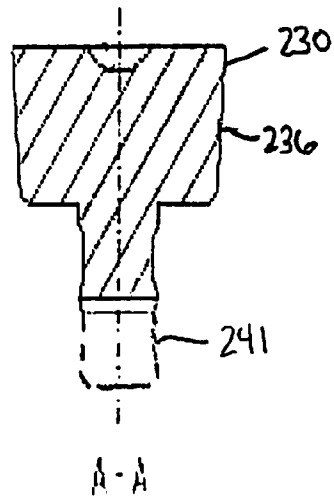

FIG. 7B

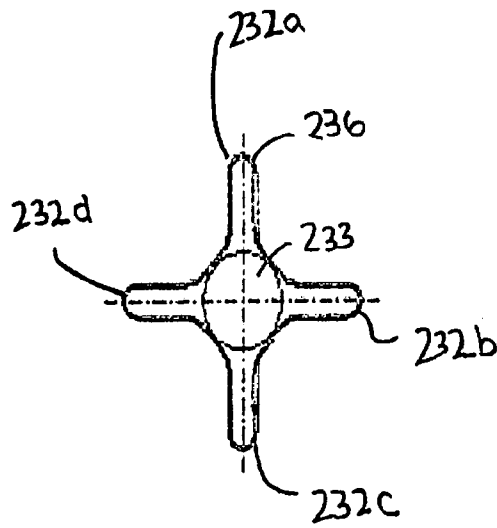

FIG. 7C

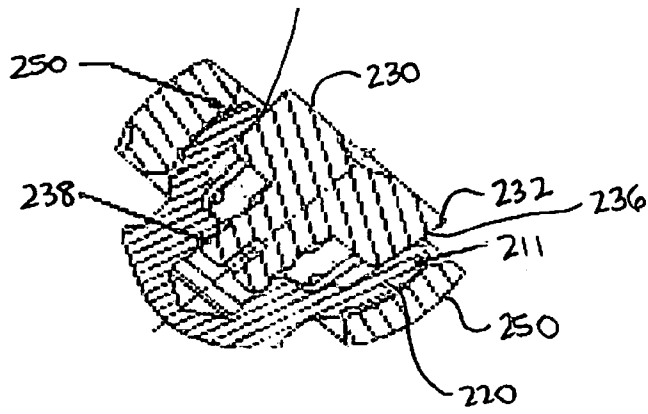

FIG. 8A

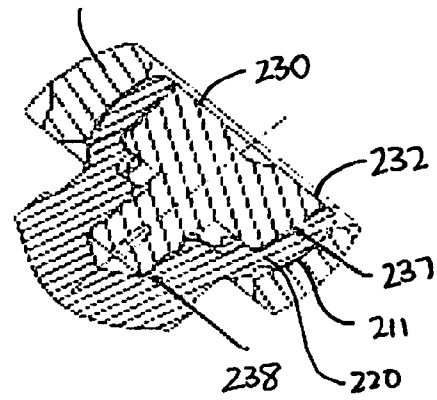

FIG. 8B

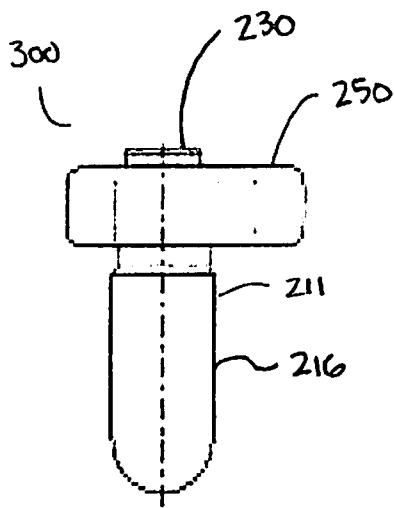

FIG. 9A

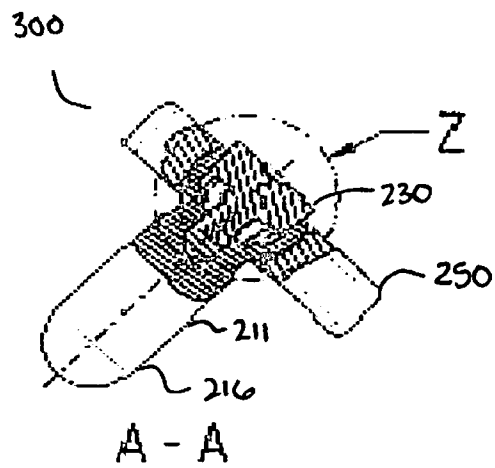

FIG. 9B

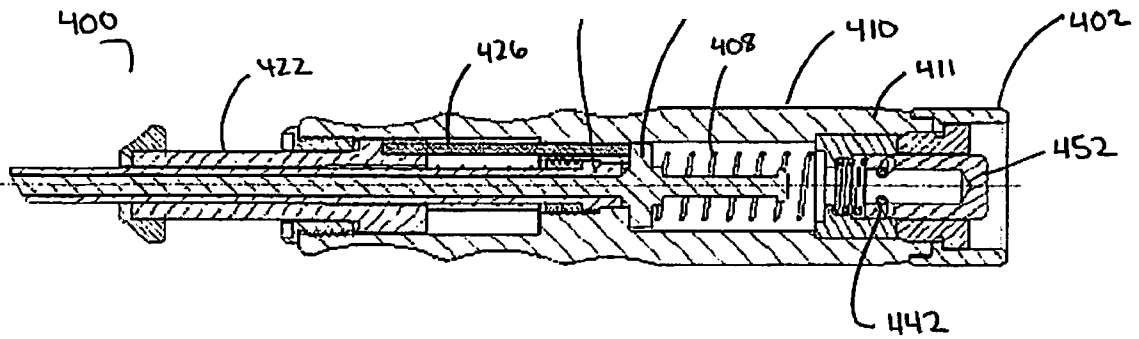

FIG. 10A

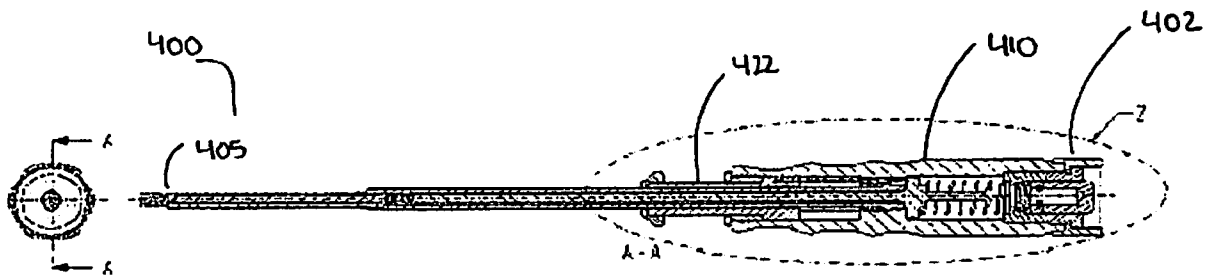

FIG. 10B

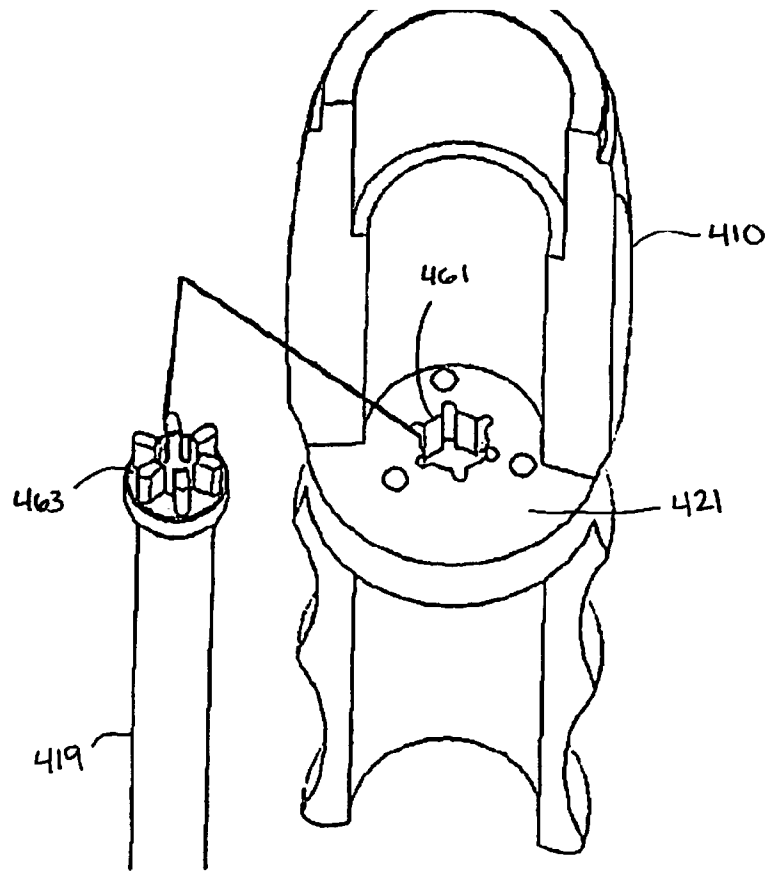

FIG. 10C

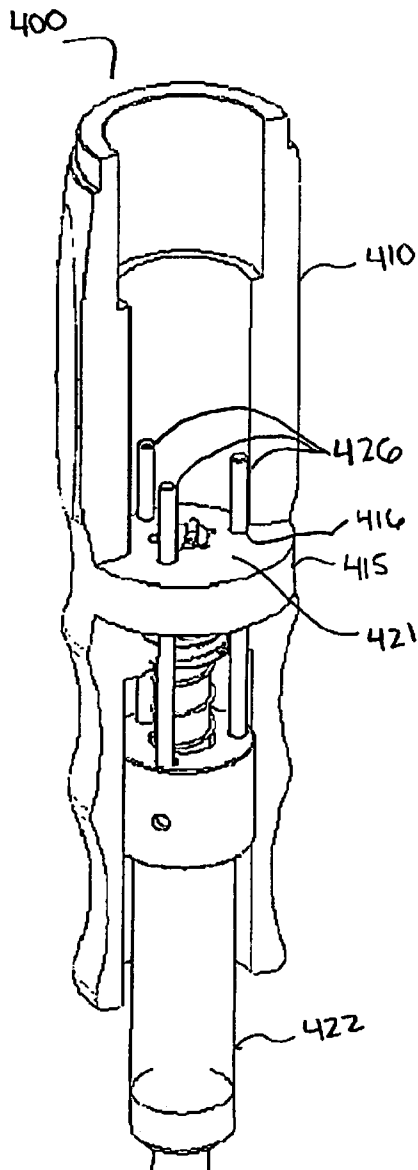

FIG. 10D

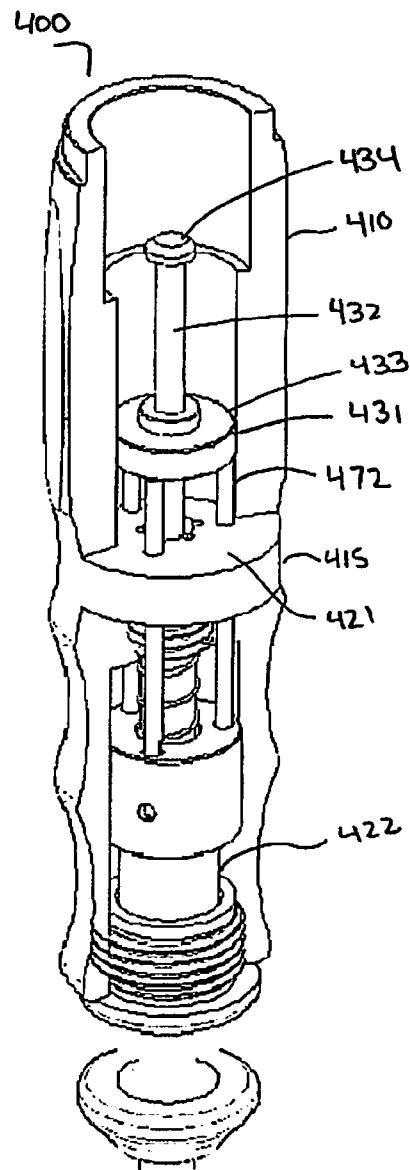

FIG. 10E

40x

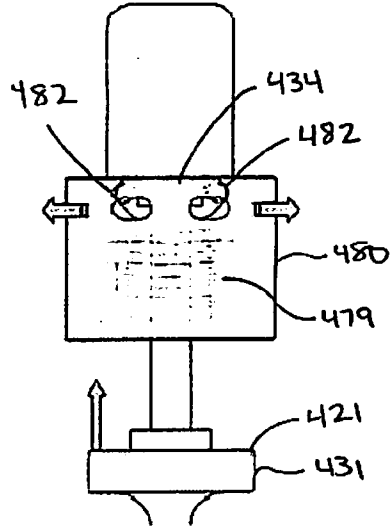
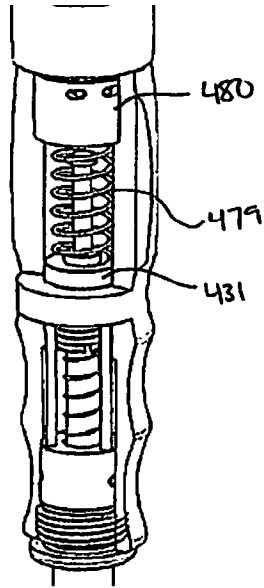

FIG. 10F

FIG. 10G

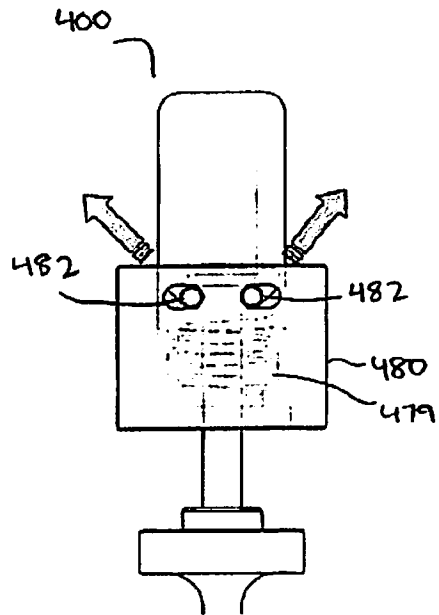
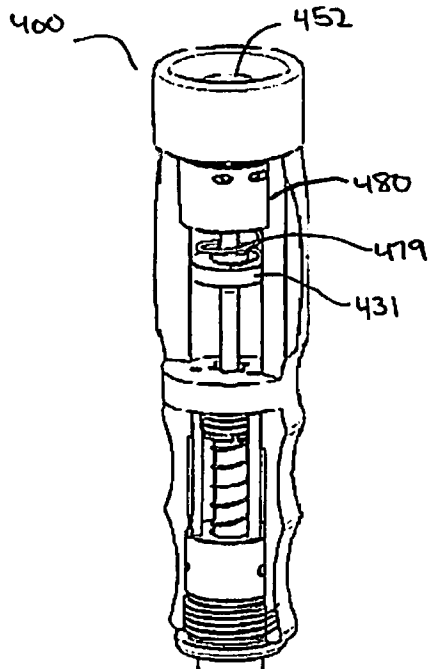

FIG. 10H

FIG. 10I

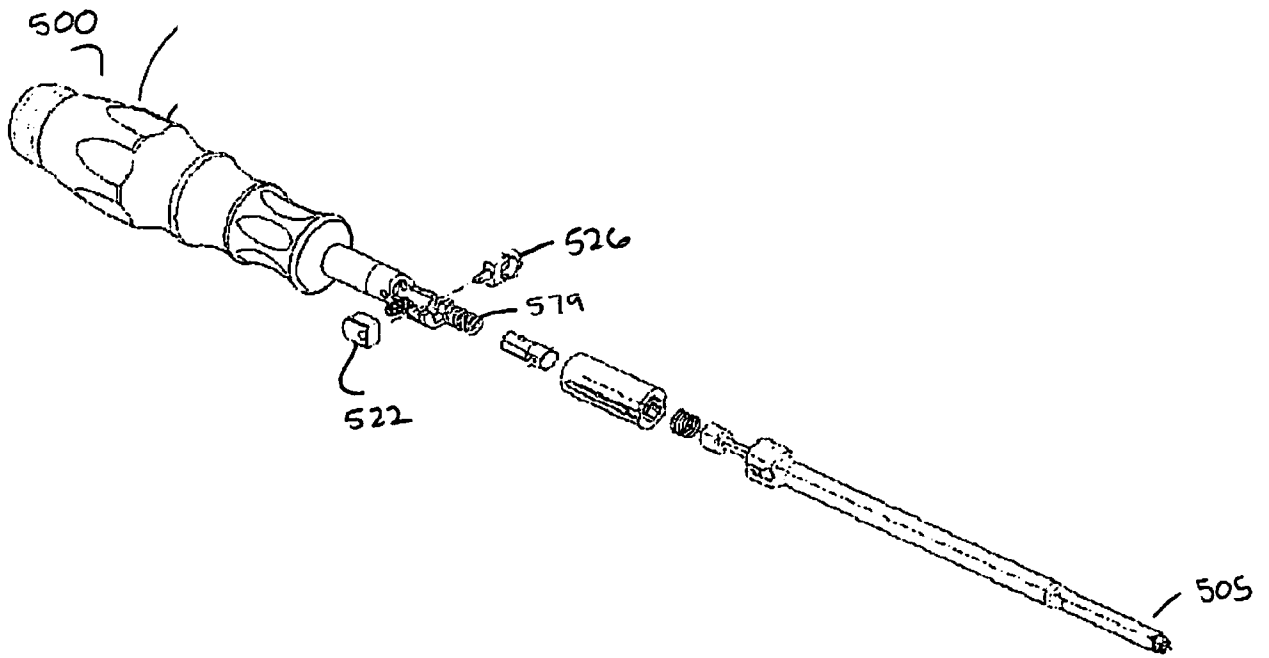

FIG. 11A

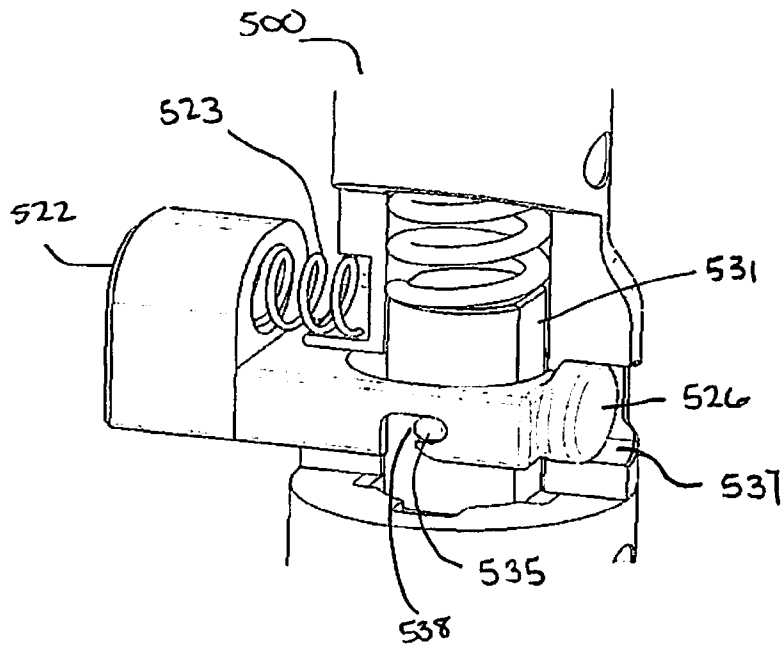

FIG. 11B

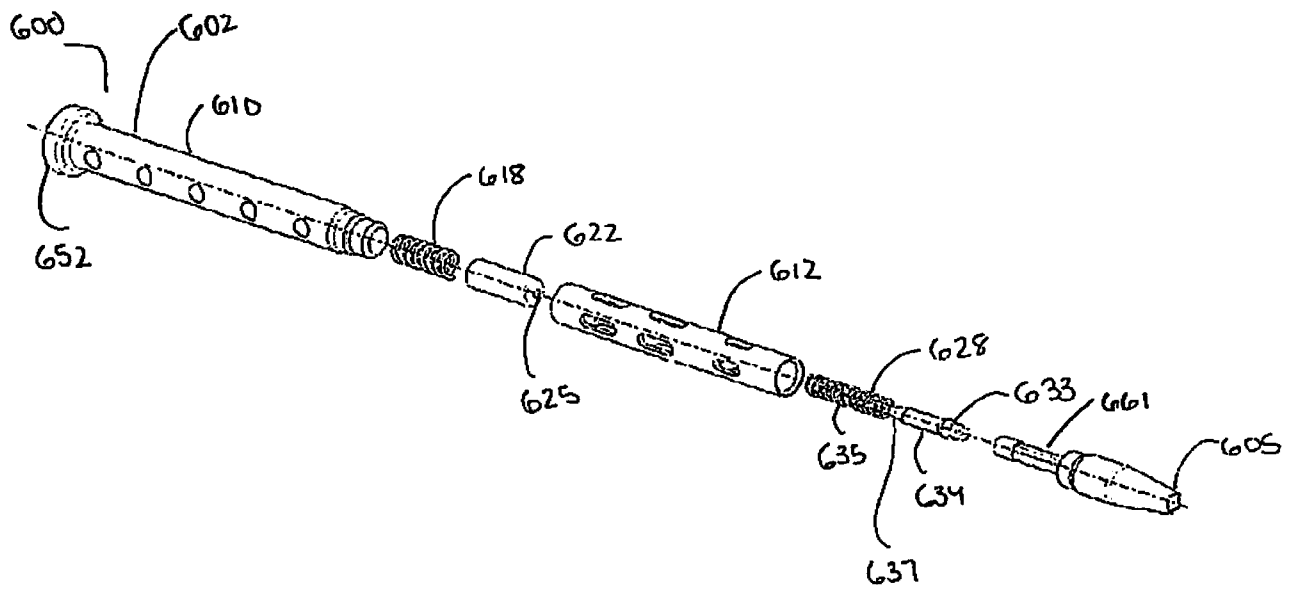

FIG. 12A

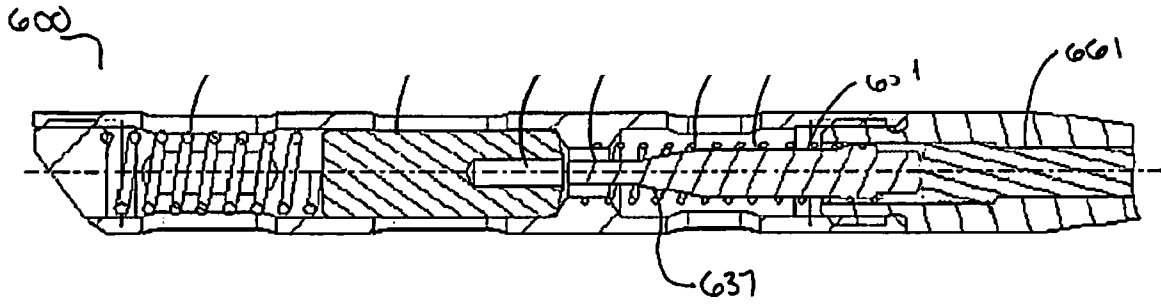

FIG. 12B

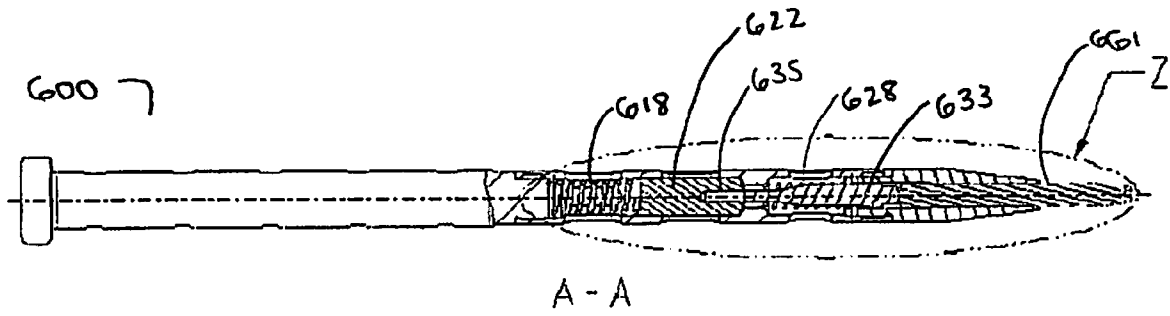

FIG. 12C

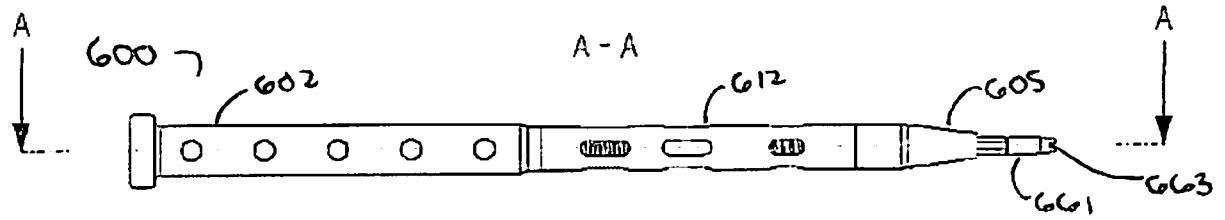

FIG. 12D

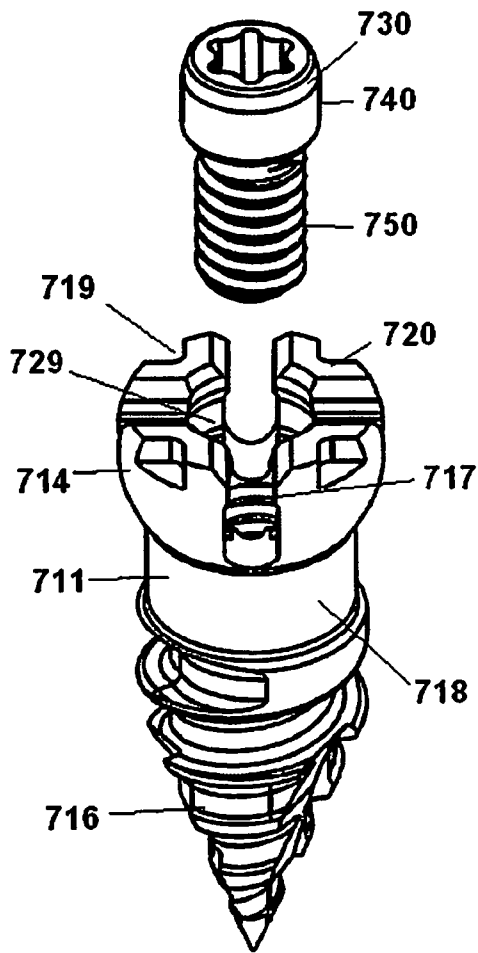

FIG. 13A

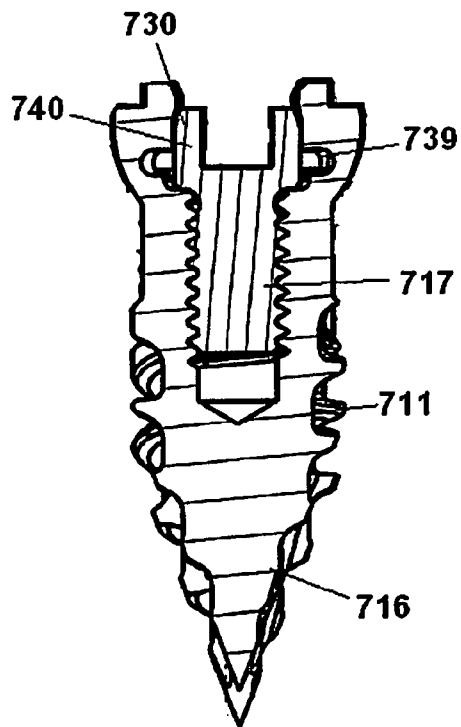

FIG. 13B

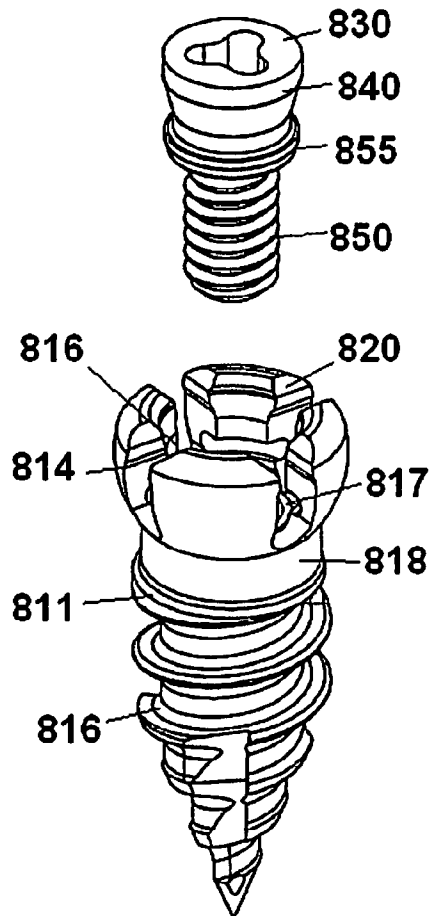

FIG. 14

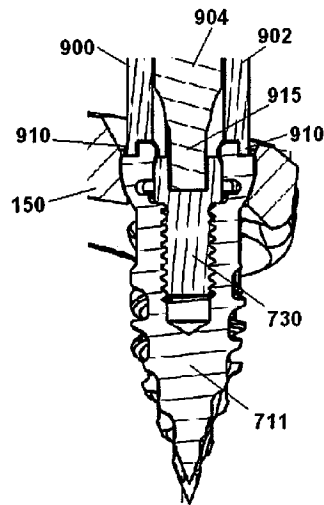

FIG. 15A

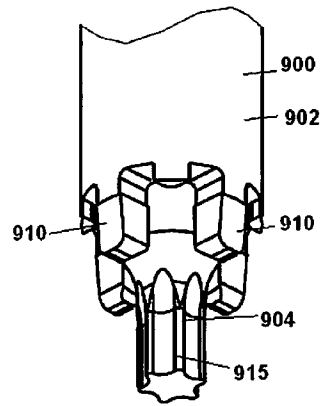

FIG. 15B

INTERNATIONAL SEARCH REPORT

International application No.
PCT/US2014/043569**A. CLASSIFICATION OF SUBJECT MATTER****A61B 17/86(2006.01)i, A61B 17/80(2006.01)i, A61B 17/88(2006.01)i**

According to International Patent Classification (IPC) or to both national classification and IPC

B. FIELDS SEARCHED

Minimum documentation searched (classification system followed by classification symbols)

A61B 17/86; A61F 2/30; A61B 17/80; A61B 17/58; A61B 17/56; A61B 17/88

Documentation searched other than minimum documentation to the extent that such documents are included in the fields searched

Korean utility models and applications for utility models

Japanese utility models and applications for utility models

Electronic data base consulted during the international search (name of data base and, where practicable, search terms used)

eKOMPASS(KIPO internal) & Keywords:orthopedic, plate member, anchor, locking mechanism, resilient quadrants, expand, retract

C. DOCUMENTS CONSIDERED TO BE RELEVANT

Category*	Citation of document, with indication, where appropriate, of the relevant passages	Relevant to claim No.
X	US 2007-0288025 A1 (PEUKERT et al.) 13 December 2007 See abstract; paragraphs [0056]-[0070]; and figures 1-5.	1-20
A	US 2013-0096633 A1 (BLACK et al.) 18 April 2013 See paragraphs [0049]-[0059]; and figures 6A-7C.	1-20
A	US 2012-0303071 A1 (BLACK et al.) 29 November 2012 See paragraphs [0044]-[0057]; and figures 1-6.	1-20
A	US 7048739 B2 (KONIECZYNSKI et al.) 23 May 2006 See column 7, line 34 - column 9, line 57; and figures 1A-1C.	1-20
A	US 2011-0270326 A1 (BLACK et al.) 3 November 2011 See paragraphs [0083]-[0092]; and figures 5A-6B.	1-20
A	US 2006-0167456 A1 (JOHNSTON et al.) 27 July 2006 See paragraphs [0026]-[0032]; and figures 1-10.	1-20

 Further documents are listed in the continuation of Box C. See patent family annex.

* Special categories of cited documents:

"A" document defining the general state of the art which is not considered to be of particular relevance

"E" earlier application or patent but published on or after the international filing date

"L" document which may throw doubts on priority claim(s) or which is cited to establish the publication date of another citation or other special reason (as specified)

"O" document referring to an oral disclosure, use, exhibition or other means

"P" document published prior to the international filing date but later than the priority date claimed

"T" later document published after the international filing date or priority date and not in conflict with the application but cited to understand the principle or theory underlying the invention

"X" document of particular relevance; the claimed invention cannot be considered novel or cannot be considered to involve an inventive step when the document is taken alone

"Y" document of particular relevance; the claimed invention cannot be considered to involve an inventive step when the document is combined with one or more other such documents, such combination being obvious to a person skilled in the art

"&" document member of the same patent family

Date of the actual completion of the international search

13 October 2014 (13.10.2014)

Date of mailing of the international search report

13 October 2014 (13.10.2014)

Name and mailing address of the ISA/KR

International Application Division
Korean Intellectual Property Office
189 Cheongsu-ro, Seo-gu, Daejeon Metropolitan City, 302-701,
Republic of Korea

Facsimile No. +82-42-472-7140

Authorized officer

CHANG, Bong Ho

Telephone No. +82-42-481-3353



INTERNATIONAL SEARCH REPORT

Information on patent family members

International application No.

PCT/US2014/043569

Patent document cited in search report	Publication date	Patent family member(s)	Publication date
US 2007-0288025 A1	13/12/2007	DE 102004050040 A1 EP 1796561 A1 JP 04834670 B2 JP 2008-515498 A US 2011-0251649 A1 US 7988714 B2 US 8398688 B2 WO 2006-040063 A1	20/04/2006 20/06/2007 14/12/2011 15/05/2008 13/10/2011 02/08/2011 19/03/2013 20/04/2006
US 2013-0096633 A1	18/04/2013	EP 2765937 A2 WO 2013-056199 A2	20/08/2014 18/04/2013
US 2012-0303071 A1	29/11/2012	EP 2713920 A1 US 8771324 B2 WO 2012-166685 A1	09/04/2014 08/07/2014 06/12/2012
US 7048739 B2	23/05/2006	US 2004-0127904 A1 US 2006-0241616 A1 US 7651517 B2	01/07/2004 26/10/2006 26/01/2010
US 2011-0270326 A1	03/11/2011	EP 2563251 A2 JP 2013-525008 A US 2014-0142641 A1 US 8647371 B2 WO 2012-012009 A2 WO 2012-012009 A3	06/03/2013 20/06/2013 22/05/2014 11/02/2014 26/01/2012 26/04/2012
US 2006-0167456 A1	27/07/2006	US 7736380 B2 WO 2006-069089 A2 WO 2006-069089 A3	15/06/2010 29/06/2006 02/11/2006