

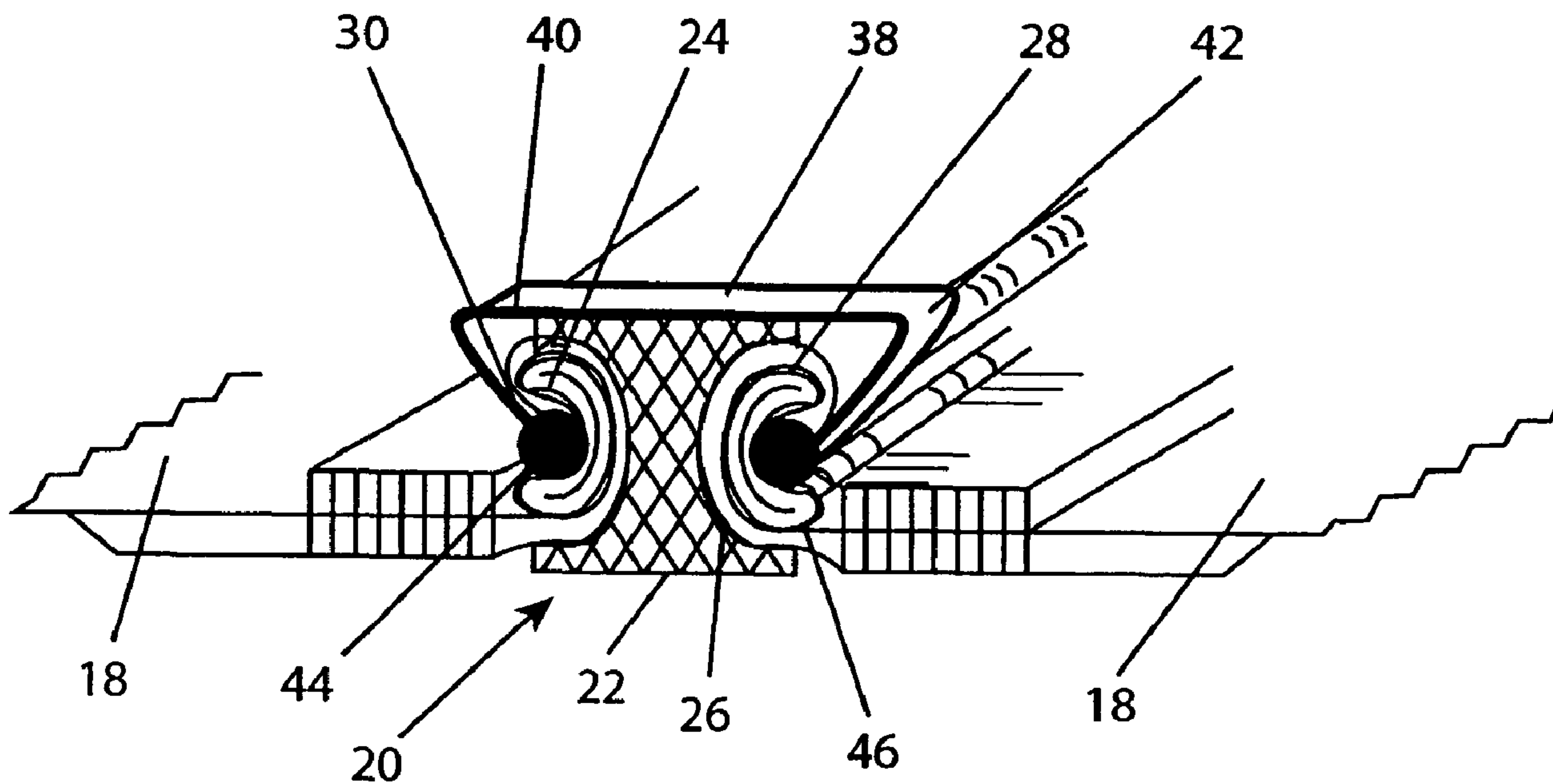

(86) Date de dépôt PCT/PCT Filing Date: 2002/10/25  
 (87) Date publication PCT/PCT Publication Date: 2003/05/08  
 (45) Date de délivrance/Issue Date: 2011/01/25  
 (85) Entrée phase nationale/National Entry: 2004/03/25  
 (86) N° demande PCT/PCT Application No.: US 2002/034299  
 (87) N° publication PCT/PCT Publication No.: 2003/037707  
 (30) Priorité/Priority: 2001/10/30 (US10/016,640)

(51) Cl.Int./Int.Cl. *B63B 35/28* (2006.01)  
 (72) Inventeur/Inventor:  
EAGLES, DANA, US  
 (73) Propriétaire/Owner:  
ALBANY INTERNATIONAL CORP., US  
 (74) Agent: NELLIGAN O'BRIEN PAYNE LLP

(54) Titre : RECIPIENT DE RETENTION DE FLUIDE FLEXIBLE SOUS FORME DE SEGMENT  
 (54) Title: SEGMENT FORMED FLEXIBLE FLUID CONTAINMENT VESSEL



(57) Abrégé/Abstract:

A flexible fluid containment vessel or vessels fabricated out of segments of fabric clamped together for transporting and containing a large volume of fluid, particularly fresh water, having means for joining the segments comprising a first upright member (28) on a surface of one segment (48) along an edge thereof; a second (30) upright member on a surface (18) of a second segment along an edge thereof; aligning said first and second upright members (28, 30), means (22) for sealing a space between said first and second segments, and means (38) for securing said first and second upright members together.

## (12) INTERNATIONAL APPLICATION PUBLISHED UNDER THE PATENT COOPERATION TREATY (PCT)

(19) World Intellectual Property Organization  
International Bureau



(43) International Publication Date  
8 May 2003 (08.05.2003)

PCT

(10) International Publication Number  
**WO 03/037707 A1**

- (51) International Patent Classification<sup>7</sup>: **B63B 35/28**
- (21) International Application Number: PCT/US02/34299
- (22) International Filing Date: 25 October 2002 (25.10.2002)
- (25) Filing Language: English
- (26) Publication Language: English
- (30) Priority Data:  
10/016,640 30 October 2001 (30.10.2001) US
- (71) Applicant: **ALBANY INTERNATIONAL CORP.**  
[US/US]; 1373 Broadway, Albany, NY 12204 (US).
- (81) Designated States (*national*): AE, AG, AL, AM, AT, AU, AZ, BA, BB, BG, BR, BY, BZ, CA, CH, CN, CO, CR, CU, CZ, DE, DK, DM, DZ, EC, EE, ES, FI, GB, GD, GE, GH, GM, HR, HU, ID, IL, IN, IS, JP, KE, KG, KP, KR, KZ, LC, LK, LR, LS, LT, LU, LV, MA, MD, MG, MK, MN, MW, MX, MZ, NO, NZ, OM, PH, PL, PT, RO, RU, SD, SE, SG, SI, SK, SL, TJ, TM, TN, TR, TT, TZ, UA, UG, UZ, VC, VN, YU, ZA, ZM, ZW.
- (84) Designated States (*regional*): ARIPO patent (GH, GM, KE, LS, MW, MZ, SD, SL, SZ, TZ, UG, ZM, ZW), Eurasian patent (AM, AZ, BY, KG, KZ, MD, RU, TJ, TM), European patent (AT, BE, BG, CH, CY, CZ, DE, DK, EE, ES, FI, FR, GB, GR, IE, IT, LU, MC, NL, PT, SE, SK, TR), OAPI patent (BF, BJ, CF, CG, CI, CM, GA, GN, GQ, GW, ML, MR, NE, SN, TD, TG).

**Published:**

— with international search report

For two-letter codes and other abbreviations, refer to the "Guidance Notes on Codes and Abbreviations" appearing at the beginning of each regular issue of the PCT Gazette.

- (72) Inventor: **EAGLES, Dana**; 223 South Main, Sherborn, MA 01770 (US).
- (74) Agent: **SANTUCCI, Ronald, R.**; Frommer Lawrence & Haug, LLP, 745 Fifth Avenue, New York, NY 10151 (US).

(54) Title: SEGMENT FORMED FLEXIBLE FLUID CONTAINMENT VESSEL

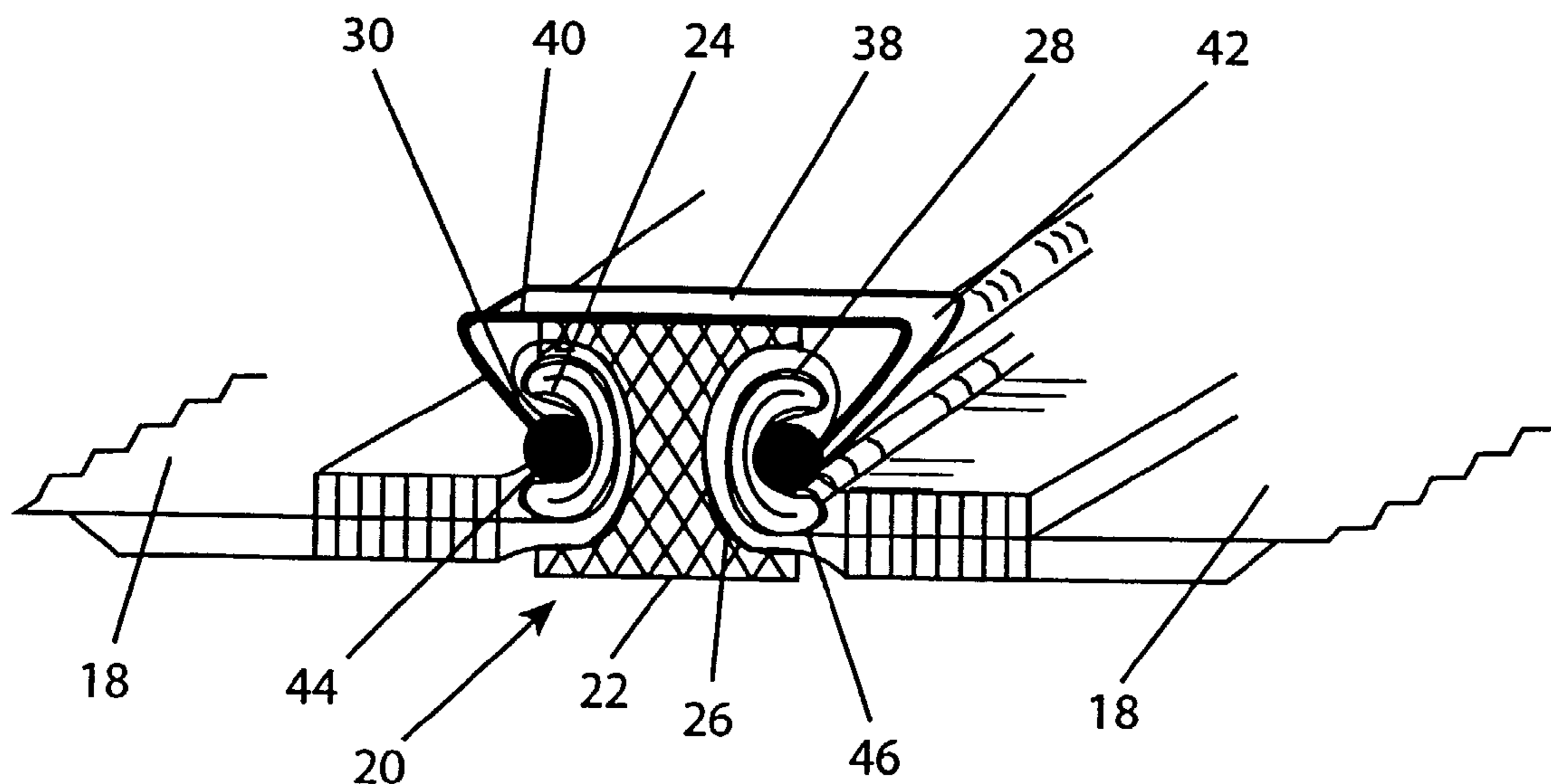

(57) Abstract: A flexible fluid containment vessel or vessels fabricated out of segments of fabric clamped together for transporting and containing a large volume of fluid, particularly fresh water, having means for joining the segments comprising a first upright member (28) on a surface of one segment (48) along an edge thereof; a second (30) upright member on a surface (18) of a second segment along an edge thereof; aligning said first and second upright members (28, 30), means (22) for sealing a space between said first and second segments, and means (38) for securing said first and second upright members together.

WO 03/037707 A1

## SEGMENT FORMED FLEXIBLE FLUID CONTAINMENT VESSEL

### Field of the Invention

5 The present invention relates to a flexible fluid containment vessel (sometimes hereinafter referred to as "FFCV") for transporting and containing a large volume of fluid, particularly fluid having a density less than that of salt water, more particularly, fresh water, and the method of making the same.

### 10 Background of the Invention

The use of flexible containers for the containment and transportation of cargo, particularly fluid or liquid cargo, is well known. It is well known to use containers to transport fluids in water, particularly, salt water.

15 If the cargo is fluid or a fluidized solid that has a density less than salt water, there is no need to use rigid bulk barges, tankers or containment vessels. Rather, flexible containment vessels may be used and towed or pushed from one location to another. Such flexible vessels have obvious advantages over rigid vessels. Moreover, flexible vessels, if constructed appropriately, allow themselves to be rolled up or folded after the cargo has  
20 been removed and stored for a return trip.

Throughout the world there are many areas which are in critical need of fresh water. Fresh water is such a commodity that harvesting of the ice cap and icebergs is rapidly emerging as a large business. However, wherever the fresh water is obtained, economical transportation thereof to the intended  
25 destination is a concern.

For example, currently an icecap harvester intends to use tankers having 150,000 ton capacity to transport fresh water. Obviously, this involves, not only the cost in using such a transport vehicle, but the added expense of its return trip, unloaded, to pick up fresh cargo. Flexible  
30 container vessels, when emptied can be collapsed and stored on, for example,

the tugboat that pulled it to the unloading point, reducing the expense in this regard.

Even with such an advantage, economy dictates that the volume being transported in the flexible container vessel be sufficient to overcome the expense of transportation. Accordingly, larger and larger flexible containers are being developed. However, technical problems with regard to such containers persist even though developments over the years have occurred. In this regard, improvements in flexible containment vessels or barges have been taught in U.S. Patents 2,997,973; 2,998,973; 3,001,501; 3,056,373; and 3,167,103. The intended uses for flexible containment vessels is usually for transporting or storing liquids or fluidisable solids which have a specific gravity less than that of salt water.

The density of salt water as compared to the density of the liquid or fluidisable solids reflects the fact that the cargo provides buoyancy for the flexible transport bag when a partially or completely filled bag is placed and towed in salt water. This buoyancy of the cargo provides flotation for the container and facilitates the shipment of the cargo from one seaport to another.

In U.S. Patent 2,997,973, there is disclosed a vessel comprising a closed tube of flexible material, such as a natural or synthetic rubber impregnated fabric, which has a streamlined nose adapted to be connected to towing means, and one or more pipes communicating with the interior of the vessel such as to permit filling and emptying of the vessel. The buoyancy is supplied by the liquid contents of the vessel and its shape depends on the degree to which it is filled. This patent goes on to suggest that the flexible transport bag can be made from a single fabric woven as a tube. It does not teach, however, how this would be accomplished with a tube of such magnitude. Apparently, such a structure would deal with the problem of seams. Seams are commonly found in commercial flexible transport bags, since the bags are typically made in a patch work manner with stitching or other means of connecting the patches of water proof material together. See

e.g. U.S. Patent 3,779,196. Seams are, however, known to be a source of bag failure when the bag is repeatedly subjected to high loads. Seam failure can obviously be avoided in a seamless structure. However, since a seamed structure is an alternative to a simple woven fabric and would have different advantages thereto, particularly in the fabrication thereof, it would be desirable if one could create a seamed tube that was not prone to failure at the seams.

In this regard, U.S. Patent No. 5,360,656 entitled "Press Felt and Method of Manufacture", which issued November 1, 1994 and is commonly assigned, discloses a base fabric of a press felt that is fabricated from spirally wound fabric strips. The fabric strip of yarn material, preferably being a flat-woven fabric strip, has longitudinal threads which in the final base fabric make an angle in what would be the machine direction of the press felt.

During the manufacture of the base fabric, the fabric strip of yarn material is wound or placed spirally, preferably over at least two rolls having parallel axes. Thus, the length of fabric will be determined by the length of each spiral turn of the fabric strip of yarn material and its width determined by the number of spiral turns.

The number of spiral turns over the total width of the base fabric may vary. The adjoining portions of the longitudinal edges of the spirally-wound fabric strip are so arranged that the joints or transitions between the spiral turns can be joined in a number of ways.

An edge joint can be achieved, e.g. by sewing, melting, and welding (for instance, ultrasonic welding as set forth in U.S. Patent No. 5,713,399 entitled "Ultrasonic Seaming of Abutting Strips for Paper Machine Clothing" which issued February 3, 1998 and is commonly assigned) of non-woven material or of non-woven material with melting fibers. The edge joint can also be obtained by providing the fabric strip of yarn material along its two longitudinal edges with seam loops of a known type, which can be joined by means of one or

more seam threads. Such seam loops may for instance be formed directly of the weft threads, if the fabric strip is flat-woven.

While that patent relates to creating a base fabric for a press felt such technology may have application in creating a sufficiently strong tubular structure for a transport container. Moreover, with the intended use being a transport container, rather than a press fabric where a smooth transition between fabric strips is desired, this is not a particular concern and different joining methods (overlapping and sewing, bonding, stapling, etc.) are possible. Other types of joining may be apparent to one skilled in the art.

It should be noted that U.S. Patent No. 5,902,070 entitled "Geotextile Container and Method of Producing Same" issued May 11, 1999 and assigned to Bradley Industrial Textiles, Inc. does disclose a helically formed container. Such a container is, however, intended to contain fill and to be stationary rather than a transport container.

Accordingly, while a FFCV formed in segments is desirable, whether formed spirally or in a patch work, avoidance of failure at the seams is a critical necessity.

#### Summary of the Invention

It is therefore a principal object of the invention to provide for an FFCV which is made in segments which are joined together in a secure fashion.

It is a further object of the invention to provide for an FFCV wherein the segments which make it up are capable of being attached together in a convenient manner.

A yet further object of the invention is to provide for joining segments together by a means wherein only one side of the FFCV, preferably the outside, is where joining together takes place.

Accordingly, the present invention is directed towards providing a means for joining segments of fabric together to create an FFCV. In this regard, the present invention provides for a clamping mechanism to secure

adjacent lengths of fabric together. The clamping mechanism entails creating a C-shaped portion along the edge of the fabric segment and placing the C-shaped portion into and/or abutting one side of, for example, a rigid member or an adjacent so formed C-shaped member on an adjacent fabric segment and then a clamp is secured about the structure thereby clamping the segments together. Glue or a sealing compound may also be used between the portions as an alternative to the rigid member or in conjunction therewith. This would be repeated so as to secure all the segments making up the tube which forms the FFCV.

10

#### Brief Description of the Drawings

Thus by the present invention, its objects and advantages will be realized the description of which should be taken in conjunction with the drawings wherein:

15

Figure 1 is a somewhat general perspective view of a prior art FFCV which is cylindrical having a pointed bow or nose;

Figure 2 is a somewhat general perspective view of an FFCV which is formed in segments, incorporating the teachings of the present invention;

20

Figure 3 is a side sectional view of the clamping mechanism incorporating the teachings of the present invention; and

Figures 4A-4C are side sectional views of the formation of the C-shaped section located at the edge of the segment prior to clamping.

#### Detailed Description of the Preferred Embodiment

25

The proposed FFCV 10 is intended to be constructed of an impermeable textile tube. The tube's configuration may vary. For example, as shown in Figure 2, it would comprise a tube 12 having a substantially uniform diameter (perimeter) and sealed on each end 14 and 16. The respective ends 14 and 16 may be closed, pinched, and sealed in any number of ways. A means for loading and unloading cargo would be provided. The resulting impermeable structure which is fabricated out of segments or

30

sections of material 18 will be flexible enough to be folded or wound up for transportation and storage.

In designing the FFCV to withstand the loads placed thereon, certain factors should be considered. In this regard, in U.S. Patent No. 6,860,218  
5 entitled "Flexible Fluid Containment Vessel" such factors are set forth in detail, along with possible materials for the fabric making up the segments 18, their construction and possible coatings and methodology to apply to it to render the fabric impermeable, in addition to other features which may be desirable with regard to the FFCV.

10 Accordingly, further discussion thereof will not be repeated herein; rather reference is made to said patent. Also, the present device may have application with regard to the spiral formed FFCV as disclosed in U.S. Patent No. 6,675,734 entitled "Spiral Formed Flexible Fluid Containment Vessel". While there is discussed therein means and methods for joining the wound  
15 strips together to form an FFCV, the present device may provide an alternative thereto for all or part of the joining process. For example, in high load portions of the FFCV, typically the front and rear, one methodology may be used. For less stressful locations another methodology may be used.

In addition, reference is made to U.S. Patent No. 6,739,274 entitled  
20 "End Portions for a Flexible Fluid Containment Vessel and a Method of Making the Same" which relates to possible construction of the end portions of the FFCV and U.S. Patent No. 7,308,862 entitled "Coating for a Flexible Fluid Containment Vessel and a Method of Making the Same" which discloses additional construction for the fabric for the segment in addition to possible  
25 coatings therefor.

With all of this in mind, we turn now more particularly to Figures 3 through 4C where like elements are similarly numbered. In this regard, Figure 3 shows a cross section view of the clamping mechanism or device 20

joining two segments 18 of fabric. As aforesaid, the fabric segments 18 can be that of a patchwork to create the FFCV, wound strip or of other configuration suitable for the purpose.

5 One of the advantages of the particular configuration is that it can be affixed and serviced, if necessary, from only one side of the FFCV, preferably the outside or seawater side.

10 The clamping device 20 comprises an elongated member 22 which is shown as being I-shaped but may also be L-shaped or any other shape suitable for the purpose. Member 22 may be made of a flexible resilient material which allows it to bend as is necessary when the FFCV is folded or wound up when emptied. Member 22 includes opposite C-shaped receiving portions 24 and 26 for matingly receiving respective C-shaped members 28 and 30, the formation of which will be discussed.

15 In this regard, the C-shaped members 28 and 30 may be made separate from the fabric segments 18 and attached or from the fabric segments themselves, which would depend upon the fabric structure and composition. For example, if the fabric's structure allowed it to be gathered at its end to form a C-shaped member, such a member so formed could be retained in shape by gluing, sewing, thermal bonding, coating or any other  
20 means suitable for the purpose. If the fabric does not lend itself to such gather, then the C-shaped member can be made separately and attached to the body of the fabric. In this regard, reference is now made to Figures 4A-4C.

25 In these figures, the C-shaped members 28 and 30 are fabricated and secured to the fabric body in the following manner. A braided or woven tube 32 of fabric is formed for the length of the segment 18. The tube 32 is then folded inwardly as shown in Figure 4B to create the C-shaped members. It may be fixed in this shaped by way of gluing, sewing or any other means suitable for the purpose. After being so formed, the C-shaped member may  
30 be rendered impermeable to fluid by, for example, coating or by other means. A C-shaped member is then affixed to the end of the segment 18 by

wrapping the end portion 34 thereof about the C-shaped member and sewing or gluing overlap 36 thereby fixedly securing it thereto. This will provide a flexible structure allowing it to be rolled up on a reel or folded for storage and transportation.

5 Of course other means of creating the C-shaped member on the end of the segments 18 will be apparent to those skilled in the art. Also, while a C-shaped member is shown and described, other shaped members suitable for the purpose should be apparent to those skilled in the art.

10 Returning now to Figure 3, respective segments 18 having C-shaped members 28 and 30 can now be joined together by placing said members into opposite sides of the I-shaped member 22. A U-shaped clamp 38 is then spring loaded, snapped or crimped thereover. In this regard, legs 40 and 42 of clamp 38 are provided with enlarged portions 44 and 46 which are sized to fit within the C-shaped members 28 and 30. The clamp 38 secures the two  
15 segments together and creates a seal as between the C-shaped members 28 and 30 and the I-shaped member 22. If necessary, a sealing glue or coating can also be used therebetween or an alternative to using a rigid member 22 all together.

20 Note, the clamp 38 may be made of metal, composite or any other material that allows for effective clamping of the segments. Also, the length of the clamp 38 used should be sufficient for effective clamping but should not be so sized so as to interfere with the reeling up or folding of the FFCV.

25 In addition, clamping together could be effected by a rope sewn along the C-shaped members by way of a number of sewing means and techniques as will be apparent to those skilled in the art. Also, the C-shaped members themselves can be sewn together with an appropriate sealing therebetween.

30 An FFCV formed of such segments has obvious attendant advantages. The fabrication of segments rather than a seamless structure allows them to be flat woven of various lengths and widths. For example, one of the dimensions of the segment can be equal to the circumference of the FFCV and formed into a tubular structure. The variations are endless. It

also allows them to be rendered impermeable prior to joining them together, since the segments can be pre-coated. Also, to ensure a leak free seal, it may be produced either by adding additional sealant to the surface in the area of the overlap 34 after attaching the C-shaped members, or using a bonding process that results in sealed bond at the overlap 34 such as a curable polymeric sealant (an adhesive) such as a curable polyurethane. For example, an ultrasonic bonding or thermal bonding process (see e.g. U.S. Patent No. 5,713,399) could be used with a thermoplastic coating to result in a leak free area. If the fabric segments were not pre-coated, or if it was desired to coat the structure after fabrication, appropriate methods of accomplishing the same are set forth in the aforesaid patent application.

As part of the coating process there is envisioned the use of a foamed coating on the inside or outside or both surfaces of the fabric segments. A foamed coating would provide buoyancy to the FFCV, especially an empty FFCV. An FFCV constructed from materials such as, for example, nylon, polyester and rubber would have a density greater than salt water. As a result the empty FFCV or empty portions of the large FFCV would sink. This sinking action could result in higher stresses on the FFCV and could lead to significant difficulties in handling the FFCV during filling and emptying of the FFCV. The use of a foam coating provides an alternative or additional means to provide buoyancy to the FFCV.

Also, in view of the closed nature of the FFCV, if it is intended to transport fresh water, as part of the coating process of the inside thereof, it may provide for a coating which includes a germicide or a fungicide so as to prevent the occurrence of bacteria or mold or other contaminants.

In addition, since sunlight also has a degradation effect on fabric, the FFCV may include as part of its coating, or the fiber used to make up the fabric segments, a UV protecting ingredient in this regard.

Although a preferred embodiment has been disclosed and described in detail herein, its scope should not be limited thereby; rather its scope should be determined by that of the appended claims.

What is claimed is:

1. A flexible fluid containment vessel for the transportation of cargo comprising a fluid or fluidisable material, said vessel comprising:
  - an elongated flexible tubular structure;
  - 5 said structure having an inside and an outside characterized in that said elongated tubular structure has a circumference comprised of at least a first fabric segment and a second fabric segment, each fabric segment having an inside, an outside and a width which is smaller than a width of the tubular structure and the segments being joined circumferentially to one another;
  - 10 means for rendering said tubular structure impervious;
  - said tubular structure having a front end and a rear end;
  - means for filling and emptying said vessel of cargo;
  - means for joining said segments together;
  - said means for joining comprising a first upright member on a surface of said first
  - 15 segment along an edge thereof; a second upright member on a surface of said second segment along an edge thereof; wherein said first and second upright members are aligned, means for sealing a space between said first and second segments and means for securing said first and second upright members together; and wherein said means for securing said first and second upright members is only affixed either on said inside or on
  - 20 said outside of said first and second segments.
2. A vessel in accordance with claim 1 wherein said upright members are generally C-shaped and said means for sealing a space includes a means having respective complimentary shaped portions to receive said C-shape.
- 25
3. A vessel in accordance with claim 1 wherein said means for sealing a space has generally an I-shape.

4. A vessel in accordance with claim 1 wherein said clamping means comprises a generally U-shaped clamp which maintains said C-shape members in a clamping arrangement with each other and the I-shaped sealing means therebetween.
5. A vessel in accordance with claim 2 wherein said upright members  
5 are formed from the edge of the segments.
6. A vessel in accordance with claim 2 wherein said upright members are fixedly secured to the edge of the segments.
- 10 7. A vessel in accordance with claim 6 wherein said upright members are maintained within an overlap formed from the edge of the segments.
8. A vessel in accordance with claim 7 wherein said overlap is sewn or glued to the surface of the segment.  
15
9. A vessel in accordance with claim 1 wherein a length of said segment is equal to that of the circumference of the tubular structure.
10. A vessel in accordance with claim 1 wherein said means for securing  
20 said members together includes stitching said members together.
11. A vessel in accordance with claim 10 which further includes rope as part of the stitching.
- 25 12. A method of joining at least two segments of material together comprising the steps of:
- providing at least two segments of material each having a surface and an edge;
  - creating respective upright members at the respective edges of the  
30 segments;

Application No. 2,460,271

Our Docket No. 17648-39

aligning said respective upright members and providing a sealing means therebetween; and

clamping or affixing said respective upright members together.

5 13. The method in accordance with claim 12 wherein said segments comprise fabric.

14. The method in accordance with claim 13 wherein said upright members are created in generally a C-shape.

10

15. The method in accordance with claim 14 wherein said sealing means is generally I-shaped.

16. The method in accordance with claim 15 wherein said clamping is  
15 provided by a generally U-shaped clamp which clamps the C-shaped members to each other with the I-shaped sealing means therebetween.

17. The method in accordance with claim 13 wherein said upright members are formed from the edge of the segments.

20

18. The method in accordance with claim 13 wherein said upright members are formed separately and fixedly secured to the edge of the segments.

25 19. The method in accordance with claim 18 wherein said upright members are formed out of fabric and are generally C-shaped and are fixedly secured to the edge of the segments.

30 20. The method in accordance with claim 19 wherein said C-shaped members are maintained within an overlap formed from the edge of the segments.

Application No. 2,460,271

Our Docket No. 17648-39

21. The method in accordance with claim 20 wherein said overlap is sewn or glued to the surface of the segments.

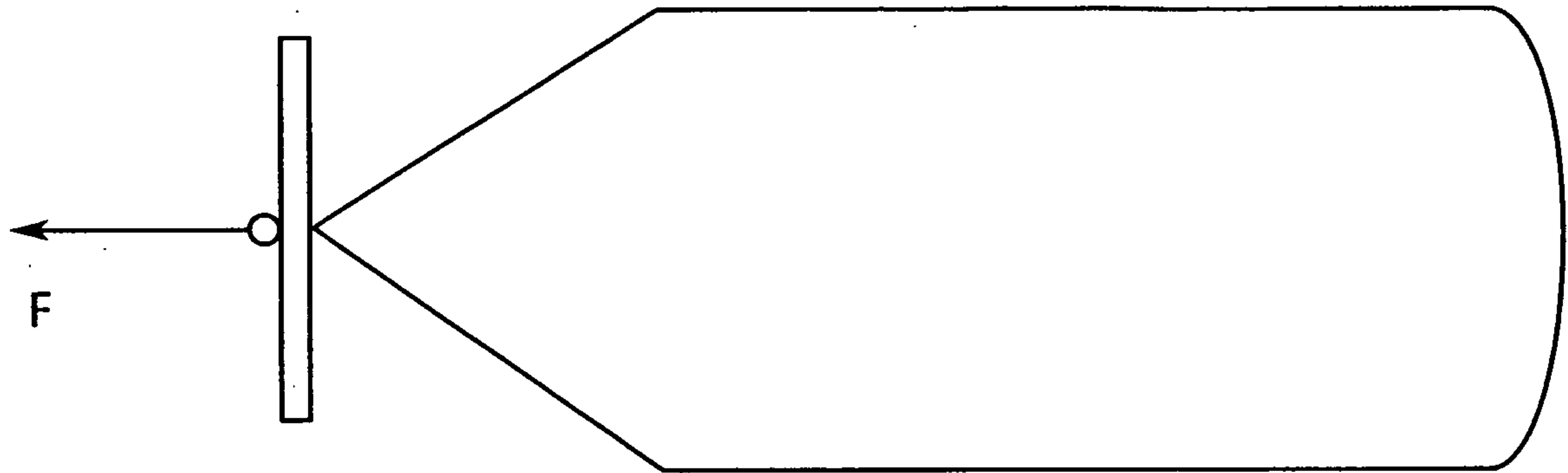

FIG. 1  
(PRIOR ART)

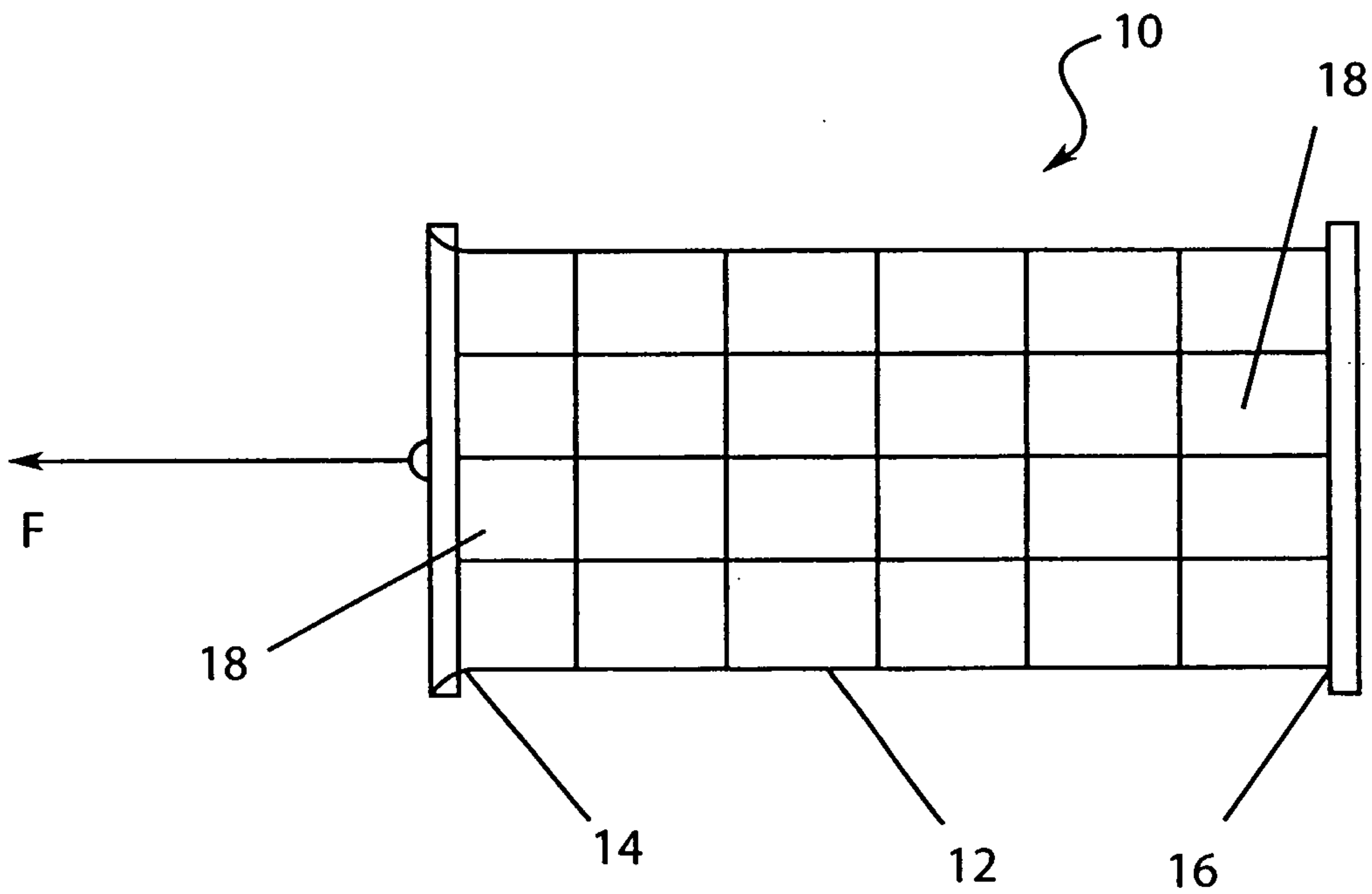

FIG. 2

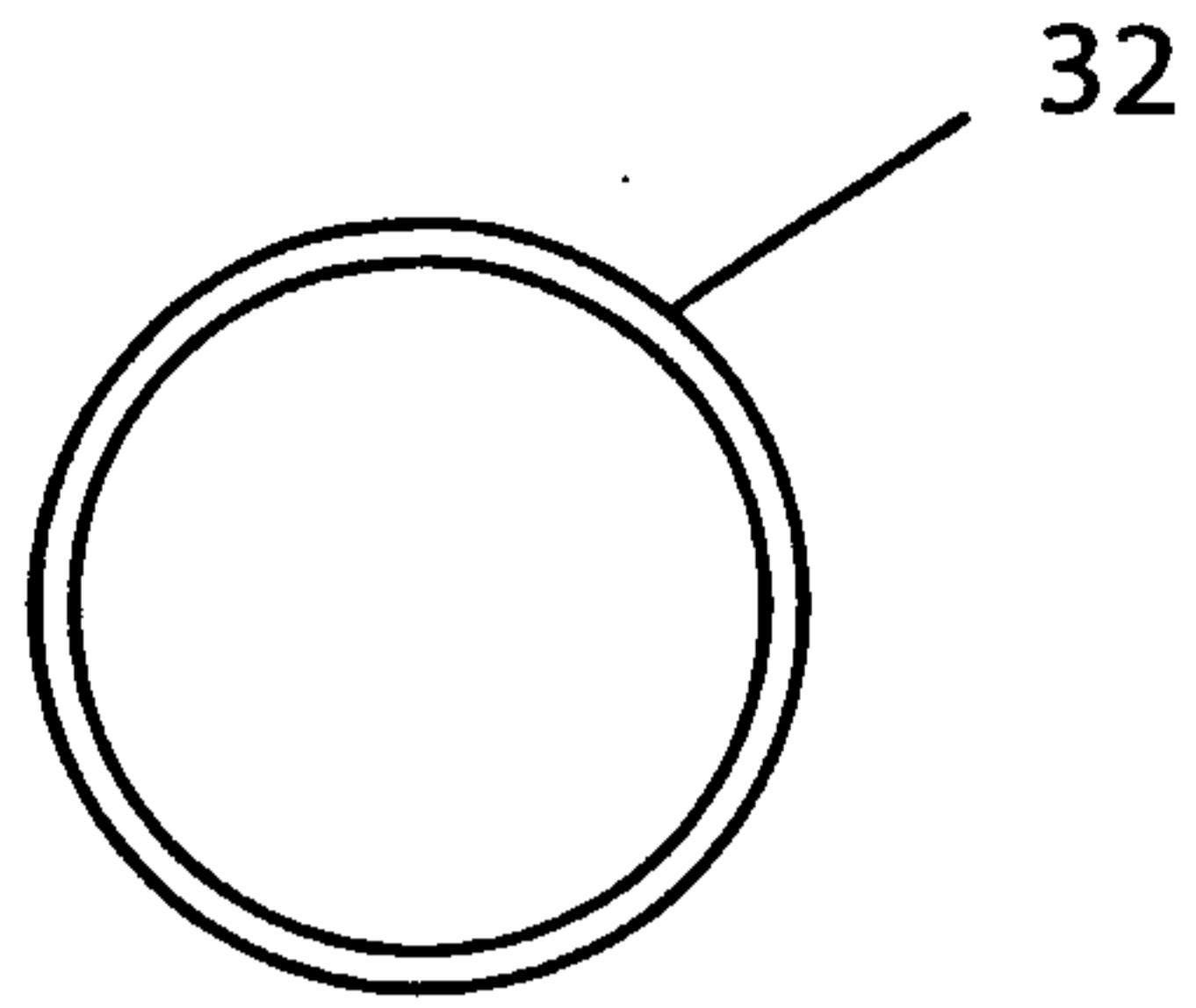

FIG. 4A

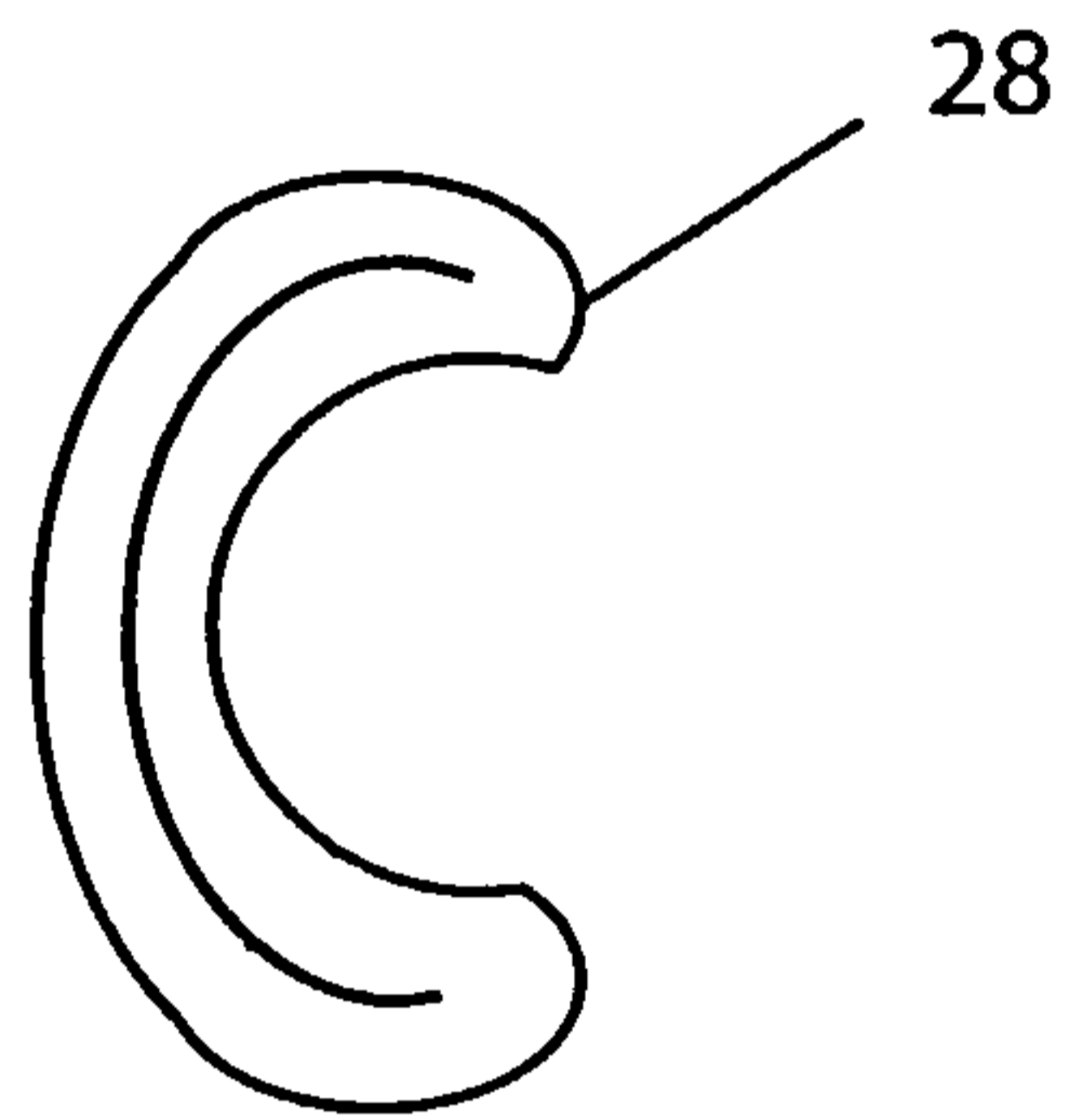

FIG. 4B

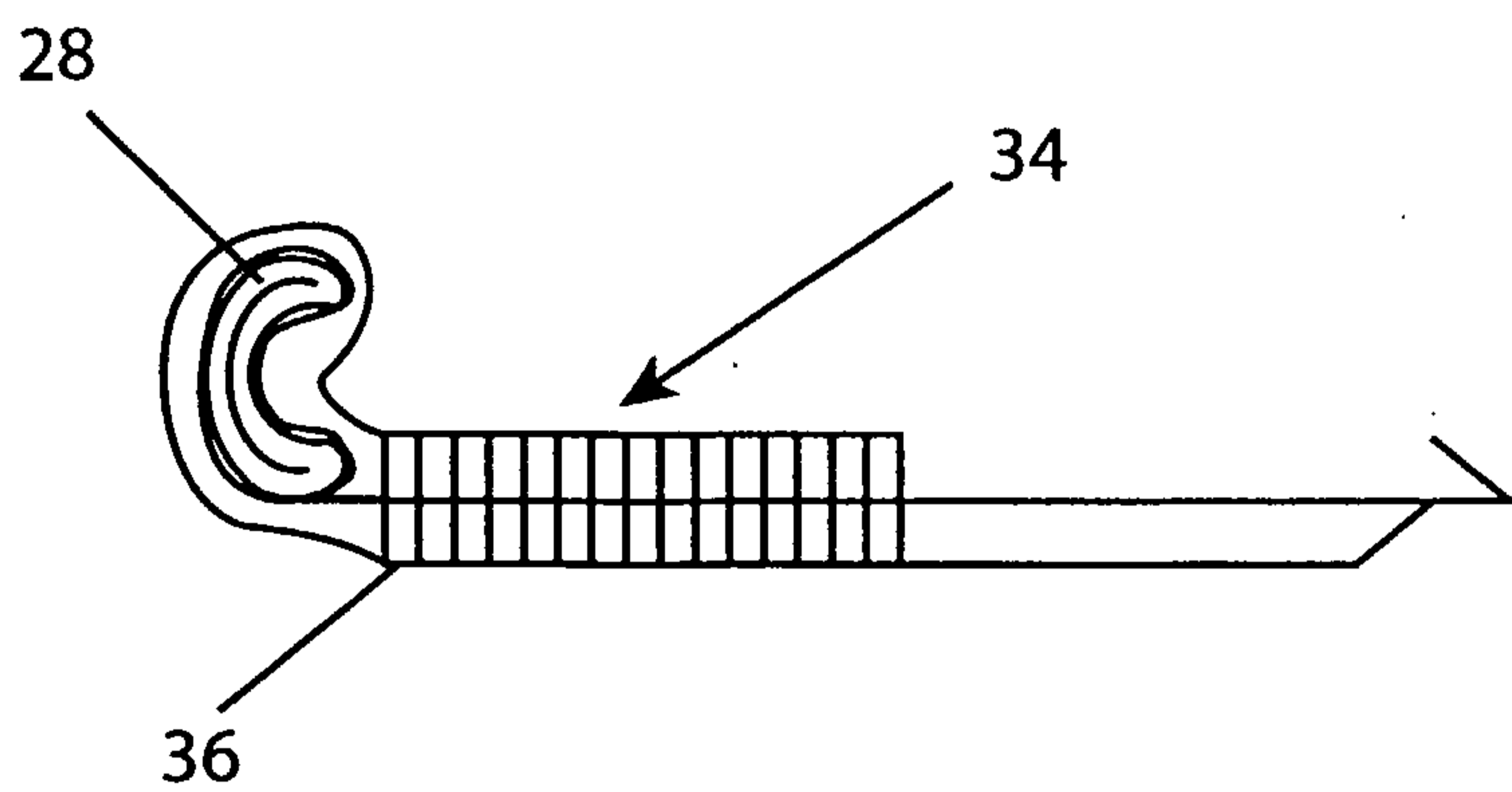

FIG. 4C

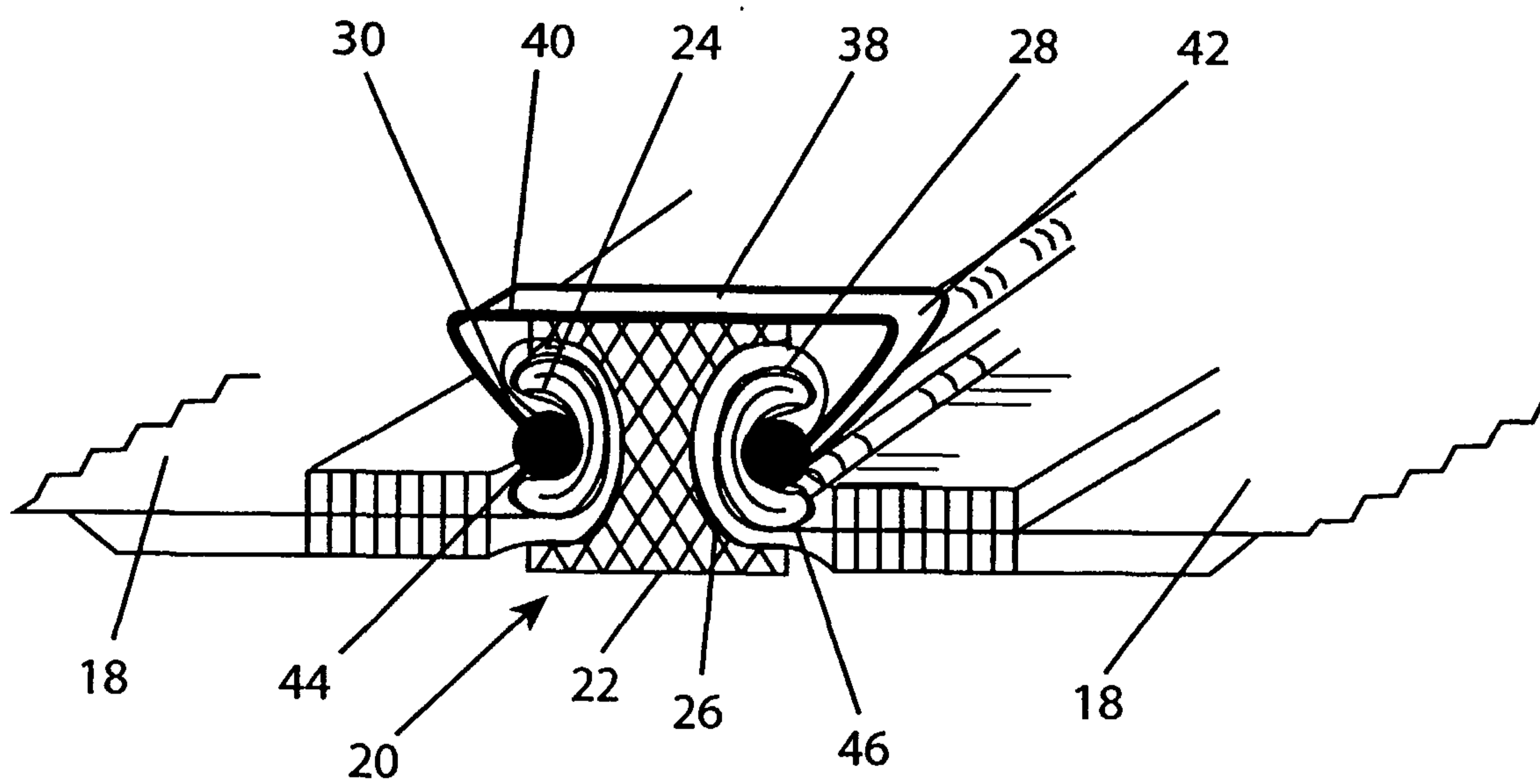

FIG. 3

