

F. E. THOMPSON.  
WEIGHING MACHINE.

No. 548,855.

Patented Oct. 29, 1895.

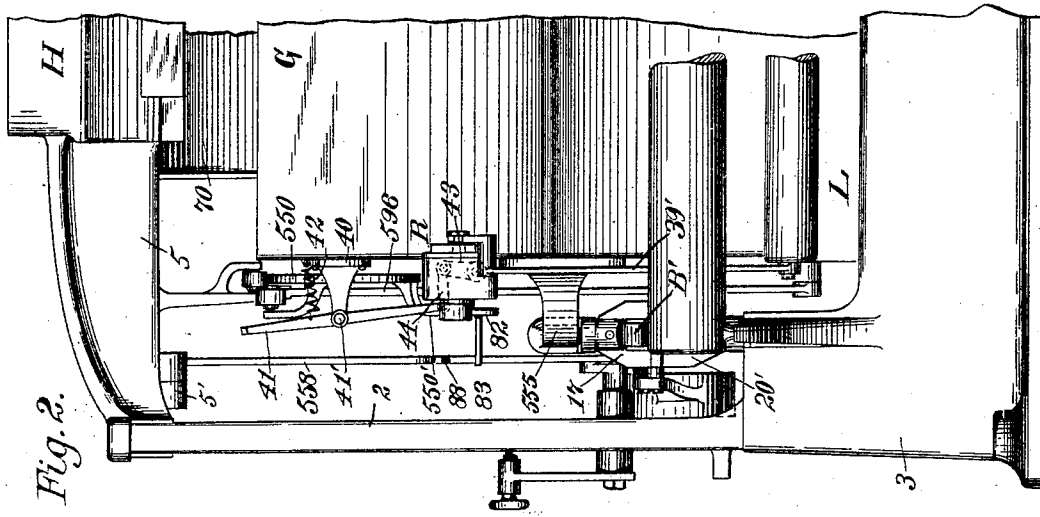

Fig. 2.

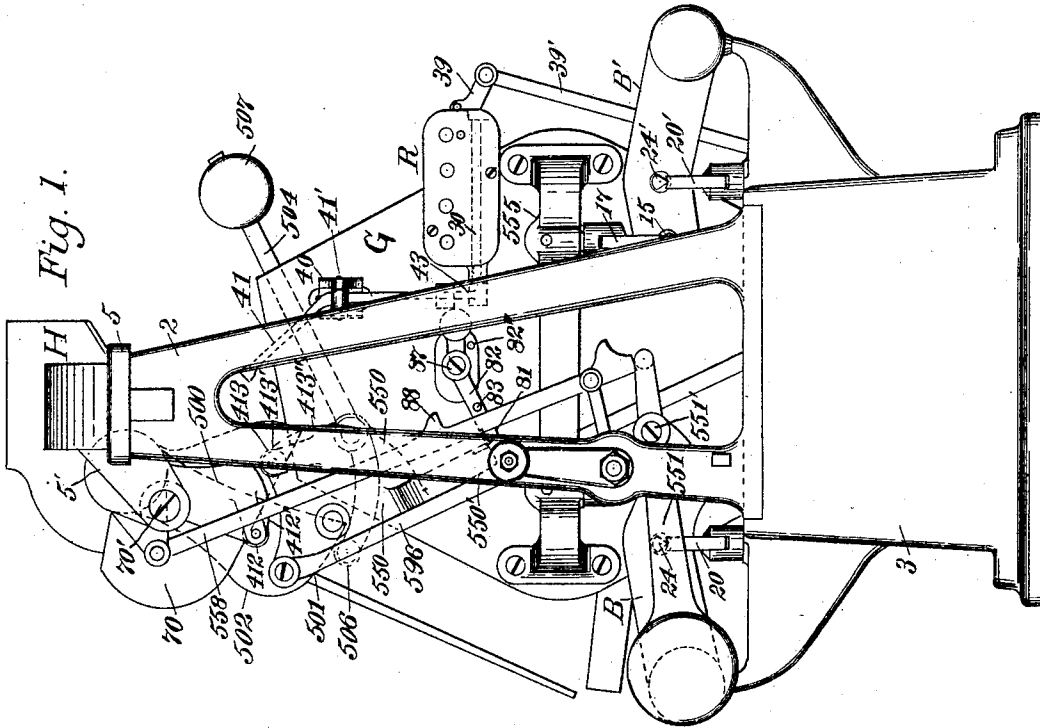

Fig. 1.

Witnesses:  
*R. W. Pittman*  
*Fred. J. Dole.*

Inventor:  
*Frank E. Thompson*  
 By his Attorney  
*F. H. Richards.*



# UNITED STATES PATENT OFFICE.

FRANK E. THOMPSON, OF HARTFORD, CONNECTICUT, ASSIGNOR TO THE PRATT & WHITNEY COMPANY, OF SAME PLACE.

## WEIGHING-MACHINE.

SPECIFICATION forming part of Letters Patent No. 548,855, dated October 29, 1895.

Application filed August 6, 1895. Serial No. 558,379. (No model.)

*To all whom it may concern:*

Be it known that I, FRANK E. THOMPSON, a citizen of the United States, residing at Hartford, in the county of Hartford and State of Connecticut, have invented certain new and useful Improvements in Weighing-Machines, of which the following is a specification.

This invention relates to weighing-machines, and especially to the load-registering mechanism thereof, the object being to provide an improved apparatus or mechanism operable, in connection with a stop-register, for automatically stopping the operation of the weighing-machine when this has delivered a predetermined number of bucket-loads. In the mechanism herein shown and described a valve-movement-limiting latch is provided, and the shiftable member of the stop-register is co-operative with this latch, which has an effective movement into position for holding the valve in a closed position, against which movement the latch will be held while the shiftable member of the stop-register is in the normal position thereof.

In the drawings accompanying and forming part of this specification, Figure 1 is a right-hand end elevation of a weighing-machine embodying my present improvements and illustrating the valve in the open position thereof. Fig. 2 is a front elevation of the machine, showing the parts in substantially the same positions they are shown occupying in Fig. 1. Fig. 3 is a view similar to Fig. 1 and illustrates the valve closed and held in such closed position. Fig. 4 is a view similar to Fig. 2, showing the parts in substantially the same positions they are illustrated occupying in Fig. 3. Fig. 5 is a detail view illustrating a stop-register, with the front or face plate removed to better illustrate the interior parts thereof.

Similar characters designate like parts in all the figures of the drawings.

For convenience the present improvements are shown embodied in a weighing-machine of the "single-bucket" type similar to that shown and described in the concurrently-pending application of Francis H. Richards, Serial No. 545,878, filed April 16, 1895, to which I refer by permission, and that machine will be described briefly, but with suf-

ficient particularity to clearly illustrate the nature and operation of such improvements.

The framework for carrying the operative parts of the machine usually comprises a pair of side frames connected by a top plate or beam. One of these side frames is shown at 2 and the connecting top plate at 5. The side frames will be carried by a chambered supporting-base 3. The top plate or beam 5 is illustrated carrying a supply spout or chute H.

The base 3 will be provided with suitable supports for carrying the beam mechanism, which latter will support the bucket and its operative devices. The supports for the beam mechanism are shown at 20 and 20' as V-shaped bearings, which may be secured to the base 3 in any suitable manner. The beam mechanism is illustrated comprising a pair of oppositely-disposed counterweighted beams B and B'. Each of the beam-arms of the scale-beams will be provided with a pair of pivots or knife-edges 24 and 24', which will rest on or be supported by the V-shaped bearings 20 and 20', shown carried by the base 3.

Each of the scale-beams will also be provided near their inner ends with a pair of bucket-supporting knife-edges, one of which is illustrated at 15, which are adapted to support V-shaped bearings, one of which is illustrated at 17, carried by the hanger 555 of the bucket G.

It will be evident that as usual the beam mechanism will have poising and counterpoising portions. All that portion of the beam mechanism lying outside of the beam supports constitutes the counterpoising portion of the beam mechanism and all that portion of the beam mechanism lying or located inside of said beam-supports constitutes the poising portion of the beam mechanism. The bucket (designated in a general way by G) is of the well-known "single-chambered" type or class and is suspended with its receiving end or mouth under the supply chute or spout H to receive the supply-stream from the latter.

The bucket-closer, which is designated in a general way by L, is shown consisting of a suitably-formed plate or closer proper 75, having a counterweighted arm 79 preferably formed

integral therewith, and the closer is also illustrated pivoted at 78 to the lower side of the bucket G and adjacent to one side of the discharge-opening thereof.

5 As a means for supporting the bucket-closer, an inverted toggle connection is shown connecting the closer and the bucket. In the form illustrated this toggle connection comprises a rocker 550, which is shown pivoted  
10 adjacent to the upper rearward side of the bucket G. This rocker 550 is illustrated provided with a long connecting-rod 596, pivoted, respectively, to the rocker and to the closer in such a manner that when the closer is shut  
15 the two pivots of said connecting-rod will be nearly in line with and the upper of said pivots will be above the rocker-pivot, whereby when the rocker is engaged by a bucket-closer latch and held in that position the closer will  
20 be supported with a minimum pressure on the latch.

The closer-latch for locking the rocker in position and which is designated by 82 is shown pivoted at 87 to the bucket and having  
25 a detent or stop 81 in position and adapted for engaging a co-operating stop on the toggle connection when the parts are in the closed position previously described. (See Fig. 1).

The co-operating stop of the toggle connection is illustrated at 550' carried by the rocker 550. The bucket-closer latch 82 is shown counterweighted and will be limited  
30 in its movement toward the detent of the toggle connection by a suitable stop, such as 82''. It will be observed that the closer-latch will have an upward movement to engage the detent of the rocker and that the latch will be released by an opposite or downward  
35 movement.

40 In connection with the bucket mechanism and with the stream-supplying means therefor and with a stream-controlling valve a stop-register will be employed which will have a shiftable member normally held against movement and releasable at a predetermined point  
45 in the operation of the machine, and a valve-movement-limiting latch will also be employed, and the latch will be co-operative with the shiftable member of the stop-register and will have an effective movement into position  
50 for maintaining the valve in a closed position, and the latch itself will be held against movement while the shiftable member of the stop-register is in the normal position thereof.

55 As a means for controlling the supply-stream, a valve is shown at 70 substantially similar to that shown and described in Letters Patent No. 535,727, granted to Francis H. Richards March 12, 1895, and which will be  
60 pivoted at 70' between arms 5', projecting from the top plate or beam 5.

Suitable valve opening and closing mechanism will also be employed. As a means for closing the valve, a lever is shown at 504 pivoted to the frame, (see dotted lines, Figs. 1  
65 and 3,) which will have at its forward end a friction-roller 506, adapted to engage the cam-

surfaces 501 and 502 of a cam-lever and to oscillate the cam-lever and thereby the valve itself. The cam-lever is shown at 500 as a  
70 depending cam operable with the valve and having a reducing cam-face 501 and a cut-off cam-face 502. The lever 504 is shown counterweighted at its forward end, and the weight  
75 507 will be preferably adjustable. It will be obvious that by reason of the riding up of the roller 506 on the cam-faces of the cam 500 a progressively-decreasing leverage will be exerted on the valve for actuating the same during the closing movement thereof, and  
80 that by reason of the peculiar curvature of the cam-faces the force exerted by the weight 607, acting through the lever 504, will be applied to the valve in a peculiar ratio of decreasing efficiency, it being obvious that the  
85 cut-off cam-face 502 will have a relatively greater efficiency than the reducing cam-face 501, and that, therefore, the valve-closing actuator 504 will be effective to close the valve quickly when such friction-roll has passed  
90 from off the reducing cam-face 501.

In connection with the valve mechanism and with the closer two coacting stops are shown, one of which is shown at 412', operative with the valve and the other at 413' operative with the closer, and each in position  
95 and adapted for serving as a stop device for the other when the valve is open, (see Fig. 1,) and a second pair of stops, one of which is shown at 412' operative with the valve, and  
100 hence a valve-operative stop, and the other of which is illustrated at 550' operative with the closer and constitutes a closer-operative stop, and which are also positioned so that each serves as a stop device for the other while  
105 the closer is open. (See Fig. 3.) The closer-operative stop 550' is also shown having a stop-face 413', preferably cam-shaped and adapted to actuate the valve-operative stop 412' at the end of the normal cut-off movement of the  
110 valve for the purpose of imparting an additional closing movement to the valve. The closer-operative stop-face 413' also preferably has an ascending movement with the bucket, which will impart a further closing movement  
115 to the valve. These stops will be oscillatory relatively to each other, and one of the stops will be formed with its stop-face 412' cam-shaped and so positioned as to compensate for the downward movement of the bucket  
120 while the valve is open.

The rocker 550 is shown constituting the closer-operative stop for coacting with the valve to hold the valve in a closed position while the closer is open, as shown in Fig. 3,  
125 and hence this constitutes a valve-movement limiter for maintaining the valve in a closed position while the closer is open. The rocker 550 is also shown provided with a valve-stop 413' in the form of a friction-roller and also  
130 supplementary stop-faces 413' and 413''.

The valve is shown provided with a stop 412, illustrated as a friction-roller, and a supplementary stop-face 412', shown as a cam-

face defined by a curve approaching an arc struck from the axis of the valve, and which are intersects the curve of the cam-face at that end of said cam-face which is remote from the friction-roller or stop 412. The stop-face or friction-roller 412 is so organized relatively to the rocker 550 that it co-operates with the connected stop-faces 413' and 413'', while the stop-face or friction-roller 413 is positioned to co-operate with the stop-face 412', the stop-faces 412 and 413 being peripherally non-contiguous.

The valve 70 is shown provided with a connecting rod or arm 558, shown pivotally secured to the upper rear portion thereof, and as having the lower end of said rod in position and adapted to be engaged by a valve-opening actuator, which will now be described.

The connecting rod 558 is illustrated constituting the means for transmitting to the valve the valve-opening thrust of a valve-actuator. An actuator is shown at 551 constituting a supplemental counterpoise and normally forming a part of the counterpoising portion of the beam mechanism. Said actuator is shown at 551' pivoted to the scale-beam B between the bucket-supports, so that any downward pressure exerted on said actuator 551 will oscillate the same, and a very slight oscillatory movement will be necessary to shift the counterpoise 551 from the counterpoising portion to the poising portion of the beam mechanism. The connecting-rod 558 has been described as having its lower end in position and adapted to be engaged by a valve-opening actuator, and the actuator 551 constitutes the valve-opening actuator for engaging said rod to impart to the valve the valve-opening thrust. When free to actuate the valve to open the same, this rod 558 forms a part of the actuating means and therefore a part of the valve-opening actuator; but when the opening of the valve is prevented it will also be evident that said rod 558 serves as a stop for limiting or checking the valve-opening movement of the valve-opening actuator.

As it is necessary in the normal operation of a weighing-machine of this general class that the valve-opening movement of the valve-opening actuator be prevented during that period in which the load is being made up and after the valve has begun to close and partially closed, it will be evident that if the valve-opening-movement limiter is in its operative position it will be impossible for the valve-opening actuator 551 to be effective as such, as the rod 558 will engage said actuator and form a stop device for limiting or checking the valve-opening movement thereof.

When the weighing mechanism has come very near to the end of the poising period, it is important to instantly bring about the shifting movement of the closer L to thereby discharge the bucket-load. For holding the

closer normally against movement a latch 82 has been hereinbefore described. For tripping the latch 82 to thereby release the closer L a latch-actuator operable by the closing-valve will also be employed. The connecting-rod 558, which is shown operable with the valve 70, will be provided with a latch-actuator 88, which is adapted, at the close of the poising period, to engage a laterally-projecting arm 83 on said latch 82 to trip said latch to thereby release the rocker and hence the closer.

A stop-register will be employed for registering the bucket-loads, and I prefer to employ a stop-register somewhat similar to that shown and described in the patent to Francis H. Richards, No. 408,192; granted July 30, 1889. This stop-register is illustrated at R and is carried by the bucket, it being secured thereto in some suitable manner. The stop-register R will be now briefly described. The register will have a rock-shaft 30, constituting the shiftable member thereof, which is shown suitably journaled in the end walls of the protective casing. The shiftable member of the register will be normally held against movement, but will be released at a predetermined point in the operation of the machine or when a predetermined number of bucket-loads have been discharged, at which time said shiftable member will be free to shift in the manner hereinafter specified. The registering mechanism proper may be made in any well-known manner—for example, similar to that shown in the application of Francis H. Richards, Serial No. 558,200, filed August 5, 1895, to which I refer by permission. The rock-shaft 30 is shown provided with a series of peripherally-formed holding projections 35', 36', 37', and 38', which will be engaged by a series of holding or bell-crank levers, which are automatically released when a given quantity of bucket-loads have been discharged.

The back plate of the register-casing will have formed thereon a series of studs, four in number, on which are mounted the registering mechanism proper and the index-dials 30<sup>a</sup>, 30<sup>b</sup>, 30<sup>c</sup>, and 30<sup>d</sup>, which latter bear the usual ten numbers from "0" to "9." The studs for the index-dials and the registering mechanism are shown at 31, 32, 33, and 34. These dials will be provided with a circular series of recesses or holes, the purpose of which will now be described.

The back plate of the register-casing is shown having secured thereto for pivotal movement a series of bell-cranks or holding-levers 35, 36, 37, and 38, which are normally adapted for holding the rock-shaft or shiftable member 30 of the stop-register in the non-shiftable position. These bell-cranks or holding-levers 35, 36, 37, and 38 will be provided each with a hook for engaging the holding projections 35', 36', 37', and 38' on the rock-shaft 30 until at a predetermined period these will all be simultaneously released. To bet-

ter maintain the engagement of the bell-cranks or holding-lever, each will be provided with a suitable spring.

The normally-free ends of the bell-cranks or holding-levers 35, 36, 37, and 38 are each in position and adapted to be, at a certain point in the rotation of the index-dials, engaged by a suitable device to thereby release said holding-levers from engagement with the respective holding projections on the rock-shaft 30. A series of removable pins 31', 32', 33', and 34' are shown, which may be set in any one of the circular series of holes or recesses in each of the index-dials. Take, for example, the dial 30<sup>d</sup> and the pin 34', which is set in the hole corresponding to the number "0." It will be obvious that when the "0" is brought opposite the sight-opening (not shown) in the front plate the pin of the index-dial will be effective for engaging the normally-free end of the lever 38, thereby releasing said lever from engagement with the holding projection on the rock-shaft. It will also be obvious that when these pins are set in a certain series of holes—say 2, 5, and 0, respectively, in the hundreds, tens, and units dials—when two hundred and fifty loads have been weighed and discharged, each of the removable pins will be effective for tripping the holding-levers 35, 36, 37, and 38, the pin in the last index thousands dial being set at the zero-point. Hence it will be obvious that at a predetermined point, or when a given number of bucket-loads have been weighed out, the shiftable member of the stop-register will be released.

As hereinbefore stated, a valve-movement-limiting latch will be employed, and this latch will have an effective movement for holding the valve in a closed position.

The bucket G is illustrated provided with a plate 40, which will be secured thereto in some suitable manner, and this plate 40 will have formed thereon a pair of laterally-extending arms, constituting a bracket for supporting the valve-movement-limiting latch. The valve movement-limiting latch will be supported for oscillatory movement, and is shown at 41, pivoted between the arms of the supporting-bracket therefor, the pivot of said latch being shown at 41'. This valve-movement-limiting latch will be held against movement by and while the shiftable member of the register is in the non-shiftable position thereof and will be released simultaneously with the release of said shiftable member, so that it may be effective for maintaining the valve in a closed position when a predetermined number of bucket-loads have been discharged.

As a means for accelerating the effective movement of the valve-movement-limiting latch, this will be provided with a spring of relatively-strong power. Hence it will be evident that the valve-movement-limiting latch is a spring-pressed or spring-actuated

latch. The spring for exerting the power to carry the latch from the ineffective to the valve-movement-limiting or effective position thereof is shown at 42 and secured, respectively, to the latch 41 at a point above the pivot thereof and to the bucket G. The shiftable member of the stop-register constitutes the means for maintaining the latch 41 in the normal or ineffective position thereof; but immediately on the release of the shiftable member of the stop-register the latch 41 will, through the medium of the spring 42, be shifted from the ineffective position to the effective or valve-movement-limiting position thereof to maintain the valve in a closed position by the engagement of the rocker-detent 550' by said latch. It will be understood that the latch 41 will be held in the normally-ineffective position thereof while the shiftable member of the stop-register is in the non-shiftable position thereof.

The shiftable member of the register R is shown projecting a relatively-short distance beyond the casing thereof sufficiently far to carry suitable mechanism operatively connecting it with the valve-movement-limiting latch 41, and these connections will now be described.

The outer end of the rock-shaft 30 is shown provided with an upwardly-projecting arm 43, which will be secured to the rock-shaft for movement therewith in some suitable manner. The upper extremity of this arm 43 is shown pivoted to a connecting-link 44, which is shown also pivoted to the lower end of the latch 41. It will be evident that the movements of the latch 41 are governed by the shiftable member of the stop-register, and that when such shiftable member of the stop-register is in its non-shiftable position the latch will be held in its ineffective position, and that when said shiftable member of the stop-register is released the latch will also be released, whereby it will be then effective for limiting the valve-opening movement.

The register R will be operated by some movable part of the bucket mechanism, and that part is shown constituting the closer L. The register R will be provided with the usual actuating-lever 39 for actuating the register mechanism for counting the bucket-loads, and to this actuating-lever 39 and to the closer-arm 79 is shown, respectively, pivoted a long connecting-rod 39'.

It will be obvious that each time the closer or shiftable member of the bucket mechanism is released an additional load will be registered.

It will be understood from the preceding description that a stop member is provided which is directly connected with and is normally held against movement by the registering mechanism of the stop-register, and that this stop member is also adapted to be released and when released to have an effective

movement into position for intercepting the valve mechanism to thereby stop the operation of the machine.

It will also be understood that, in connection with the bucket-closer and with a valve for controlling the supply-stream, a pair of stops are employed, constituting, respectively, a valve-operative stop and a closer-operative stop, and that said stop member when released will have an effective movement into position for intercepting one of said stops.

The operation of a weighing machine embodying the present improvements, briefly described, is as follows: It will be assumed that it is desired to deliver, say, 250 bushels of a certain material and that the capacity of the bucket is one bushel. The pins 31', 32', 33' and 34' will be so set in the proper recesses in the index-dials as to release and cause the bell-cranks all to simultaneously trip and release the rock-shaft 30 when this number has been weighed and delivered by the bucket. It will also be assumed that the bucket is weighing the last load of this number and that the major portion of the load in the bucket is completed. When the bucket is at the close of the poising period, the latch-actuator will be effective to trip the latch 82, thereby releasing the closer L. As soon as the closer L is released, the rocker 550, constituting one member of the described closer-supporting toggle connection, will, by reason of the weight of the material resting on the closer, quickly rotate on its pivot and the rocker or valve-movement limiter 550 will be effective for holding the valve in a closed position. When the closer L has nearly reached the limit of its opening movement or when it is substantially in the position shown in Fig. 3, the last load of the predetermined number will be registered, and immediately when this last load has been registered the shiftable member of the register will be released. As soon as the shiftable member of the register is released, it holding the latch 41 against movement, the latter, through the agency of the spring 42, will be carried under the detent 550' of the rocker 550, the latch thereby being effective to hold the valve closed and maintain the same in such closed position. While the valve is in its closed position, as shown in Fig. 3, it will be noticed, on reference to Fig. 3, that the closer will also be held in the open position. The bucket, however, will be permitted to resume the normal position thereof, which is shown in Fig. 1. The latch 41 will be in engagement with the detent 550' of the rocker 550, and while this engagement continues the closer-operative stop will engage the valve-operative stop and will be effective for holding the valve in a closed position, and consequently the valve-operative stop will be operative for holding the closer open.

From the preceding description it will be apparent that, in connection with a bucket and with means for supplying a stream of material to the bucket and with valve mechanism

for controlling the supply-stream and with a stop-register and the load-registering mechanism thereof, a stop member will be employed which will be normally held against movement by the registering mechanism and will also be released at a predetermined point in the operation of the machine, and when released will have an effective movement into position for limiting the movement of the valve mechanism to thereby stop the operation of the machine.

Having thus described my invention, I claim—

1. In a weighing-machine, the combination with a bucket, and with a supply-chute for supplying a stream of material to the bucket; of valve mechanism; of a stop-register and the registering mechanism thereof; a stop-member directly connected with, and normally held against movement by, the registering mechanism, and adapted also to be released, and when released, to have an effective movement into position for intercepting the valve mechanism, substantially as specified.

2. In a weighing-machine, the combination with a bucket having a closer; of a supply-chute; a stream-controlling valve therefor; a valve-operative stop and a closer-operative stop, operative with the valve and with the closer; a stop-register having a shiftable stop-member normally held against movement, and adapted also to be released at a predetermined point in the operation of the machine, and having an effective movement into position for intercepting one of said stops, substantially as specified.

3. In a weighing-machine, the combination with a bucket mechanism; of means for supplying a stream of material to the bucket; a valve for controlling the stream; a stop-register having a shiftable member normally held against movement, and adapted to be released at a predetermined point in the operation of the machine; and a valve-movement-limiting latch co-operative with the shiftable member of the stop-register, and having an effective movement into position for maintaining the valve in a closed position, and having said latch held against such movement while the shiftable member of the stop-register is in the normal position thereof, substantially as specified.

4. In a weighing-machine, the combination with a bucket mechanism; of means for supplying a stream of material to the bucket; a valve for controlling the stream; a stop-register having a shiftable member normally held against movement, and adapted to be released at a predetermined point in the operation of the machine; and a spring-actuated valve-movement-limiting latch co-operative with the shiftable member of the stop-register, and having an effective movement into position for maintaining the valve in a closed position, and having said latch held against such movement while the shiftable member of the stop-

register is in the normal position thereof, substantially as specified.

5 In a weighing-machine, the combination with a bucket mechanism; of means for supplying a stream of material to the bucket; a valve for controlling the stream; a stop-register having a shiftable member normally held against movement, and adapted to be released at a predetermined point in the operation of the machine; and a valve-movement-limiting latch operatively connected with the shiftable member, and having an effective movement into position for maintaining the valve in a closed position, and held against such movement by the shiftable member while the latter is in the normal position thereof, substantially as specified.

6 In a weighing-machine, the combination with a bucket mechanism; of means for supplying a stream of material to the bucket; a valve for controlling the stream; a stop-register having a shiftable member normally held against movement, and adapted to be released at a predetermined point in the operation of the machine; a bracket carried by the bucket; and a valve-movement-limiting latch pivotally supported by said bracket, and co-operative with the shiftable member of the stop-register, and having an effective movement into position for maintaining the valve in a closed position, and having said latch held against such movement while the shiftable member of the stop-register is in the normal position thereof, substantially as specified.

7 In a weighing-machine, the combination with a bucket mechanism; of means for supplying a stream of material to the bucket; a valve for controlling the stream; a stop-register having a shiftable member normally held against movement, and adapted to be released at a predetermined point in the operation of the machine; a valve-movement limiter in position and adapted for holding the valve in a closed position; and a latch co-operative with the shiftable member of the stop-register, and having an effective movement into position for engaging the valve-movement limiter to maintain the same in the valve-limiting position thereof to thereby hold the valve closed, and having said latch normally held against such movement while the shiftable member of the stop-register is in the normal position thereof, substantially as specified.

8 In a weighing-machine, the combination with a bucket having a closer; of means for supplying a stream of material to the bucket; a valve for controlling the stream; a pair of stops operative with the valve and with the closer; and having the closer-operative stop

in position and adapted for engaging the valve-operative stop to maintain the valve in closed position; a stop-register having a shiftable member normally held against movement, and adapted to be released at a predetermined point in the operation of the machine; and a latch co-operative with the shiftable member and with the closer-operative stop, and having an effective movement into position for engagement with the closer-operative stop to thereby hold the valve in a closed position, and having said latch held against such movement while the shiftable member of the stop-register is in the normal position thereof, substantially as specified.

9 In a weighing-machine, the combination with a bucket having a closer; of means for supplying a stream of material to the bucket; a valve for controlling the stream; a pair of stops operative, respectively, with the valve and with the closer, and in position and adapted each for serving as a stop device for the other while the closer is open; a stop-register having a shiftable member normally held against movement, and adapted to be released at a predetermined point in the operation of the machine; and a latch co-operative with the shiftable member of the stop-register, and having an effective movement into position for engaging one of said pair of stops to thereby maintain the closer in the open position thereof, and having said latch held against such movement while the shiftable member of the stop-register is in the non-shiftable position thereof, substantially as specified.

10 In a weighing-machine, the combination with a bucket having a closer; of means for supplying a stream of material to the bucket; a valve for controlling the stream; a rocker operatively connected with the closer; a closer-latch for holding said rocker in a closer-movement-limiting position; an actuator in position and adapted for releasing said latch from engagement with the rocker to thereby permit the closer to open; a stop-register having a shiftable member normally held against movement, and adapted to be released at a predetermined point in the operation of the machine; and a latch having an effective movement for engaging the rocker when released to maintain the closer in the open position thereof, and having said latch held against such movement while the shiftable member of the stop-register is in the normal position thereof, substantially as specified.

FRANK E. THOMPSON.

Witnesses:  
FRED. J. DOLE,  
S. W. POTTS.