

(19) World Intellectual Property Organization  
International Bureau



(43) International Publication Date  
19 November 2009 (19.11.2009)

(10) International Publication Number  
**WO 2009/139743 A1**

(51) International Patent Classification:  
*G08B 21/00* (2006.01)

(21) International Application Number:  
PCT/US2008/006075

(22) International Filing Date:  
13 May 2008 (13.05.2008)

(25) Filing Language: English

(26) Publication Language: English

(71) Applicants (for all designated States except US): **ATLAS COPCO ROCK DRILLS AB** [SE/SE]; SE-701 91 Orebro (SE). **ATLAS COPCO DRILLING SOLUTIONS LLC** [US/US]; 2100 North First Street, Garland, TX 75040 (US).

(72) Inventors; and

(75) Inventors/Applicants (for US only): **KRAINER, Per** [SE/SE]; Dianavagen 26C, S-SE-771 42 Ludvika (SE). **JIAO, Deyi** [US/US]; 4101 Aldenham Drive, Plano, TX 75024 (US).

(74) Agent: **STONE, Mark, P.**; 50 Broadway, Hawthorne, New York 10532 (US).

(81) Designated States (unless otherwise indicated, for every kind of national protection available): AE, AG, AL, AM, AO, AT, AU, AZ, BA, BB, BG, BH, BR, BW, BY, BZ, CA, CH, CN, CO, CR, CU, CZ, DE, DK, DM, DO, DZ, EC, EE, EG, ES, FI, GB, GD, GE, GH, GM, GT, HN, HR, HU, ID, IL, IN, IS, JP, KE, KG, KM, KN, KP, KR, KZ, LA, LC, LK, LR, LS, LT, LU, LY, MA, MD, ME, MG, MK, MN, MW, MX, MY, MZ, NA, NG, NI, NO, NZ, OM, PG, PH, PL, PT, RO, RS, RU, SC, SD, SE, SG, SK, SL, SM, SV, SY, TJ, TM, TN, TR, TT, TZ, UA, UG, US, UZ, VC, VN, ZA, ZM, ZW.

(84) Designated States (unless otherwise indicated, for every kind of regional protection available): ARIPO (BW, GH, GM, KE, LS, MW, MZ, NA, SD, SL, SZ, TZ, UG, ZM, ZW), Eurasian (AM, AZ, BY, KG, KZ, MD, RU, TJ, TM), European (AT, BE, BG, CH, CY, CZ, DE, DK, EE, ES, FI, FR, GB, GR, HR, HU, IE, IS, IT, LT, LU, LV, MC, MT, NL, NO, PL, PT, RO, SE, SI, SK, TR), OAPI (BF, BJ, CF, CG, CI, CM, GA, GN, GQ, GW, ML, MR, NE, SN, TD, TG).

Published:

— with international search report (Art. 21(3))

(54) Title: ARRANGEMENT IN A DRILL RIG AND A METHOD FOR MONITORING AN AIR FLOW

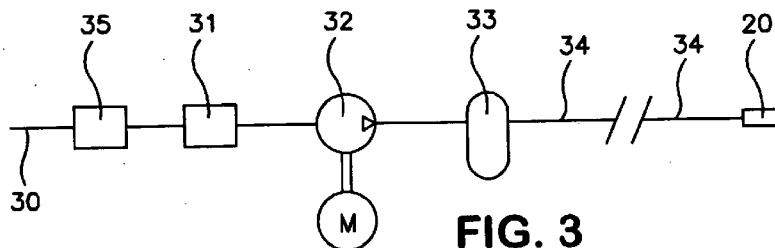

**FIG. 3**

(57) Abstract: The present invention relates to an arrangement in a drill rig. The arrangement comprises an inlet valve placed before the inlet to a displacement compressor that is used for supplying a flow of air via a pressure vessel to at least one flushing hole in the surface of a drill bit. The arrangement is used for detecting a reduced flow of air through the at least one flushing hole in the surface of the drilling bit. The arrangement further comprises means for detecting the quantity of air flowing through the inlet valve placed before the inlet to the displacement compressor. The invention furthermore relates to a method for indirectly monitoring of a reduced air flow through at least one flushing hole in the arrangement above.

WO 2009/139743 A1

**Title: Arrangement in a drill rig and a method for monitoring an air flow**

**Field of the invention**

The present invention relates to an arrangement in a drill rig in accordance with the preamble of the independent claim. The invention also relates to a method for detecting a reduced air flow through a flushing hole in a drill bit.

**Background of the invention**

Drill rigs in different sizes are frequently used in constructional work to drill holes in rocks. The drill rig comprises a drill bit adapted for the specific conditions of the rock and used to penetrate the rock, and chip away the fractured rocks. The penetration force is generated by either a high level feed force or percussive wave forms. The rotation torque generated by a rotation motor will shear off the fractured rock.

In rock drilling processes, it is standard practice to use compressed air to blow away the rock cuttings and clean the surface of the rock to ensure that the bit always is in contact with a fresh and solid rock surface. If the cuttings were not cleaned away, the drill bit would penetrate the cutting and further break down the cutting into smaller sizes. This secondary breakage is not wanted because of the considerable quantity of waste energy and reduced drilling efficiency. The accumulation of the cuttings will furthermore resist the rotation of the drill bit and eventually jam the bit to stop. It is consequently important to ensure a continuous air flow through the flushing holes on the drill bit.

The flow of air is however stopped if the flushing holes got plugged by mud or fine cuttings compacted into the flushing holes. This typically happens when the drilling is so fast that the air provided is not sufficient to clean the cuttings away. When the flushing holes are plugged, the drilling is stopped and the holes must be cleaned which takes a considerable time and stops the work completely.

Up to now, the detecting of a reduced, or stopped, air flow has been done by using an air flow monitoring device placed in the air flow path through which air is fed from the compressor to the drill bit. The working pressure in the path is however rather high, while the measurement of differential pressures are relatively very small, which means that the required monitoring device must be able to conduct

reliably measurements of the differential pressure in this environment, which makes them have a high production and maintenance cost.

Furthermore, the monitoring device gives rise to a pressure drop in the air flow path which will have a negative impact on the air flow out through the flushing holes in the drill bit.

An improved arrangement and method for detecting a reduced, or stopped, air flow through the flushing holes are therefore requested.

#### Summary of the invention

The problems defined above are solved by an arrangement according to claim 1, and a detecting method as defined in claim 5.

The claimed arrangement comprises an inlet valve placed before the inlet to a displacement compressor that is used for supplying a flow of air via a pressure vessel to at least one flushing hole in the surface of a drill bit, said arrangement is used for indirectly detecting a reduced flow of air through the at least one flushing hole in the surface of the drilling bit. The arrangement further comprises means for detecting the quantity of air flowing through the inlet valve placed before the inlet of the displacement compressor.

The claimed arrangement makes it possible to move the measuring point for monitoring the flow of air through the flushing holes in the drill bit from down stream of the compressor to up stream of the compressor. This arrangement has several advantages since the required means for detection of the flow up stream of the compressor is less complex and expensive. Secondly the negative pressure drop in the flow path is eliminated, and furthermore the results from the conducted measurements up stream of the compressor are more reliable.

In one embodiment of the present invention the detection of the quantity of air flowing through the inlet valve is indirectly detected by measuring the pressure in the flow path for air to the inlet valve placed before the inlet of the compressor. In this embodiment of the arrangement a pressure sensor is used for measuring the pressure in the flow path to the inlet valve and thereby indirectly monitoring the

flow of air through the flushing holes. Pressure sensors provide reliable measuring results, and are components that are readily available and easy to install.

In a further preferred embodiment of the present invention the detection of the quantity of air flowing through the inlet valve is indirectly detected by measuring the size of the flow area in the inlet valve. This is possible in an arrangement where the inlet valve is controlled by means that is measuring the pressure in the flow path from the compressor and, in case of a blocked flushing hole in the drill bit, close to the inlet valve to avoid that the system pressure in the flow path from the compressor to the drill bit increase further. Since the flow area is adjusted depending on the system pressure in the flow path, measurement of the flow area in the inlet valve, which is easy to detect, will indirectly provide information about the pressure in the flow path from the compressor and the air flow through the flushing holes in the drill bit.

The present invention also relates to a method for detecting a reduced air flow through a flushing hole in a front surface of a drilling bit in an arrangement according to anyone of claims 1 to 4, comprising the steps:

- detecting the quantity of air flowing through an inlet valve placed upstream of a displacement compressor;
- compare the detected quantity of air flow with a predetermined value and if the value is lower than the predetermined value, send a signal to a control device to stop, or reduce the speed of the drilling bit, and if the detected value is equal or higher than the predetermined value, continue drilling and repeat the first step at predetermined intervals.

The claimed method provides a reliable method for monitoring the flow of air through the flushing hole in the drill bit without the use of complex and expensive measuring equipment. Furthermore, the monitoring is done by detecting the flow of air upstream of the compressor which is considerably easier than in previous arrangements and methods.

#### Brief description of the drawing

One embodiment of the present claimed invention is schematically illustrated in the appended figures, in which:

Figure 1 illustrates a drill rig in which the claimed arrangement is used;

Figure 2 illustrates a perspective view of a drill bit, and  
Figure 3 discloses the claimed arrangement schematically.

#### Detailed description

In figure 1 a drill rig 10 is illustrated. The rig 10 is used for drilling holes in different types of constructional work. The rig 10 comprises a rig body 11 that comprises machinery for enabling transport of the rig, as well as for providing the required power to conduct the drilling. The drill is placed in the outer end of an elongated arm 12 that extend forward from the rig body 11. The arm is manoeuvrable to be easily movable to the intended position of the hole.

A drill bit 20, illustrated in figure 2, is used for penetrating the rock and chip away the fractured rocks. The front surface 21 of the drill bit 20 is provided with a number of drill elements 22 that are used for penetrating the rock. The front surface is furthermore provided with four flushing holes 23. Compressed air, provided from a displacement compressor placed in the rig body 11, is flowing out from the flushing holes 23 in order to blow the rock cuttings away and clean the surface of the rock to ensure that the drill bit 20 always is in contact with fresh and solid rock surface in order to keep the drilled hole free from already cut rock.

Figure 3 discloses the claimed arrangement schematically. The arrangement comprises an air inlet flow path 30 through which air to a compressor 32, powered by a power source M, is lead via an inlet valve 31. The compressed air from the compressor 32 is passed on to a pressure vessel 33. Air is fed from the pressure vessel 33 via an air flow path 34 to the drill bit 20 where it exits the bit via the flushing holes 23. The arrangement furthermore comprises means 35 for detecting the air flow in the inlet flow path 30.

In one embodiment of the present invention the air flow through the flushing holes 23 in the drill bit 20 is monitored by detecting the air flow through the inlet flow path 30 indirectly by measuring the pressure in the inlet flow path 30. If the flushing holes 23 in the drill bit 20 for some reason are plugged, the system pressure in the flow path 34 to the drill bit 20 will rise due to the plugged outlets. The plugged outlets furthermore results in an increased pressure in the flow path 30 to the inlet valve 31 and the compressor 32 that is detected by a pressure sensor, not illustrated, that is measuring the pressure in the flow path 30.

In another embodiment of the present invention the air flow through the flushing holes 23 in the drill bit 20 is monitored by measuring the flow area within the inlet valve 32. The inlet valve 32 is used for regulating the quantity of air that is supplied to the compressor 33 in order to avoid that system pressure from rising if the air flow through the flushing holes 23 in the drill bit 20 is plugged. The system pressure in the flow path 34 is measured and the measured value used for the control of the inlet valve 31. The air flow through the flushing holes 23 in the drill bit 20 could therefore be monitored by measuring the area or the position of the inlet valve 31 which is considerably easier and causes no pressure drop in the flow path 34 to the drill bit 20.

Both embodiments of the present invention described above also provides a more reliably monitoring of the air flow since the determination of the air flow in the flow path 30 is either based on an increased pressure or a reduced flow area which is easy to measure compared to the existing solutions.

While two presently preferred embodiments of the invention have been described herein, it is to be understood that the invention is not so limited but covers and includes any and all modifications and variations that are encompassed by the following claims.

**Claims**

1. Arrangement in a drill rig comprising an inlet valve placed before the inlet to a displacement compressor that is used for supplying a flow of air via a pressure vessel to at least one flushing hole in the surface of a drill bit, said arrangement being used for detecting a reduced flow of air through the at least one flushing hole in the surface of the drilling bit, **characterized in** that said arrangement further comprises means for detecting the quantity of air flowing through the inlet valve placed before the inlet to the displacement compressor.
2. Arrangement according to claim 1, wherein the displacement compressor is a screw compressor.
3. Arrangement according to claim 1 or 2, wherein the detection of the quantity of air flowing through the inlet valve is indirectly detected by measuring the pressure in the flow path for air to the inlet valve placed before the inlet of the compressor.
4. Arrangement according to claim 1 or 2, wherein the detection of the quantity of air flowing through the inlet valve is indirectly detected by measuring the size of the flow area in the inlet valve, said inlet valve being controlled by means that is measuring the pressure in the flow path to the drill bit.
5. Method for indirectly detecting a reduced air flow through at least one flushing hole in a front surface of a drilling bit in an arrangement according to anyone of claims 1 to 4, comprising the steps:
  - a) detecting the quantity of air flowing through an inlet valve placed upstreams of a displacement compressor;
  - b) compare the detected quantity of air flow with a predetermined value and if the value is lower than the predetermined value, send a signal to a control device to stop, or reduce the speed of the drill bit, and if the detected value is equal or higher than the predetermined value, continue drilling and repeat the first step at predetermined intervals.

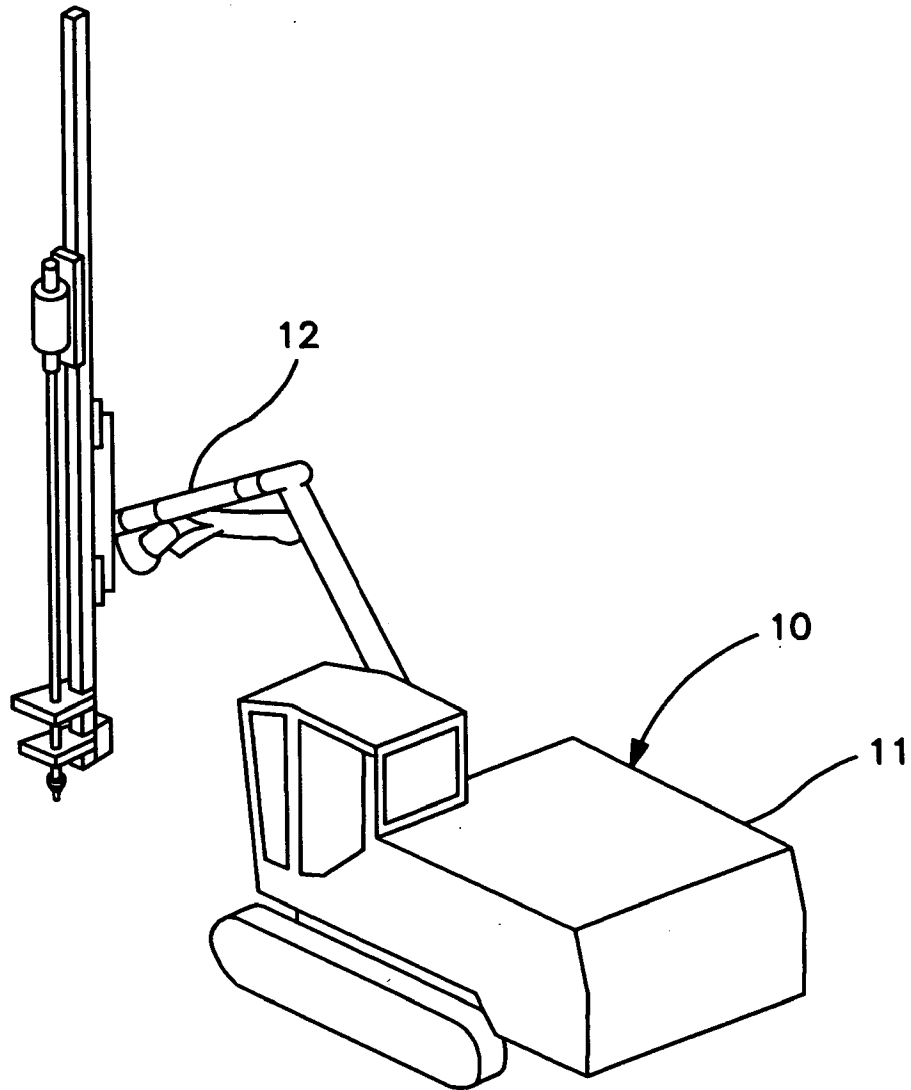

**FIG. 1**

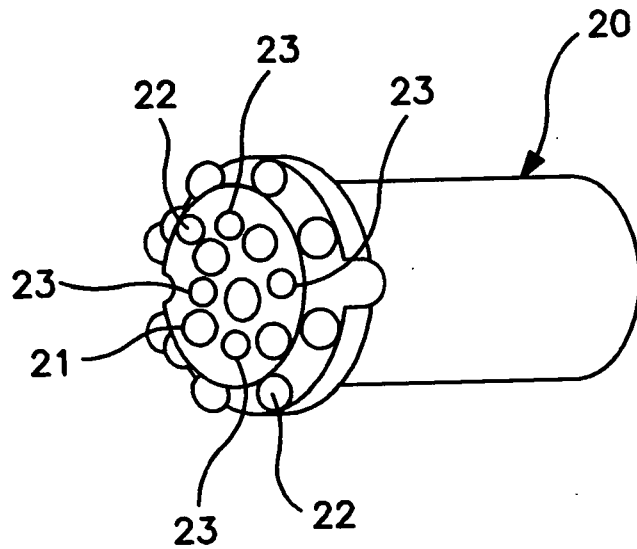

**FIG. 2**

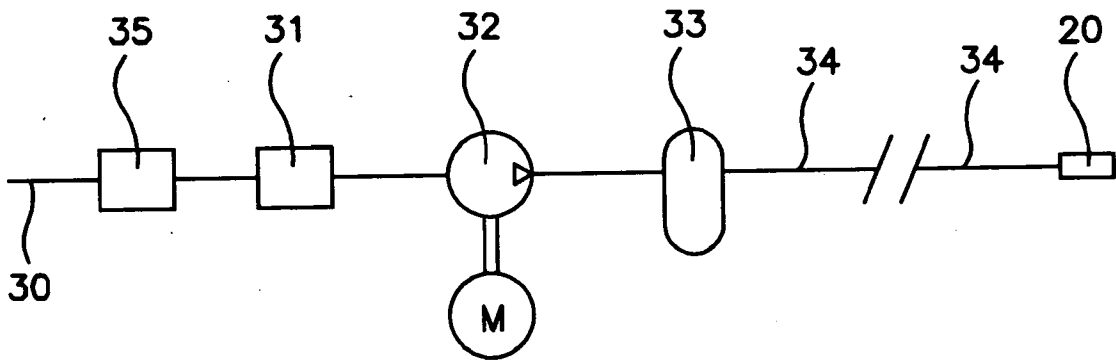

**FIG. 3**

**INTERNATIONAL SEARCH REPORT**

International application No.  
PCT/US 08/06075

<p><b>A. CLASSIFICATION OF SUBJECT MATTER</b>                  IPC(8) - G08B 21/00 (2008.04)                  USPC - 340/626                  According to International Patent Classification (IPC) or to both national classification and IPC</p>											
<p><b>B. FIELDS SEARCHED</b></p> <p>Minimum documentation searched (classification system followed by classification symbols)                  USPC - 340/626</p> <p>Documentation searched other than minimum documentation to the extent that such documents are included in the fields searched                  USPC - 340/500, 501, 540, 603, 626; 408/56 -- text search, see search terms below</p> <p>Electronic data base consulted during the international search (name of data base and, where practicable, search terms used)                  PubWEST(PGPB,USPT,USOC,EPAB,JPAB); Google Scholar                  Search Terms Used: drill, rig, air, flow, pressure, bit, flushing, hole, flush, plug, detect, measur, reduc, stop, low, valve, channel, compressor, speed</p>											
<p><b>C. DOCUMENTS CONSIDERED TO BE RELEVANT</b></p> <table border="1" style="width:100%; border-collapse: collapse;"> <thead> <tr> <th style="width:10%;">Category*</th> <th style="width:70%;">Citation of document, with indication, where appropriate, of the relevant passages</th> <th style="width:20%;">Relevant to claim No.</th> </tr> </thead> <tbody> <tr> <td align="center">Y</td> <td>US 5,235,324 A (GAGNEBIN) 10 August 1993 (10.08.1993), especially Figs 1A, 2A, 2B, 4, 5, 6; col 1, ln 9-20, 33-36; col 2, ln 15-27, 63-64; col 3, ln 1-9; col 4, ln 1-8; col 5, ln 53-54; col 6, ln 4-12.</td> <td align="center">1-5</td> </tr> <tr> <td align="center">Y</td> <td>US 2004/0173379 A1 (LEPPANEN) 09 September 2004 (09.09.2004), especially Fig 5; para [0008], [0019], [0029], [0043], [0046].</td> <td align="center">1-5</td> </tr> </tbody> </table>			Category*	Citation of document, with indication, where appropriate, of the relevant passages	Relevant to claim No.	Y	US 5,235,324 A (GAGNEBIN) 10 August 1993 (10.08.1993), especially Figs 1A, 2A, 2B, 4, 5, 6; col 1, ln 9-20, 33-36; col 2, ln 15-27, 63-64; col 3, ln 1-9; col 4, ln 1-8; col 5, ln 53-54; col 6, ln 4-12.	1-5	Y	US 2004/0173379 A1 (LEPPANEN) 09 September 2004 (09.09.2004), especially Fig 5; para [0008], [0019], [0029], [0043], [0046].	1-5
Category*	Citation of document, with indication, where appropriate, of the relevant passages	Relevant to claim No.									
Y	US 5,235,324 A (GAGNEBIN) 10 August 1993 (10.08.1993), especially Figs 1A, 2A, 2B, 4, 5, 6; col 1, ln 9-20, 33-36; col 2, ln 15-27, 63-64; col 3, ln 1-9; col 4, ln 1-8; col 5, ln 53-54; col 6, ln 4-12.	1-5									
Y	US 2004/0173379 A1 (LEPPANEN) 09 September 2004 (09.09.2004), especially Fig 5; para [0008], [0019], [0029], [0043], [0046].	1-5									
<p><input type="checkbox"/> Further documents are listed in the continuation of Box C. <input type="checkbox"/></p>											
<p>* Special categories of cited documents:</p> <table style="width:100%;"> <tr> <td style="width:50%;"> <p>"A" document defining the general state of the art which is not considered to be of particular relevance</p> <p>"E" earlier application or patent but published on or after the international filing date</p> <p>"L" document which may throw doubts on priority claim(s) or which is cited to establish the publication date of another citation or other special reason (as specified)</p> <p>"O" document referring to an oral disclosure, use, exhibition or other means</p> <p>"P" document published prior to the international filing date but later than the priority date claimed</p> </td> <td style="width:50%;"> <p>"T" later document published after the international filing date or priority date and not in conflict with the application but cited to understand the principle or theory underlying the invention</p> <p>"X" document of particular relevance; the claimed invention cannot be considered novel or cannot be considered to involve an inventive step when the document is taken alone</p> <p>"Y" document of particular relevance; the claimed invention cannot be considered to involve an inventive step when the document is combined with one or more other such documents, such combination being obvious to a person skilled in the art</p> <p>"&amp;" document member of the same patent family</p> </td> </tr> </table>			<p>"A" document defining the general state of the art which is not considered to be of particular relevance</p> <p>"E" earlier application or patent but published on or after the international filing date</p> <p>"L" document which may throw doubts on priority claim(s) or which is cited to establish the publication date of another citation or other special reason (as specified)</p> <p>"O" document referring to an oral disclosure, use, exhibition or other means</p> <p>"P" document published prior to the international filing date but later than the priority date claimed</p>	<p>"T" later document published after the international filing date or priority date and not in conflict with the application but cited to understand the principle or theory underlying the invention</p> <p>"X" document of particular relevance; the claimed invention cannot be considered novel or cannot be considered to involve an inventive step when the document is taken alone</p> <p>"Y" document of particular relevance; the claimed invention cannot be considered to involve an inventive step when the document is combined with one or more other such documents, such combination being obvious to a person skilled in the art</p> <p>"&amp;" document member of the same patent family</p>							
<p>"A" document defining the general state of the art which is not considered to be of particular relevance</p> <p>"E" earlier application or patent but published on or after the international filing date</p> <p>"L" document which may throw doubts on priority claim(s) or which is cited to establish the publication date of another citation or other special reason (as specified)</p> <p>"O" document referring to an oral disclosure, use, exhibition or other means</p> <p>"P" document published prior to the international filing date but later than the priority date claimed</p>	<p>"T" later document published after the international filing date or priority date and not in conflict with the application but cited to understand the principle or theory underlying the invention</p> <p>"X" document of particular relevance; the claimed invention cannot be considered novel or cannot be considered to involve an inventive step when the document is taken alone</p> <p>"Y" document of particular relevance; the claimed invention cannot be considered to involve an inventive step when the document is combined with one or more other such documents, such combination being obvious to a person skilled in the art</p> <p>"&amp;" document member of the same patent family</p>										
<p>Date of the actual completion of the international search 25 August 2008 (25.08.2008)</p>		<p>Date of mailing of the international search report <b>04 SEP 2008</b></p>									
<p>Name and mailing address of the ISA/US                  Mail Stop PCT, Attn: ISA/US, Commissioner for Patents                  P.O. Box 1450, Alexandria, Virginia 22313-1450                  Facsimile No. 571-273-3201</p>		<p>Authorized officer:                  Lee W. Young                  PCT Helpdesk: 571-272-4300                  PCT OSP: 571-272-7774</p>									