



INTERNATIONAL APPLICATION PUBLISHED UNDER THE PATENT COOPERATION TREATY (PCT)

<p>(51) International Patent Classification ⁶ : G11B 5/55, 5/48</p>	<p>A1</p>	<p>(11) International Publication Number: WO 95/13610 (43) International Publication Date: 18 May 1995 (18.05.95)</p>
<p>(21) International Application Number: PCT/US94/12677 (22) International Filing Date: 7 November 1994 (07.11.94) (30) Priority Data: 151,346 12 November 1993 (12.11.93) US (71) Applicant: CONNER PERIPHERALS, INC. [US/US]; 3081 Zanker Road, San Jose, CA 95134 (US). (72) Inventors: STEFANSKY, Frederick, Mark; P.O. Box 8011, Longmont, CO 80501 (US). HASE, Karl, E.; 22259 Highway 7, Lyons, CO 80504 (US). BRYAN, William, J.; 3664 Roundtree Court, Boulder, CO 80304 (US). LERDAL, Michael, J.; 2119 Sherry Mar Street, Longmont, CO 80501 (US). (74) Agents: FLIESLER, Martin, C. et al.; Fliesler, Dubb, Meyer and Lovejoy, Suite 400, Four Embarcadero Center, San Francisco, CA 94111-4156 (US).</p>		<p>(81) Designated States: CA, CN, JP, European patent (AT, BE, CH, DE, DK, ES, FR, GB, GR, IE, IT, LU, MC, NL, PT, SE). Published <i>With international search report. Before the expiration of the time limit for amending the claims and to be republished in the event of the receipt of amendments.</i></p>

(54) Title: STACKABLE ACTUATOR ASSEMBLY

(57) Abstract

An actuator assembly includes a first actuator arm and a second actuator arm, each having a first end and a second end, a support member, and a bearing assembly coupled to the arms and the support member, and supporting the arms and support member for rotation about an axis. The bearing assembly has a first portion abutting the first actuator arm and second portion abutting the second actuator arm, with the first and second arms being secured against movement away from each other by the bearing cartridge. Also provided is a retainer for preventing rotation of the first actuator arm about said axis relative to the second arm. The retainer may comprise first and second fasteners provided at opposite sides of the axis. In an alternative embodiment, the retainer comprises leaf spring having a notch provided therein on the first and second actuator arms, and a fastener member provided on the support member.

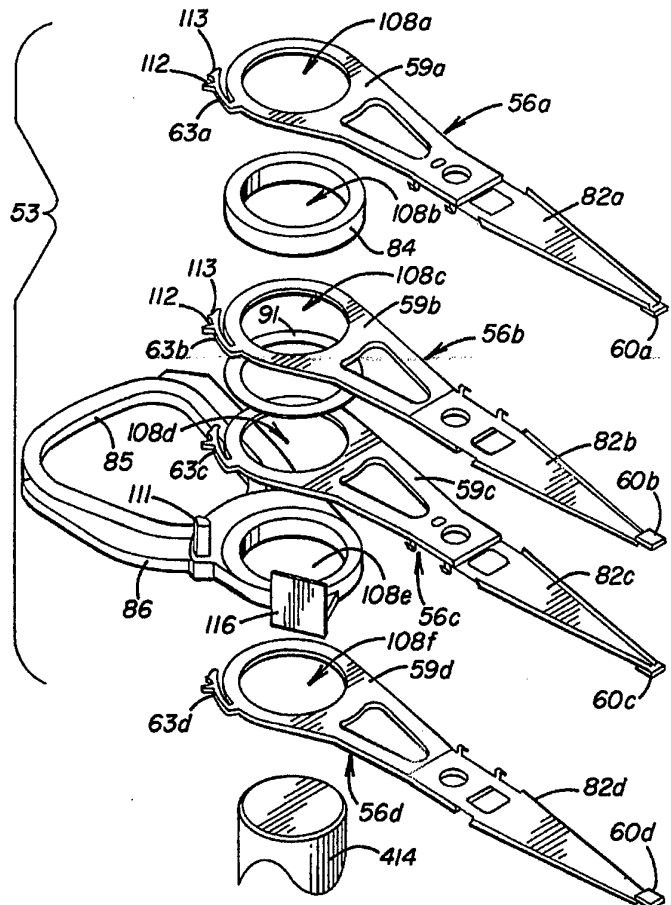

FOR THE PURPOSES OF INFORMATION ONLY

Codes used to identify States party to the PCT on the front pages of pamphlets publishing international applications under the PCT.

AT	Austria	GB	United Kingdom	MR	Mauritania
AU	Australia	GE	Georgia	MW	Malawi
BB	Barbados	GN	Guinea	NE	Niger
BE	Belgium	GR	Greece	NL	Netherlands
BF	Burkina Faso	HU	Hungary	NO	Norway
BG	Bulgaria	IE	Ireland	NZ	New Zealand
BJ	Benin	IT	Italy	PL	Poland
BR	Brazil	JP	Japan	PT	Portugal
BY	Belarus	KE	Kenya	RO	Romania
CA	Canada	KG	Kyrgystan	RU	Russian Federation
CF	Central African Republic	KP	Democratic People's Republic of Korea	SD	Sudan
CG	Congo	KR	Republic of Korea	SE	Sweden
CH	Switzerland	KZ	Kazakhstan	SI	Slovenia
CI	Côte d'Ivoire	LI	Liechtenstein	SK	Slovakia
CM	Cameroon	LV	Latvia	SN	Senegal
CN	China	LK	Sri Lanka	TD	Chad
CS	Czechoslovakia	LU	Luxembourg	TG	Togo
CZ	Czech Republic	LV	Latvia	TJ	Tajikistan
DE	Germany	MC	Monaco	TT	Trinidad and Tobago
DK	Denmark	MD	Republic of Moldova	UA	Ukraine
ES	Spain	MG	Madagascar	US	United States of America
FI	Finland	ML	Mali	UZ	Uzbekistan
FR	France	MN	Mongolia	VN	Viet Nam
GA	Gabon				

- 1 -

STACKABLE ACTUATOR ASSEMBLY

5

10 CROSS-REFERENCE TO RELATED APPLICATIONS

 WIRE CARRIER FOR DISK DRIVE ACTUATOR, U.S. Patent
Application Serial No. _____, filed November 12,
1993, inventors Karl E. Hase, William J. Bryan, and
15 Mike Lerdal, owned by the assignee of the present
application.

 AUTOMATED ASSEMBLY DISK DRIVE ARCHITECTURE, U.S.
Patent Application Serial No. _____, filed
November 12, 1993, inventors F. Mark Stefansky, Karl E.
20 Hase, William J. Bryan, and Mike Lerdal, owned by the
assignee of the present application.

 These applications are specifically incorporated
herein by reference.

25 BACKGROUND OF THE INVENTIONField of the Invention

 The invention relates to positioning mechanisms
for recording apparatus in information storage devices,
30 and particularly to actuators for positioning
read/write heads in disk drives.

Description of the Related Art

 Storage technology has followed a trend of
35 increasing storage capacity while simultaneously
decreasing the amount of physical space required to

- 2 -

maintain such capacities. Market pressure has in turn driven the monetary cost per mega-byte of storage down. In order to maintain a market advantage, new drive designs incorporate greater efficiency in both design
5 tolerance and manufacturability.

A key aspect in reducing the cost of drives is in improving manufacturability of components. In manufacturing rotary actuators, which position the read/write elements with respect to the storage medium,
10 the assembly includes a cast or extruded side facing "u" or e-shaped block (generally referred to as the e-block), usually made of aluminum or magnesium, to which suspension (or load beams) which support the read/write elements are attached. The e-block consists
15 of a cylindrical section into which a bearing assembly is installed, two, three, or any number of identical and aligned arms extending from the cylindrical section at an evenly spaced distance apart, and some form of attachment for a stepper motor or voice coil motor
20 component. The load beams are attached to the e-block such that the read/write elements are in as perfect alignment as possible for purposes of data recovery and the control electronics of the data storage device.

Generally, attachment of the load beams to the
25 e-block arms is performed by staking, a process whereby the body and a member to be joined to the body are positioned adjacent to each other, each with a like-sized bore at the joinder location, after which a steel ball bearing is forced through the respective bores.

30 Several problems are noteworthy with this approach. First, the cost of manufacturing the e-block is rather high. Each e-block is the result of a casting mold which must be made to specification for each drive. Second, the load beams must be attached in

- 3 -

a manual fashion. Generally, the read/write heads are attached to the load beams prior to assembly of the beams and the e-block. Thus, alignment of the heads and the load beams must occur at this time, and it is
5 difficult if not impossible to maintain perfect alignment of the heads during the staking process.

As is generally well known, if the recording technology employed is that of a magnetic hard disk drive, each head includes a slider body and a recording
10 gap which is on the order of 5 microns in length. In an "air bearing" disk drive, the slider body lifts off the surface of the storage medium and "flies" over the surface of the disk on a bearing of air. It is very important in such drives that the distance between the
15 head (and thus the recording gap) and the disk be maintained at an accurate level. Flying heights are on the order of microinches and maintaining such distances is extremely difficult. Thus, while the optimal drive design may call for a flying height of 2 microinches,
20 in reality, the drive is designed to accommodate variance of up to 1 microinch in the flying height.

To maintain such heights, each load beam is provided with a specific spring force with respect to the disk. Such forces are usually added to by
25 including a gram load on the head to increase the resistance of the head to movement away from the disk. Such factors complicate the design and fabrication operations, and increase the cost of the drive.

In addition, the assembly operation of the
30 actuator, and hence the drive as a whole, are somewhat manually intensive. The alignment of the load beams and heads must be supervised and monitored by a human being, thus increasing the cost and decreasing the speed of assembly of the drives.

- 4 -

An alternative to the e-block and staking assembly described above is a unitary load beam and actuator arm plate assembly such as that described in U.S. Patent Application Serial No. 07/757,709 filed September 11, 1991, inventors F. Mark Stefansky, Louis J. Shrinkle and Thomas A. Fiers, commonly owned and hereby incorporated by reference. An assembly similar to this is manufactured by Hutchenson Corporation and generally known as the Hutchenson Unamount suspension. The unamount suspension comprises a load beam coupled to a flat mounting plate which includes a circular bore which, when coupled to spacer elements, is designed to receive a bearing assembly.

The use of the unitary suspension eliminates the staking process, but raises additional issues in the form of securing the suspensions together in a format which is rigid enough to resist shock and vibration specifications in the drive.

SUMMARY OF THE INVENTION

An object of the present invention is to decrease the cost associated with providing a reliable, high capacity storage means.

A further object of the present invention is to provide a means for automating the assembly process of disk drives.

Yet another object of the present invention is to improve the manner in which tolerances are maintained in disk drives.

Yet another object of the invention is to provide the above objects through the provision of a novel actuator assembly.

These and other objects of the invention are provided in an actuator assembly. The assembly

- 5 -

includes a first actuator arm and a second actuator arm, each having a first end and a second end, a support member, and a bearing assembly coupled to the arms and the support member and supporting the arms and support member for rotation about an axis. The bearing assembly has a first portion abutting the first actuator arm and second portion abutting the second actuator arm, with the first and second arms being secured against movement away from each other by the bearing cartridge. Also provided is a retainer for preventing rotation of the first actuator arm about said axis relative to the second arm.

In one embodiment, the retainer comprises first and second fasteners provided at opposite sides of the axis. In an alternative embodiment, the retainer comprises leaf spring having a notch provided therein on the first and second actuator arms, and a fastener member provided on the support member. In such embodiment, the notch in each leaf spring engages the fastener member to secure the actuator arms. In still another aspect, the support member includes a coil assembly mounted thereon.

The actuator assembly of the present invention makes possible a novel method of manufacturing disk drives which reduces the cost of the drives and increases the accuracy to which design tolerances in the drive can be maintained. This reduces the cost per unit of storage and increases the efficiency with which drives are produced.

BRIEF DESCRIPTION OF THE DRAWINGS

The invention will be described with respect to the particular embodiments thereof. Other objects, features, and advantages of the invention will become

apparent with reference to the specification and drawings in which:

Figure 1A is a perspective view of a disk drive in accordance with the present invention.

5 Figure 1B is a plan view of a disk drive in accordance with the present invention.

Figure 1C is a second plan view of the disk drive.

Figure 1D is a cutaway view along line D-D in Figure 1C of the disk drive of the present invention.

10 Figure 1E is a cross-sectional view of a second motor assembly suitable for use in the disk drive.

Figure 2 is a perspective view of a first embodiment of an assembled actuator arm assembly in accordance with the present invention.

15 Figure 3 is an exploded perspective view of an actuator arm assembly in accordance with the present invention.

Figure 4A is a plan view of an arm plate of the arm assembly of the present invention.

20 Figure 4B is a side view of an arm assembly in accordance with the present invention.

Figure 4C is a plan view of a second embodiment of an arm assembly in accordance with the present invention.

25 Figure 5 is an exploded perspective view of second actuator arm assembly in accordance with the present invention.

30 Figure 6A is a perspective view of the actuator assembly with the arm assemblies rotated out of alignment.

Figure 6B is a perspective view of the actuator assembly of Figure 5 with the arm assemblies rotated into alignment.

- 7 -

Figure 6C is an isometric view of a pallet suitable for use in fabricating the actuator of the present invention.

5 Figure 7 is a perspective view of one arm of the actuator assembly with a first embodiment of a wire carrier in accordance with the present invention.

Figure 8A is a side view of a portion of the actuator arm of Figure 7.

Figure 8B is a view along line A-A of Figure 6A.

10 Figure 8C is a top view of the wire carrier shown in Figure 7.

Figure 9 is a first perspective view of the first embodiment of the wire carrier attached to a mounting arm in accordance with the actuator assembly described herein.

15 Figure 10 is a second perspective view of the first embodiment of the wire carrier attached to a mounting arm.

20 Figure 11 is a first perspective view of the first embodiment of the wire carrier.

Figure 12 is a second perspective view of the first embodiment of the wire carrier.

Figure 12A is an exploded view of a portion of the first embodiment of the wire carrier.

25 Figure 13 is a perspective view of a second embodiment of a wire carrier in accordance with the present invention.

30 Figure 14 is a planar view of a second embodiment of a wire carrier in accordance with the present invention.

Figure 15 is an enlarged perspective view of one end of a second embodiment of a wire carrier in accordance with the present invention.

- 8 -

Figure 16A is a perspective view of a first embodiment of a solderless wire coupling fixture suitable for use with the wire carrier of the first embodiment of the present invention.

5 Figure 16B is a perspective view of a wire carrier utilizing the first embodiment of the solderless coupling with the first or second embodiments of the wire carrier of the present invention.

10 Figure 17A is a top view and Figure 17B a side view, along line B-B in Figure 17A, of a second embodiment of a solderless wire coupling assembly suitable for use with the wire carrier of the present invention.

15 Figure 18A is an exploded, top view of a second embodiment of a solderless wire coupling assembly suitable for use with the wire carrier of the present invention.

Figure 18B is a view along line B-B in Figure 18A.

20 Figure 18C is an assembled, top view of the second embodiment of a solderless wire coupling assembly suitable for use with the wire carrier of the present invention.

25 Figure 18D is a detailed view of the head lead wire termination and flexible tab suitable for use with the second embodiment of the wire carrier of the present invention.

30 Figure 19 is an exploded, top view of a third embodiment of a solderless wire coupling assembly suitable for use with the wire carrier of the present invention.

Figures 20A and 20B are an exploded, top view, and an assembled top view, respectively, of a solderless wire coupling assembly suitable for use with the wire carrier of the present invention.

- 9 -

Figures 21A and 21B are top and side views, respectively, of another embodiment of a solderless wire coupling assembly.

Figure 22 is a perspective view of an apparatus suitable for implementing the assembly process of the disk drive in accordance with the present invention.

Figure 23 is a flowchart of a process for assembling a disk drive in accordance with the present invention.

10

DESCRIPTION OF THE PREFERRED EMBODIMENTS

An architecture for an automated disk drive assembly and a method for assembling the disk drive architecture will be described with reference to Figures 1-23. It should be recognized that while certain specific features of the invention will be described herein, the principles of the invention are equally applicable to numerous sizes, types, and technologies utilized in data storage devices incorporating the field of storage technology.

20

The disk drive described herein includes, for example, two hard disks, each with a magnetic coating and utilizing Winchester technology; however, the disk drive may utilize various numbers of disks (and a corresponding number of heads, usually one per disk surface, i.e., two (2) heads per disk) including a single disk. In addition, the drive of the present invention may incorporate other types of disks, for example, optical disks, and other read/write technologies, for example, lasers.

30

In one aspect, the architecture includes a novel actuator assembly which may be fabricated using an automated process and which allows for the elimination of prior art staking operations which reduce the

- 10 -

efficiency of the actuators. The novel actuator assembly allows actuator design tolerances to be maintained to a greater extent than in the prior art, with the advantage that the flying height variance of the read/write heads is substantially reduced.

Overall Drive Architecture

As shown in Figures 1A-1E a disk drive 30 in accordance with the present invention includes two main components, a head-disk-assembly (HDA) 32 and control electronics 34 which provide control signals to HDA 32, receive data signals from and transmit data signals to HDA 32, and interface the disk drive 30 with a host system. The host system may be, for example, a personal computer configured in a tower or desk-top casing, or a portable or laptop computer.

HDA 32 includes a base 42 and a cover 44. A gasket 46 is provided between base 42 and cover 44 to establish a sealed (or controlled) environment between base 42 and cover 44. Cover 44 is secured to base 42 by a plurality of socket head screws 45 provided through bores 40a in cover 44 into threaded bores 40. Disk drive 30 does not utilize a breather filter, and the seal provided by gasket 46 isolates the sealed environment from ambient atmospheric conditions and pressures. The seal provided by gasket 46 is stable at pressures experienced at altitudes from 200 feet below sea level to 15,000 feet above sea level during operation of the disk drive.

The components provided in the controlled environment established by HDA 32 include disks 48a, and 48b, a spin motor 50 for rotating disks 48a-48b, an actuator assembly 52 for reading data from and writing data to disks 48a-48b, a header assembly 54 for

- 11 -

transferring electronic signals to and from the controlled environment established in HDA 32, and a latch assembly 56 for parking actuator assembly 52.

Control electronics 34 are provided on a printed circuit board (PCB) 58. Electronic elements 34 are provided on the bottom surface 58b of PCB 58. The control electronics 34 control the operation of spin motor 50, the operation of actuator assembly 52, and the transfer of data to and from disk 48. PCB 58 is mounted to base 42 and electrically grounded to the HDA 32. The dimensions of disk drive 30 are shown in Figures 1B and 1C, and Table 1.

The above-described basic structure of disk drive 30 provides protection from shock and vibration. In particular, disk drive 30 will withstand non-operating shocks on the order of 300g's and operating shocks, without nonrecoverable errors, of 10g's. Non-operating vibration of 5.0g's in the range of 10-400 Hz is the specified tolerable limit. Operating vibration, without nonrecoverable data, is specified at 0.5g's for the range of 10-400 Hz.

Header Assembly

With reference to Figures 1A-1C, the header assembly 54 will be hereafter described. Header assembly 54 couples PCB 58 to the internal components of drive 30 in the controlled region between base 42 and cover 44. Header assembly 54 electrically couples to flex circuit 160 to provide electrical connections to heads 60, 61, and actuator coil 85 mounted on rotating actuator arm 82. A spin motor flex circuit 190 is also electrically coupled to header assembly 54 to transfer motor control signals from PCB 58 to spin motor 50.

- 12 -

The main components of header assembly 54 are header 162, flex circuit bracket 164 and flex circuit 160. Header 162 includes copper connector pins 166 molded to a plastic base 167. Header 162 is press fit
5 into socket 168 in base 42. Bracket 164 has a base portion 168a and an arm portion 168b which secures a head signal pre-amp chip 170 and flex circuit 160. In general, head signal pre-amp chip 170 is coupled to second end 160b of flex circuit 160 prior to installing
10 the circuit in drive 30.

As shown in Figures 1B-1C, flex circuit 160 is a reverse flex circuit and is secured to actuator body 110 with a screw 162a in bore 162b to reduce the adhesive necessary to secure components in drive 20.
15 Pins 166 engage corresponding pin holes (not shown) on PCB 58.

Spin motor flex circuit 190 lies on the bottom of base 42 and is secured to three of the pins 166 on the bottom surface 42b of base 42 as shown in Figure 1B.
20 Flex circuit 190 is secured to base by an adhesive or a screw (not shown).

Actuator Assembly

Actuator assembly 52 (Figures 2-15) performs the
25 function of positioning heads 60a-d with respect to disks 48a-48b. An actuator coil 86 is mounted at a second end of actuator assembly 52. Actuator assembly 52 comprises actuator arm assembly 53 and bearing cartridge 90. Actuator arm assembly 53 is mounted on
30 base 42 on an actuator post 88 and bearing cartridge 90, is secured to and over actuator post 88. Actuator post 88 is provided through a bore 88a in base 42.

Figure 2 shows a perspective view of the first embodiment of an actuator arm assembly 53 suitable for

- 13 -

use in accordance with the disk drive of the present invention. Actuator arm assembly 53 is comprised of a plurality of head arm assemblies 56a-56d. The head/arm assembly is comprised of an arm plate 59, and a load beam 82 to which heads 60a-60d are attached. Each load beam 82 is welded to arm plate 59. This allows alignment of the load beam 82 and arm plate 59 to be performed prior to final assembly of actuator assembly 52. In addition, heads 60 can be aligned on load beam 82 and the load beam and head attached to arm plate 59.

Shown in further detail in Figure 3 are a spacer 84 and spacer/yoke 86. Spacer/yoke 86 serves as a spacer between arm assemblies 56c and 56d, a mounting surface for flex circuit 164, and a yoke for coil 85. Plate 116 on spacer/yoke 86 serves as the mounting surface for one end of flex circuit 160. Centralized bores 108a-108e are provided in arm plates 59, spacer 84, and yoke/spacer 86 to form a cavity 108 for receipt of bearing cartridge 90 after actuator arm assembly 53 has been assembled. Plate 116 is coupled to yoke/spacer 86 and serves as the mounting surface for flex circuit 160.

Each load beam 82 is spot welded to each arm 59. This operation may be out-sourced by a drive manufacturer to a suspension manufacturer. The welding process utilized to attach load beams 82 to arms 56 is the same process utilized to weld load beams to base plates in conventional suspensions. Load beams 82 are, for example, type 14 manufactured by Hutchinson, having down facing rails. Flexures on the respective load beams support respective ones of head 60a-60d. In addition, attachment of the read/write head to the load beam is an operation which may be out-sourced, so that each head/arm assembly 56 is received from a vendor in

- 14 -

an assembled condition including head 60, load beam 82 and arm plate 59, thereby suitable for installation into a disk drive. Each head/arm assembly 56 may be positioned so that arm plates 59 are flush with respect to each other (as in arms 59b, 59c) or the mounting surfaces of yoke spacer 86 (as in arms 56c, 56d) and spacer 84 (arms 56a, 56b). Alternatively, a second spacer 91 may be placed between plates 59b, 59c which tends to reduce vibration in the head arm assembly. Spacer 91 is on the order of 0.014" thick. Actuator bearing cartridge 90 is sized to be inserted into bore 108 in arm assembly 53. A lock collar 123 (Figure 5) secures actuator arm assemblies 56a, 56b, 56c, and 56d, by sandwiching plates 59a, 59b, 59c, 59d between lock collar 123 and a lip 103 on outer member 102 of bearing cartridge 90. As discussed in detail below, bores 108a-108d allow plates 56a-56d to slip over a precision arbor 414 on a pallet during the assembly process. Actuator arm assembly 53 is thereafter secured by the bearing cartridge, and/or a fastener, as discussed below.

As shown in Figure 1D, bearing cartridge 90 includes inner member 96, bearings 104,106, outer member 102 and lock ring 123. Inner member 96 slips over actuator post 88 and has a mounting surface 98 which interfaces with top surface 100 of post base 92. Outer member 102 of bearing cartridge 90 is rotatably mounted about inner member 96 by first and second bearings 104, 106.

Inner member 96 and outer member 102 are generally manufactured from 300 Series stainless steel. Bearings 104,106 are lubricated with a 40 micron filtered Nigrace grease, and the inner rail thereof is affixed to the inner member 96 the application of a high

- 15 -

strength cured adhesive, such as Loctite 661N. Outer member 104 includes a lip 103 around the circumference thereof which is utilized to secure the assembled bearing cartridge 90 in bore 108 of arm assembly 53 after bearing cartridge 90 is fit into bore 108. A spacer 124 and lock ring 123 secure actuator bearing cartridge 90 in arm assembly 52 and secure head/arm assemblies 56a-56d from vertically separating. As shown in Figure 1C, lip 103 engages the top surface of head/arm assembly 56a as bearing cartridge 90 is placed in hole 108. Spacer 124 is inserted over cartridge 90 and engages the bottom surface of head/arm assembly 56d. Lock ring 123 engages notch 125 in cartridge 90 when cartridge 90 is mounted in bore 108, and secures arm assembly 53 between lip 102a and spacer 124. A well region 64 is provided in base 42, to allow for maximum stiffness of base 42 but provide sufficient clearance for head/arm 56d and head 60a on the lower surface of disk 48a.

A unique feature of the actuator arm assembly 53 is the manner in which the individual head/arm assemblies 56 are secured. Each arm plate 59 includes a leaf spring 63 which engages a mounting post 111 and retains each head/arm assembly 56 in a secure, fixed position. Leaf spring 63 also provides for a novel method of assembly of actuator assembly 52. As shown in Figure 4, leaf spring 63 includes a notch 112 which engages shaft 111 and, in conjunction with the force of leaf spring 63 away from bore 108, secures each head/arm assembly 56 with respect to spacer/yoke 86. Consequently, no fasteners, other than clip ring 123, need be used to secure actuator assembly 52. Naturally, the position of arm assemblies 56a-56d relative to spacer/yoke 86 is the most significant

- 16 -

positional relationship; if all head/arm assemblies 56 are secured against rotation out of alignment with respect to yoke/spacer 86, the rotational alignment of heads

5 60a-d in actuator assembly 52 will be maintained when actuator arm 53 rotates under the force induced in coil assembly 85.

One end of leaf spring 63 is coupled to arm plate 59, while the second end includes a beveled lead edge
10 113. Edge 113 of leaf spring 36 is beveled so that, during the assembly operation, the leaf spring will flex toward the center of bore 108 and allow mounting post 111 to slip into notch 112.

Figure 5 represents an alternative embodiment of
15 actuator assembly 52 including actuator arm assembly 53-1 wherein head/arm assemblies 56a-1, 56b-1, 56c-1, and 56d-1 all include additional through bores 114a-d, 115a-d which may be utilized to secure head/arm assemblies 56a-1 through 56d-1 against lateral rotation
20 through the use of fasteners, rather than through the leaf spring and post arrangement of assembly 53. A feature of the second embodiment of the actuator arm assembly 53-1 is that fasteners 118a, 118b are used to prevent rotation of the head/arm assemblies with respect to each other. Each fastener 118a-b may each
25 comprise a threaded bolt coupled to a nut 119a-b. As discussed below, fasteners 118a-b allows actuator arm assembly 53 to be rotated so that heads 60a-d are aligned, with fasteners 118a-b thereafter securing
30 head/arm assemblies 56a-1 through 56d-1 of actuator arm assembly 53-1 prior to insertion of bearing cartridge 90. Fasteners 118a-b serve to retain the alignment of the head/arm assemblies. Vertical retention of the

- 17 -

actuator arm assembly is provided by clip ring 123 and lip 103.

5 A second variation of the second embodiments shown in Figure 5 is the relative placement of spacer/yoke 86-1 and spacer 84-1. As will be noted therein, the respective positions of these two elements have been reversed with respect to the assembly shown in Figure 3, as a matter of design choice. Placement of the spacer/yoke and arm spacer is a design choice dependent
10 on the structure of the spacer/yoke, the number of arms, the size of the actuator coil and the magnet structure, and the thickness and number of permanent magnets utilized in the voice coil motor assembly.

15 Assembly of the Actuator

The aforementioned embodiments structure of actuator assembly 52 provide a unique and cost-effective method by which to manufacture the actuator in an automated process. This allows synchronization
20 of manufacturing of the actuator assembly at a point in time during the overall manufacturing process of the disk drive which is concurrent with the assembly of the disk drive architecture as a whole. This results in a reduction of contaminants in the disk drive since
25 assembled actuators need not be provided from a second source vendor, and have less opportunity to accumulate contaminants during the shipping and manufacturing process. Furthermore, the drive manufacturer can maintain more accurate control over the environment in
30 which the actuator assemblies are maintained. Secondly, less time expires between completion of the actuator assembly process and the placement of the assembled actuator into a contaminant-free environment within the drive.

- 18 -

A still further advantage is the fact that the drive manufacturer has an opportunity to inspect and test head/arm assemblies 56, provided from the out-source vendor, prior to their assembly into a completed head stack. Traditionally, the out-source vendor supplies an assembled actuator with the heads, load beams, and E-block attached and aligned by the vendor. If inaccuracies exist in the component, there is no opportunity to correct these problems. The actuator assembly of the present invention allows the drive manufacturer to maintain better accuracy in terms of the gram loads, static attitude (pitch and roll) of the heads, flexures, and mounting plates used in the actuator by testing the head/arm assemblies prior to construction of the actuator.

Figures 6A, 6B and 6C illustrate fabrication of actuator arm assembly 53-1. The elements of actuator arm assembly 53-1 on a precision arbor 414 provided on a base member such as a pallet 412. Each head/arm assembly 56, spacers 84, 91 and spacer yoke 86 is stacked in the arrangement shown in Figures 3 or 5 on the arbor. Head/arm assemblies 56a-1, 56b-1, 56c-1 and 56d-1 are stacked out-of-alignment so that heads 60a-60d do not have the opportunity to contact each other and cause damage to the head or the head/arm assembly. It should be noted that bores 114, and notches 115 will not be aligned at this point. Build comb 117 is then inserted between the head/arm assemblies 56a-1 and 56b-1, and 56c-1 and 56d-1 to prevent heads 60a, 60b, and 60c, 60d, respectively, from coming into contact with each other and thus being damaged. After the head/arm assemblies 56a-1 through 56d-1 are stacked in the out of alignment arrangement shown in Figure 6A, comb 117 is moved to a position closer to heads 60a-d to ensure

- 19 -

that heads 60a-d do not come into contact with each other. Head/arm assemblies 56a-1-56d-1 are then rotated into a position shown in Figure 6B where heads 60 form a vertically aligned stack. Finally, fasteners 118a-b and nuts 119a-b are secured in bores 114 and notches 115 to retain head/arm assemblies 56a-1 through 56d-1. Optimally, as shown in Figure 6C, fasteners 118a-b have been previously loaded into nests in pallet 412, and are pneumatically driven through arm assembly 53 from the bottom toward the top of the assembly. Nuts 119a-b are installed from above to secure bores 114 and notches 110 to retain head/arm assemblies 56a-1 through 56d-1.

Where head/arm assemblies 56-1 are provided from an outside source vendor, such vendor welds each of load beams 82 to a corresponding arm plate 59, and attaches the head 60 to a flexure on the load beams. Each head/arm assembly 56 is manufactured within tolerance specifications provided by the disk drive manufacturer. These specifications can include the following: gram load, pitch, static attitude, head gap, tensile strength of the load beam, and head size. However, in the event that such tolerances are not met, the manufacturer has the opportunity to test the head/arm assembly prior to its incorporation in the actuator arm assembly. This allows the manufacturer to achieve a flying height for the heads which varies within a range of $\pm 0.75 \mu$ ", as opposed to the $1-2 \mu$ " variance currently anticipated. It should be noted that the orientation of load beams 82 with respect to arm plates 56 alternate between upper leaf facing sliders 82b, 82d and downwardly facing sliders 82a, 82c, as shown in Figure 4B. It should be noted that each arm plate 59, in the embodiment shown in Figure 3, must

- 20 -

have the same orientation in order for leaf spring 63 to engage shaft 111.

5 Fabrication of the first embodiment of actuator assembly 52, utilizing actuator arm assembly 53, is similar to the method for assembling the second embodiment of the actuator assembly, described above. Again, a pallet having a precision arbor is used as the assembly surface. The assembly process will be described with reference to the relative positioning of
10 the spacers/yoke 86 and spacer 84 shown in Figures 2 and 3.

Head/arm assembly 56d is first placed onto the arbor 414. Thereafter, the yoke/spacer 86 is slid over arbor 414. Yoke/spacer 86 includes plate 116 which
15 serves as a mounting surface for the portion of flex circuit 160 which will couple the drive electronics to electrically conductive read/write head lead wires. In the preferred embodiment of the assembly method of the disk drive, the actuator flex circuit will be pre-
20 attached to plate 116 by a suitable method such as the use of adhesives, a non-adhesive fastener, or welding. In addition, coil 85 will be attached to yoke/spacer 86, and the ends of coil 85 will be electrically coupled to the flex circuit 160 by, for example,
25 soldering the coil wires to terminal pads on the flexible circuit. Pre-amp chip 170 is also attached to flex circuit 160 prior to attachment of flex circuit 160 to plate 116. Again, the attachment of the actuator flexible circuit 166 to plate 116 may be performed by
30 the outside vendor. Again, the specifications of flexible circuit 160 and the manner in which it is attached to mounting plate 116 will be specified by the disk drive manufacturer. Flex circuit 160 is preferably attached prior to assembly of actuator arm

- 21 -

assembly 53, and second end 160b of flex circuit 160, which is not attached to plate 116 and which will be coupled to header assembly 54, is held out of contact with head/arm assemblies 56 during the actuator arm assembly process.

5
10
15
20
Subsequently, head/arm assembly 56c will be placed on top of yoke/spacer 86. It will be noted at this point that leaf springs 63a-63d, notches 112, and shaft 111 are not in engagement when the head/arm assemblies are placed onto the arbor. Thus, shaft 111 is held at a position which is clockwise rotated with respect to leaf spring 63 on each of the head/arm assemblies. Further, head/arm assembly 56c is rotated with respect to actuator arm assembly 56d to avoid contact between heads 60d and 60c. Because the head/arm assemblies are placed in the arbor at different positions, the distance between each notch on springs 63a-63d and shaft 111 will vary. After assembly 56c is mounted on arbor 414, spacer 91, head/arm assembly 56b, spacer 84, and head/arm assembly 56a are sequentially provided on the arbor.

25
30
As with the assembly process shown in Figure 6A, a build comb 117 is thereafter placed into the gaps between arms 82a and 82b, and arms 82c and 82d, respectively. Subsequently, head/arm assemblies 56 are rotated into a position where heads 60a-d are in vertical alignment along an axis A as shown in Figure 6B. When heads 60a-60d rotate into alignment, leaf springs 63a-d rotate clockwise with respect to spacer/yoke 86, which is held stationary, with a force sufficient to allow bevel edge 113 to bend leaf spring 63 toward arm 59 until notch 112 engages shaft 111. The head/arm assemblies will thus be secured against rotation relative to each other and spacer/yoke 86.

- 22 -

Once clamped by actuator bearing cartridge 90 and lock ring 123, arm assembly 53 is secured. A load or shipping comb is then positioned at the front end of the stack and remains there while actuator assembly 52
5 proceeds to installation of bearing cartridge 90.

After the actuator arm assembly 53 is completed, bearing cartridge 90 may be installed. Installation of the bearing cartridge is generally performed manually by inserting the bearing cartridge through bore 108,
10 and attaching spacer 123 and clip ring 124. During this process, the comb remains separating the heads so that no damage to the heads results during handling.

In an alternative bearing cartridge design, lip 103 may be provided at the base of bearing cartridge 90, with lock ring 123 at the top. In this embodiment,
15 outer member 102 is essentially reversed from top to bottom and may be secured on the base plate prior to installation in the actuator arm assembly. This alternative advantageously allows for the actuator
20 assembly to be assembled directly on base plate 42 of the drive. In such case, actuator post 64 would be attached in base 42, and bearing cartridge 90, in the inverted embodiment previously described, mounted thereon. Thereafter, the head-arm assemblies, spacer
25 and spacer/yoke are placed over the bearing cartridge. The assembly can then be rotated and secured in accordance with the first or second embodiment of actuator arm assembly 53.

30 Voice Coil Motor And Latch

The force necessary to pivot actuator arm 82 is created by a voice coil motor including coil 85 and a magnet structure 130 shown in Figures 1A, 1B. Magnet structure 130 includes two neodymium-iron-boron bipolar

- 23 -

magnets 132,133, top and bottom plates 134,136, support posts 138,140 and latch post 142. Bipolar magnets 132,133 are secured to top and bottom plates 134,136, respectively. First and second support posts 138,140 and a bifurcated latch post 142, support top and bottom plates 134,136. Top and bottom plates 134,136 are manufactured from 12L14 steel with an electroless nickel finish. Bores 126 and 128 are provided in each of top plates 134 and bottom plate 136 which allow support posts 138,140 to be secured therein. Support post 138 is manufactured from AISI 17-4 stainless steel. Support post 140 is manufactured from 12L14 steel, with an electroless nickel finish, with 5-8% phosphorous. Latch post 142 is likewise manufactured from 17-4 stainless steel. Thus, posts 138,140 and 142 are magnetically permeable and function as returns for the magnetic fields provided by magnets 132,133 and form a circuit which channels flux to latch post 142. It is important that there are no air gaps between posts 138, 140, 142 and top and bottom plates 134, 136; any air gap would create a discontinuity in the magnetic return, greatly reducing the strength of the magnetic fields in the circuit. This combination of magnetically permeable material in top plate 134, bottom plate 136, support posts 138, 140, and latch post 142 creates a magnetic circuit flux path through these elements that allows efficient utilization of the magnetic field of magnets 132,133 to latch the actuator during parking, as described below.

Magnet structure 13 and actuator coil 85 are arranged so that coil 85 is placed in the magnetic fields created by magnet 132. Currents passing in coil 85 create torques so that actuator arm 82 may be

- 24 -

pivoted to position heads 60a-d at selected locations with respect to disks 48a-b.

Actuator assembly 52, including all of the components attached thereto, is precisely balanced, i.e., equal amounts of weight are provided on either side of pivot axis 89 so that the pivoting of actuator arm assembly 53 to position heads 60a-d has a low susceptibility to linear shock and vibration. Actuator assembly 52 provides average access times of less than 20 milliseconds, and averaging 12ms, due to the high power-to-mass ratio and the small moment of inertia of actuator arm assembly 53.

An outer diameter crash stop is provided to limit the pivoting movement of actuator arm 82 so that heads 46 travel only between the landing zone 150 and outside data diameter OD of each disk 48a-b. A landing zone (or non-data area) 150 (shown in Figure 1B with respect to disk 48a) is located, e.g., adjacent to the inside diameter ID, and actuator assembly 52 positions the heads 60a-d over landing zone 150 during parking. The landing zone 150 may be any selected portion of the disk; however, a portion of the disk adjacent to the ID or OD is usually selected.

The outside diameter crash stop is provided by an O-ring 152 of EPDM which fits over actuator post 140 formed therein. When the pivoting motion of actuator arm 82 places heads 60a-d at the OD of disks 48a-b, the edge of yoke/spacer 63 contacts O-ring 152 serving as the outside diameter crash stop. The inside diameter crash stop is provided by the latch mechanism and is described below.

A latch mechanism is utilized to lock actuator assembly 52 in a position where heads 60a-d are located over landing zone 150 of disks 48a-b and will be

- 25 -

described with reference to Figures 1B, 1C. The latch assembly includes a latch pin 174, mounted in a bore 105 molded into spacer/yoke 86, an O-ring 176, and latch post 142.

5 As described above with respect to magnet assembly 130, the flux generated by actuator magnets 132,133 is directed in a magnetic circuit which includes latch post 142. Latch post 142 includes a ring 142a defined between portions 144a and 144b of post 142 which causes
10 the flux incident from magnets 132,133 to be directed therethrough. Latch pin 174 is manufactured from type 17-4 stainless steel. Pin 174 contains a detent region (not shown) so that only the outer circumference of the pin face engages ring 142a. When pin 174 is brought
15 into contact with post 142, the magnetic flux about ring 142a passes through pin 174 and secures pin 174 to post 142 as pin 174 becomes part of the magnetic circuit formed by magnets 132, 133, latch post 142, top plate 134, bottom plate 136, and support post 138.
20 This interaction force is sufficient to restrain movement of actuator assembly 52 under the environmental conditions specified below to ensure an adequate latching force. In the prior art, latch pins were required to squarely engage a latch body so that
25 no air gaps existed between the face of the pin and the magnetic returning body. In the latch of drive 30, the rounded shape of ring 142a eliminates the concern over the squareness of the engagement between pin 174 and ring 142a. There is sufficient contact area such that
30 the latch mechanism secures the actuator assembly under the conditions as specified below. An additional feature of this latch assembly is that no additional latch magnet is required to restrain the actuator in the latch position. The power of the voice coil motor

- 26 -

assembly is sufficient to overcome a latching force when a strong current is applied to coil 86.

Head Wire Carrier

5 Figures 7-16 show various embodiments of a head wire carrier suitable for use in accordance with the assembly of the actuator and the disk drive of the present invention.

10 Figure 7 is a perspective view of a first embodiment of the head wire carrier 200. Figure 7 shows a first end portion of flex circuit 160 attached to flex circuit bracket 116 of spacer/yoke 86. A single actuator arm 59 is shown abutting spacer/yoke 86; for simplicity, load beam 82 and head 60 are not shown. Figures 8A-8C are side, top, and sectional views of the first embodiment wire carrier 200.

15 Wire carrier 200 attaches to actuator arm 59 by means of molded tabs 201, 202, 203, and allows for accurate positioning of head lead wires 210 and 212 over solder pads 262, 264 of flex circuit 160. Head lead wires 210 and 212 are coupled to head 60 to carry data read/write signals to and from head 60.

20 Lead wires 210,212 are encased in a 0.012 inch diameter Teflon tube insulation 211; the insulation ends where the leads are exposed to make electrical contact with termination pads. Prelocating of the head lead wires over the solder pads of the circuit 160 allows for the use of an automated reflow soldering processes to couple the head lead wires to the flex circuit leads. This can result in considerable cost savings to the drive manufacturer as well as an increase in the speed of the process for manufacturing disk drives. In prior art manufacturing processes, assembly of the head wire leads to the flexible circuit

25

30

- 27 -

would require manual soldering of the head wire pairs to respective solder pads. This means that a human worker would be required to manually align each wire lead and solder the lead to the head pad. The placement of head wire carrier 200 on each arm 59 effectively eliminates the human element at this stage of manufacturing process of the actuator. As will be explained in further detail below with respect to additional embodiments, head wire carrier 200 has an extended position and a retracted position. The retracted position is shown in Figures 7 and 8. In the retracted position, window 206 of wire carrier 200 is closely adjacent to arm plate 59 and the head lead wires 210, 212, are positioned adjacent to flex circuit 160 and therefore may be attached thereto by use of reflow soldering. A soldering device suitable for this purpose is the HTT1000, manufactured by Hughes Aircraft Corp. In an extended position, as shown by a first alternative embodiment 200-1 in Figure 10), window portion 206 of head wire carrier 200 rotates about the axis defined by tabs 201 and 202 (or, in embodiments 200-1, 200-2, about lock pin 207, in a clockwise position relative to Figure 8B) to allow head arm assembly 56 to be assembled into actuator assembly 52 without interfering with the position of actuator flex circuit 160 mounted to plate 116 of yoke/spacer 86.

Figures 9, 10, 11, and 12 illustrate perspective views of a second embodiment of head wire carrier 200-1 attached to arm plate 59. It should be recognized that the orientation of head wire carrier 90 relative to arm plate 59 can be reversed so that head wire carrier 200 or 200-1 can be utilized on either side of arm plate 59 depending on the design requirements of the storage device. Head wire carrier 200-1 includes a lock/tab

- 28 -

208 and pin 207 which secure head wire carrier 200 between upper shelf 209 and plate 220. In the retracted position, shown in Figure 9, each wire carrier 200-1 is secured to each arm plate 59 by a lock tab 208 which engages surface 57 of arm plate 59. In the extended position, shown in Figure 10, pin 207 remains secured in arm plate 59 and carrier 200-1 is rotated about pin 207 to allow flex circuit 160 and mount plate 116 to be inserted between window 206 and arm plate 59. As shown in Figure 12, a wire mount member 222 is positioned on one side of wire carrier 200-1 to allow routing of head lead wires, such as wires 210 and 212, in the notches formed at ends 222-1, 222-2, and through slots 224-1 and 224-2, to precisely locate and secure the respective head lead wires in window 206.

Figures 13-16 show another alternative embodiment of a wire carrier 200-2 which comprises a flexible strip retainer, having two window regions 222 and 224 to pre-locate head lead wires 210 and 212 over solder pads 262, 264. As shown in Figure 14, wire carrier 200-2 is fabricated so as to be folded across a fold line B in Figure 14 so that the head wire pairs, such as head wires 210, 212, are contained between sides 214, 215 at the interior of the folded member. The folded member is then secured to arm 59 or by an adhesive or other means.

The wire carrier of the present invention provides the distinct advantages of facilitating the use of reflow solder and a completely automated actuator and drive assembly process. In addition, wire carrier 200 also allows for the use of a solderless coupling between the head lead wires and the flex circuit which greatly reduces the amount of contamination in the

- 29 -

drive and improves the ease with which both the actuator assembly and the drive as a whole can be assembled.

5 Figure 16A shows a first embodiment of a solderless wire coupling in accordance with the present invention. Shown therein is an adapter block 206a which may be inserted into window 206 of wire carrier 200 or 200-1. In this embodiment, lead wires 210 and 212 are placed in channels 226 and 228. A drop of
10 conductive electrical gel 230, 232, which may comprise a conductive silicone polymer connector such as that manufactured by Amp Electronics, is suitable for use in this embodiment. Optionally, a corresponding drop of gel can be placed opposite a modified flex circuit.
15 The conductive gel is potted into cups (not shown) in the carrier, the cups having a half-spherical shape and sized to receive drops 230, 232. The gel is placed in the cups, around the wire ends, and then cured. Alternatively, the wire ends are laid over the
20 conductor gel after curing as in Fig. 16A. Block 206a is then placed in wire carrier 200-1 and the carrier attached to arm plate 59. Preferably, head lead wires 210 and 212 secured in grooves 226, 228 with drops 230, 232 conductive gel applied thereto and provided to the
25 disk drive manufacturer by the head arm assembly out-source manufacturer. After block 206a is placed in wire carrier 200 or 200-1, the assembly of the actuator arm assembly 53 proceeds in accordance with the above description. Once the actuator arm assembly 53 is
30 secured, each carrier 200-1 and the wire leads with conductive gel 230, 232 is pressed against flex circuit solder pads 262, 264. The solderless coupling assembly facilitates automation of this final manufacturing step as head lead wires 210, 212 and flex circuit pads

- 30 -

262,264 are pre-located in alignment by the head wire carrier 200, without the use of contaminant elements in the attachment process. Of particular concern with this embodiment of the solderless coupling where a
5 conductive gel is used are the electrical characteristics, and the outgassing qualities of the conductor gel. Care must be taken to ensure that the selection of a conductive gel is one which does not provide additional contaminants into the drive at
10 unacceptable levels over the life of the drive.

A second alternative manner for using the solderless, conductive gel to couple the head lead wires to the flex circuit is shown in Figure 16B wherein a third embodiment of wire carrier 300-3
15 includes grooves 226a, 228a formed directly into carrier 200-3, and conductive gel 230,232 applied directly thereto.

Another embodiment of a solderless wire coupling assembly suitable for use with the wire carrier of the
20 present invention is shown in Figures 17A, and 17B. Figure 17A is a side view and Figure 17B a top view of a plug-in connector 240, including conductor pins 242 and 244, which are coupled to head lead wires 210 and 212, respectively. The pins are mounted to a bracket
25 248 which can be secured to arm plate 59 by placing the square receptacles 252 and 254 in bracket 248, and mounting fingers 249 and 250 through receptacles 252 and 254. As shown in Figure 17B, flex circuit 160 is provided with through holes 266,268, and flex lead pads
30 270,272. Lead pads 270,272 are electrically coupled to pins 242,244, and hence wires 210,212, by surface mount solder tabs 274 and 276 coupled to sockets 275 and 277, respectively, on socket housing 246. Socket housing 246 is preferably adapted to be secured to one of the

- 31 -

aforementioned embodiments of the wire carrier. When the assembly is fitted together, flex circuit 160 is sandwiched between housing 246 and arm plate 59, bringing pads 270,272, tabs 276,274, and pins 242,244 into engagement, thereby electrically coupling wires 210,212 to flex circuit 160.

Figures 18A and 18B are top and side views, respectively, of another embodiment of a solderless lead connector suitable for use in accordance with the wire carrier of the present invention. As shown therein, a side rail 290 is provided on arm 59. Side rail 290 is bent to form a right angle with respect to the major surface portion of arm plate 59. Head arm wires 210,212 are coupled to a flex tab assembly 295 which includes terminal pads 296 and 298. Flexible tab 295 can be adhered to rail 290 by the use of pressure sensitive adhesive backing material, such as part no. Y966, manufactured by the Minnesota Mining and Manufacturing Corporation (3M). Details of flexible pad 292 are shown in Figure 18D. Flexible pad 292 is comprised of polyamide flexible printed circuit pad, with contacts 296,298 comprising copper pads provided less than 0.0005 thick gold plating.

A contact carrier subassembly 300 includes two snap-in fasteners 302 and 304 which secure contact carrier 300 to flexible circuit 160. In this embodiment, flexible circuit 160 is provided with three contact pads 306, 307, and 308 which electrically couple wires 210,212 provided in flexible circuit 160 to corresponding contacts 309, 310, 311 on contact carrier 300. A backing stiffener 310 is provided to secure flex circuit 160 to contact carrier 300. Contact carrier 300 also includes contact pins 312, 314, and 316. Contacts 314,316 engage pads 296 and

- 32 -

298, as shown in Figure 18C. Pads 309, 310, 311, 314,
and 316, are microconnectors such as those manufactured
by the Cinch Company and marketed under the name
"CIN::APSE" Button Contact Carrier. As shown in Figure
5 18C, the contact carrier 300 is secured through holes
318,320 in flex circuit 164 to stiffener 310 forming
the contact carrier subassembly. This subassembly can
then be secured to bore 292 by contact 312 flexible tab
290 coupled to head lead wires 210,212. The contact
10 and retention of the contact carrier subassembly with
pads 296,298 is assured through the adhesive forces of
the button contact connectors.

Once the carrier subassembly is formed, as shown
in Figure 18C, the contact carrier 300 is secured to
15 arm 59, and specifically rail 290, by compressing
contact 312, 314, 316 against contacts bore 292, on
rail 290, and pads 296,298 on flex tab 295. It should
be readily recognized that stiffener 310 may comprise
a portion of the wire carrier 200,200-1, in accordance
20 with the teachings set forth above.

Figures 19A and 19B show yet another alternative
embodiment of solderless electrical connectors fused
with the wire carrier of the present invention. Figure
19A is a side view of the head arm and flex tab, while
25 Figure 19B is a top view of the coupling assembly.
Contact carrier 330 includes two contact buttons 332
and 334 similar to those represented with respect to
contact carrier 300. A ground connector 336 is also
provided with a pointed end 337 which will engage
30 through hole 292 in tab 290. Flexible tab 295 are
equivalent to that shown and described with respect to
Figure 18, arm tab 290, and bores 294,295. Flexible
circuit 160, in this embodiment, is provided with
compression connectors 340, 342 and 344 which engage

- 33 -

contacts 333, 335 and 337 on contact carrier 330. A backing stiffener 350, which may again comprise a portion of the head wire carrier 200, 200-1, is adhesively secured to the flex circuit 160. In
5 assembly, stiffener 350 is forcibly applied against the contact carrier pads, ground pin 336 engages through bore 297 and secures contact carrier 330 against flex pad 295 so that contacts 334 and 332 engage lead wires 210,212. Compression contact connectors 340, 342 and
10 344 engage contacts 333, 335, and 337, thereby securing the flex circuit against the contact carrier and forming an electrical connection between the head lead wires and the flexible circuit.

Figures 20A and 20B show two variations of a
15 fourth embodiment of a solderless contact carrier in accordance with the present invention. Figure 20A is an exploded view and Figure 20B an assembled view of the solderless assembly. Flex circuit 160 in this embodiment, is mounted to a receiving member 360 which
20 includes tabs 362 and 364. As noted in Figure 20A, receiving member may be one of two lengths--the long version of member 360 is reflected by solid tab 362 on arm 361, and dashed tab 364-1 on arm 363-1. Compression connectors 366,368 are provided on flex
25 circuit 164. Head wire carrier 370 includes two wire pins 372,374 which may be pre-soldered to head lead wires 210 and 212. Main block 380 includes detents 381,382 which engage tabs 362,364. Arm 59 includes two lock arms 376,378, which engage wire holder 370 to
30 secure carrier 370 against arm plate 59.

An alternative embodiment of carrier 370 includes detent regions 381-1, 382-2 on arms 384,386 formed onto the side of main body portion 380 of the carrier. In this embodiment, the "short" version of member 360 is

- 34 -

used and tabs 362 and 364 align with regions 381 and 382 and form a snap fit. Arms 384,386 align with inserts 388,390 in arm plate 59. The assembled head arm contact assembly is shown in Figure 20B, with the first, short alternative embodiments shown in solid form on the right side of the figure, and the second, long version shown on the left side of the figure and in dashed form on the right side of the assembly.

Figures 21A and 21B are a side view and top view, respectively, of another alternative of a solderless wire coupling suitable for use with the wire carrier of the present invention. Flex circuit 160 has a cover 391 attached thereto which is attached to arm assembly 56. Cover 391 includes through bores 392 and 393 which are adapted to receive locking posts 394-1, and 394-2. Locking post 394-1 and 394-2 are coupled to a spring connector assembly 395 which includes two spring connectors 396-1 and 396-2 and contact retainer 398. Head wires 210 and 212 are coupled to a support member 397 and secured to head wire carrier 200-3. Each wire 210, and 212 is adapted to have a wire interface pad 399-1, and 399-2 which is preferably plated with gold and which interfaces with a first side of spring connectors 396-1, 396-2. Flex circuit 160 engages another one side of contacts 396-1, 396-2 at points 399-1, 399-2. Lock post 394-1 and 394-2 are provided through bores 392 and 393 so that the upper portion of each post 394-1 and 394-2 passes through bores 392 and 393 and are shifted to the left, in the orientation shown in figure 21b, to lock cover 391 to assembly 395. This will allow s-contacts 396-1 and 396-2 to engage the wire interfaces 399-1, and 399-2 and flex interfaces 393 and 394. Figure 21B shows an embodiment where the terminal pads of flex circuit 160 are

- 35 -

arranged to connect to the opposite side of the circuit from their orientation shown in previous embodiments. The circuit traces are generally oriented on the top portion of the circuit, as shown in Figure 21B, and circuit 160 must be adapted to engage spring connectors 396-1, 396-2.

An alternative cover 391a is shown in Figure 21C wherein flex circuit 160 wraps around cover 391a, with additional through bores provided in flex circuit 160 at locations corresponding to through bores 392, 393. This allows the flex circuit conductive wires to be oriented correctly with respect to the terminal pads on the flex circuit 160 as shown in previous embodiments.

It should be readily recognized that any number of suitable soldered or solderless type connector assemblies may be prepared in accordance with the teachings of the present invention. The wire carrier of the present invention provides an automated solution to the problem of attaching the head arm lead wires 210, 212 to the solder pads or other suitable connector on the flex circuit.

Actuator And Disk Drive Assembly

The aforementioned features of the architecture of the disk drive for the present invention allow for an automated assembly process to be utilized to assemble the components of the disk drive. Using an automated assembly process reduces the contamination, human error, and therefore increases the drive production yield which can be attributable to manufacturing the disk drive in accordance with the method.

Figure 22 is an overview of an apparatus for assembling actuators incorporating actuator assembly 52 and various embodiments of the head wire carrier 200

- 36 -

described above. In the embodiment shown in Figure 22, the method is shown as a partially manual process including operations for four individuals indicated by reference numbers 1-4 at particular stages in the assembly process. It should be recognized that the human assembly element could be removed by automation.

Apparatus 400 includes part stacking conveyor 410 which is serviced by an individual shown at reference number 4. Individual number 4 places trays 415 of pre-manufactured head/arm assemblies 56 in a part stack 411 on conveyor 412 adjacent to drive line 450. A tester 420 is provided to pre-test all of the head/arm assemblies 56 which are to be installed in the disk drives. This tester determines whether the characteristics of gram load, head continuity, and static attitude (head pitch and roll) of each of the head/arm assemblies meet the design specification of the manufacturer to within acceptable tolerances. By testing all of the aforementioned factors of each of the head/arm assemblies prior to installation of the head/arm assemblies in the drives, increased accuracy in the flying height at the head disk interface and improved production yields can be achieved, since parts which do not meet the design specifications of the disk drive manufacturer are rejected prior to assembly into the actuator stack. A series of assembly pallets 412 is utilized to manufacture each of actuator assemblies 52. In the embodiment shown in Figure 22, pallets 412 are flat blocks of aluminum or acetal plastic with precision arbor 414 provided at the approximate center of the pallet. The pallets are passed along a conveyor line 450, for example, a Shuttleworth, "Slip-Torque" conveyor, from station to station.

- 37 -

Three automated assembly stations 430, 440, and 460 are provided. The automated assembly stations comprise stacking station 430, arm and coil rotation and fastener station 440, and solder station 460.

5 A particular pallet 412 is initially carried to stacking station 430 on conveyor line 450. Head/arm assemblies 56/56-1 are carried by presenter 425 to an automated head/arm manipulator 434. Head/arm assembly manipulator 434 positions the head/arm assemblies 56 on
10 arbor 414 at station 430 in the out of alignment arrangement described in accordance with the method for assembling the actuator 52 structure described above. A second manipulator, coil/spacer manipulator 432, places spacers/yoke 86, with coil 85 attached, and
15 spacers 84 on arbor 414. Manipulators 434,432 may be comprised of commercially available robotic components from THK America (linear motion actuators), Pacific Scientific (servo motors and amplifiers) and Motion Engineering, Inc. (servo controller system), with a
20 programmable control system adapted to perform the desired stacking procedures. Conveyor 442 is positioned below manipulator 432 to provide the assembly comprising spacer/yoke 86 and coil 85 to manipulator 432. It should be noted that flex circuit
25 160 is attached to plate 116 on yoke/spacer 86, coil 85 attached to yoke/spacer 86, and pre-amp chip 170 attached to end 160b of flex circuit 160. A belt conveyor 436 transfers spacers 84, 91 to manipulator 432. A lift assembly 444 is positioned under station
30 430 to lift pallet 412 off line 450, and rotate pallet 412 alternately clockwise and counterclockwise to allow the head/arm assemblies, coils and spacers to be stacked in the out-of-alignment arrangement. Once the parts are stacked on the pallet, the pallet

- 38 -

advances toward the rotation and fastener station 440. Manipulator 445, provided at station 440, rotates head arm assemblies into alignment, and installs fasteners 118a-b, 119a-b in accordance with the method described
5 above with respect to the second embodiment of the actuator assembly (Figure 5). Alternatively, where the actuator arm assembly 53, including the leaf spring and detent arrangement described with respect to Figures 2 and 3 is used, the fasteners need not be provided. The
10 shipping or load comb previously loaded to the pallet by individual number 1 remains between the respective actuator arm assemblies during the final stages of assembly to ensure the heads do not come into contact. Second end 160b of flex circuit 160 is held out of
15 contact with the balance of the head/arm assembly so that the flex circuit 160 does not interfere with fabrication of the actuator. However, the lead portion 160a of the flex circuit assembly is coupled to mounting plate 116 on spacer/yoke 86.

20 Once head-arm assemblies 56 are rotated into alignment and secured with respect to spacer 84 and spacer/yoke 86, by manipulator 445, the wire carriers attached to each head/arm assembly are rotated so that the head wire pairs are adjacent to the solder pads.
25 It should be understood that, where solderless carriers are used, this step brings the wire leads coupling assembly, mounted on the head wire carrier, into contact with the head wire assembly portion of the particular solderless assembly used on the head/arm
30 assembly.

Each pallet carrying the now-assembled actuator arm assembly 53 thereafter advances to a solder station 460 on line 450. At station 460, manipulator 455 attaches the eight head wire leads of the four heads

- 39 -

60a-d, through the use of reflow solder in accordance with the method described above regarding wire carriers 200, 200-1 and 200-2. The head wires may be attached to the head wire arms to the solder pads on the flex circuit 160 without human interaction, since the wires are prelocated over the solder pads. Where solderless connectors are utilized, this step can be eliminated as noted below.

Three manual assembly stations 470, 480, 490 are then provided.

Once the soldering operation is complete, pallets 412 advance to a human individual number 3, at station 470, who takes the second end of the flexible circuit 160 and wraps the flexible circuit about actuator assembly 52. Individual number 3 also installs a strain relief to maintain the flexible circuit 160 in a position about actuator assembly 52, suitable for installation into a disk drive. Each pallet then advances to individual number 2, at station 480, where bearing cartridge 90, spacer 124, and lock ring 123 are installed. Once this is completed, the assembly moves to individual number 1, at station 490, who transfers the assembled actuator assembly to a shipping tray, or transfer mechanism (for provision to the drive assembly). This individual then loads either a shipping or a load comb into a now-empty pallet. The shipping comb is utilized if the assembly is to be substantially transferred over a great distance. A load comb is utilized where apparatus 400 is integrated directly adjacent to drive assembly process. The load comb is then used to install the actuator over the disks 48 and the disk drive 30 of the present invention.

- 40 -

Where apparatus 400 is utilized to assemble actuator assemblies 52 directly on a base plate and modified actuator bearing cartridge 90, the need for shipping combs is eliminated.

5 Figure 23 is a representation of how the actuator assembly process represented in Figure 22 with respect to apparatus 400, in accordance with the architecture of the disk drive of the present invention, may be utilized in a method for manufacturing disk drives. As
10 shown therein, at step 501, the base plate is provided to the exact specifications of the disk drive manufacturer.

 After the lower portion of the magnet assembly has been attached to base 42, the spin motor flex circuit
15 is installed at step 504, and the spin motor secured to the base plate and spin motor flex circuit at step 506. Next, the head assembly is installed at step 508. As noted previously, the flex circuit is initially attached to spacer/yoke 86 and is not part of the
20 header assembly installed in base 42. Thereafter, the installation process will proceed by either installing the actuator at step 518, or building the actuator directly on the base plate in accordance with steps 520-530. At steps 510-519, the method of building an
25 actuator assembly in accordance with the apparatus shown in Figure 22 may be performed in synchronization with the disk drive assembly process 500 so that actuator assemblies are provided to the disk drive assembly
30 method as needed. At step 516, the assembled actuator assembly 52 may be provided to the assembly process 500, and the actuator installed at step 518.

- 41 -

Alternatively, at step 520, the actuator is built directly on the base plate in accordance with an alternative embodiment to the method described in accordance with apparatus 400. At step 520, the base plate is provided directly to apparatus 400 and bearing cartridge 90 secured on the base plate. It is noteworthy that the lower portion of the magnet assembly, the bottom plate and bottom magnet, were installed at step 520 on the base plate.

At step 522, head/arm assembly 56d-1 is placed over the bearing cartridge at a position where head 60d will align with the landing zone of disk 48b when the disk is placed on spin motor 50; spacer 84 is also placed on the actuator bearing cartridge at this time. At step 524, disk 60b is placed on spin motor 50, and the disk spacer placed on disk 60b. Next, at step 526, head/arm assemblies 56c-1 and 56b-1, sequentially, are placed on spacer 84. Again, the head/arm assemblies are arranged so that heads 60c, 60b will engage the landing zones on disks 48b and 48a. Spacer/yoke 68 is thereafter placed on head/arm 56b-1. At step 528, disk 46a is then placed on the disk spacer, and the disk 48a secured by the disk clamp. Finally, head/arm 56a-1 is secured on the stack, and the actuator stack coupled by clamp ring 123. At step 530, the spacer/yoke 68 is rotated and the actuator assembly fastened in accordance with the teachings presented herein. Next, the first end of flex circuit 160 is secured to the head wires by soldering or by the solderless wire coupling arrangements taught herein. At step 540, the second end of the flex circuit may be coupled to the pins of header assembly 54.

At step 545, the upper portion (the top plate and top magnet) of the magnet assembly are assembled onto

- 42 -

the bottom portion of the assembly. Finally, at step 550 the cover and gasket are installed to ensure a controlled environment between the base and the cover.

5 The many features and advantages of the disk drive of the present invention, and the method for assembling the disk drive of the present invention, will be apparent to those skilled in the art from the Description of the Preferred Embodiments and the Drawings. Thus, the following claims are intended to
10 cover all modifications and equivalents falling within the scope of the invention.

- 43 -

CLAIMS

What is claimed is:

1. An actuator assembly, comprising:
 - 5 a first actuator arm having a first end and a second end;
 - a second actuator arm having a first end and a second end;
 - a support member;
 - 10 a bearing assembly coupled to the arms and the support member and supporting the arms and support member for rotation about an axis, having a first portion abutting the first actuator arm and second portion abutting the second actuator arm, the first and
 - 15 second arms being secured against movement away from each other by the bearing cartridge; and
 - means for preventing rotation of the first actuator arm about said axis relative to the second arm.
- 20 2. The actuator assembly of claim 1 wherein the means for preventing rotation of the first actuator arms about said axis comprises first and second fasteners provided at opposite sides of the axis.
- 25 3. The actuator assembly of claim 1 wherein said means for preventing rotation comprises a leaf spring having a notch provided therein on the first and second actuator arms, and a fastener member provided on the
- 30 support member.
4. The actuator assembly of claim 3 wherein the notch in each leaf spring engages the fastener member to secure the actuator arms.

- 44 -

5. The actuator assembly of claim 1 wherein the first portion of the bearing assembly includes a lip, and the second portion of the bearing assembly comprises a clip ring and spacer.

5

6. The actuator assembly of claim 1 wherein the support member includes a coil assembly mounted thereon.

10

7. The actuator assembly of claim 1 further including a third actuator arm, a fourth actuator arm, and a second spacer, wherein the spacer separates the first and second arms, the second and third arms abut each other, and the second spacer separates the third and fourth arms.

15

8. An actuator, comprising:

a first actuator arm including a first retainer;

a second actuator arm including a second retainer;

20

a support member coupled to the first and second actuator arms and having a lock member;

a bearing assembly supporting the arms and the support member for rotation about an axis;

25

wherein the actuator arms are secured from rotation relative to each other by interaction between the first and second retainers and the lock member.

9. The actuator of claim 8 wherein the first and second retainers comprise a leaf spring.

30

10. The actuator of claim 9 wherein the leaf spring has a first end attached to the arm and a second free end, the second free end including a notch.

- 45 -

11. The actuator of claim 10 wherein the lock member comprises a dowel provided on the support member.

5 12. The actuator of claim 11 wherein the notch engages the dowel to retain the first and second arms.

13. An actuator assembly, comprising:

10 a first head arm assembly, including an arm body having a first end and a second end, the first end having a load beam attached thereto;

15 a second head arm assembly, including an arm body having a first end and a second end, the first end having a load beam attached thereto, the second head arm assembly positioned on a second side of the spacer element;

a spacer element positioned on one side of the first head arm assembly; and

20 a bearing cartridge, coupled to the first head arm assembly, and the second head arm assembly, with the first and second head arm assemblies being secured to each other and to the spacer element by the bearing cartridge and at least one fastener coupling each of the arm bodies from rotation relative to the spacer.

25 14. The actuator of claim 13 further including third and fourth head arm assemblies and a spacer/yoke assembly, the third assembly abutting the second assembly and the spacer/yoke assembly, the fourth head arm assembly abutting the spacer/yoke.

15. The actuator of claim 14 further wherein said at least one fastener comprises two fasteners coupled through each of the arm bodies.

- 46 -

16. An actuator assembly, comprising:

5 first and second head arm assemblies, each assembly comprising a mounting arm, a load beam and a read/write head, the load beam having a first end coupled to the mounting arm and a read/write head coupled to the second end, each assembly further including a leaf spring extending from the mounting arm;

10 a spacer positioned between the first and second head arm assemblies, the spacer including a post positioned such that the post engages the leaf spring when the head on each of the first and second head arm assemblies are in alignment; and

15 a bearing cartridge secured to the mounting plates and securing the mounting arms and the spacer.

17. A disk drive comprising:

20 a housing including an interior and an exterior, the interior having a disk mounting region and an actuator mounting region;

at least one disk mounted in the housing;

an actuator, comprising

25 a first integrated load beam and arm bracket,
a second integrated load beam and arm bracket,

a spacer positioned between the first and second integrated load beam and bracket,

a bearing assembly positioned in the arm bracket,

30 a fastener, coupled to the bearing assembly engaging the second integrated load beam assembly;

first and second data reading and recording heads;

and

- 47 -

control electronics means for controlling the actuator to position the heads with respect to the disk.

- 5 18. A disk drive, comprising:
 a housing;
 a storage medium mounted in the housing;
 a plurality of one read/write heads;
 an actuator stack positioned in the housing, the
10 actuator stack being comprised of a plurality of arms
 secured together about a bearing assembly, each arm
 having a first end at which one of the read/write heads
 is secured, each head having lead wires coupled
 thereto;
15 a wire carrier, positioned on each of the arms of
 the actuator stack, the wire carrier holding the lead
 wires;
 a controller directing the positioning of the
 heads by movement of the actuator stack, directing
20 movement of the spin motor, and directing reading and
 writing of data by the read/write heads;
 a header coupled to the controller; and
 a flexible circuit coupled to the header and the
 lead wires.

25

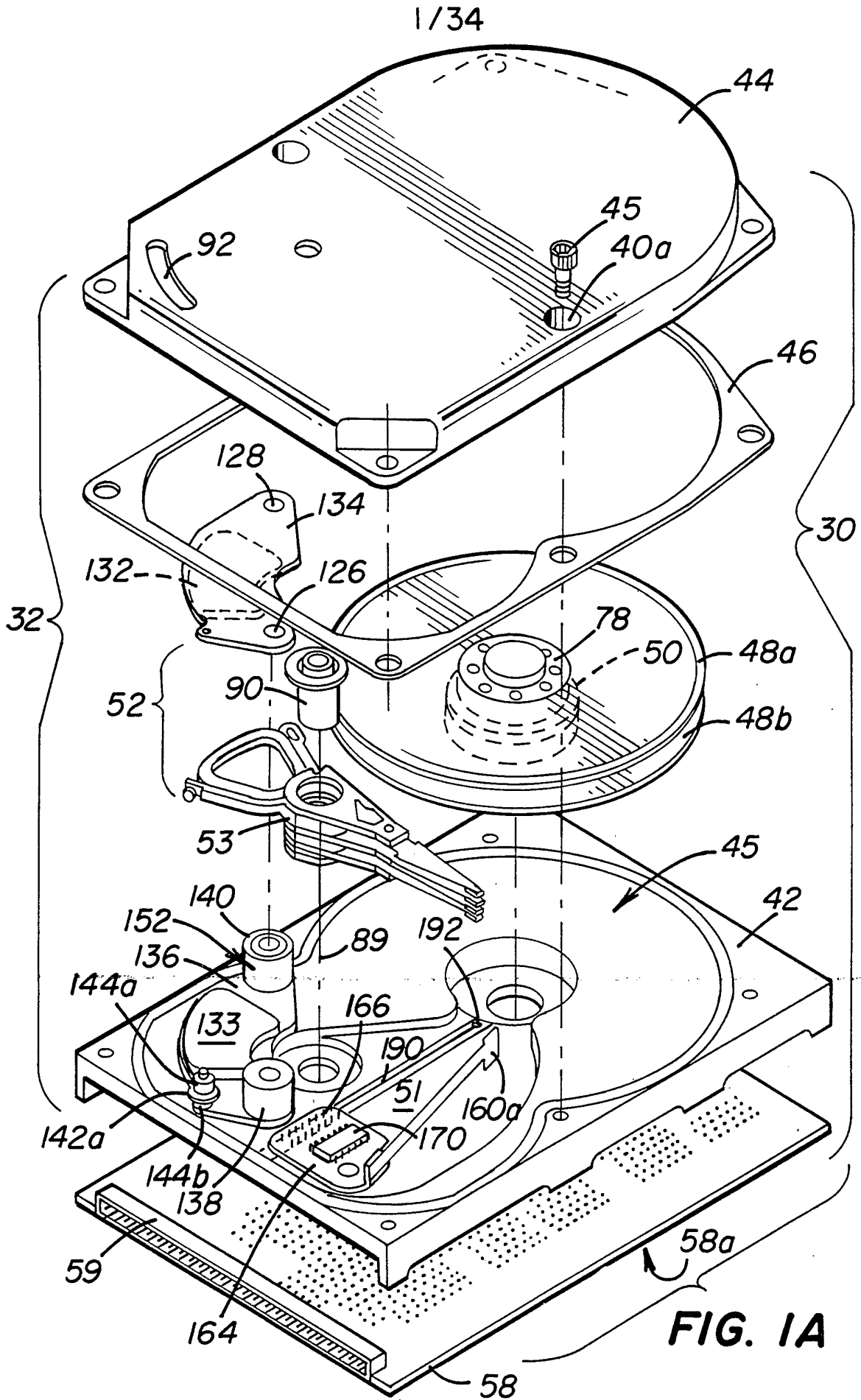

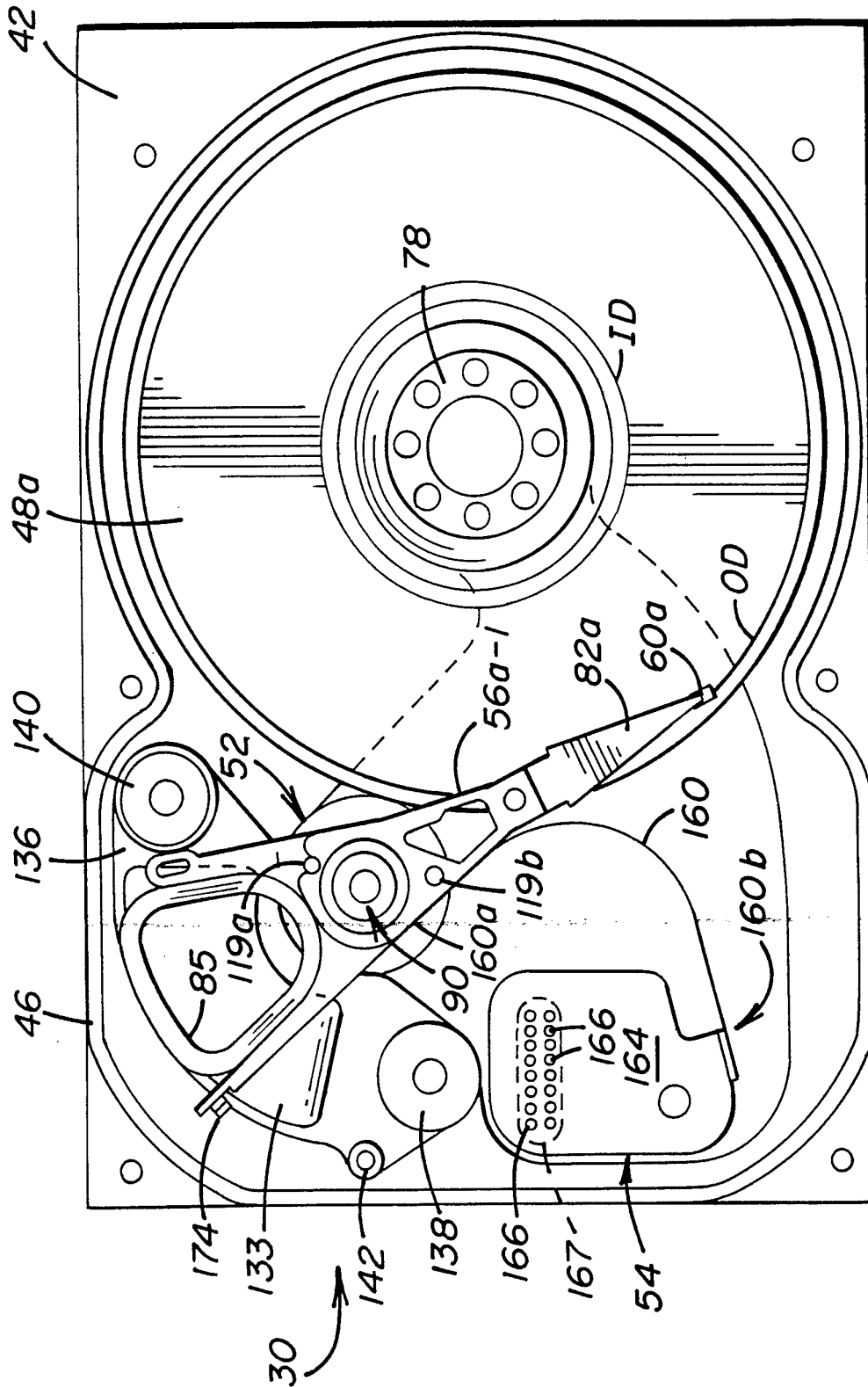

FIG. 1B

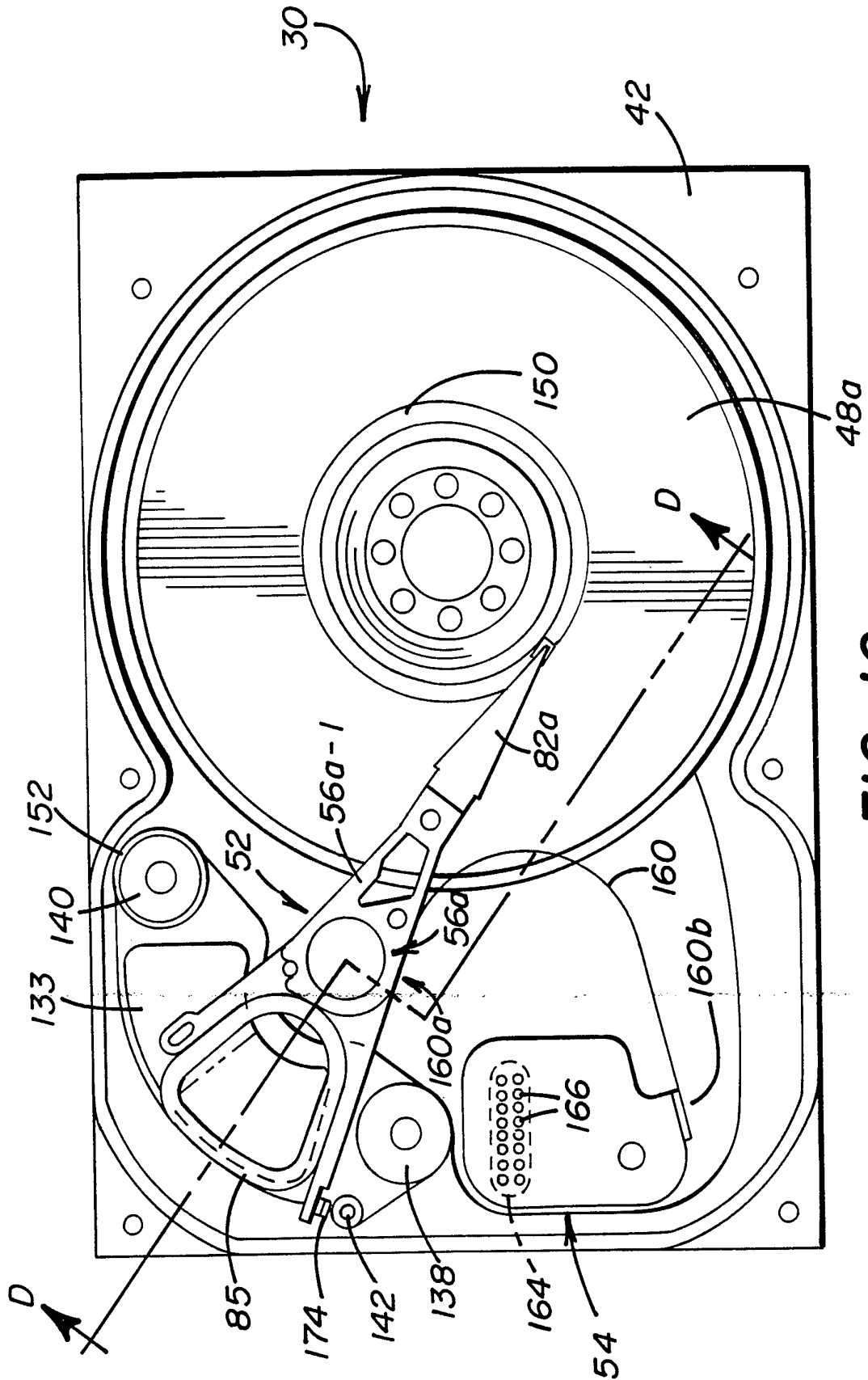

FIG. 1C

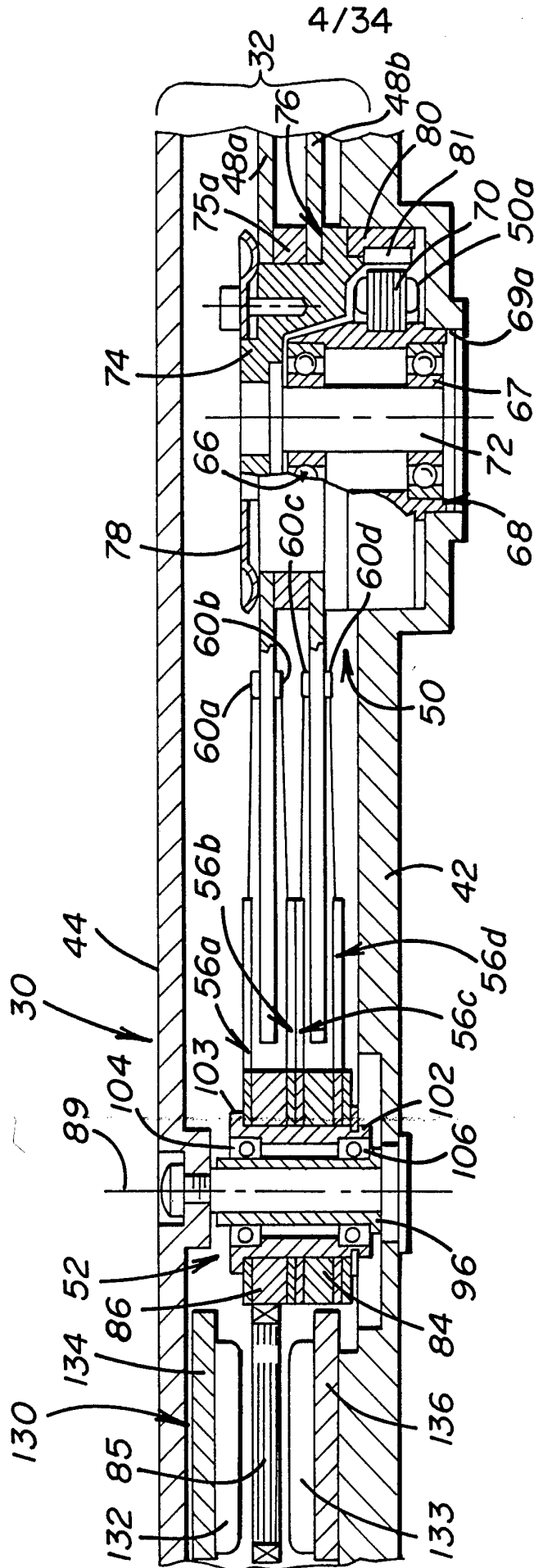

FIG. 1D

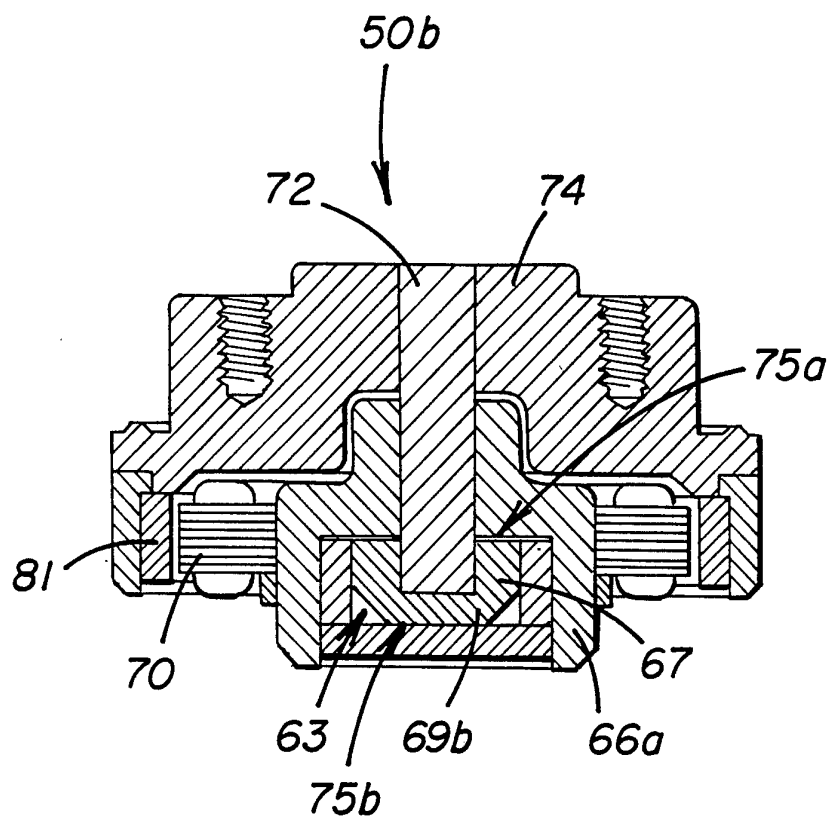

FIG. 1E

7/34

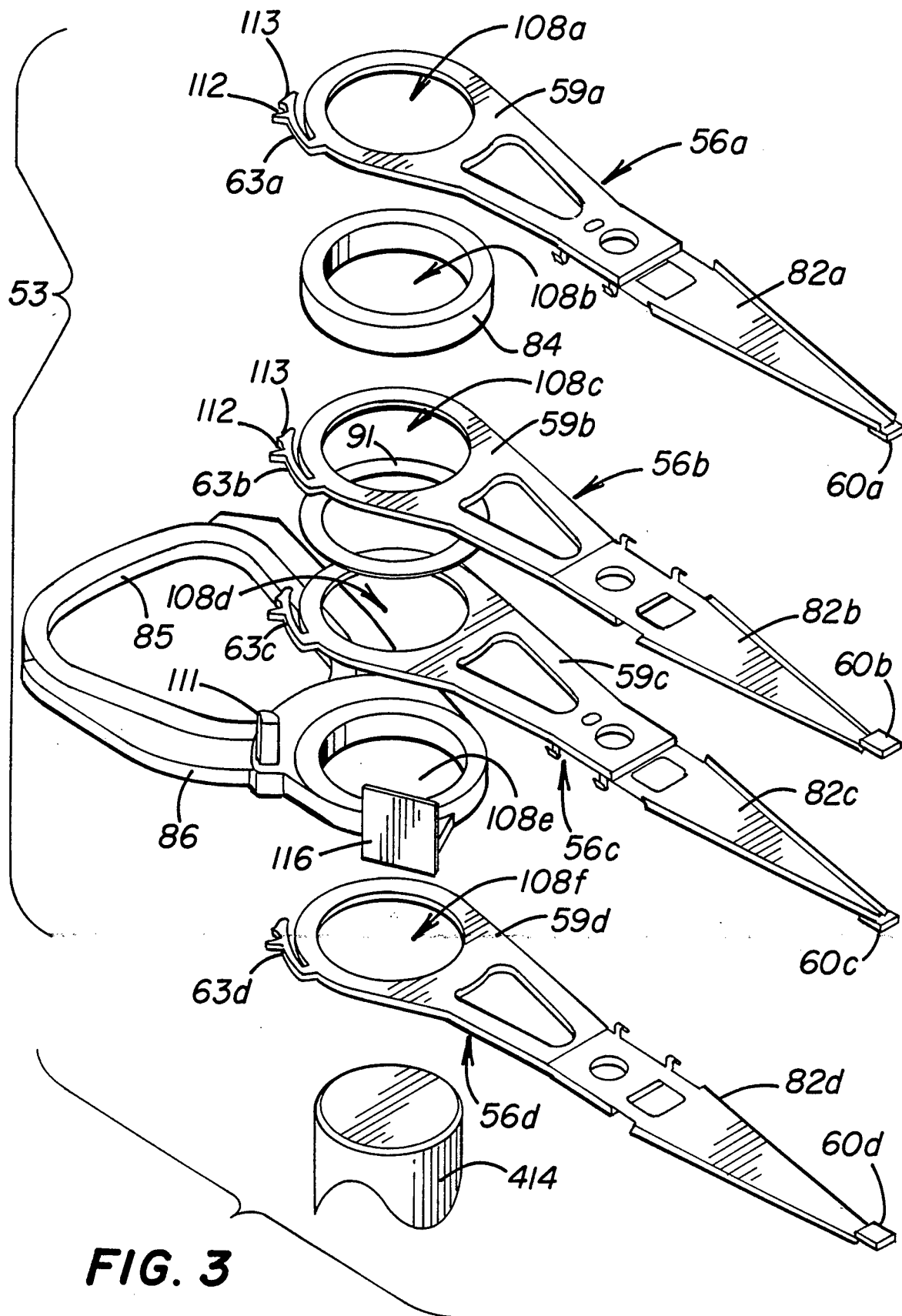

FIG. 3

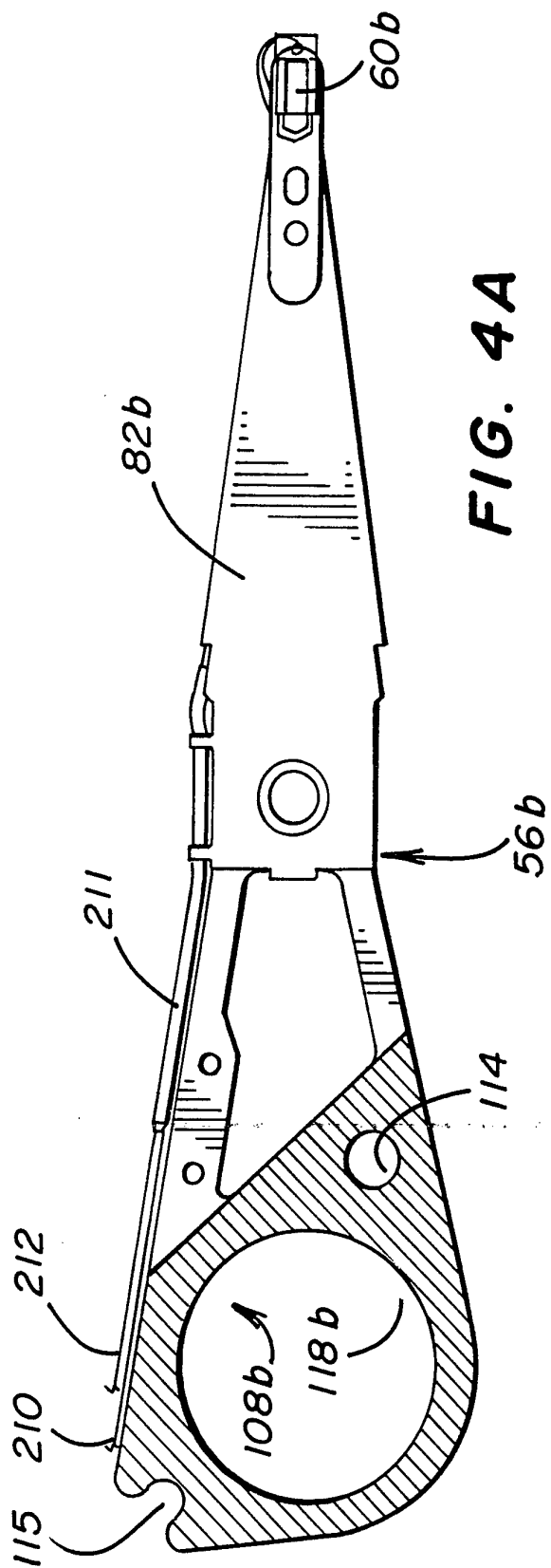

FIG. 4A

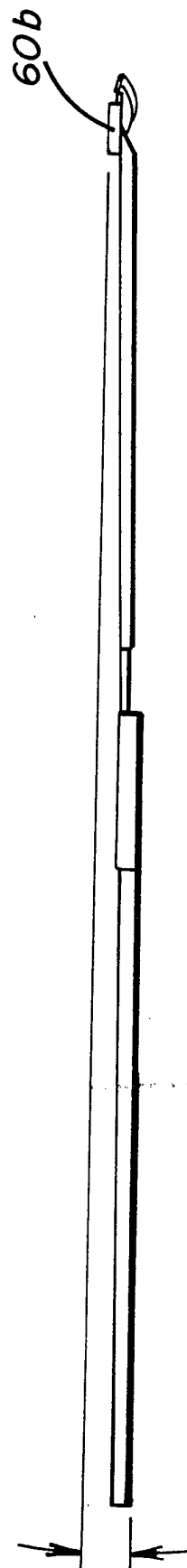

FIG. 4B

9/34

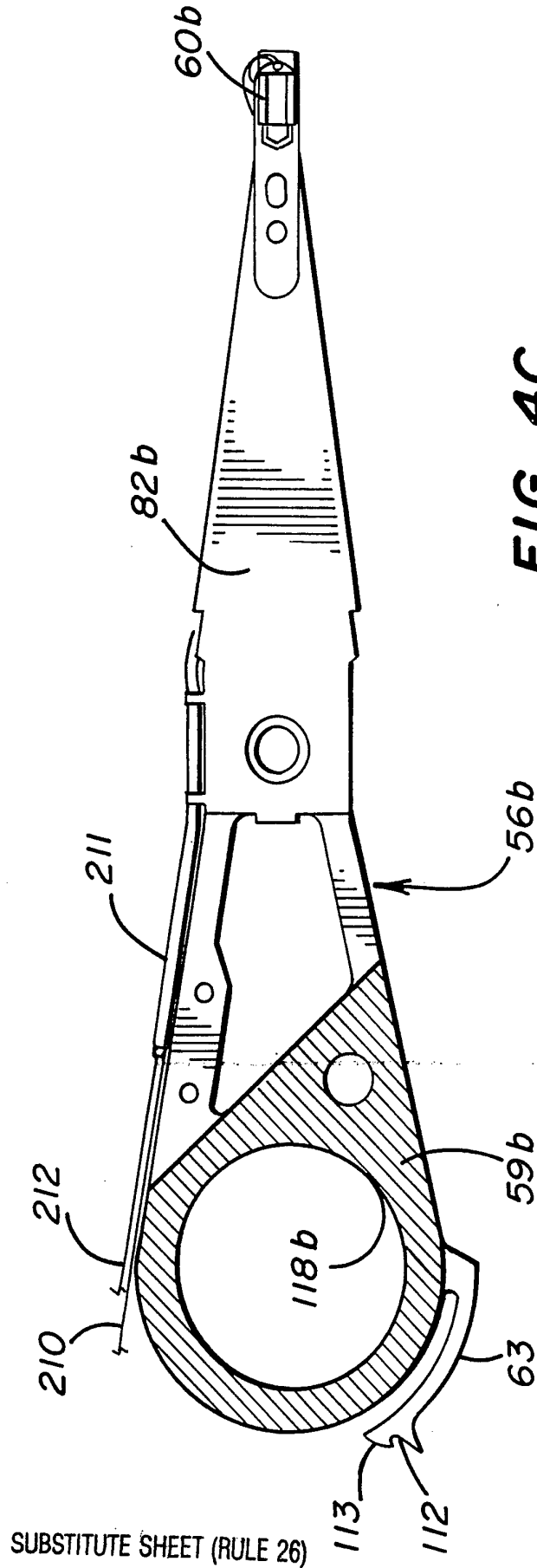
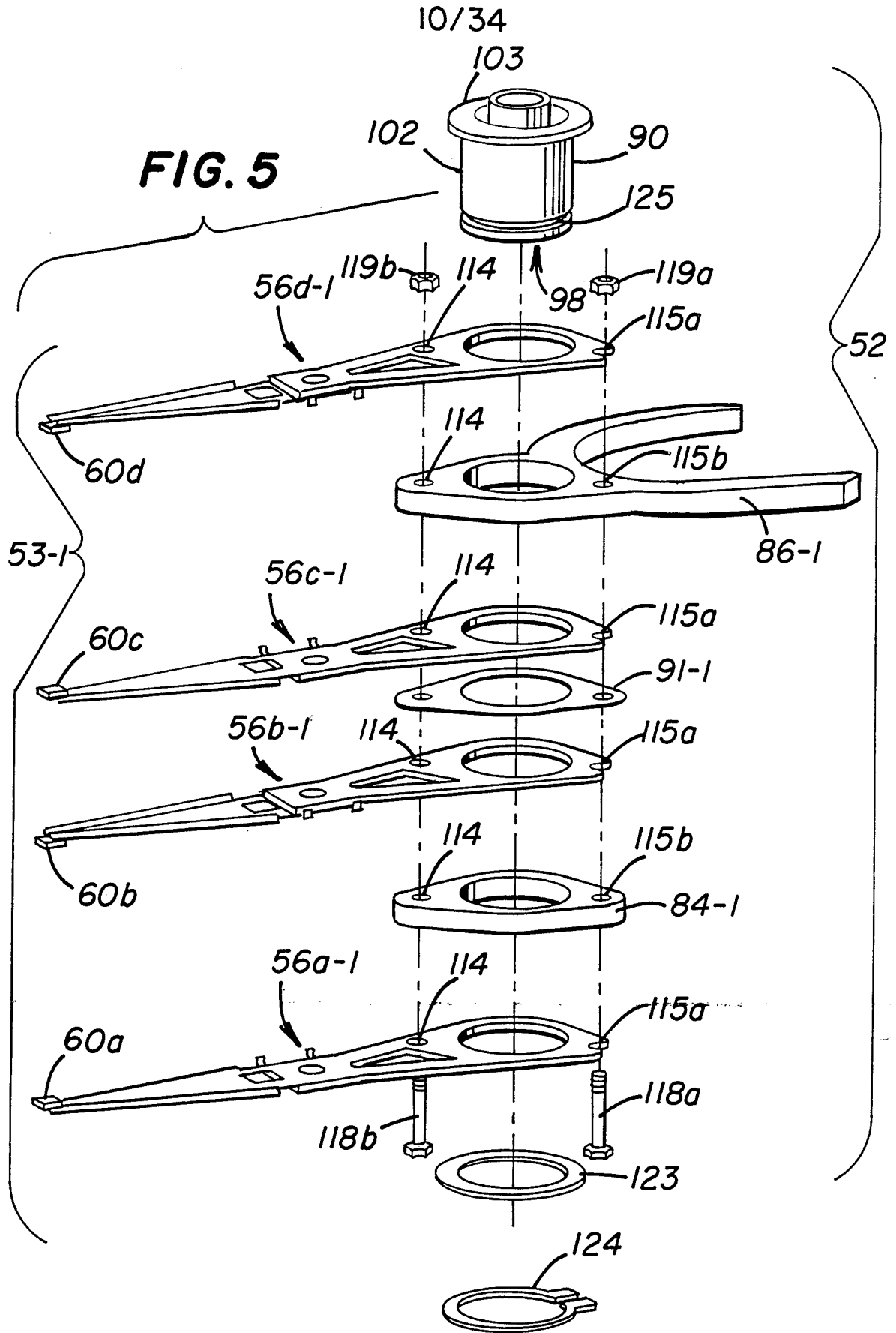

FIG. 4C



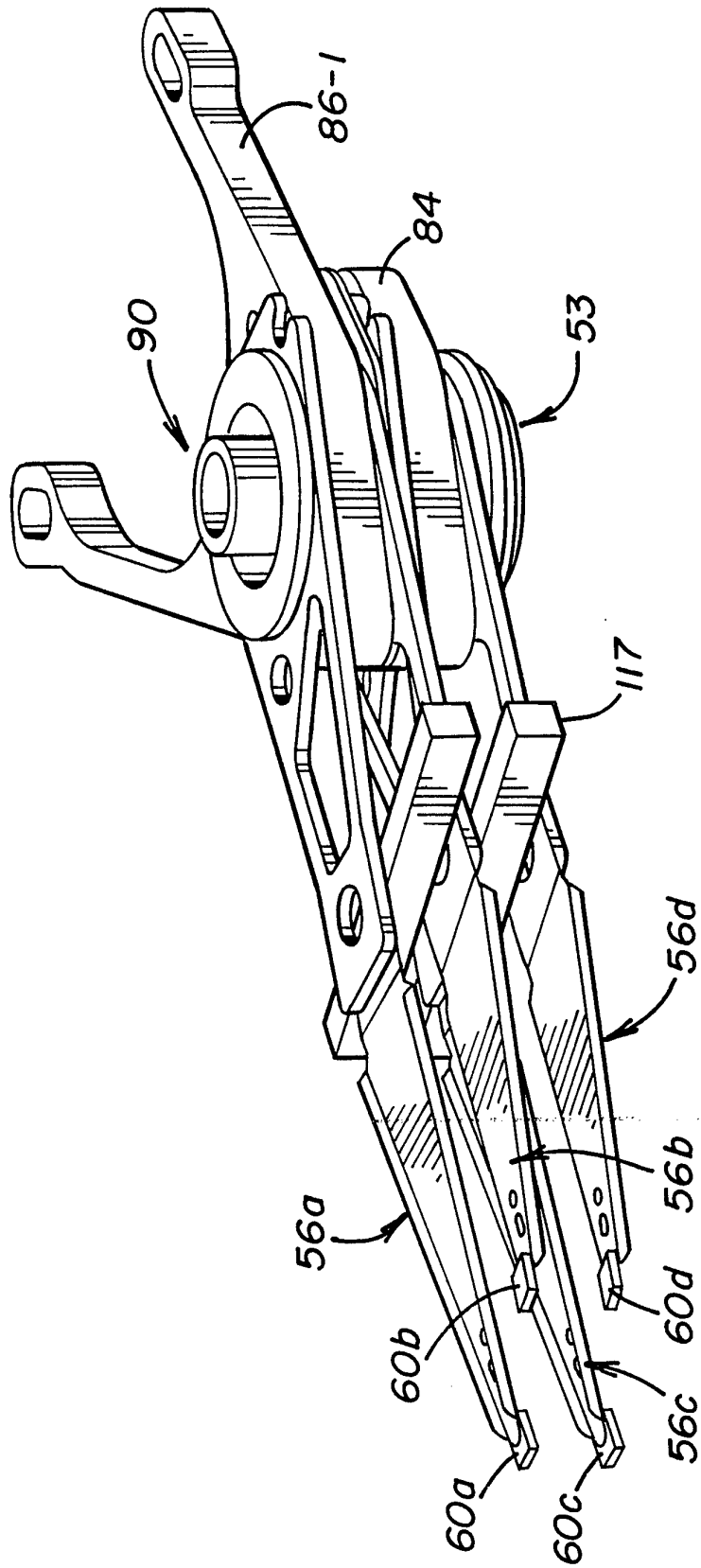
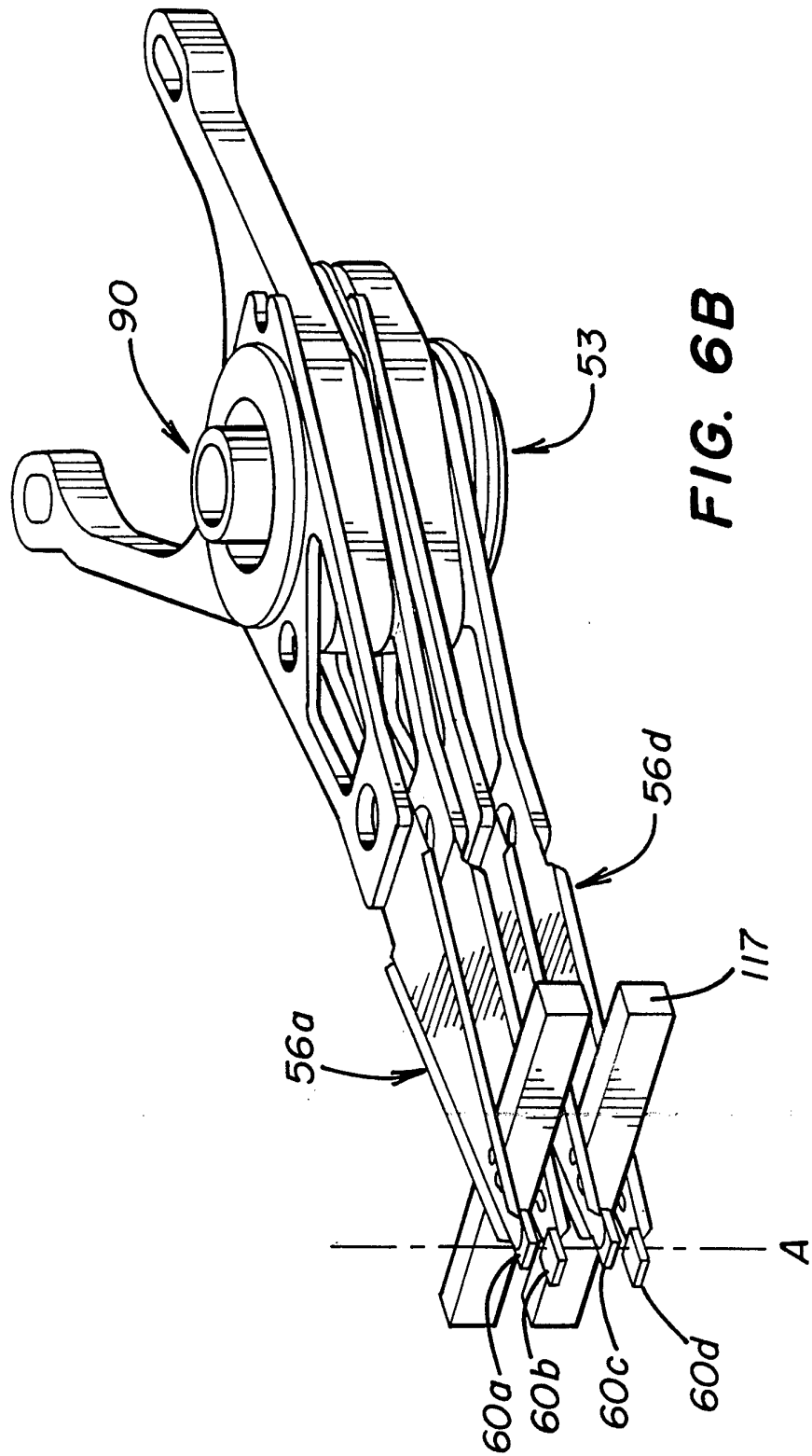
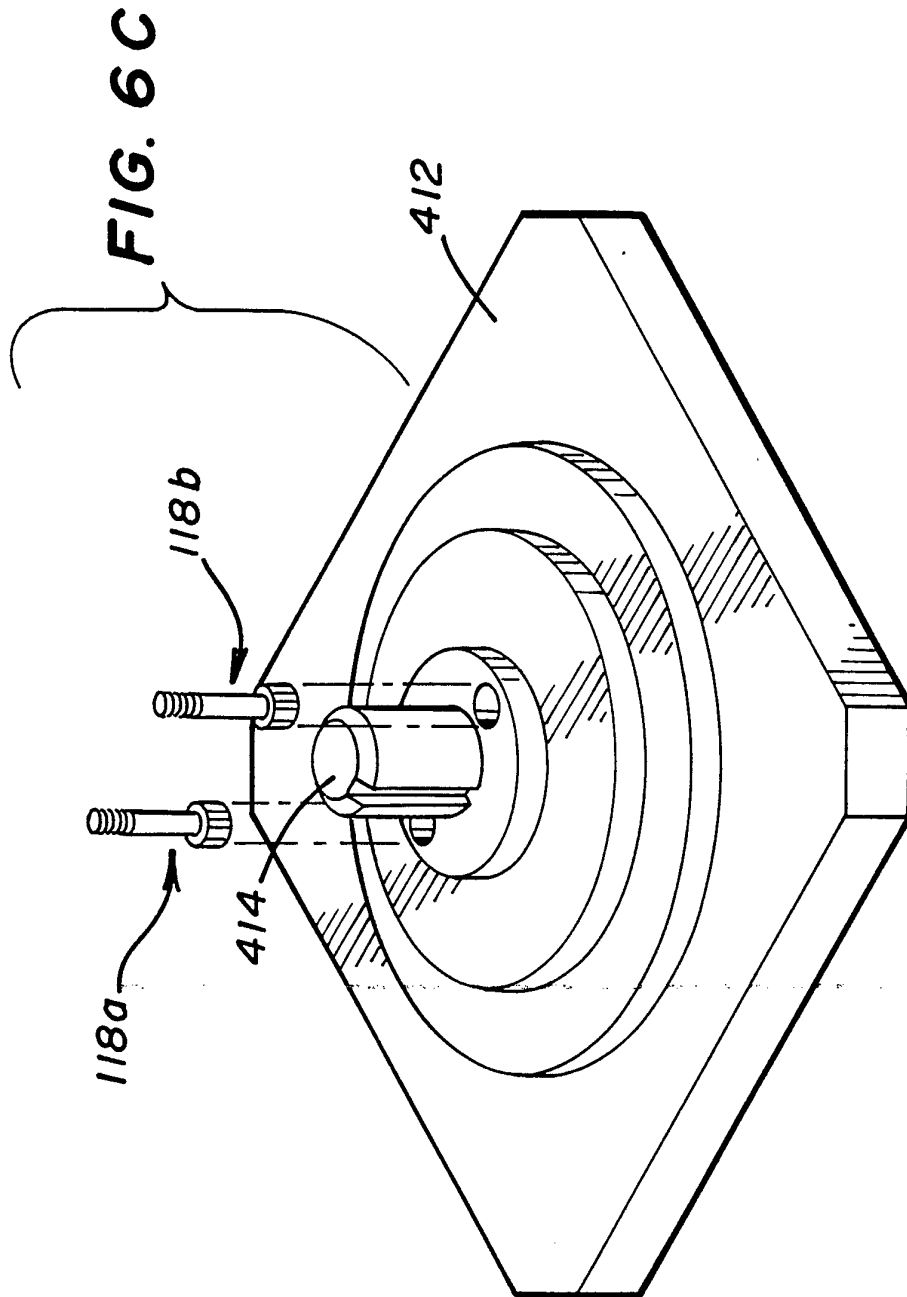

FIG. 6A





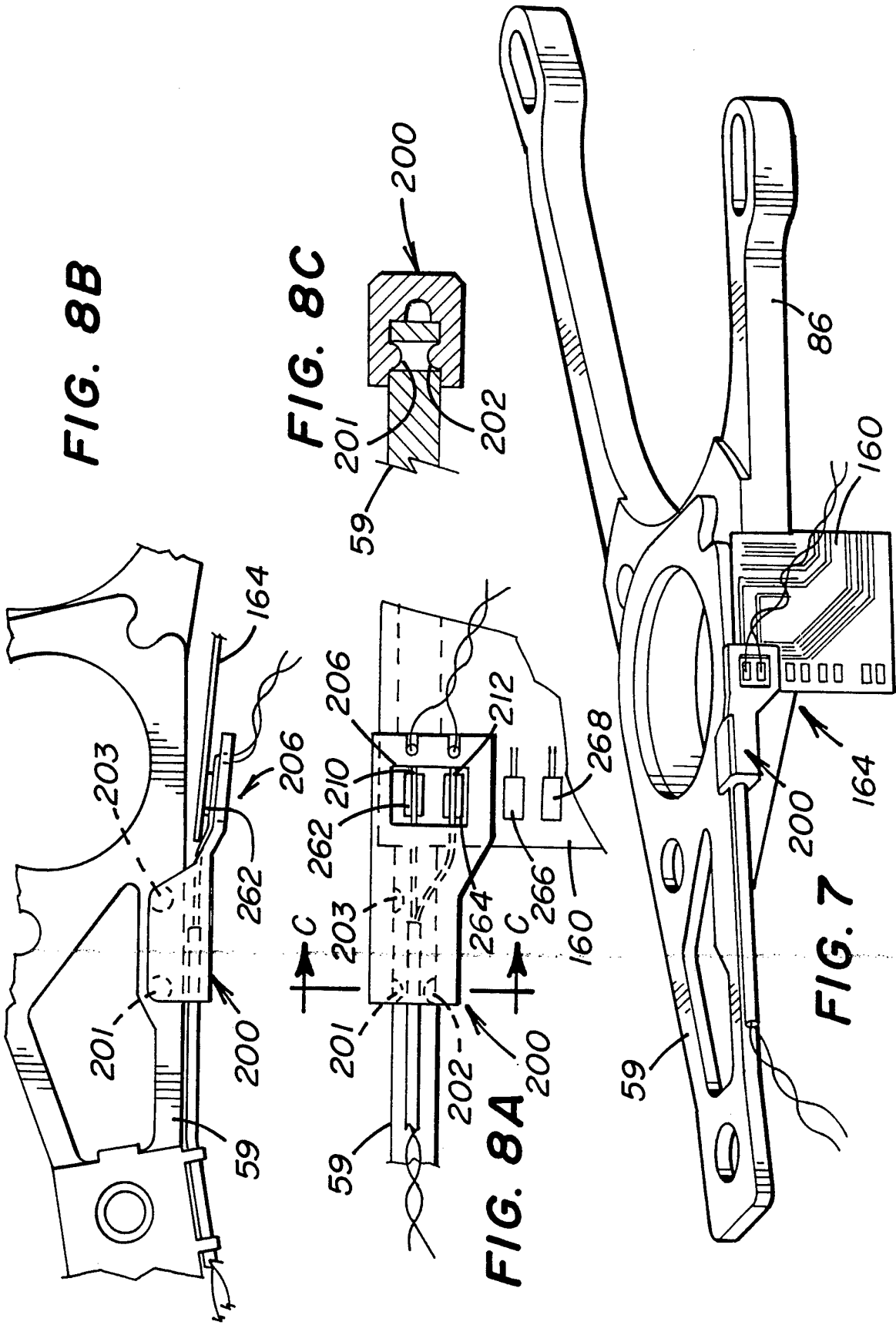

FIG. 8B

FIG. 8C

FIG. 8A

FIG. 7

FIG. 9

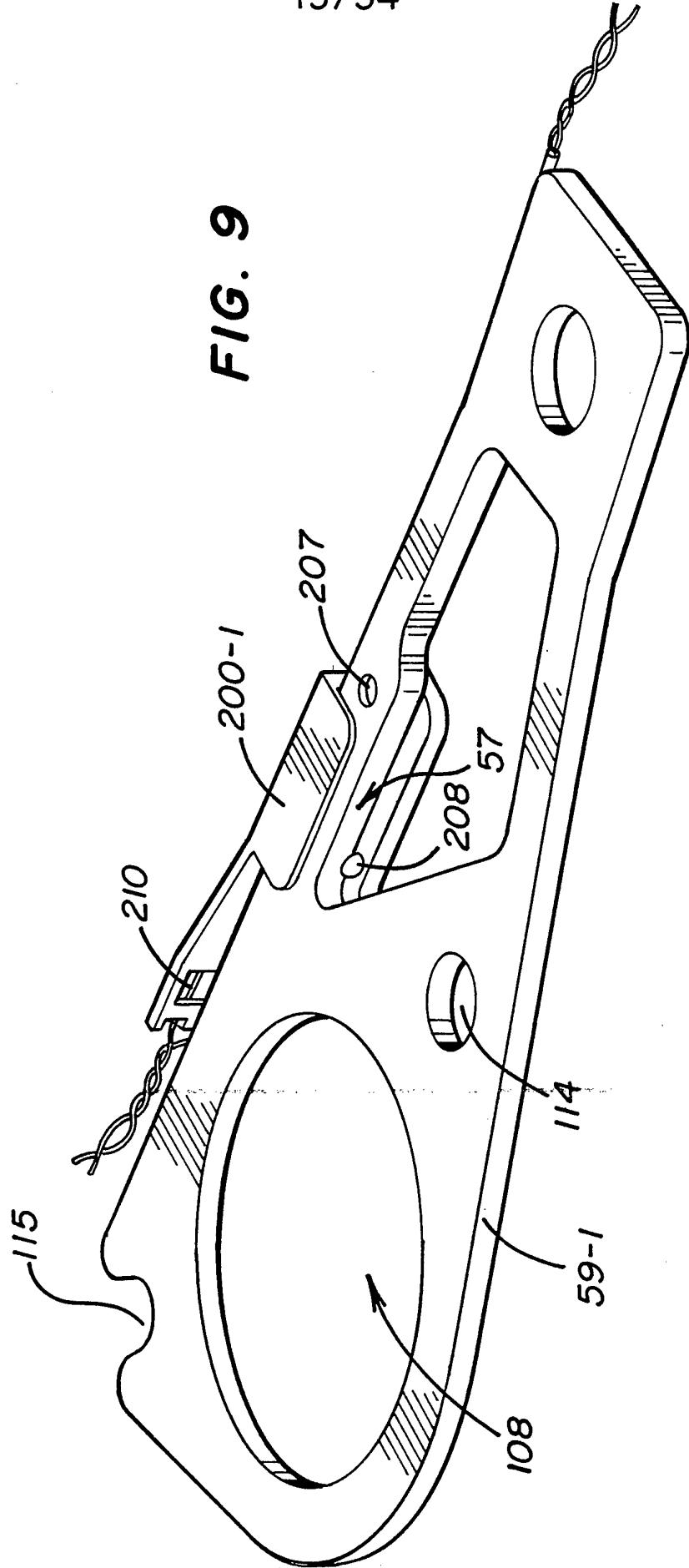

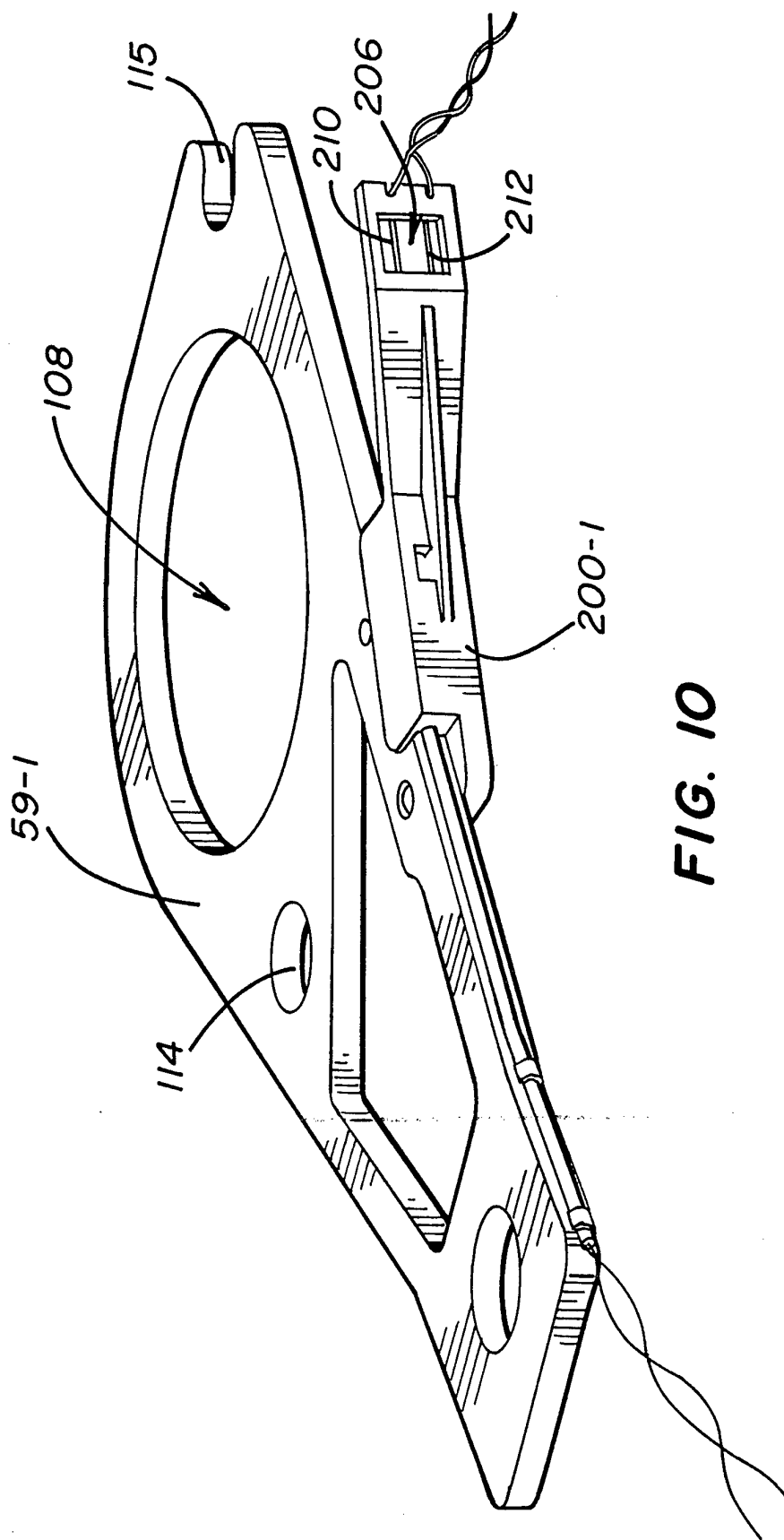

FIG. 10

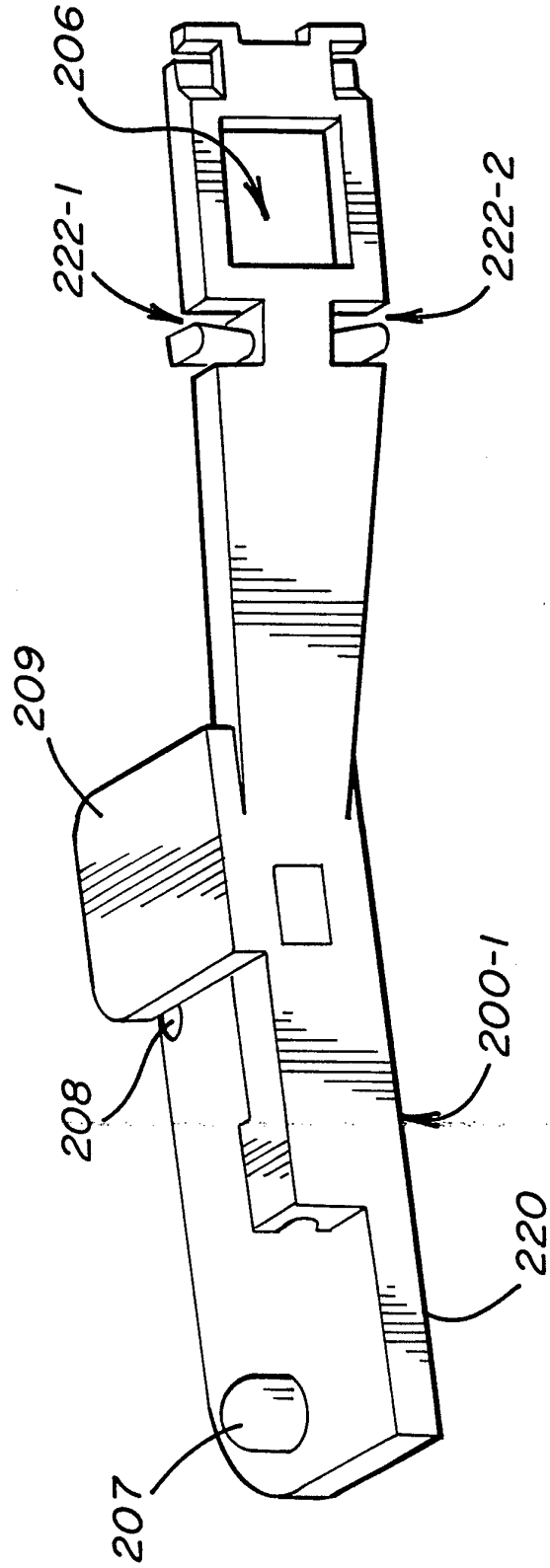

FIG. 11

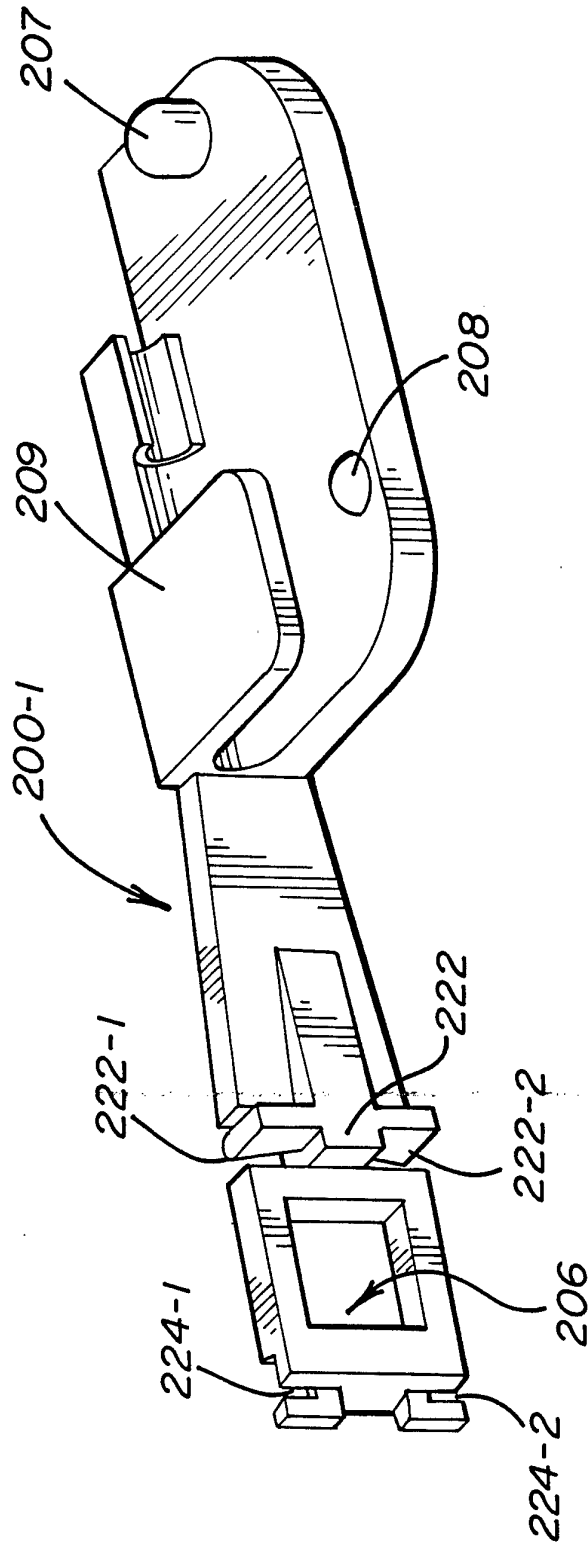

FIG. 12

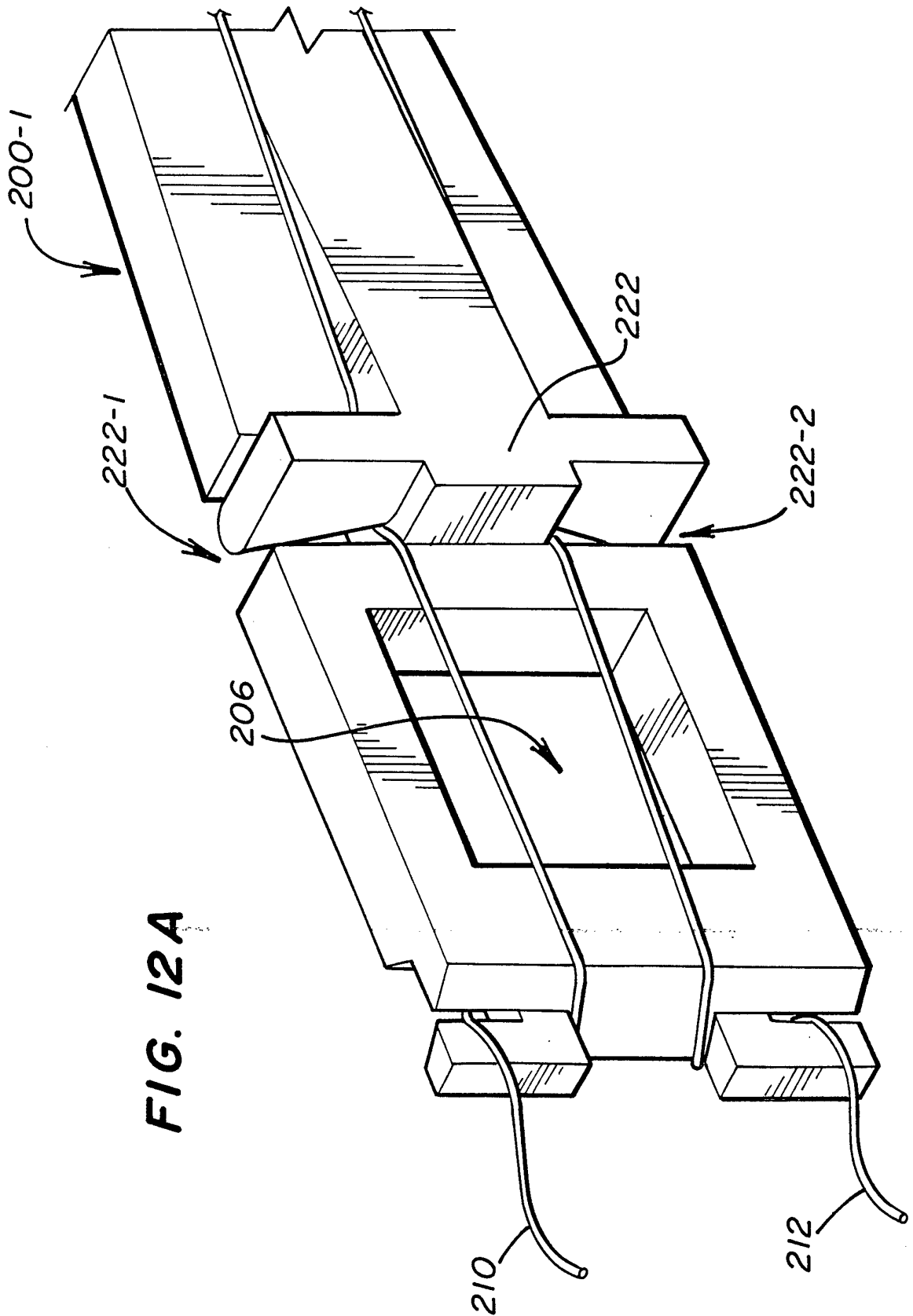

FIG. 12A

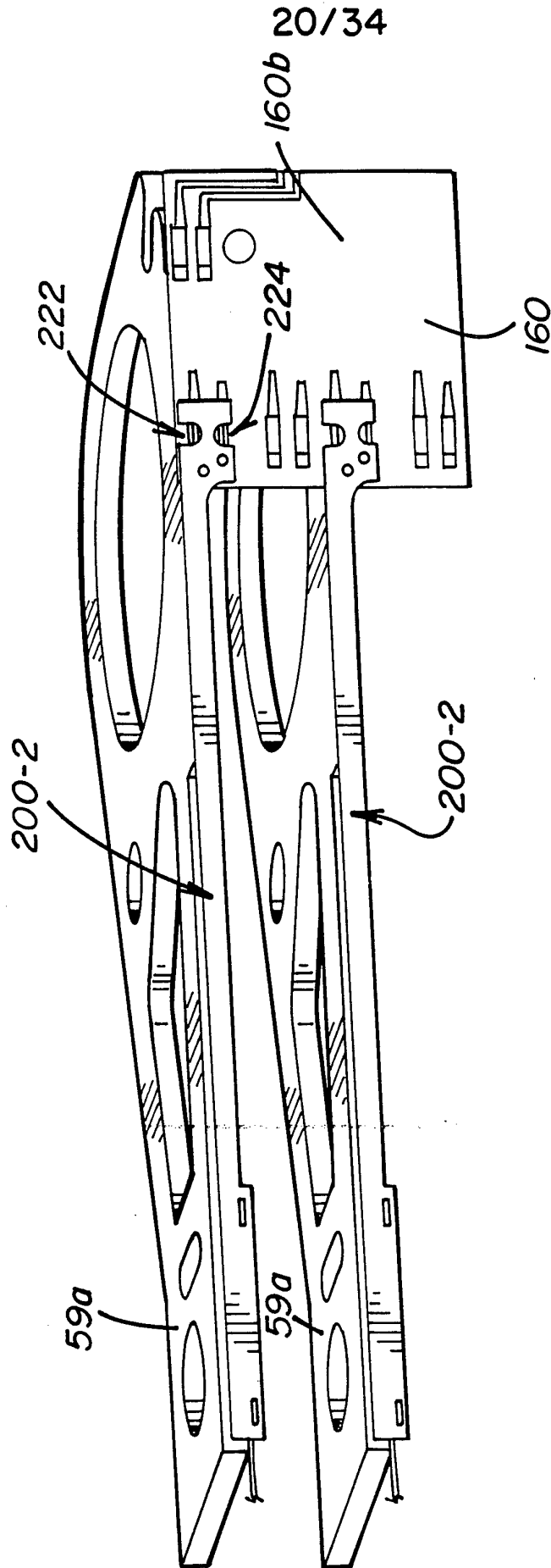

FIG. 13

21/34

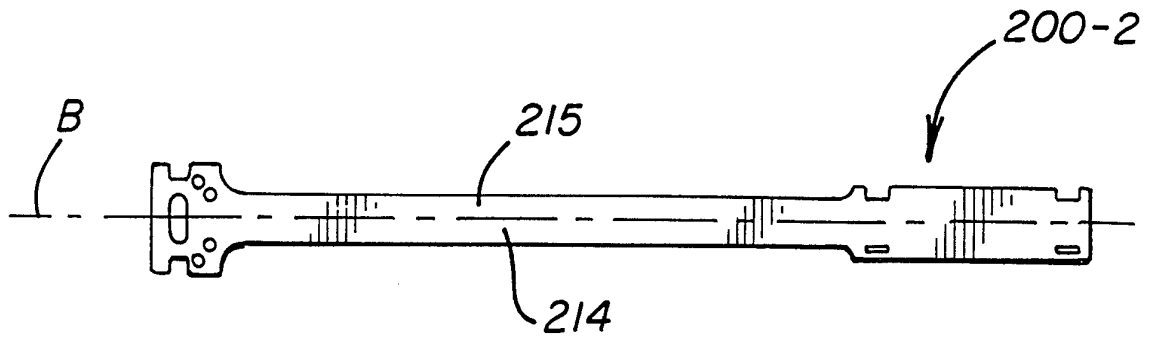

FIG. 14

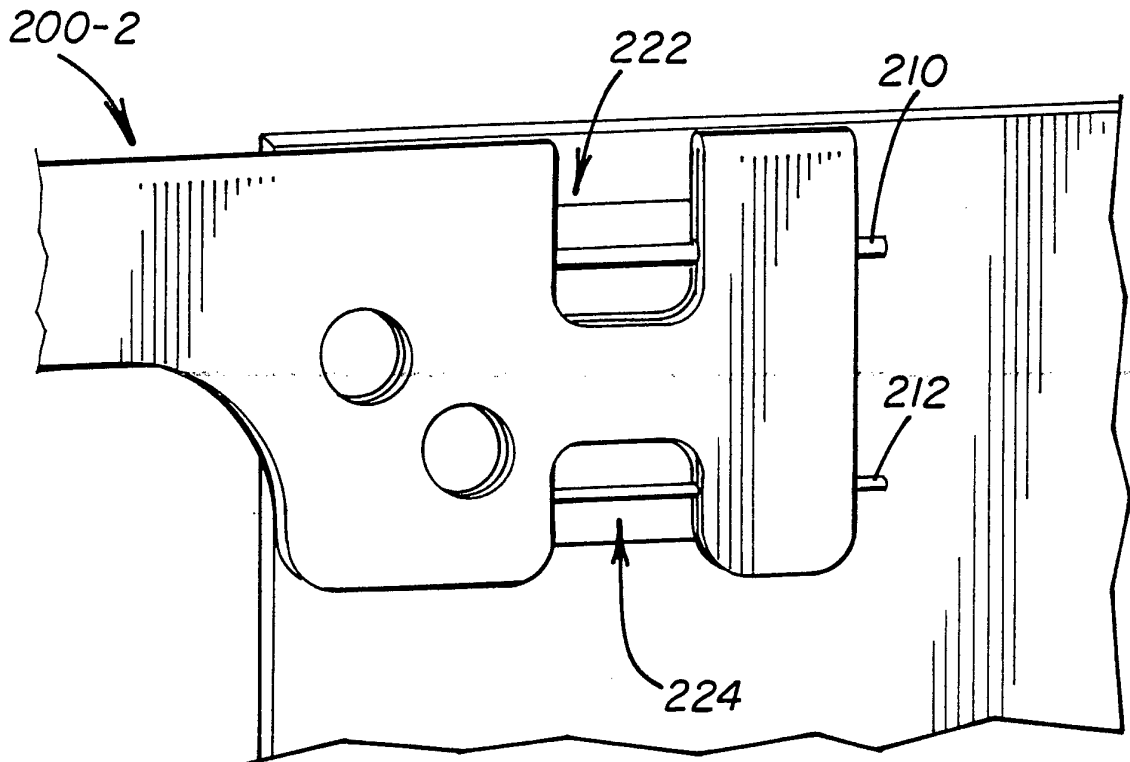

FIG. 15

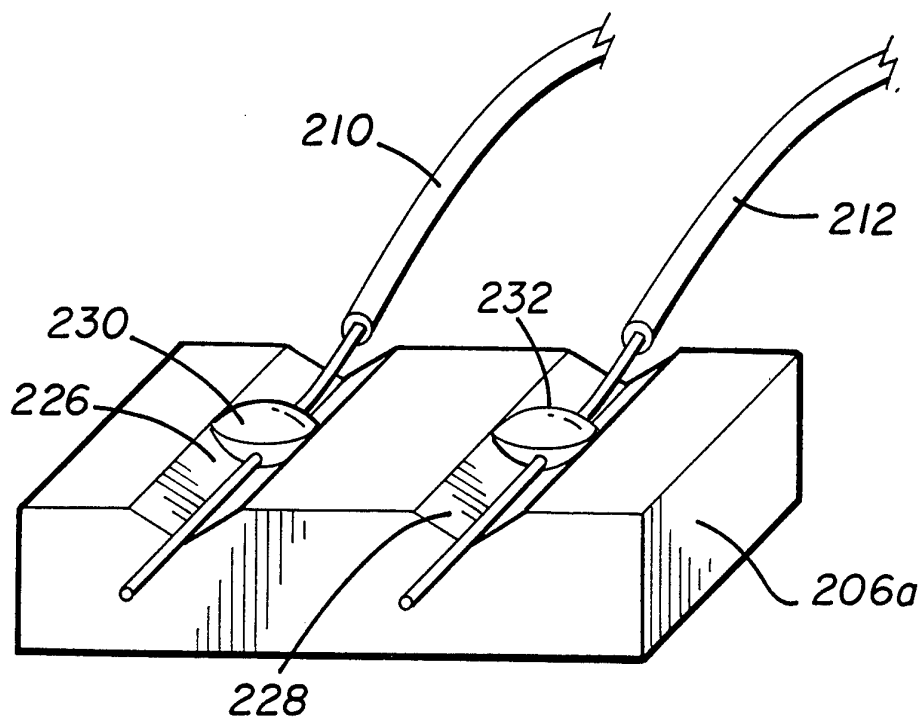

FIG. 16A

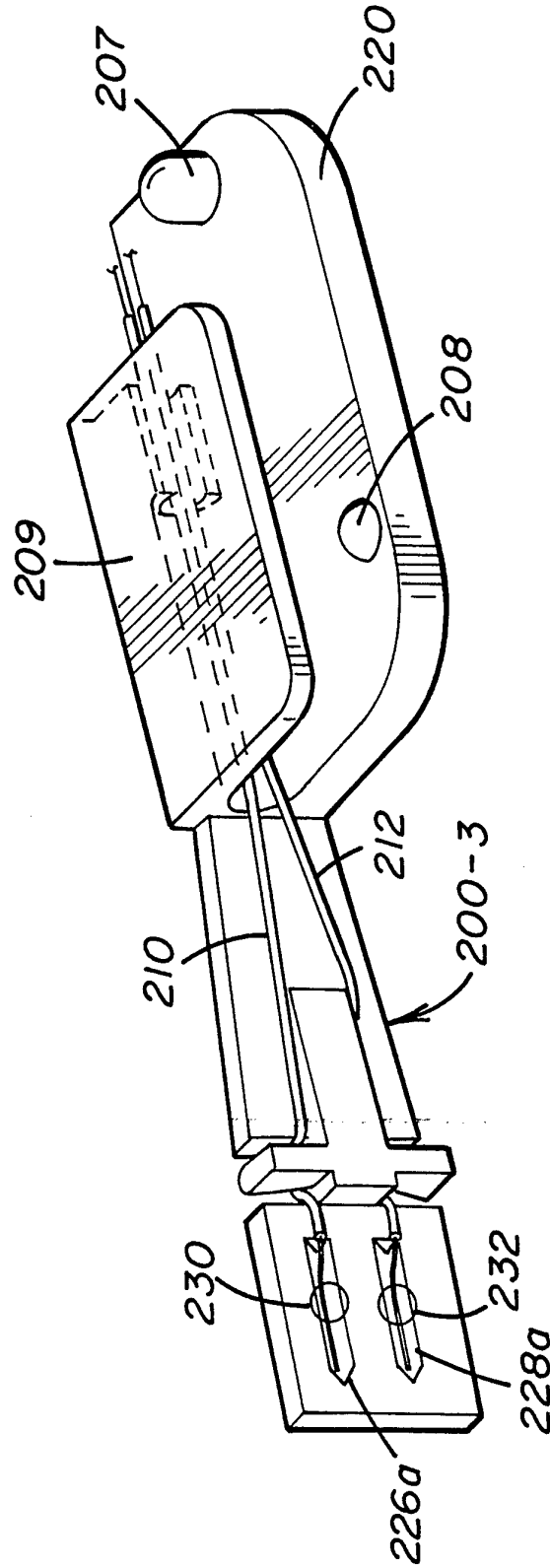

FIG. 16B

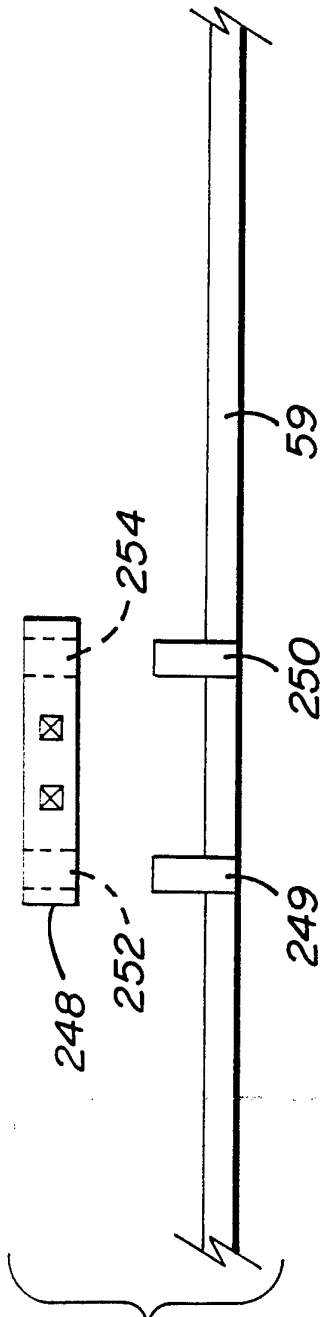

FIG. 17B

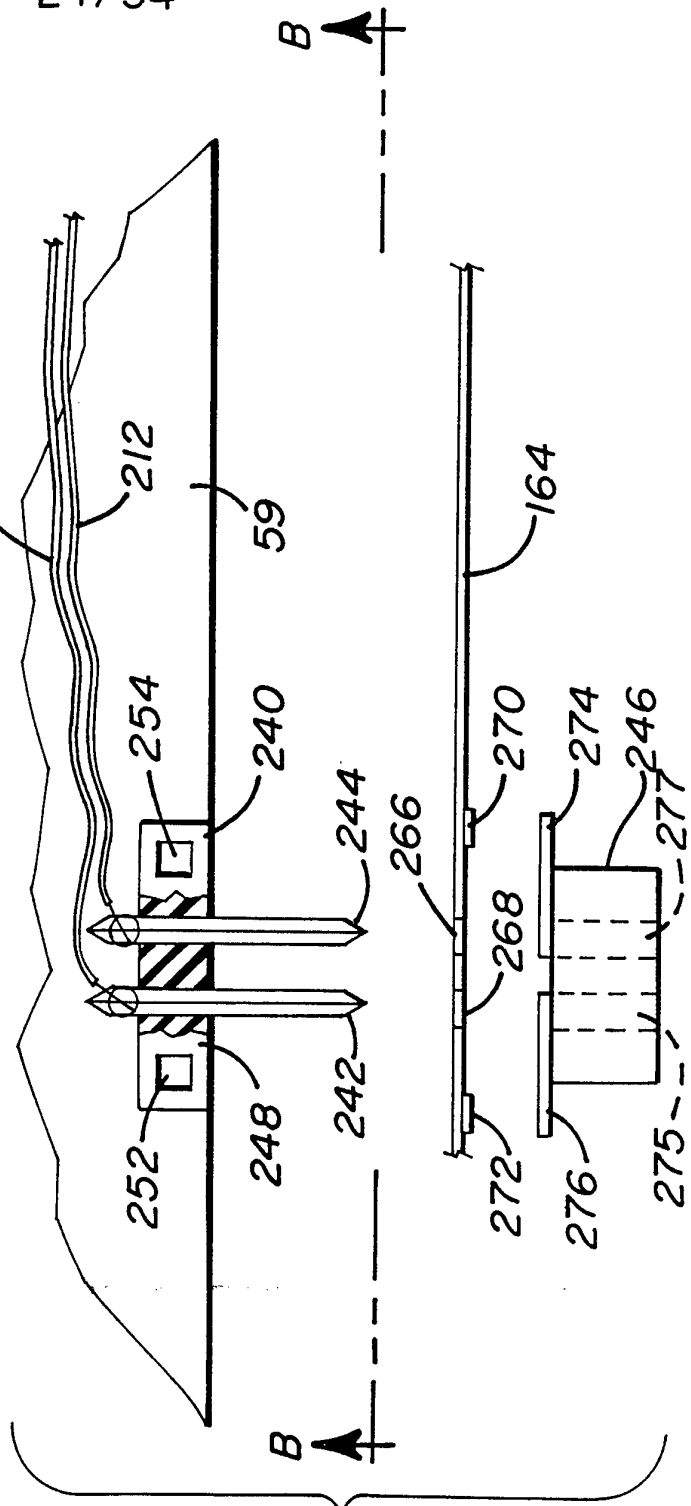

FIG. 17A

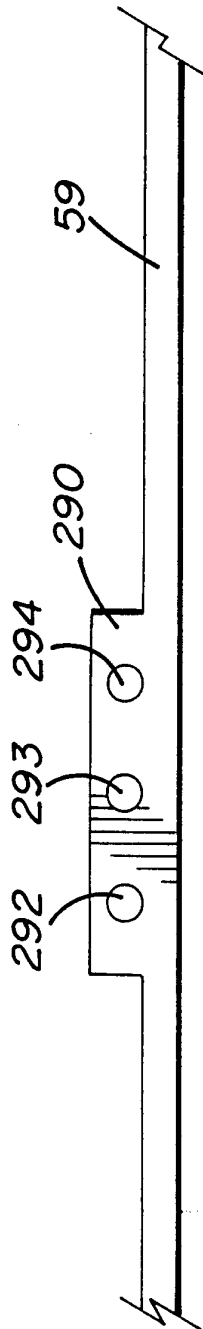

FIG. 18B

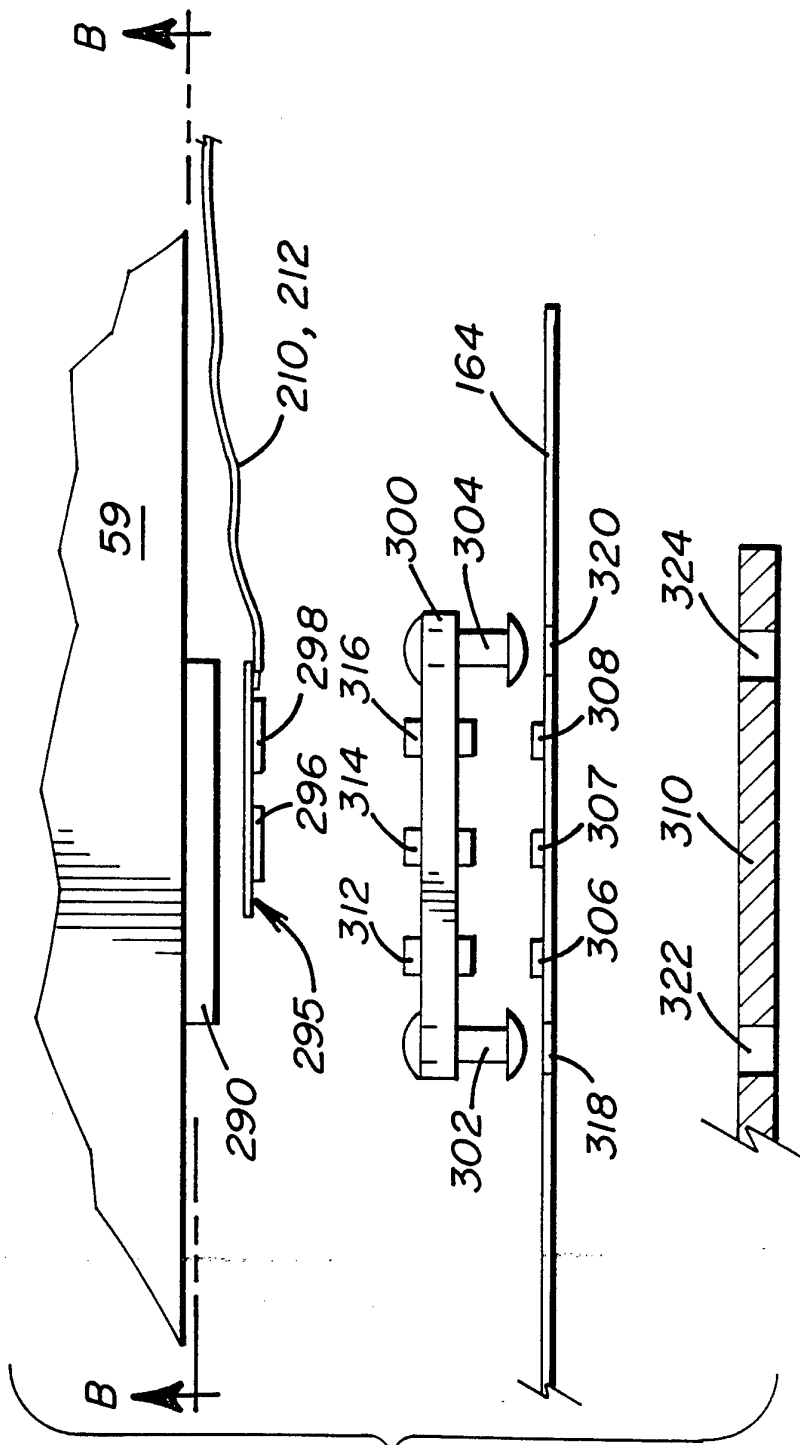
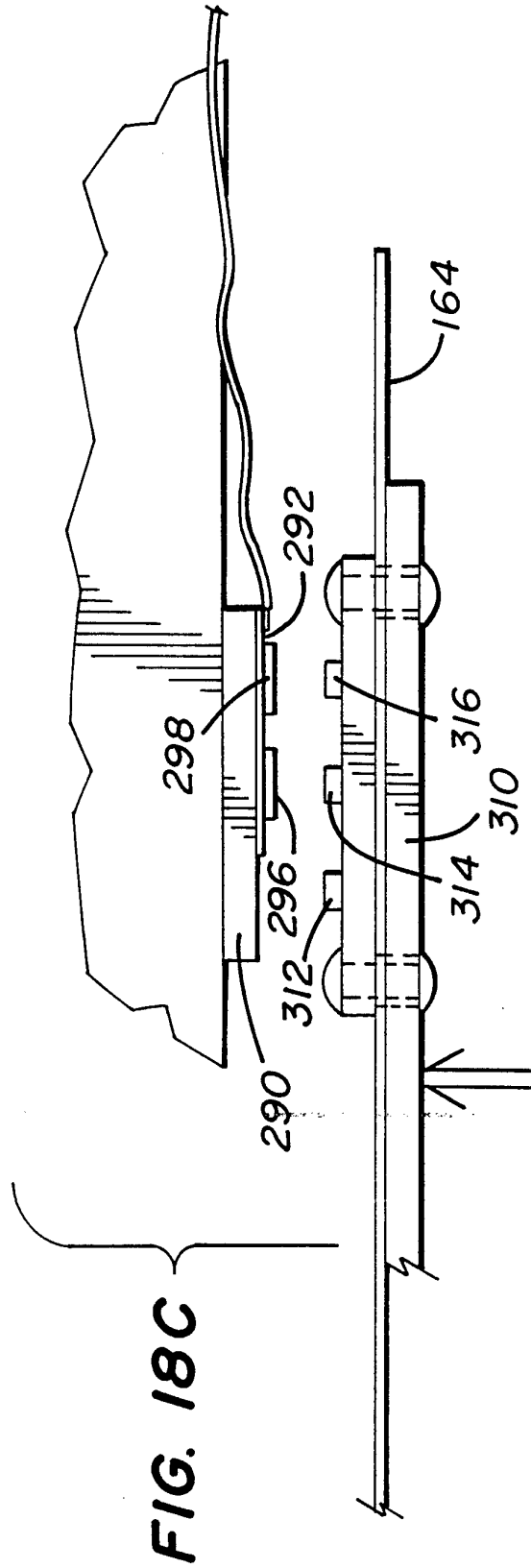

FIG. 18A



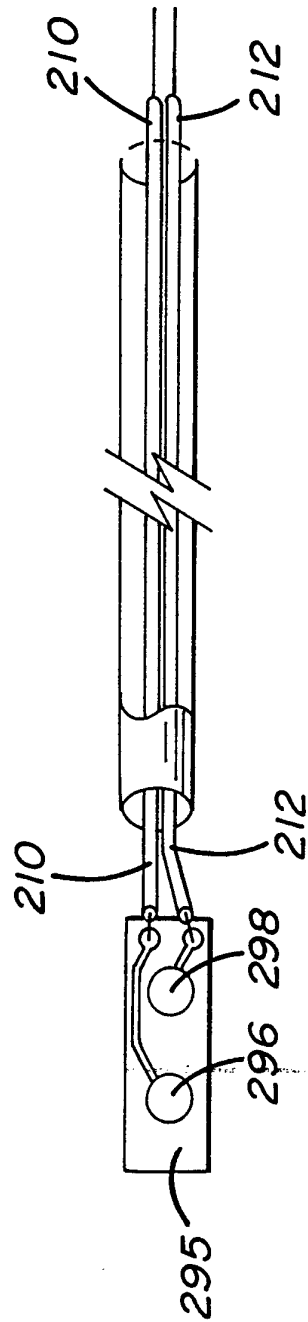

FIG. 18D

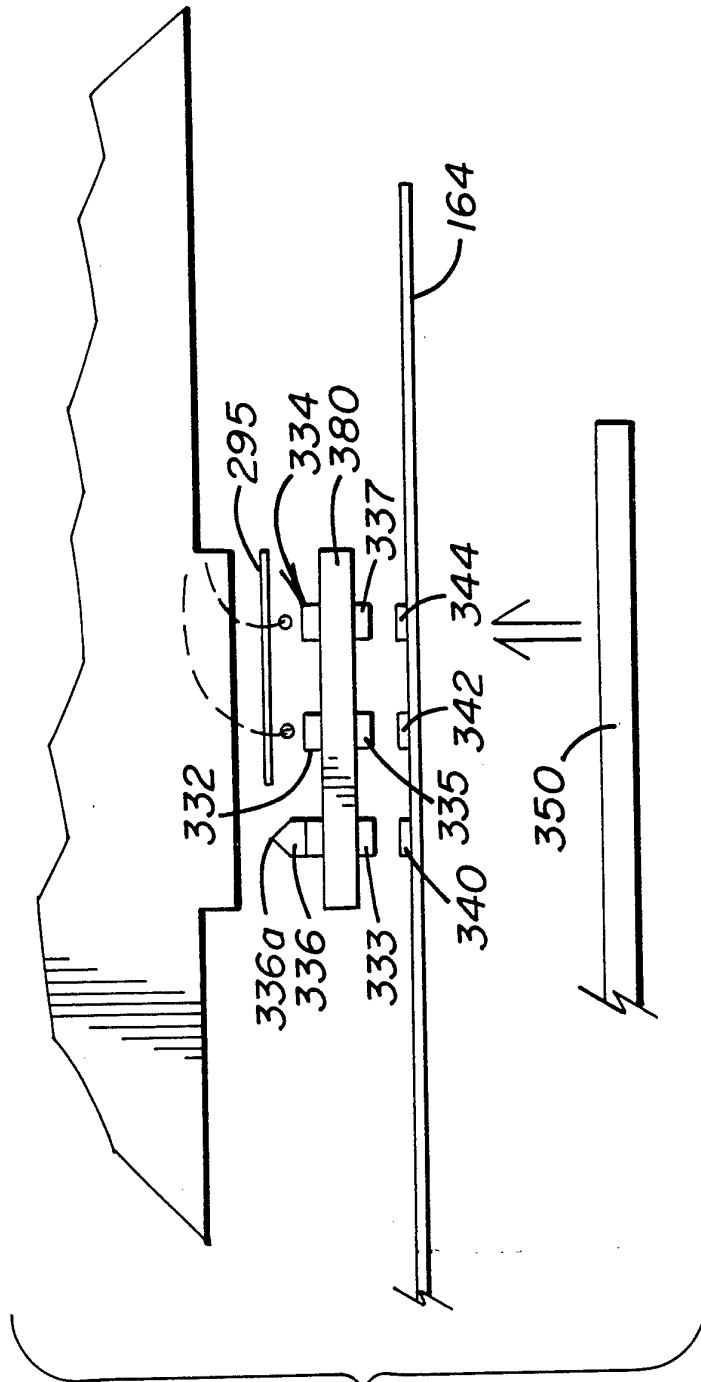

FIG. 19

30/34

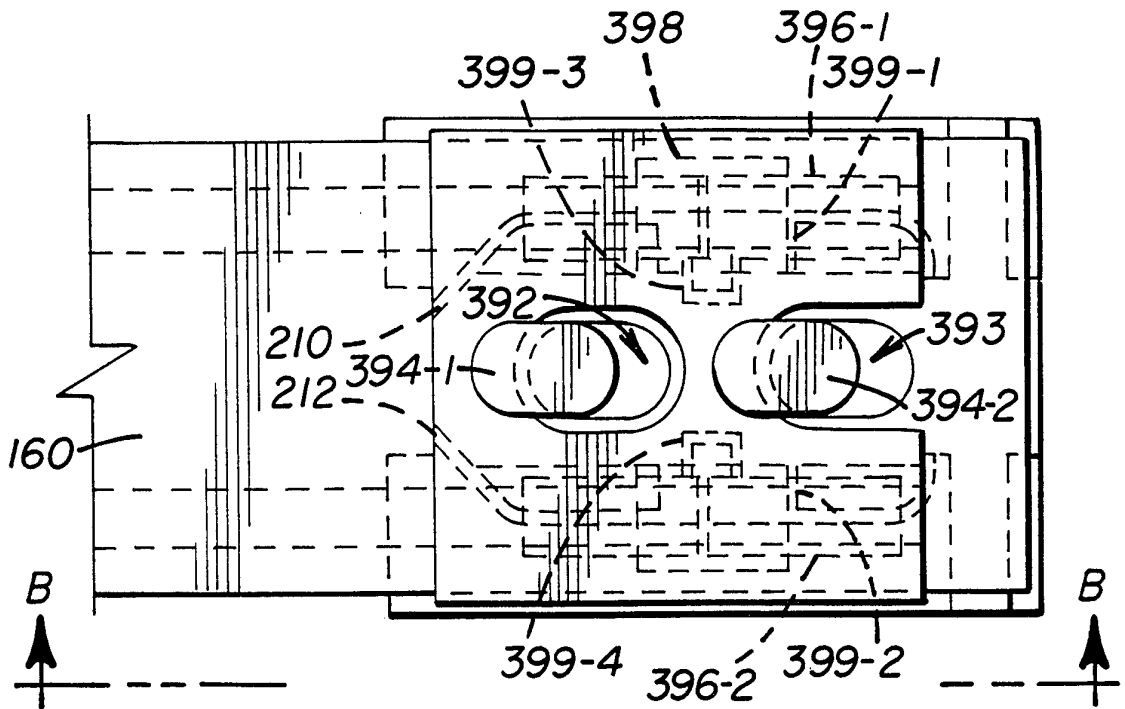

FIG. 21A

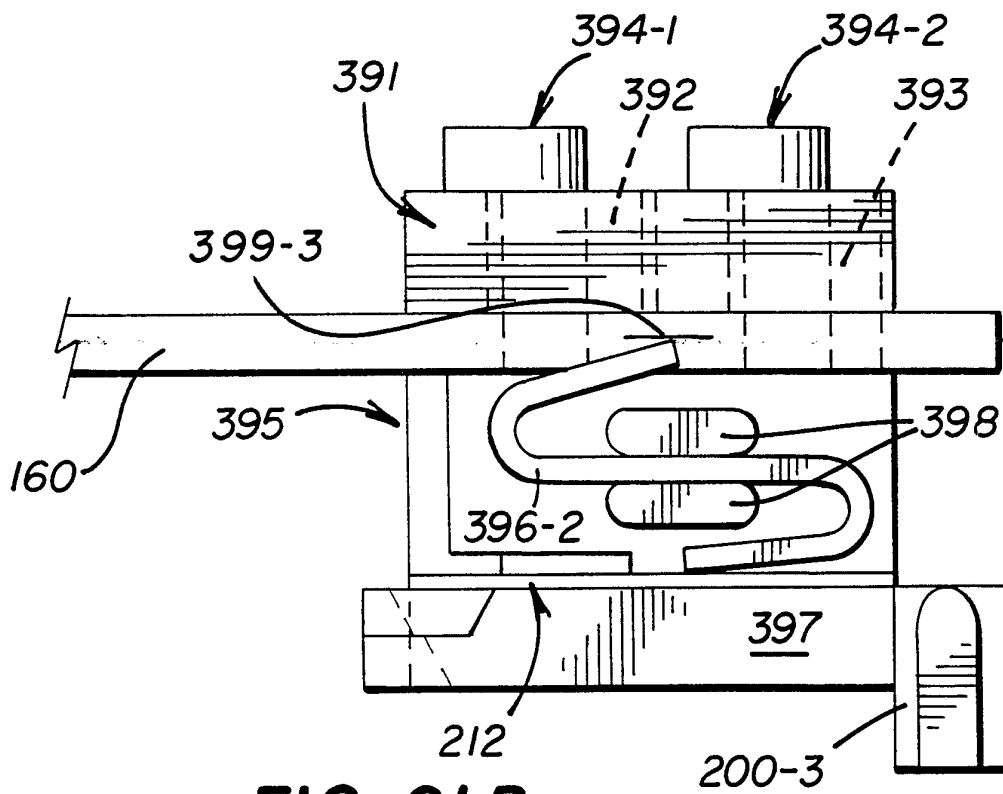

FIG. 21B

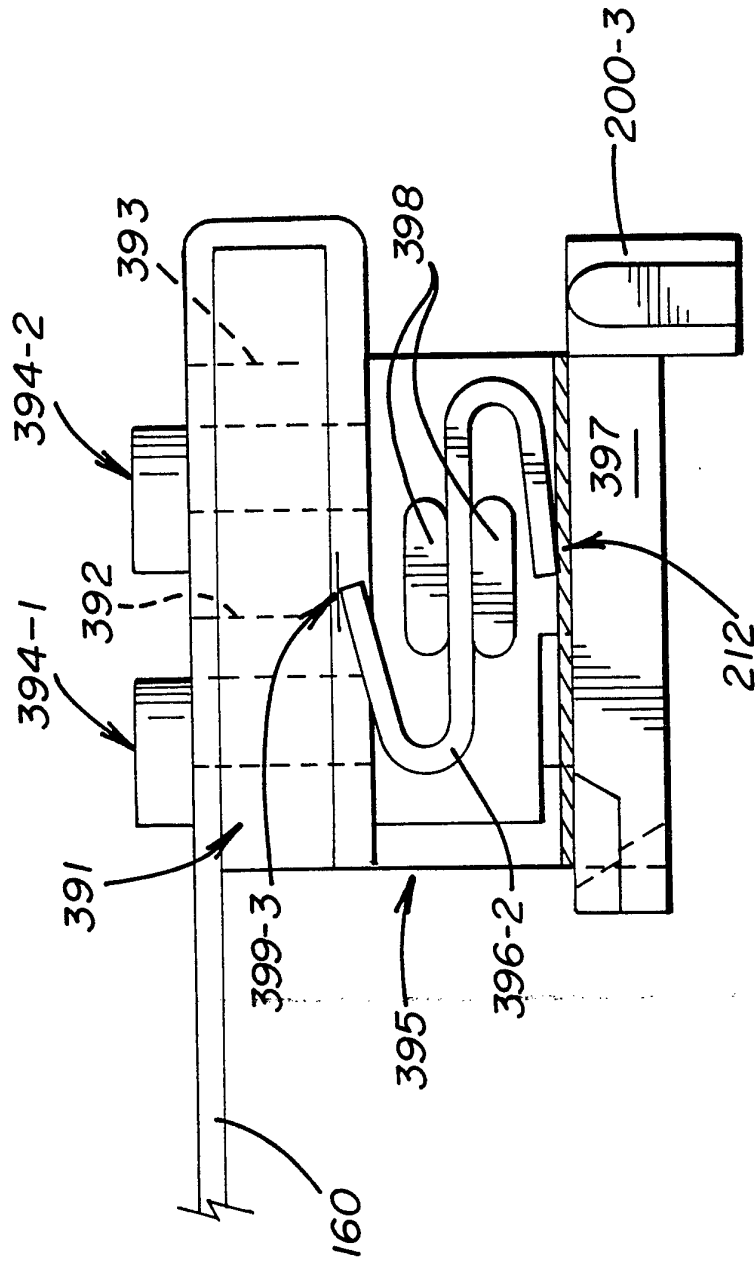
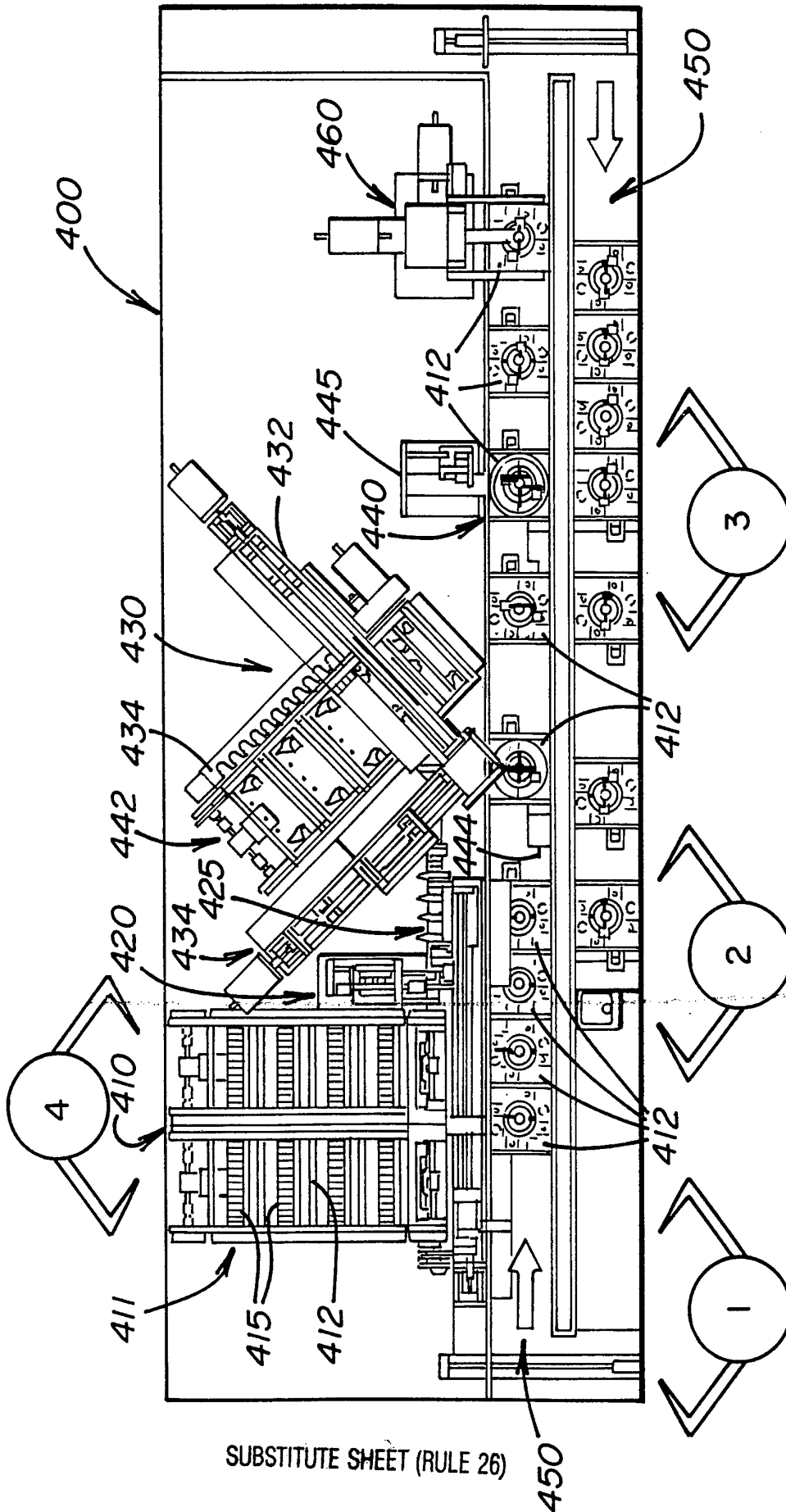

FIG. 21C



SUBSTITUTE SHEET (RULE 26)

FIG. 22

33/34

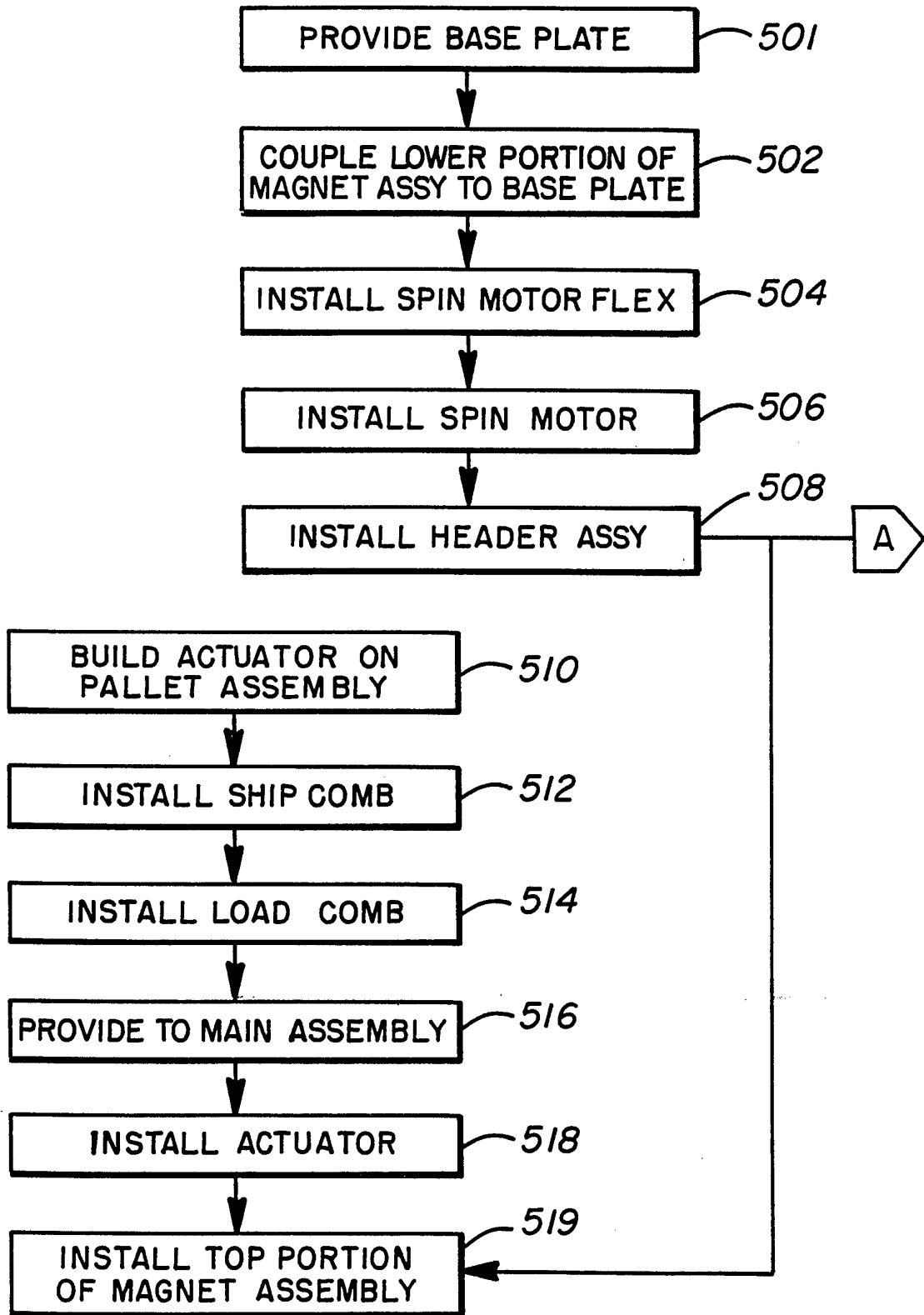

FIG. 23

PART A

34/34

FIG. 23

PART B

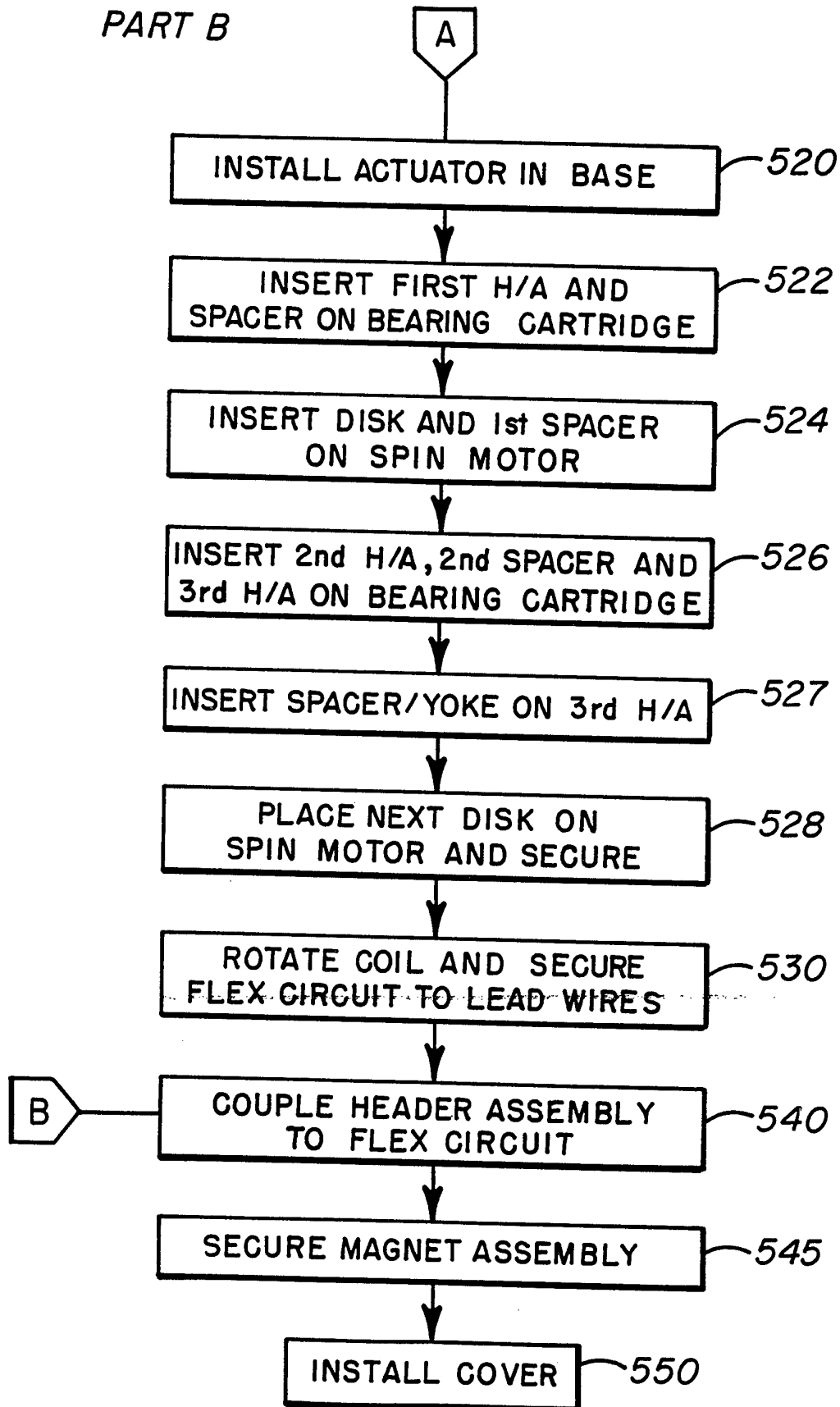

INTERNATIONAL SEARCH REPORT

International application No.
PCT/US 94/12677

A. CLASSIFICATION OF SUBJECT MATTER IPC 6 G11B5/55 G11B5/48				
According to International Patent Classification (IPC) or to both national classification and IPC				
B. FIELDS SEARCHED				
Minimum documentation searched (classification system followed by classification symbols) IPC 6 G11B				
Documentation searched other than minimum documentation to the extent that such documents are included in the fields searched				
Electronic data base consulted during the international search (name of data base and, where practical, search terms used)				
C. DOCUMENTS CONSIDERED TO BE RELEVANT				
Category *	Citation of document, with indication, where appropriate, of the relevant passages	Relevant to claim No.		
X A A	EP,A,0 234 442 (HEWLETT PACKARD CO.) 2 September 1987 see the whole document --- EP,A,0 555 969 (SEAGATE TECHNOLOGY INTERNATIONAL) 18 August 1993 see the whole document --- -/--	1 2-18 1-17		
<input checked="" type="checkbox"/> Further documents are listed in the continuation of box C.				
<input checked="" type="checkbox"/> Patent family members are listed in annex.				
* Special categories of cited documents :				
<table style="width: 100%; border: none;"> <tr> <td style="width: 50%; border: none; vertical-align: top;"> "A" document defining the general state of the art which is not considered to be of particular relevance "E" earlier document but published on or after the international filing date "L" document which may throw doubts on priority claim(s) or which is cited to establish the publication date of another citation or other special reason (as specified) "O" document referring to an oral disclosure, use, exhibition or other means "P" document published prior to the international filing date but later than the priority date claimed </td> <td style="width: 50%; border: none; vertical-align: top;"> "T" later document published after the international filing date or priority date and not in conflict with the application but cited to understand the principle or theory underlying the invention "X" document of particular relevance; the claimed invention cannot be considered novel or cannot be considered to involve an inventive step when the document is taken alone "Y" document of particular relevance; the claimed invention cannot be considered to involve an inventive step when the document is combined with one or more other such documents, such combination being obvious to a person skilled in the art. "&" document member of the same patent family </td> </tr> </table>			"A" document defining the general state of the art which is not considered to be of particular relevance "E" earlier document but published on or after the international filing date "L" document which may throw doubts on priority claim(s) or which is cited to establish the publication date of another citation or other special reason (as specified) "O" document referring to an oral disclosure, use, exhibition or other means "P" document published prior to the international filing date but later than the priority date claimed	"T" later document published after the international filing date or priority date and not in conflict with the application but cited to understand the principle or theory underlying the invention "X" document of particular relevance; the claimed invention cannot be considered novel or cannot be considered to involve an inventive step when the document is taken alone "Y" document of particular relevance; the claimed invention cannot be considered to involve an inventive step when the document is combined with one or more other such documents, such combination being obvious to a person skilled in the art. "&" document member of the same patent family
"A" document defining the general state of the art which is not considered to be of particular relevance "E" earlier document but published on or after the international filing date "L" document which may throw doubts on priority claim(s) or which is cited to establish the publication date of another citation or other special reason (as specified) "O" document referring to an oral disclosure, use, exhibition or other means "P" document published prior to the international filing date but later than the priority date claimed	"T" later document published after the international filing date or priority date and not in conflict with the application but cited to understand the principle or theory underlying the invention "X" document of particular relevance; the claimed invention cannot be considered novel or cannot be considered to involve an inventive step when the document is taken alone "Y" document of particular relevance; the claimed invention cannot be considered to involve an inventive step when the document is combined with one or more other such documents, such combination being obvious to a person skilled in the art. "&" document member of the same patent family			
Date of the actual completion of the international search <p style="text-align: center;">10 March 1995</p>	Date of mailing of the international search report <p style="text-align: center;">06. 04. 95</p>			
Name and mailing address of the ISA European Patent Office, P.B. 5818 Patentlaan 2 NL - 2280 HV Rijswijk Tel. (+31-70) 340-2040, Tx. 31 651 epo nl, Fax (+31-70) 340-3016	Authorized officer <p style="text-align: center;">Moyle, J</p>			

INTERNATIONAL SEARCH REPORT

International application No.
PCT/US 94/12677

C.(Continuation) DOCUMENTS CONSIDERED TO BE RELEVANT		
Category °	Citation of document, with indication, where appropriate, of the relevant passages	Relevant to claim No.
X	<p>DATABASE WPI Week 8933, Derwent Publications Ltd., London, GB; AN 89-239649 ANONYMOUS 'ELECTRICALLY PLUGABLE HSA-ACTUATOR CONFIGURATION FOR HARD DISC DRICE HAS THREE-DIMENSIONAL PRINTED CIRCUIT CONFIGURATIONS APPLIED TO EACH ARM OF ACTUATOR'10 July 1989 see abstract</p> <p style="text-align: center;">---</p>	18
A	<p>US,A,5 063 465 (FUJIOKA) 5 November 1991 see column 3, line 11 - line 30</p> <p style="text-align: center;">---</p>	1-17
A	<p>US,A,5 187 626 (HOPKINS ET AL) 16 February 1993 see abstract</p> <p style="text-align: center;">---</p>	1-17
A	<p>EP,A,0 564 763 (HEWLETT-PACKARD CO.) 13 October 1993 see the whole document</p> <p style="text-align: center;">-----</p>	1-17

INTERNATIONAL SEARCH REPORT

Information on patent family members

International application No.
PCT/US 94/12677

Patent document cited in search report	Publication date	Patent family member(s)	Publication date
EP-A-0234442	02-09-87	US-A- 4716478	29-12-87
		CA-A- 1259696	19-09-89
		JP-A- 62189680	19-08-87
-----	-----	-----	-----
EP-A-0555969	18-08-93	JP-A- 6084302	25-03-94
-----	-----	-----	-----
US-A-5063465	05-11-91	JP-A- 62223867	01-10-87
-----	-----	-----	-----
US-A-5187626	16-02-93	NONE	
-----	-----	-----	-----
EP-A-0564763	13-10-93	US-A- 5363262	08-11-94
		JP-A- 6044702	18-02-94
-----	-----	-----	-----