

(19) World Intellectual Property
Organization
International Bureau



(43) International Publication Date
1 September 2005 (01.09.2005)

PCT

(10) International Publication Number
WO 2005/080477 A2

- (51) International Patent Classification⁷: **C08J 3/075**,
A61L 27/16, C08F 283/01, A61L 15/60, 27/52
- (21) International Application Number:
PCT/US2005/004773
- (22) International Filing Date: 4 February 2005 (04.02.2005)
- (25) Filing Language: English
- (26) Publication Language: English
- (30) Priority Data:
PCT/US04/03135 4 February 2004 (04.02.2004) US
10/771,852 4 February 2004 (04.02.2004) US
- (63) Related by continuation (CON) or continuation-in-part (CIP) to earlier applications:
US PCT/US04/03135 (CIP)
Filed on 4 February 2004 (04.02.2004)
US 10/771,852 (CIP)
Filed on 4 February 2004 (04.02.2004)
- (71) Applicant (for all designated States except US): **CAMBRIDGE POLYMER GROUP, INC.** [US/US]; 52-R Roland Street, Boston, MA 02129-1234 (US).
- (72) Inventors; and
(75) Inventors/Applicants (for US only): **RUBERTI, Jeffrey, W.** [US/US]; 47 School Street, Lexington, MA 02421 (US). **BRAITHWAITE, Gavin J.C.** [GB/US]; 860 Massachusetts Avenue, Unit 850-10, Cambridge, MA 02139-3026 (US).
- (74) Agents: **ZIMMERMAN, Roger, P.** et al.; Bowditch & Dewey, LLP, 161 Worcester Road, Framingham, MA 01701-9320 (US).
- (81) Designated States (unless otherwise indicated, for every kind of national protection available): AE, AG, AL, AM, AT, AU, AZ, BA, BB, BG, BR, BW, BY, BZ, CA, CH, CN, CO, CR, CU, CZ, DE, DK, DM, DZ, EC, EE, EG, ES, FI, GB, GD, GE, GH, GM, HR, HU, ID, IL, IN, IS, JP, KE, KG, KP, KR, KZ, LC, LK, LR, LS, LT, LU, LV, MA, MD, MG, MK, MN, MW, MX, MZ, NA, NI, NO, NZ, OM, PG, PH, PL, PT, RO, RU, SC, SD, SE, SG, SK, SL, SY, TJ, TM, TN, TR, TT, TZ, UA, UG, US (patent), UZ, VC, VN, YU, ZA, ZM, ZW.
- (84) Designated States (unless otherwise indicated, for every kind of regional protection available): ARIPO (BW, GH, GM, KE, LS, MW, MZ, NA, SD, SL, SZ, TZ, UG, ZM,

[Continued on next page]

(54) Title: SYSTEMS AND METHODS FOR CONTROLLING AND FORMING POLYMER GELS

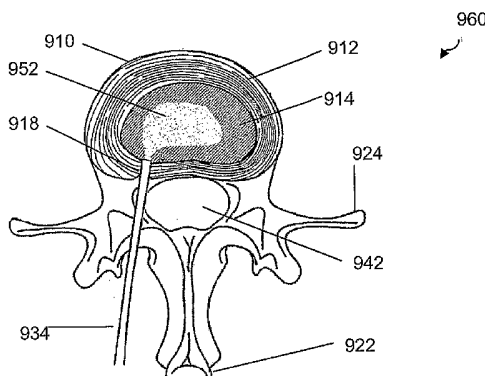

(57) Abstract: In preferred embodiments, the present invention provides methods of controllably making a vinyl polymer hydrogel having desired physical properties without chemical cross links or radiation. The gelation process is modulated by controlling, for example, the temperature of a resultant vinyl polymer mixture having a gellant or using active ingredients provided in an inactive gellant complex. In accordance with a preferred embodiment, the method of manufacturing a vinyl polymer hydrogel includes the steps of providing a vinyl polymer solution comprising a vinyl polymer dissolved in a first solvent; heating the vinyl polymer solution to a temperature elevated above the melting point of the physical associations of the vinyl polymer, mixing the vinyl polymer solution with a gellant, wherein the resulting mixture has a higher Flory interaction parameter than the vinyl polymer solution; inducing gelation of the mixture of vinyl polymer solution and gellant; and controlling the gelation rate to form a viscoelastic solution, wherein workability is maintained for a predetermined period, thereby making a vinyl polymer hydrogel having the desired physical property. In further preferred embodiments, the present invention provides physically crosslinked hydrogels produced by controlled gelation of viscoelastic solution wherein workability is maintained for a predetermined period. In another aspect, the present invention provides kits for use in repairing intervertebral disks or articulated joints including a dispenser and single use containers housing components that form the vinyl polymer hydrogel.

WO 2005/080477 A2



ZW), Eurasian (AM, AZ, BY, KG, KZ, MD, RU, TJ, TM),
European (AT, BE, BG, CH, CY, CZ, DE, DK, EE, ES, FI,
FR, GB, GR, HU, IE, IS, IT, LT, LU, MC, NL, PL, PT, RO,
SE, SI, SK, TR), OAPI (BF, BJ, CF, CG, CI, CM, GA, GN,
GQ, GW, ML, MR, NE, SN, TD, TG).

For two-letter codes and other abbreviations, refer to the "Guidance Notes on Codes and Abbreviations" appearing at the beginning of each regular issue of the PCT Gazette.

Published:

— *without international search report and to be republished upon receipt of that report*

SYSTEMS AND METHODS FOR CONTROLLING AND FORMING POLYMER GELS

CROSS REFERENCES TO RELATED APPLICATIONS

The present application is a continuation-in-part of International Patent
5 Application No. PCT/US04/03135, filed February 4, 2004, and U.S. Patent
Application No. 10/771,852, filed February 4, 2004 which is a continuation-in-part of
U.S. Patent Application No. 10/631,491, filed July 31, 2003 which claims the benefit
of U.S. Provisional Application No. 60/400,899, filed August 2, 2002, the entire
contents of the applications being incorporated herein by reference in their entirety.

10 BACKGROUND OF THE INVENTION

Lower back pain affects over 65 million people in the United States with an
estimated 12 million of these cases arising from degenerative disk disease. The back
is particularly susceptible to damage and disease due to its complex structure. The
spine is a complex structure of articulated bone and cartilage comprised of a column
15 of vertebrae separated by vertebral disks (Fig. 1). These vertebral disks act as an
intervening cushion to mitigate and distribute loads transferred along the spinal
column.

The anisotropic structure of the intervertebral disk efficiently achieves the
appropriate mechanical properties required to cushion complex spinal loads. The
20 inner viscoelastic material, termed the *nucleus pulposus*, occupies 20-40% of the total
disk cross-sectional area. The *nucleus* usually contains between 70-90% water by
weight. The *nucleus* is composed of hydrophilic proteoglycans that attract water into
the *nucleus* and thus generate an osmotic swelling pressure ranging between 0.1-0.3
MPa, which supports the compressive load on the spine. The *nucleus* is constrained
25 laterally by a highly structured outer collagen layer, termed the *annulus fibrosus* (Fig.
1). The *nucleus pulposus* is always in compression, while the *annulus fibrosus* is
always in tension. Although it comprises only one third of the total area of the disk
cross-section, the *nucleus* supports 70% of the total load exerted on the disk. The
intervertebral disk becomes less elastic with age, reaching the elasticity of hard

rubber in most middle-aged adults as the *nucleus* loses water content. This water loss will also cause the disk to shrink in size and will compromise its properties.

In degenerative disk disease, the *nucleus pulposus* can become distorted under stress, resulting in the extrusion of part of the *pulposus* out through the *annulus fibrosus*, causing pressure against the surrounding nerves. This process is called
5 herniation. The damage to the disk can often be irreversible if part of the *pulposus* is lost. The majority of disk injuries occur in the lumbar region, and the most common area of disease occurs at L4/L5 and L5/S1.

A laminectomy (surgical removal of part of a herniated disk - typically the
10 *nucleus pulposus*) may be performed to relieve pressure on local neural tissue. This approach is clearly a short-term solution, given that the load bearing ability of the *nucleus* would be reduced with loss of material. Despite this, over 200,000 laminectomies are performed each year, with a success rate of 70-80%.

Arthrodesis or fusion is a more permanent method for surgically treating
15 degenerative disk disease. Fusion is accomplished with or without internal fixation. While internal fixation has become increasingly popular, this technique has its share of complications. Fracture, neurological damage, and osteoporosis have been observed in patients who have undergone internal fixation fusions. The ability of the bone to fuse will vary from patient to patient, with the average likelihood of success
20 ranging from 75-80%. Spinal fusion will cause stiffness and decreased motion of the spine. Additionally, fusion can also put stress on adjacent vertebrae in the spine, which can accelerate disease in adjacent disks and lead to additional back surgery.

A successfully designed artificial disk would replace a worn out disk while
protecting patients from incurring problems at an adjacent level of the spine. Several
25 artificial disk prostheses have been proposed in the prior art. Many of these prostheses attempt complete replacement of the disk, including the *nucleus* and the *annulus fibrosus*. Given that the intervertebral disk is a complex joint with multi-directional loading, the design of a prosthesis that mimics the articulation and mechanical behavior of a natural disk is extraordinarily difficult. For example, when
30 the body is supine, compressive loading on the third lumbar disk is 300 N, rising to 700 N in an upright stance, then to 1200 N when bending forward by 20°. Additionally, moments of 6 N-m are often achieved during flexion and extension,

with up to 5° of rotation. For adequate safety, a preferred compressive strength of the entire disk is 4 MN/m².

The most extensive experience to date with a complete disk replacement is that obtained with the SB Charité III prosthesis. This prosthesis has been used
5 extensively in Europe since 1987, and has been implanted into over 3,000 patients. The SB III is designed with a polyethylene spacer placed between two cobalt chromium endplates. Two year follow-up studies have shown good clinical success in patients. Another study concerned a complete disk prosthesis consisting of a polyolefin core reinforced with carbon black, which is attached to two titanium
10 plates. Preliminary results are not promising, since the core fractured in 2 of the implants.

Both of the examples presented above serve to indicate that there is considerable commercial effort being expended in the development of artificial disks. However in both cases the mechanical equivalence of these components to the human
15 intervertebral disks is somewhat doubtful and the long-term clinical prognosis is still unclear.

As an alternative to the complete replacement of intervertebral disks, the *nucleus pulposus* alone can be replaced, leaving the *annulus fibrosus* intact. This approach is advantageous if the fibrosis is intact, in that it is less invasive, and the
20 *annulus* can be restored to its natural fiber length and fiber tension. In replacing the *nucleus*, it is desirable to find a material that is similar in properties to the natural *nucleus*. The prior art describes bladders filled with air, saline, or a thixotropic gel. To prevent leakage, the membrane material comprising the bladder must be impermeable, which inhibits the natural diffusion of body fluid into the disk cavity,
25 preventing access to necessary nutrients.

To generate a more natural disk replacement material, several research groups have investigated polymeric hydrogels as a possible replacement for the *nucleus pulposus*. Hydrogels are good analogs for the *nucleus pulposus*, in that they typically possess good viscoelastic properties and can offer good mechanical behavior.
30 Additionally, they contain a large amount of free water, which permits a prosthesis made from a hydrogel to creep under compression and handle the cyclical loading without loss of elasticity, similar to a natural *nucleus pulposus*. The water

permeability of these materials also allows diffusion of body fluid and nutrients into the disk space. Control of this pore structure, and the consequent control of the nutrient access to all parts of the implant, may be critical for future prosthetic implants.

5 Others have investigated the use of polyacrylonitrile-polyacrylamide multiblock copolymers encased in a jacket made from ultra high molecular weight polyethylene fibers. These systems absorb up to 80% of their weight in water. Polyvinyl alcohol (PVA) and copolymers of PVA and poly vinyl pyrrolidone (PVP) have produced prostheses with mechanical properties similar to natural disks. These
10 materials have the additional advantage of having clinical success in other medical devices. Gels formed from PVA are usually prepared via a freeze-thaw process or via external crosslinking agents. In addition, hydrogel-based nuclei can contain therapeutic drugs which slowly diffuse out after implantation. Although no clinical data is currently available for these materials, biomechanical testing on cadaver joints
15 has shown similar mechanical properties to natural disks.

SUMMARY OF THE INVENTION

In preferred embodiments, the present invention provides methods of controlling the gelation kinetics of vinyl polymers. These methods include, in preferred embodiments, controllably making a vinyl polymer hydrogel having desired
20 physical properties without chemical cross links or radiation. The gelation process is modulated by controlling, for example, the temperature of a resultant vinyl polymer mixture having a gellant (also spelled as gelant) or using active ingredients provided in an inactive gellant complex.

Preferred embodiments include an injectable hydrogel such as, for example,
25 for *nucleus pulposus* augmentation using minimally-invasive surgical implantation of prosthetics fabricated *in situ*.

In preferred embodiments, the present invention provides an active gellant and a solution of a vinyl polymer in a single use container. In some preferred
embodiments, the active gellant and the solution of a vinyl polymer are present as a
30 mixture in a single chamber of the single use container. In other preferred

embodiments, the active gellant and the solution of a vinyl polymer are unmixed in separate chambers of the single use container.

Typically, the specific active gellant and vinyl polymer, the amount of active gellant and vinyl polymer solution and the proportion of active gellant and vinyl polymer are selected to produce predetermined rate of gelation, working time, chemical properties, physical properties and volume of the resulting hydrogel. In 5 embodiments in which the active gellant and the solution of a vinyl polymer are provided unmixed in separate chambers of the single use container, the volumes and disposition of the separate chambers within the single use container are selected to accommodate the amount of active gellant and vinyl polymer solution and the 10 proportion of active gellant and vinyl polymer required to produce the predetermined rate of gelation, working time, chemical properties, physical properties and volume of the resulting hydrogel. The elastomeric polymer solution is typically delivered through an appropriately sized needle or cannula.

Typically, in those embodiments in which the active gellant and the solution 15 of a vinyl polymer are provided unmixed in separate chambers of a single use container, the active gellant and the solution of a vinyl polymer are mixed during the step of delivering the viscoelastic polymer solution that is produced by the process of mixing. When the material is extruded from the barrels it is passed through a suitable 20 mixing apparatus (static or dynamic) to ensure that the resulting blend is at least moderately mixed and has a final effective active gellant concentration.

In preferred embodiments, the present invention provides a method of forming a hydrogel component, including the steps of providing a hydrolyzed vinyl polymer solution, providing an active gellant, mixing the active gellant with the 25 hydrolyzed vinyl polymer solution, delivering the mixture of the active gellant with the hydrolyzed vinyl polymer solution into an at least partially enclosed space and allowing the delivered mixture to gel to form a hydrogel within the space. In preferred embodiments, the step of mixing the active gellant with the hydrolyzed vinyl polymer solution produces a viscoelastic polymer solution.

In certain preferred embodiments, the step of mixing the active gellant with 30 the hydrolyzed vinyl polymer solution is performed during the step of delivering the mixture of the active gellant with the hydrolyzed vinyl polymer solution into the

space. In other preferred embodiments, the step of mixing the active gellant with the hydrolyzed vinyl polymer solution occurs before the step of delivering the produced viscoelastic polymer solution into the space.

In further preferred embodiments, the present invention provides a method of forming a hydrogel component including the steps of providing a hydrolyzed vinyl polymer solution, providing an active gellant, mixing the active gellant with the hydrolyzed vinyl polymer solution, allowing the mixture to form a hydrogel, heating the hydrogel to a temperature above the melting point of crosslinks in the hydrogel to form a viscoelastic polymer solution; delivering the viscoelastic polymer solution into an at least partially enclosed space and allowing the delivered mixture to gel to form a hydrogel within the space. In certain preferred embodiments, the step of heating the hydrogel is performed by conduction by direct or indirect contact with a heat source. In other preferred embodiments, the step of heating the hydrogel is performed by the absorption by the hydrogel of infrared or microwave radiation. Preferably the viscoelastic polymer solution is delivered at a temperature of no more than about 50 degrees Celsius. More preferably the viscoelastic polymer solution is delivered at a temperature of no more than about 40 degrees Celsius. Optimally, where the viscoelastic polymer solution is delivered to a body cavity in a vertebrate subject, the viscoelastic polymer solution is delivered at a temperature within a few degrees Celsius of the normal body temperature of the tissue surrounding the body cavity. For example, where the viscoelastic polymer solution is delivered to a body cavity in a human subject, the viscoelastic polymer solution is delivered at a temperature of about 34-40 degrees Celsius, preferably about 37 degrees Celsius. Optionally, controlling the temperature of the delivery system and the elastomeric polymer solution can be used control the solvent quality and thus the process of gelation. The viscoelastic polymer solution can also be cooled to below room temperature prior to delivery.

Generally, the delivered mixture conforms to the space. The space can be enclosed by a natural structure or a manufactured structure, such as a mold. Where the space is enclosed by a mold, the hydrogel component can be produced by injection molding. In certain embodiments, the inner surface of the space is coated with the active gellant before injection of the elastomeric polymer solution, thus

forcing rapid gelation at the edge and thus forming a “skin” that will protect the bulk of the vinyl polymer solution contents during gelation.

Spaces enclosed by natural structures include spaces within geological formations, plants, animal colonies and cavities within animal bodies. Animal body cavities include naturally occurring cavities, potential spaces and cavities caused by developmental defect, pathological condition or trauma. In preferred embodiments, the viscoelastic solution is injected into an actual or potential space in the body of a vertebrate subject. In particularly preferred embodiments, the viscoelastic solution is injected into an intervertebral disk or an articulated joint, such as a hip or knee. In certain preferred embodiments, the viscoelastic solution is injected into a space within the *nucleus pulposus* of an intervertebral disk. In other preferred embodiments, the viscoelastic solution is injected into a space within an articulated joint, such as a hip or a knee. In further preferred embodiments, the viscoelastic solution is injected into an actual or potential subdermal space. The formed hydrogel component can provide tissue bulking or serve as a structural component.

In certain embodiments, the inner surface of a cavity space can be coated with a thin, conforming membrane or barrier that lines the cavity, thus protecting the vinyl polymer solution as it gels thus forming a “skin” that will protect the bulk of the vinyl polymer solution contents during gelation. In some embodiments the lining membrane comprises PVA, suitably a hydrogel formed by the method of the present invention. In certain embodiments, the membrane is permeable or semi-permeable to water. Optionally, the PVA membrane contains an excess of gellant, thus forcing gelation of the delivered viscoelastic polymer solution on contact with the membrane, forming a substantially continuous material. In other embodiments, the cavity is lined with a barrier that is a thin layer of bone wax, preferably bone wax in a phenolic solvent. In general, the lining of the cavity can comprise any ingredient that prevents loss of the ingredients in the polymer solution until gelation has substantially completed, but optimally the lining can comprise any ingredient that causes the vinyl polymer to associate in a controlled manner, or a mixture thereof. The ingredients can be chosen to have similar or different properties (such as solvent activity, diffusion, biodegradability, viscosity). Suitably an ingredient is a water soluble biopolymer or polymer, preferably a polyether, more preferably poly(ethylene glycol).

When poly(ethylene glycol) is used as a gellant, the poly(ethylene glycol) has an average molecular weight in the range of about 100 g/mole to about 20000 g/mole, preferably about 200-2000 g/mole. Poly(ethylene glycol) is typically present in the range of about 1-50 wt%, preferably about 5-40 wt%. In general, a suitable gellant is
5 a bad or poor solvent for PVA, but is easily solvated by water, and when mixed with water, preferentially absorbs water resulting in a poor solvent for PVA.

The hydrogel in accordance with preferred embodiments of the present invention conforms to the region of interest, for example, vertebral surfaces in a joint space. The load bearing hydrogels formed by in situ gelation methods of the present
10 invention minimizes damage to, for example, the annulus fibrosus. In accordance with a preferred embodiment, the method of manufacturing a vinyl polymer hydrogel includes the steps of providing a vinyl polymer solution comprising a vinyl polymer dissolved in a first solvent; heating the vinyl polymer solution to a temperature
elevated above the melting point of the physical associations of the vinyl polymer,
15 mixing the vinyl polymer solution with a gellant, wherein the resulting solvent and gellant mixture combined with the vinyl polymer has a higher Flory interaction parameter than the solvent, and vinyl polymer alone; inducing gelation of the mixture of vinyl polymer solution and gellant; and controlling the gelation rate to form a viscoelastic solution, wherein workability is maintained for a predetermined period,
20 thereby making a vinyl polymer hydrogel having the desired physical property. In further preferred embodiments, the present invention provides physically crosslinked hydrogels produced by controlled gelation of viscoelastic solution wherein workability is maintained for a predetermined period. In another aspect, the present invention provides kits for use in repairing intervertebral disks or articulated joints
25 including components that form the vinyl polymer hydrogel and a dispenser.

In certain preferred embodiments, the step of providing a vinyl polymer solution typically includes the step of dissolving the vinyl polymer in the first solvent. The step of mixing the vinyl polymer solution with a gellant may precede or follow the step of heating the vinyl polymer solution to a temperature elevated above the
30 melting point of physical associations of the vinyl polymer.

The desired physical property typically includes at least one of light transmission, gravimetric swell ratio, shear modulus, load modulus, loss modulus,

storage modulus, dynamic modulus, compressive modulus, cross-linking and pore size. In preferred embodiments, the desired physical property is physical cross-linking.

In preferred embodiments, the vinyl polymer is selected from the group
5 consisting of polyvinyl alcohol, polyvinyl acetate, polyvinyl pyrrolidone and mixtures thereof. Preferably the vinyl polymer is highly hydrolyzed polyvinyl alcohol of about 50 kg/mol to about 300 kg/mol molecular weight. In preferred
embodiments, the vinyl polymer is highly hydrolyzed polyvinyl alcohol of about 100
10 kg/mol molecular weight. Typically the vinyl polymer solution is about 1 weight percent to about 50 weight percent solution of polyvinyl alcohol based on the weight of the solution. In preferred embodiments, the vinyl polymer solution is about 10 weight percent to about 20 weight percent solution of polyvinyl alcohol based on the weight of the solution.

In certain preferred embodiments, the method includes the step of further
15 contacting the viscoelastic solution with a gellant, typically to modify the physical or chemical properties of the resulting gel. This method is suitable for producing a local modification in the physical properties of the gel, such as to maintain the gel in place within a body cavity, such as a space within an intervertebral disk.

In preferred embodiments, the first solvent is selected from the group
20 consisting of deionized water, dimethyl sulfoxide, an aqueous solution of a C₁ to C₆ alcohol and mixtures thereof. Preferably the gellant is more soluble than the vinyl polymer. In certain preferred embodiments, the vinyl polymer is introduced into an aqueous solution of a gellant.

Typically, the Flory interaction parameter of the mixture of vinyl polymer
25 solution and gellant ranges from 0.25 to 1.0. In preferred embodiments, the Flory interaction parameter of the mixture is at least 0.5, more preferably about 0.25 to about 0.5.

Typically the gellant is selected from the group consisting of salts, alcohols, polyols, amino acids, sugars, proteins, polysaccharides, aqueous solutions thereof,
30 and mixtures thereof. In preferred embodiments, the gellant is selected from the group consisting of chondroitin sulfate, dermatan sulfate, hyaluronic acid, heparin sulfate and mixtures thereof. In other preferred embodiments, the gellant is selected

from the group consisting of biglycan, syndecan, keratocan, decorin, aggrecan and mixtures thereof. In further preferred embodiments, the gellant is an alkali metal salt, most preferably sodium chloride.

The gellant may be added as a dry solid or in solution. For example, solid
5 NaCl can be added to an aqueous solution of vinyl polymer, or added as an aqueous solution of sodium chloride from about 1.5 molar to about 6.0 molar, more preferably about 2.0 molar to about 6.0 molar. In further preferred embodiments, the gellant is an aqueous solution of an alcohol chosen from the groups consisting of methanol, ethanol, i-propanol, t-propanol, t-butanol and mixtures thereof.

10 The gellant may be in an active form or an inactive form when it is mixed with the vinyl polymer solution. In preferred embodiments, the step of inducing gelation of the viscoelastic solution includes the step of activating the gellant. Preferably, the inactive gellant is activated by a controllable trigger event.

In certain preferred embodiments, the inactive gellant is a macromolecule and
15 the active gellant comprises fragments of a macromolecule that are released by cleavage of the macromolecule. In some embodiments, the cleavage of the macromolecule is enzymatic cleavage; a preferred macromolecule is a physiological substrate of the selected enzyme. In preferred embodiments, the macromolecule is selected from the group consisting of chondroitin sulfate, dermatan sulfate, keratan
20 sulfate, hyaluronic acid, heparin, heparin sulfate and mixtures thereof and the enzyme is selected from the group consisting of chondroitinase ABC, chondroitinase AC, chondroitinase B, testicular hyaluronidase, hyaluron lyase, heparinase I/III and mixtures thereof. In other preferred embodiments, the macromolecule is selected
25 from the group consisting of biglycan, syndecan, keratocan, decorin, aggrecan, perlecan, fibromodulin, versican, neurocan, brevican and mixtures thereof and the enzyme is selected from the group including, for example, without limitation, aggrecanase and mixtures thereof.

In other embodiments, macromolecule can be thermally denaturable; in such
embodiments, a preferred macromolecule is collagen. Alternatively, cleavage of the
30 macromolecule is by irradiation with electromagnetic radiation or particulate radiation.

In further preferred embodiments, the inactive gellant is a bad solvent sequestered in a vesicle, a liposome, a micelle or a gel particle. In some preferred embodiments, the liposome is a phototriggerable diplasmalogen liposome. In alternate preferred embodiments, the liposome undergoes a phase transition at about
5 the body temperature of a mammal. Preferably, the liposome includes, without limitation, a mixture of dipalmitoylphosphatidylcholine and dimyristoylphosphatidylcholine.

In further preferred embodiments, the inactive gellant is associated with a gel particle that is in an active form upon undergoing a phase transition at about the body
10 temperature of a mammal. In such embodiments, the gel particle suitably comprises a polymer selected from the group consisting of poly(N-isopropyl acrylamide-co-acrylic acid), N-isopropylacrylamide, hyaluronic acid, pluronic and mixtures thereof. In other preferred embodiments, the gel particle releases its contents upon undergoing degradation.

15 Typically, the rate of gelation is controlled to provide an adequate period of workability needed for further processing of the viscoelastic solution, including injecting, molding or calendaring. In preferred embodiments, the viscoelastic solution is injected into an actual or potential space in the body of a mammal. In particularly preferred embodiments, the viscoelastic solution is injected into an
20 intervertebral disk or an articulated joint, such as a hip or knee. The hydrogel can be retained within the body space by virtue of general physical properties or by its local physical properties at the injection site. In preferred embodiments, desired local physical properties can be adjusted by a further addition of gellant near the injection site. In other preferred embodiments, the hydrogel can be retained within the body
25 space by the use of known medical devices to seal, reinforce or close the injection site or other defect of the body cavity. Suitable such devices are disclosed in published International Patent Applications WO 01/12107 and WO 02/054978, which are hereby incorporated by reference in their entirety.

In other preferred embodiments, the step of processing includes covering a
30 burn or a wound.

The preferred embodiments of the present invention provide methods of making a gel and controlling a property of the gel. In accordance with a preferred

embodiment of the present invention, a method for making a gel includes dissolving a vinyl polymer in a first solvent to form a vinyl polymer solution and introducing the vinyl polymer solution in a volume of a second solvent to cause gelation, the second solvent having a higher Flory interaction parameter at a process temperature than the first solvent. The Flory interaction parameter (χ) is dimensionless and depends on, for example, temperature, concentration and pressure. Solvents can be characterized as having a low χ value or solvents having a higher χ value wherein $\chi=0$ corresponds to a solvent which is similar to a monomer. A solvent having a higher χ value is characterized as a solvent that causes a gelation process at a temperature. A thetagel, in accordance with the present invention, is formed by using a second solvent having a Flory interaction parameter that is sufficient to cause gelation.

Preferably the second solvent used in the preferred embodiment has a Flory interaction parameter in the range of 0.25 to 1.0. Typically, first and second solvent characteristics are chosen to allow use of the method of the preferred embodiment at room temperature or at body temperature of a mammal. The gel produced by the method of the invention has physical cross-linking, and is substantially free of chemical crosslinking agents. In a preferred embodiment, the vinyl polymer is polyvinyl alcohol.

In some embodiments, a plurality of cycles of contacting the vinyl in an immersion solvent (second solvent) and contacting with the first solvent are performed. Alternatively, the method may include subjecting the gel to at least one freeze-thaw cycle. The polyvinyl alcohol (PVA) hydrogels thus may be both a thetagel and a cryogel. Partial gelling can be accomplished with either method and then completed using the other, or even alternating between the two methods.

While the examples and discussion herein are directed towards vinyl polymers and in particular PVA hydrogels, thetagels can be made in a similar manner using any polymer that possesses the appropriate kind of phase diagram as described hereinafter with respect to the Flory interaction parameter. A mechanical force can be applied to the gel during the gelling process, changing the manner in which it gels and alternatively producing oriented gelation.

In several embodiments, the vinyl polymer is highly hydrolyzed polyvinyl alcohol of about 50 kg/mol to about 300 kg/mol molecular weight. In other

embodiments, the vinyl polymer is highly hydrolyzed polyvinyl alcohol of about 100 kg/mol molecular weight. The vinyl polymer solution is about 1 weight percent to about 50 weight percent solution of polyvinyl alcohol based on the weight of the solution. Preferably, the vinyl polymer solution is about 10 weight percent to about 5 20 weight percent solution of polyvinyl alcohol based on the weight of the solution.

The first solvent is selected from the group of solvents having a low χ value that is not sufficient to enable gelation, i.e., solvents in which the energy of interaction between a polymer element and a solvent molecule adjacent to it exceeds the mean of the energies of interaction between the polymer-polymer and the solvent-10 solvent pairs, as discussed below. In several embodiments, the first solvent is selected, without limitation, from the group consisting of deionized water, dimethyl sulfoxide, an aqueous solution of a C₁ to C₆ alcohol and mixtures thereof.

In general, the immersion solution comprises a solvent having a high or sufficient χ value that enables gelation. In some preferred embodiments, the15 immersion solution is an aqueous solution of a salt of an alkali metal, typically sodium chloride. In other embodiments, the immersion solution is an aqueous solution of a C₁ to C₆ alcohol, typically an aqueous solution of an alcohol chosen from the groups consisting of methanol, ethanol, i-propanol, t-propanol, t-butanol and mixtures thereof. In certain embodiments, the immersion solution is an aqueous20 solution of methanol.

In general, the vinyl polymer gels of the present invention can be made *in-situ* for applications such as filters, microfluidic devices or drug release structures in situations in which freeze-thaw gelation may be difficult or impossible to execute.

In one embodiment, the vinyl polymer solution is placed in a chamber having25 at least two sides and a membrane. The membrane has properties that contain the vinyl polymer while providing access to small molecules and solvents.

In some embodiments, the vinyl polymer solution is separated by the membrane from at least two different immersion solvents, typically a first immersion solvent and a second immersion solvent. In some embodiments, the first immersion30 solvent is an aqueous solution of sodium chloride from about 1.5 molar to about 6.0 molar. In some embodiments, the second immersion solvent is an aqueous solution of sodium chloride from about 2.0 molar to about 6.0 molar. In other embodiments,

the first immersion solvent is a 1.5 molar aqueous solution of sodium chloride and the second immersion solvent is an aqueous solution of sodium chloride from about 2.0 molar to about 6.0 molar. In such embodiments, a gradient in chemical potential is formed across the vinyl polymer solution between at least two different immersion solvents. In one embodiment, a gradient in chemical potential is formed across the vinyl polymer solution of about 4 mol.cm^{-1} .

In general, a gradient of a property is formed across the vinyl polymer gel that corresponds to the gradient in chemical potential formed across the vinyl polymer solution. Typically, the property is at least one of light transmission, swell ratio, shear modulus, load modulus, loss modulus, storage modulus, dynamic modulus, compressive modulus, cross-linking and pore size.

In some embodiments, one or both immersion solvents are changed in a temporal pattern to modulate the spatial gradient of a physical property. Such temporal cycling is done on a time scale shorter than the diffusion time to make an inhomogeneous gel. In this way, gels can be produced with a similar set of properties on the edges or peripheral region and another set of properties in the central region, such as greater cross-linking in the peripheral region as compared with the central region. Temporal cycling of immersion solvents can also be used to modify the structure of the gel, for example, pore size, for production of filters. In such filters, small, locally varying pore size may be useful for some forms of chromatography (through size exclusion) or any other filtering application that requires pore size control.

Additional compounds can be combined in the physically cross-linked gel, including but not limited to, ionic or non-ionic species such as hyaluronic acid, polyacrylic acid and therapeutic agents.

In one embodiment, the invention provides a physically cross-linked hydrogel comprising at least about 10 weight percent poly(vinyl alcohol) solution gelled by immersion in about 2 to about 3 molar sodium chloride wherein the hydrogel is about 14 percent to about 21 percent physically cross-linked. In such an embodiment the final gel comprises about 12 to about 29 percent poly(vinyl alcohol).

The preferred embodiments of the present invention also provide articles of manufacture comprising a vinyl polymer gel having at least one gradient of

mechanical properties. PVA thetagels may be used as a biocompatible load bearing or non-load bearing material for replacement, repair or enhancement of tissue. In general, PVA thetagels can replace PVA cryogels in applications where PVA cryogels are used.

5 In one embodiment, a one-piece prosthetic intervertebral disk is made comprising a polyvinyl polymer hydrogel wherein the distribution of mechanical properties of the one-piece prosthetic intervertebral disk approximates the spatial distribution of the mechanical properties of the combination of the *nucleus pulposus* and the *annulus fibrosus* of the natural intervertebral disk.

10 High compression PVA thetagels can be made by placing PVA in a reverse osmosis membrane with NaCl and then making the outside concentration of NaCl quite high to compress PVA/NaCl. The NaCl concentration will climb as water leaves the reverse osmosis membrane gelling the PVA at high pressure. The concentration of PVA can be modified by the ratio of NaCl to PVA inside the reverse
15 osmosis membrane.

In a preferred embodiment, gel microparticles can be made through gelation during agitation or by dropping blobs of fluid into a crosslinking solvent, such as the immersion solution.

In a preferred embodiment, gels can be embedded with particles that degrade
20 (or do not adsorb) to “imprint” a pattern (“empty spaces”) on the gel or as the drug release centers. Embedding neutrally charged polymers of varying molecular weights can be used to “space fill” the gel. These polymers are removable after the process, leaving a controlled pore structure. Materials that are sensitive to freeze-thaw cycles can be encapsulated. The gels can be embedded with particles or polymers that are
25 electrostatically charged to provide extra repulsion at high compressions but are collapsed in high salt. Such embedded particles can be those that are active in some manner (e.g. for catalyses). Hydroxyapatite particles or other osteoinductive particles, agents, and similar moieties can be embedded to encourage bony ingrowth for possible cartilage replacement.

30 In a preferred embodiment, poly(vinyl alcohol) gels can be used to contain and release bio-active compounds such as growth factors, fibronectin, collagen, vinculin, chemokines and cartilage including therapeutic agents. The teachings with

respect to incorporation of therapeutic agents of U.S. Patents 5,260,066 and 5,288,503 are herein incorporated in their entirety. Contained compounds such as therapeutic agents or drugs can be released over time to modulate the local growth of normal tissues such as bone, blood vessels and nerves or tumors.

5 Temporal modulation of immersion solvents can produce the gels in accordance with the preferred embodiment with appropriate structure and physical properties for containing and releasing drugs and other bioactive molecules. In one embodiment, an outer skin is formed that is highly crosslinked and an inner layer containing the drug/active agent is only weakly crosslinked. In such an embodiment,
10 the outer skin is the rate limiting component and has a constant release rate. Thus, drug release in accordance with a preferred embodiment includes the release profile that is tunable by controlling the spatial gradient in PVA crosslinking.

In one embodiment, the present invention provides a method of controllably modulating the mechanical properties and structure of hydrogels. In a preferred
15 embodiment, the present invention provides articles of manufacture with one or more gradients of mechanical properties that more closely match the existing gradients of such properties in natural structures. In one embodiment the invention provides prosthetic hydrogel articles of manufacture that mimic the mechanical behavior of natural structures. In a preferred embodiment, the invention provides polyvinyl
20 alcohol prosthetic intervertebral disks that mimic gradients of mechanical properties found in the natural intervertebral disks. In another preferred embodiment, the invention provides a one-piece prosthetic intervertebral disk that mimics the spatial distribution of the mechanical properties of the *nucleus pulposus* plus *annulus fibrosis* of the natural intervertebral disk.

25 In a preferred embodiment, particulates may also be added to the gel. As described hereinbefore, particulates can be added to create a controlled pore structure. Further, in accordance with another preferred embodiment, particulates can be added to provide a particular nanostructured gel. The particles can be either charged or uncharged and allow PVA crystals to nucleate at the surface of the particles. Particles
30 that can be added include, but are not limited to, inorganic or organic colloidal species such as, for example, silica, clay, hydroxyapatite, titanium dioxide or polyhedral oligomeric silsesquioxane (POSS).

In accordance with another preferred embodiment, particles are added to provide a charge effect to change the compressive modulus of the gel, and preferably increase the compressive modulus. This embodiment can use a thetagel having added particles. Upon compressing the gel in a salt solution, a structure having particles
5 with close packing while shielding their charges results. Upon rehydrating with, for example, deionized (DI) water, the charge fields expand and results in a gel in tension. This allows the gel to approximate physical properties of cartilage, for example, at high charged particulate loads.

In accordance with another preferred embodiment, particulates are added to
10 the gel structure to provide mechanical properties such as, for example, wear resistance. The addition of hardened glass (silica) or different clays can provide wear resistance to the gels.

In accordance with another preferred embodiment of the present invention, a method for making a gel and controlling a property of the gel includes forming a
15 thetagel as described hereinbefore by using a first solvent to form a vinyl polymer solution and subsequently introducing a volume of a second solvent to cause gelation, followed by promoting dehydration to controllably structure the gel. This method results in uniformly structuring the gel and homogenizing the physical crosslinking of the PVA thetagel. This structure can be achieved by immersing the contained PVA
20 solution into a solvent which has a Flory interaction parameter that is higher than the theta point for the PVA solvent pair, and subsequently immersing the contained PVA in another solvent having a Flory interaction parameter lower than the theta point for the PVA solvent pair. The process can continue with successive decreases in the Flory interaction parameter until the desired interaction parameter value for the gel is
25 reached.

In another method in accordance with a preferred embodiment of the present invention, the PVA solution can be subjected to a gradually changing solvent quality through a similar range of electrolyte concentrations by the gradual addition of a concentrated NaCl solution to deionized water such that the change of the salt
30 concentration is slower, or equal, to the diffusion process of the gel.

In accordance with another preferred embodiment of the present invention, the PVA solution may be subjected to at least one freeze-thaw cycle to fix the gel into a

particular shape and then be immersed in a series of solutions with successively higher Flory interaction parameters until the final desired Flory parameter is reached. Alternatively, the PVA solution is subjected to the one or more freeze-thaw cycles after being immersed in a solution of 2 M NaCl.

5 In one preferred embodiment, nanoparticles are dispersed into solutions of PVA. The solvent may be water, dimethyl sulfoxide (DMSO), methanol or any other solution that exhibits a Flory interaction parameter that is lower than the theta point for the PVA solvent pair during solution preparation. The PVA/nanoparticle mixture is then subjected to at least one freeze-thaw cycle. Subsequent to the freeze-thaw
10 cycling, the gelled PVA is immersed in a solvent that has a Flory interaction parameter near or higher than the theta point for the PVA/solvent pair to induce further physical crosslinking of the PVA/nanoparticle mixture.

Another aspect of the embodiments of the present invention further provide methods of controlling the rate of gelation of polymer gels by changing in the manner
15 in which the polymer molecules interact. By controlling the rate of gelation, a "window" of time that allows the relatively slowly gelling PVA solution to be manipulated or worked, for example, by injection, molding or any other processing step that may be dependent on the flow of the gelling PVA solution. In preferred
20 embodiments, the gelling PVA solution is injected into a region of interest such as a body cavity and gels *in situ* to form a PVA product. Preferred body cavities include the *nucleus pulposus* and a normal or pathological void within a joint.

In preferred embodiments, the rate of gelation can be controlled by holding the polymer, preferably PVA, above its crystallization temperature, thus preventing gelation even if the solvent quality is poor. In other preferred embodiments, the rate
25 of gelation can be controlled by using a second solvent that can be triggered to change from good to bad. In some preferred embodiments, the quality of the solvent can be changed by disruption of micelles. In other preferred embodiments, the quality of the solvent can be changed scission of high molecular weight molecules. In further preferred embodiments, a poor solvent is used in combination with process
30 temperatures that accelerate the gelation process.

The foregoing and other features and advantages of the systems and methods for controlling and forming polymer gels will be apparent from the following more

particular description of preferred embodiments of the system and method as illustrated in the accompanying drawings in which like reference characters refer to the same parts throughout the different views. The drawings are not necessarily to scale, emphasis instead being placed upon illustrating the principles of the invention.

5. BRIEF DESCRIPTION OF THE DRAWINGS

Figs. 1A and 1B are a diagrammatic representation of spinal anatomy showing transverse process, spinous process and vertebral body of the vertebral bones, the spinal cord and spinal nerves, and the *nucleus pulposus* of the intervertebral disks. The *annulus fibrosus* of the intervertebral disk surrounds the *nucleus pulposus* on lateral, anterior and posterior sides.

Fig. 2 is a graphical representation of the relationship of the Flory interaction parameter, χ , to the concentration (Φ) of a polymer at a given temperature in accordance with preferred embodiments of the present invention. The abscissa, at $\chi = 0.25$, separates polymer solutions in first solvents (below) and polymer solutions in second solvents (above). The arrows and diamonds indicate the effect on χ produced by replacing solvent 1 with solvent 2.

Fig. 3 shows 10% PVA solution in dialyzer cassettes after 1 day (top) and 3 days (bottom) of immersion in curing solution in accordance with a preferred embodiment of the present invention. From left to right: 1.5 M NaCl, 2.0 M NaCl and 3.0 M NaCl. The 1.5 M solution does not gel the PVA, the 2.0 M solution and 3.0 M solution do gel the PVA. Note the progressive opacification of the 2.0 M gel and the shrinkage of the 3 M gel from the edges of the cassette as the sample compacts with time (indicated with arrow).

Fig. 4 shows a uniform thetagel in accordance with a preferred embodiment of the present invention. PVA gels generated by immersion in 3.0 M (left image of each pair) and 2.0 M (right image) NaCl curing solution. Note that the gels are uniform and opaque. The gel exposed to 3.0 M NaCl swells less and is more compact following equilibration in deionized water.

Fig. 5 shows an example of a gradient gel in accordance with a preferred embodiment of the present invention using a 10% PVA solution exposed to spatially

varying NaCl concentration. Note the variation in both the translucency of the gel and in the swelling ratio.

Fig. 6 shows a differential scanning calorimetry (DSC) thermogram comparing the results obtained with a thermally cycled PVA cryogel and the "thetagel" in accordance with a preferred embodiment of the present invention. The solid line is indicative of 10% PVA immersed in 3.0 M NaCl for 3 days; the dashed line is indicative of 10% PVA thermally cycled 4 times from 10 degrees Celsius to -20 degrees Celsius with a warming rate of 0.02 degrees Celsius/min.

Fig. 7 graphically illustrates the relationship between the percentage of PVA in PVA hydrogels that were fully equilibrated in deionized water after being gelled in immersion solutions of different molarities in accordance with a preferred embodiment of the present invention. The connected points represent measurements of 10% PVA immersed for 3 days, the single point represents an initial solution of 20% PVA solution immersed in 3 M NaCl for 12 days. For the 20% PVA solution, the 3 day value of swelling ratio and percentage of PVA matched that of the 10% PVA solution (not shown). After 12 days of immersion in 3 M NaCl (and 5 days of equilibration in deionized water), the 20% PVA solution formed a gel that was 29% PVA.

Fig. 8 graphically illustrates the gravimetric swelling ratio for PVA hydrogels that were fully equilibrated in deionized water after being gelled in immersion solutions of different molarities in accordance with a preferred embodiment of the present invention. The connected points represent measurements of 10% PVA immersed for 3 days, the single point represents an initial solution of 20% PVA solution immersed in 3 M NaCl for 12 days. For the 20% PVA solution, the 3 day value of swelling ratio and percentage of PVA matched that of the 10% PVA solution (not shown).

Fig. 9 shows the dynamic modulus of PVA thetagel at 3 M NaCl, 20% initial PVA concentration and 1 N static load versus aging time in days in accordance with a preferred embodiment of the present invention.

Fig. 10 shows the complex modulus (Storage (G') and Loss (G'') Modulus) of PVA thetagel at 20% initial PVA concentration and 0.25 N static load against

solution molarity (2M and 3M NaCl) in accordance with a preferred embodiment of the present invention.

Fig. 11 is a schematic diagram of an "Ussing" type chamber used to create a gradient gel 160 in accordance with a preferred embodiment of the present invention.

5 Fig. 12 illustrates a quick freeze deep etch (QFDE) image of PVA gel structure in accordance with a preferred embodiment of the present invention wherein the PVA gel is formed by immersion in 5 M NaCl for 3 days. The bar represents 100 nm.

10 Figs. 13A and 13B are a cross-sectional and a close-up view of the cross-section of a PVA gradient hydrogel, respectively, prepared by filling Plexiglass tubing with 10% PVA solution, performing one freeze thaw cycle (8 hours at -21°C ; 4 hours at room temperature) then immersing in 3 M NaCl bath for at least 3 days, then dehydrating in air for 60 hours and returning to deionized (DI) water in accordance with a preferred embodiment of the present invention.

15 Fig. 14 illustrates a cross-sectional view of a PVA gradient hydrogel prepared by filling dialysis cartridge with 10% PVA solution, then immersing in a chamber having 3 M NaCl on one side and 6 M NaCl on the other side for 3 days in accordance with a preferred embodiment of the present invention.

20 Fig. 15 illustrates a close-up view of the cross-section of the PVA gradient hydrogel of Fig. 14 on the 6 M NaCl side prepared by filling the dialysis cartridge with 10% PVA solution, and then immersing in a chamber with 3 M NaCl on one side and 6 M NaCl on the other for 3 days.

25 Fig. 16 illustrates a nanostructured PVA hydrogel prepared by mixing a solution of 10% PVA and 2 weight percent Laponite clay, subjecting to a 1 freeze-thaw cycle, then exposing to a 4 M NaCl solution for at least 3 days in accordance with a preferred embodiment of the present invention.

30 Fig. 17 illustrates a nanostructured PVA hydrogel prepared by mixing a solution of 10% PVA and 4 weight percent of silica, titrating to $\text{pH} = 3$, subjecting to a 1 freeze-thaw cycle, then exposing to a 4 M NaCl solution for at least 3 days in accordance with a preferred embodiment of the present invention.

Fig. 18 illustrates a nanostructured PVA hydrogel prepared by mixing a solution of 10% PVA and 4 weight percent silica, titrating to $\text{pH} = 10$, subjecting to 1

freeze-thaw cycle, then exposing to 4 M NaCl solution for at least 3 days in accordance with a preferred embodiment of the present invention.

Fig. 19 illustrates a nanostructured PVA hydrogel prepared by mixing a solution of 10% PVA and an octatetramethylammonium polyhedral oligomeric silsesquioxane (OctaTMA POSS) in water, then subjecting to 1 freeze-thaw cycle in accordance with a preferred embodiment of the present invention.

Fig. 20 graphically illustrates the storage modulus for hybrid and control PVA gels in accordance with a preferred embodiment of the present invention.

Fig. 21A illustrates a flow chart of a method of forming a PVA hydrogel in accordance with a preferred embodiment of the present invention.

Fig. 21B illustrates a flow chart of methods of forming and providing a vinyl polymer hydrogel in accordance with preferred embodiments of the present invention.

Figs. 22A-22D illustrate a PVA hydrogel prepared by adding 1.4 g of 400 molecular weight poly(ethylene glycol) (PEG 400, Sigma Aldrich) to 6 g of an aqueous 10 wt% PVA solution while mixing, in accordance with a preferred embodiment of the present invention, showing the product at four time durations after the end of mixing: Fig. 22A, zero minutes; Fig. 22B, 15 minutes; Fig. 22C, 2 hours, under a mineral oil protective layer; and Fig. 22D, one day, out of a jar.

Figs. 23A-23E illustrate a PVA hydrogel prepared by adding 35.6 g of aqueous 10 wt% PVA solution to 18.7 g of aqueous 5.1 M NaCl while mixing, and the resulting mixture aggressively shaken, in accordance with a preferred embodiment of the present invention, showing the product at five time durations after pouring into a covered dish and a flexible bag: Fig. 23A, zero minutes; Fig. 23B, 20 minutes; Fig. 23C, 1 hour; Fig. 23D, 2 hours; and Fig. 23E, 17 hours.

Figs. 24A-24F illustrate a PVA hydrogel prepared by adding NaCl to aqueous 10 wt% PVA solution at about 95 degrees Celsius (Fig. 24A) while mixing to make a final concentration of 2M NaCl (Fig. 24B), in accordance with a preferred embodiment of the present invention. After mixing for 15 minutes, aliquots of the resulting mixture were poured into two containers that were cooled at room temperature (Fig. 24C, 15 minutes; Fig. 24E, one hour) or on shaved ice (Fig. 24D, 15 minutes; Fig. 24F, one hour).

Figs. 25A-25F illustrate the PVA hydrogels of Figs. 24A-24F after storage. Fig. 25A, cooled one hour at room temperature and stored 12 hours at room temperature; Fig. 25B, cooled one hour on ice and stored 12 hours at room temperature; Fig. 25C, cooled one hour at room temperature and stored one month at room temperature; Fig. 25D, cooled one hour on ice and stored one month at room temperature; Fig. 25E, the PVA gel of Fig. 25C, oriented to show water released due to syneresis; and Fig. 25F, the PVA gel of Fig. 25D, oriented to show water released due to syneresis.

Figs. 26A-26D illustrate a PVA hydrogel prepared by adding NaCl to aqueous 10 wt% PVA solution at 95 degrees Celsius while mixing to make a final concentration of 2.1M NaCl, in accordance with a preferred embodiment of the present invention, wherein Fig. 26A shows a mold formed by a chilled polyethylene liner and the matching ball from a total hip replacement joint, Fig. 26B shows the mold after filling the chilled polyethylene liner with the PVA solution and putting the matching ball in place, Fig. 26C shows the molded PVA in the polyethylene liner after one hour in air at room temperature followed by one hour in deionized water at room temperature; and Fig. 26D shows the molded PVA product removed from the polyethylene liner.

Figs. 27A-27B illustrate PVA hydrogels incorporating chondroitin sulfate (CS) prepared in accordance with preferred embodiments of the present invention, where Fig. 27A shows a PVA hydrogel formed by adding warm CS solution at about 80 degrees Celsius to a aqueous 10 wt% PVA solution at about 60 degrees Celsius to produce a 5 wt% PVA, 7 wt% CS mixture and Fig. 27B shows a PVA hydrogel formed by adding 600 mg CS directly to 10 ml aqueous 10 wt% PVA solution.

Figs. 28A-28C illustrate flow charts of methods for forming a PVA hydrogel in accordance with preferred embodiments of the present invention.

Figs. 29A-29F schematically illustrate a method for forming and dispensing a vinyl polymer hydrogel in accordance with a preferred embodiment of the present invention.

Figs. 30A-30F schematically illustrate a method for forming and dispensing a vinyl polymer hydrogel in accordance with an alternate preferred embodiment of the present invention.

Figs. 31A-31E schematically illustrate a method for forming and dispensing a vinyl polymer hydrogel in accordance with an alternate preferred embodiment of the present invention.

5 Fig. 32A schematically illustrates a dispenser for providing a vinyl polymer hydrogel in accordance with a preferred embodiment of the present invention.

Fig. 32B schematically illustrates a dispenser for providing a vinyl polymer hydrogel in accordance with another preferred embodiment of the present invention.

Fig. 33 illustrates a midsagittal cross-section of a portion of a functional spine unit in which two vertebrae and the intervertebral disk are visible.

10 Fig. 34 illustrates a transverse section through a damaged intervertebral disk, showing a spinous process and transverse process of an adjacent vertebra, *annulus fibrosis* and, *nucleus pulposus*.

Fig. 35 illustrates a step of dispensing a mixture of gellant and vinyl polymer in a method for repairing a damaged intervertebral disk in accordance with a preferred embodiment of the present invention.

15 Fig. 36 illustrates a step in a method for repairing a damaged intervertebral disk in accordance with a preferred embodiment of the present invention showing, in particular, a mixture of gellant and vinyl polymer, a sealant, a fixative, and the fixative delivery instrument.

20 Fig. 37 illustrates a step in a method for repairing a damaged intervertebral disk in accordance with a preferred embodiment of the present invention showing, in particular, a mixture of gellant and vinyl polymer, barrier, a fixative, and a fixative delivery instrument.

25 Fig. 38 A illustrates a step in a method for repairing a damaged intervertebral disk in accordance with a preferred embodiment of the present invention showing, in particular, the mixture of gellant and vinyl polymer substantially filling the space previously occupied by the *nucleus pulposus*, a barrier, and a dispensing tube.

30 Fig. 38 B illustrates a step of dispensing a mixture of gellant and vinyl polymer in a method for repairing a damaged intervertebral disk in accordance with a preferred embodiment of the present invention, showing a cooling probe 936 adjacent to the dispensing tube 934.

Fig. 39 illustrates a group 1000 of vials containing PVA hydrogels prepared from various concentrations of PVA (3, 5, 7.5, and 10% weight percent relative to water component) and gelled with 20 % polyethylene glycol (400 g/mole, weight percent relative to water) as gellant. The hydrogels formed from 3 weight percent PVA 1002, 5 weight percent PVA 1004 and 7.5 weight percent PVA 1006 showed similar opacity, consistent with the similar PVA concentration in the final hydrogel; see Table 3. In contrast, the hydrogel formed from 10 weight percent PVA 1008 appeared more opaque and had a relatively higher PVA concentration in the final hydrogel; see Table 3.

Fig. 40 is a graphical illustration of the results of a study in which a 10% PVA freeze-thaw gel was placed in various concentrations of PEG of number of molecular weights (open triangles = 200 g/mole, filed circles = 400 g/mole, open squares = 600 g/mole, filled triangles = 1000 g/mole, filled diamonds = 1500 g/mole and filled squares 20,000 g/mole) as well as a solution of NaCl (open circles). Curves that are further to the left on the plot indicate that the active ingredient required less mass to obtain the same swelling (and hence solvent quality) behavior.

Fig. 41 is a graphical illustration of the results of a study of Fig.40 plotted to show the concentration of PEG of a given molecular weight that would be equivalent in effect to a 20 weight percent solution of PEG 400.

Fig. 42 is a portion of radiograph 1100 of a portion of a porcine vertebral column, showing an intervertebral disc 910 bounded by the vertebral bodies 1102, 1104 of adjacent vertebrae and showing radiopaque hydrogel 1120 that was injected into the evacuated nucleus cavity of the intervertebral disc 910.

Fig. 43 is a photograph 1200 of a dissected portion of a porcine vertebral column, showing an intervertebral disc 910, *annulus fibrosis* 912, evacuated *nucleus pulposus* cavity 1212, and a cast of radiopaque hydrogel 1220 that was removed from the evacuated nucleus cavity 1212, and shown resting on a scalpel blade 1202.

DETAILED DESCRIPTION OF PREFERRED EMBODIMENTS

The preferred embodiments of the present invention are directed at the generation of uniform PVA hydrogels without chemical crosslinks or irradiation to produce a biocompatible material suitable for use as, for example, an intervertebral

disk prosthesis. Further, a preferred embodiment of the present invention includes a method used to create the PVA gels that result in a new class of PVA hydrogels which can be designed for specific applications to have a potentially large range of mechanical properties, being controllable, and which can be engineered with
5 gradients in structure and physical properties.

As used herein, "theta solvent" refers to a solvent that yields, at the theta temperature, solutions of a polymer in the theta state. Theta solvents may be composed of a single solvent or mixture of two solvents, a mixture of a solvent and a nonsolvent, or even a mixture of two nonsolvents in the case of co-solvency as
10 described by Elias, H.G., "Theta Solvents," in Brandrup, J. and E.H. Immergut, Polymer Handbook 3rd Ed., John Wiley and Sons, New York, 1989, the teachings of which are herein incorporated by reference in their entirety.

As used herein, "gelation" refers to the formation of permanent physical cross-links due to the crystallization of the PVA. This is in contrast to some of the
15 literature in which gelation refers to the point at which the polymer associates, and need not be followed by the crystallization that forms a permanent link.

As used herein, "associate" refers to a thermodynamically, or solvent, driven process whereby the polymer (or other species) "prefers" to be in an environment similar to itself, rather than in close proximity to another species. This association of
20 the polymer locally then necessarily leads to a "phase separation" that may or may not lead to an inhomogeneous solution.

While not being held to a particular theory, it is thought that forcing poly(vinyl alcohol) polymer chains in solution into close proximity using a theta solvent through a spinodal decomposition mechanism results in the formation of a
25 physical association that is resistant to dissolution. As used herein, spinodal decomposition refers to a clustering reaction in a homogeneous, supersaturated solution (solid or liquid) that is unstable against infinitesimal fluctuations in density or composition. The solution therefore separates spontaneously into two phases, starting with small fluctuations and proceeding with a decrease in the Gibbs energy
30 without a nucleation barrier.

The methodology used in the present invention generates a PVA hydrogel employing the controlled use of solvents having a χ value sufficient to cause gelation

to force the PVA chains to physically associate. To prevent random "crashing out" of the PVA, it is critical that the solvent quality is controlled carefully, and, in particular for larger components, that the solvent "front" enters the PVA solution in a controlled manner. For example, NaCl/deionized (DI) water and methanol/deionized water
5 solutions at temperatures and concentrations in the neighborhood of their "theta" value for PVA were used to force the physical association and subsequent gelling of the PVA. Gels formed in this way are called "thetagels" herein.

In general, by controlling solvent quality one can create a "window" of time that allows the relatively slowly gelling PVA solution to be manipulated or worked.
10 This manipulation includes, without limitation, injection or molding or any other conceivable processing step.

The methods are applicable to the creation of materials for use in medical, biological and industrial areas including the controlled delivery of agents (which may include proteins, peptides, polysaccharides, genes, DNA, antisense to DNA,
15 ribozymes, hormones, growth factors, a wide range of drugs, imaging agents for CAT, SPECT, x-ray, fluoroscopy, PET, MRI and ultrasound), generation of load bearing implants for hip, spine, knee, elbow, shoulder, wrist, hand, ankle, foot and jaw, generation of a variety of other medical implants and devices (which may include active bandages, trans-epithelial drug delivery devices, sponges, anti-
20 adhesion materials, artificial vitreous humor, contact lens, breast implants, stents and artificial cartilage that is not load bearing (i.e., ear and nose)), any application where gradients (single or multiple) in mechanical properties or structure are required.

The mechanism of gel formation includes a phase separation usually considered to be a spinodal decomposition process followed by a crystallization
25 mediated by hydrogen bonding in the PVA rich regions of the solution. The choice of the solvent is known to influence the freeze-thaw process. It is also known that some solvents can be used to gel PVA without dropping the temperature of the solution below the freezing point of the solvent. Solvents such as DMSO, ethylene glycol (EG), N-methyl-2-pyrrolidone (NMP), and gelatin have been used to gel PVA in
30 ambient temperatures. The preferred embodiments of the present invention include the use of salt as a means of gelling a PVA solution, and the utility of manipulating and controlling the solvent quality during the gelation process.

An ideal polymer chain in a good solvent has no association behavior that leads to precipitation. As the solvent quality drops below the theta condition, the chains begin to prefer to associate until eventually the polymer phase separates. In an ideal polymer, there are no further interaction forces in the polymer chains, other than that provided through thermodynamic (solvent) forces, and the normal, reversible phase diagram thus applies. However, in PVA, there is a strong binding force driven by hydrogen bonding that results in a local crystallization of the chain. This crystallization can occur even when the solvent is "good." Although the chemical potential in a good solvent does not encourage association, random thermal motions do allow the chains to briefly contact and occasionally overcome this "solvation force". At this point, if the conditions are correct, as is the case for PVA, the chains will start to crystallize. This rate of initial contact to initiate crystallization depends on the solvent quality. Therefore, as the solvent quality is decreased, the probability of the PVA chain associating increases since this is driven by the affinity of the chain for itself, which is described by the solvent quality. As a result, *rate* of change of solvent quality is important, as has been observed by manipulation of temperature. Since this process is related to the solvent quality, it depends on temperature, concentration and pressure. Therefore, the gelling of the PVA must depend on time, and more importantly, a competition between the association "time" and the phase separation "time". This competition has been observed experimentally, resulting in different initial gel structures depending on cooling rates and solvents, and in the aging of PVA gels.

Therefore controlling solvent quality by controlled solvent addition, or by temperature, pressure or any other relevant parameter allows one to control the *rate* of this association. Consequently, one desires to control the solvent quality of the system such that it is poor enough to accelerate the association rate by promoting the proximity of the chains while ensuring that the solvent is not so bad that the polymer falls out of solution before crystallization can occur. The optimal conditions for gel formation are likely to be in the range of $\chi = 0.25$ to 0.5 , but even outside these values it is possible to produce gels. By balancing these competing effects, a polymer/solvent solution can be obtained that is still fluid but gels rapidly.

For a single solvent with its solvent quality varied by temperature, or pressure, control, the spinodal decomposition phase transition is accelerated by the decrease in solvent quality. For a ternary blend, the phase separation can be understood as either the PVA is poorly solvated by the (continuous) water/solvent B blend and thus phase separates under the identical mechanism as the single solvent system; or both the PVA and solvent B are solvated by water, but have varying miscibility with each other. These materials therefore behave like a binary blend and, therefore, phase separate. Although conceptually slightly different, the results are almost identical. The behavior of two good solvents that result in a poor solvent is known as co-nonsolvency. This approach provides the ability to mix the components externally and then inject the PVA solution into a region of interest such as a cavity wherein it subsequently gels. This ability to inject PVA and induce gelation *in situ* is especially suitable for nucleus replacement or augmentation of intervertebral disks (IVD), since the second solvent can be anything that has the required thermodynamic properties. This second solvent can be a long chain polymer, protein or other complex molecule, or an aqueous solution thereof, such as polyethylene oxide (PEO), a glycosaminoglycan (GAG) or gelatin, or simpler molecules such as simply ionic species like salts, for example, NaCl or short chain molecules like poly(ethylene glycol), for example, PEG 400, glycerin or amino acids like serine or glycine. Although higher molecular weight species are not commonly characterized as solvents, the underlying theory, as described by Flory, makes no distinction as to the length of the solvent molecule, although the final interaction parameter for the solvent/polymer pair is affected by the solvent size.

PVA is known to associate at room temperature in deionized (DI) water over long times. This is well below the theta transition of PVA in pure water of 97°C. The crystallites generated in both the freeze-thaw process, and the thetagel process as used herein have a melt peak near 60°C. In addition, most studies involving PVA require elevated temperatures of at least 80°C to ensure that the PVA is fully “dissolved”. These observations suggest that above this temperature the PVA no longer possesses the ability to crystallize, and hence behaves like an ideal polymer with respect to solvent quality. Consequently, it is recognized herein that if one can dissolve the PVA in a solution above this critical melt temperature *there can be no*

crystallization, and hence no gelation, although there may be precipitation, or phase separation, due to simple association. If the solvent used is poor then there is some association through thermodynamic effects (and thus inhomogeneous precipitation may occur), but there can be no irreversible gelation that characterizes the PVA hydrogels. However, as soon as the temperature is lowered, crystallization can occur and the system can begin to gel. This gelation crystallization is still however rate limited, thus allowing the solution to be workable, even whilst below this temperature, and in a poor solvent. Mixing may influence this gelation rate by encouraging collision of the polymer chains.

10 In general, a physically cross-linked poly(vinyl alcohol) gel is prepared from an aqueous poly(vinyl alcohol) solution (from 1% to 50% PVA by weight of the solution) that is gelled by contacting with a solvent having a χ value sufficient for gelation, hereinafter called the second solvent at a concentration approximating the “theta” concentration for the poly(vinyl alcohol) solution.

15 The present invention provides methods of producing poly(vinyl alcohol) hydrogels that do not use chemical cross-linkers, irradiation or thermal cycling. In preferred embodiments, the solvent quality is controlled, preferably by controlling the diffusion of the second solvent (NaCl or methanol) into a PVA solution to produce a homogenous, physically crosslinked structure.

20 The present method uses a controlled change in solvents differing in solvent quality, conveniently expressed by the Flory interaction parameter to force the PVA to associate. Because no chemical cross-linkers are used, the gel is substantially free of chemical crosslinkers and thus likely to be as biocompatible as thermally-cycled PVA cryogels. Any residue of NaCl in the gel following equilibration in deionized water is likely to be benign, as its concentration will certainly be below physiologically relevant values.

30 Fig. 2 illustrates the relationship between the first solvent and the second solvent in terms of the Flory interaction parameter, χ . Fig. 2 is a graphical representation of the relationship of the Flory interaction parameter, χ , to the concentration (Φ) of a polymer at a given temperature. The abscissa, at $\chi = 0.25$, separates polymer solutions in first solvents (below) and polymer solutions in second

solvents (above) sufficient to cause gelation. The arrows and diamonds indicate the effect on χ produced by replacing solvent 1 with solvent 2.

By implication any solvent can be “good” or “bad” as defined using the Flory interaction parameter, χ . In terms of χ , these solvency properties are roughly $\chi < 0.5$ for good solvents and $\chi > 0.5$ for bad solvents, with the condition of $\chi = 0.5$ defining a “theta” solvent. The good-bad solvent transition is not a step change, but is instead a gradual variation in the solubility of the polymer in the chosen solvent. Consequently, changing the solvent quality changes the affinity of the polymer with itself, either through intra-chain interactions if the solution is sufficiently dilute, or through inter-chain interactions. The effects of changing solvent quality on polymer solubility can be seen in experimental data, or theoretically as shown in equation 1:

$$v = (1 - 2\chi)a^d \quad (1)$$

where v is excluded volume of a single chain, χ is the Flory interaction parameter and a^d is the monomer volume. The theta point, where the chain is unperturbed, is therefore where $v = 0$ or $\chi = 0.5$. For $v < 0$, phase separation occurs and there is an equilibrium between nearly pure solvent and a polymer-rich phase. However, due to the large size of the polymer molecules discussed herein, there is always some polymer in the solvent phase, and similarly there is always an appreciable amount of solvent in the polymer rich phase. The solvent can be a single chemical species, or a mixture of species that is not necessarily limited to low molecular weight compounds.

It is usually considered that PVA phase separates through a spinodal decomposition process. Note that there is no rate dependent effect in this equation, although the spinodal decomposition process does have a characteristic rate, and it is a balance of rate effects that is exploited in the embodiments of the present invention. For PVA in water, the Flory interaction parameter is weakly dependent on concentration but $\chi > 0.5$ for polymer volume fractions greater than about 5%. The PVA gel has a higher interaction parameter than the solvent but there is no dependence of χ on molecular weight or crosslink density of the gel.

In preferred embodiments, χ of the second solvent must be more positive than the χ of the first solvent (dissolved PVA solvent) and is preferably be in the range of 0.25 to 2.0. Preferably χ of the first solvent is in the range of 0.0 to 0.5. In general, the temperature during processing may vary from just above the freezing point of the

PVA solution to the melting point of the physical crosslinks formed in the process. The preferable range is from about 0 degrees Celsius to about 40 degrees Celsius. Note that χ is coupled to temperature and concentration. In preferred embodiments the temporal and spatial change in χ of the PVA solution (the first solvent) is
5 controlled by contact with another miscible solution (comprising the second solvent), wherein the second solvent modifies the first.

The removal of the need for chemical crosslinkers and radiation processing allows a greater variety of embedded components. For instance many bioactive materials are highly intolerant of chemical crosslinkers and radiation. In addition
10 although in general the freeze-thaw process is gentle on bioactive components there can certainly be envisaged polymers, biopolymers or cells that either cannot be frozen, or act as antifreeze hence preventing the freezing.

The method used to create these thetagels is likely to produce a wider range of material properties and greater control over the physical structure of the final gel than
15 is possible with competing cryogels. The advantage of thetagels over thermally cycled PVA gels for certain applications is outlined below.

Cryogels have a fairly low resolution with regard to their final properties because each thermal cycle produces a dramatic change in the material properties of the gel. The thetagels produced demonstrate that the concentration of the solvent
20 produces a monotonic decrease in swelling ratio once the theta value is passed (See Fig. 7). It is desirable that the ultimate crosslink density is adjustable in proportion to the resolution achievable in the solvent concentration. For example, for the 10% PVA solution immersed in NaCl, the weight percentage of PVA in the final gel varies at a rate of about 7%/mole NaCl.

The preferred embodiments of the present invention provide gels having a starting weight (based on the weight of the solution) from about 1 weight % to about 50 weight % PVA. In preferred embodiments, the weight percent ranges from about 12% to about 29% PVA in the final gel where the immersion solution used was about 2.0 about 3.0 M NaCl (aq). This range of final PVA weight percentages is
25 comparable to that which can be achieved by thermally cycled PVA. With higher NaCl solutions (in excess of 6.0 M) percent PVA of the final gel increases
30 monotonically with NaCl concentration. It has been found that PVA thetagels can be

made that exhibit a smooth gradient in spatial properties. In contrast, gradients of properties cannot easily be manufactured in cryogels. Instead, the usual approach is to generate an array of stacked lamellae independently that must be joined in dissolved PVA and then cycled again. Sharp differences in modulus in such an array would create a material with undesirable mechanical properties and with inhomogeneous interfaces. In preferred embodiments, PVA thetagels having a smooth gradient in mechanical properties, can be used to make a prosthetic intervertebral disk a central lower modulus "*pulposus*" having adequate compressive strength and a higher modulus peripheral "*annulus*" that minimizes creep and undesirable distortion.

Modulus enhancement can be accomplished by incorporation of ionic species. For thetagels produced in NaCl, it is possible to include natural (hyaluronic acid) or synthetic (PAA) polymers to create gels with strain variable compressive moduli. Gelling a PVA/PAA solution in strong NaCl shield the ionizable charges in the PAA while the PVA is crosslinked around the collapsed PAA. Re-equilibration in deionized water will allow expansion of the PAA and pre-stress the PVA matrix. The resulting construct should have a very different mechanical compressive modulus due to the repulsion of the fixed charges on the incorporated PAA.

It is known in the art that PVA elicits little or no host biological response when implanted in animals. For this reason, PVAs are used in a variety of biomedical applications including drug delivery, cell encapsulation, artificial tears, artificial vitreous humor, contact lenses, and more recently as nerve cuffs. However, PVA has generally not been considered for use as a load bearing biomaterial primarily because of its low modulus and poor wear characteristics. The loads that any vertebral implant must withstand will be reasonably high (on the order of 4 MPa in compression) requiring a high compressive modulus. In vivo, the compressive axial load on the intervertebral disk is transferred by the *nucleus pulposus* to a tensile circumferential load in the *annulus fibrosis*. Any biomaterial intended to replace the function of an intervertebral disk in its entirety must incorporate similar anisotropic properties.

To improve overall strength, PVA modulus and wear characteristics can be enhanced by the formation of either chemical or physical cross-links. Cross-linking

PVA by the addition of chemical agents (such as polyaldehydes), through irradiation, or by freeze-thaw cycling, has been shown to improve the durability of PVA gels. However, chemical additives can leave unwanted residual reactive species behind that make the final product unsuitable for transplant, while irradiation may adversely affect any bioactive material encapsulated in the matrix. Thus, the generation of extensive physical cross-links through freeze-thaw cycling has substantially improved the durability of PVA without the negative side effects produced by chemical or irradiation induced crosslinking. Recent investigations suggest that the physical crosslinks produced by freeze-thaw cycling might generate biomaterials with moduli suitable for use as biocompatible replacements for load bearing structures such as articular cartilage or intervertebral disk.

Solvation of polymers and the "theta" point:

Polymers in solution are complex molecules in perpetual dynamic motion. The configuration of an ideal polymer chain is usually described as a "random walk", where the molecule is assumed for simplicity to be freely jointed and free to move where it will. This behavior results in the polymer assuming a spherical shape with a Gaussian distribution. In reality the chain has a number of forces acting on it to define its shape and behavior. In free solution the chain is subject to random motion from Brownian fluctuations arising out of the temperature of the system. At the same time there is a force arising out of how the chain interacts with itself (since it is a long, extended molecule) and its surroundings.

If the polymer is easily solvated by the solution (i.e., it is in a first solvent not having a χ value sufficient for gelation) it swells as it tries to maximize the amount of polymer chain that is exposed to the solvent. In the first solvent, the energy of interaction between a polymer element and a solvent molecule adjacent to it exceeds the mean of the energies of interaction between the polymer-polymer and solvent-solvent pairs as described by Flory, P.J. in, Principles of Polymer Chemistry, page 424, Cornell University Press, 1953, the teaching of which are herein incorporated by reference in their entirety. The chain is now in a perturbed state and resists contact with neighboring chains and equally resists mechanical compression and deformation. As the solvency changes, this swollen configuration collapses as the quality of the solvent falls.

At the theta point, the solvent quality is such that the random Brownian motions are enough to keep the chain in an ideal, Gaussian distribution. Below this critical threshold the chain segments prefer to be next to each other rather than to a solvent molecule, and the chain shrinks (i.e. a second solvent having a χ value sufficient for gelation). The Flory interaction parameter, χ is dimensionless, and depends on temperature, pressure, etc. The first solvents have a low χ , while the second solvents have a high χ , with a transition at about $\chi = 0.5$. The case $\chi = 0$ corresponds to a solvent which is very similar to a monomer. In a lattice model this is the case where the free energy comes entirely from the entropy associated with various chain patterns on the lattice. In such a case, temperature has no effect on structure, and the solvent is said to be "athermal." Athermal solvents are a particularly simple example of good solvents. In most cases the parameter χ is positive as described by de Gennes, P.G. in, *Scaling Concepts in Polymer Physics*, First ed. p. 72: Cornell University Press (1979). If the solvent quality is poor enough, the chain will completely precipitate out of solution. This effect can also be obtained by manipulation of the temperature of the solution.

Once the concentration of the polymer solution is high enough, adjustment of the solvent quality can be achieved by replacing at least part of a first solvent with a second solvent that forces inter-chain interaction as well as intra-chain interaction. Once the physical crosslinking has occurred, the later presence of a good solvent, which naturally swells the free polymer, is balanced by the physical crosslinking. With inter-chain associations the polymer chains are now constrained at certain pinning-points. Consequently as the polymer is solvated, and stretches, it becomes more deformed and is forced into tension. It is the competition between the solvation of the polymer chains and this tension in the deformed chains that give gels their interesting mechanical behaviors. In addition, under certain conditions the polymer chains can be ionized, consequently generating a charge. Adjacent like charges will result in further swelling due to electrostatic repulsion. This is part of the mechanism that gives natural cartilage (collagen and glycosaminoglycans) its high modulus, and high hygroscopic properties.

Gelation mechanism in PVA:

Freeze-thaw cycling of solutions of PVA polymer results in the formation of physical cross-links (i.e. weak bonding through an "association" of the polymer chains). PVA hydrogels formed in this manner are termed "cryogels" and are described, for example, in U.S. Patent No's. 6,231,605 and 6,268,405, the teachings of which are incorporated herein by reference in their entirety. Importantly, the techniques utilized to create PVA cryogels do not require the introduction of chemical crosslinking agents or radiation. Cryogels are therefore easily produced with low impact on incorporated bioactive molecules. However, incorporated molecules are limited to those that can tolerate the freeze-thaw cycles required to make the gel. Thus the resulting material can contain bioactive components that will function separately following implantation. PVA cryogels are also highly biocompatible (as will be the proposed PVA "thetagels" to be presented later). They exhibit very low toxicity (at least partially due to their low surface energy), contain few impurities and their water content can be made commensurate to tissue at 80 to 90 wt%.

There is still some debate over the exact mechanism that drives the gelation of PVA through a freeze-thaw cycle. However, three models have been proposed to explain the physical crosslinking that occurs during the freeze-thaw cycle: 1) direct hydrogen bonding; 2) direct crystallite formation; and 3) liquid-liquid phase separation followed by a gelation mechanism. The first two steps suggest that the gel forms through a nucleation and growth (NG) phase separation, whereas the third option pictures the process as a spinodal decomposition (SD) phase separation. Hydrogen bonding will form nodes and crystallite formation will form larger polymer crystals. However both of these mechanisms will form closely connected crosslinks, with relatively small crosslinking nodes. This observation is supported by studies on the gelation mechanism of PVA. Spinodal decomposition on the other hand causes redistribution of the polymer into polymer rich and polymer poor regions followed by a gelation process which results in more distantly spaced crosslinks. It is thought that phase separation through spinodal decomposition is likely to be responsible for the improved mechanical properties of PVA after crosslinking and occurs due to a quenching of the polymer solution. During the freezing process, the system undergoes a spinodal decomposition whereby polymer rich and poor phases appear

spontaneously in the homogeneous solution. This process occurs because the phase diagram of quenched PVA (and polymers in general) at certain temperatures can have two coexisting concentration phases. The polymer rich phases are therefore highly concentrated which enhances the natural (weak) gelation of the PVA.

5 For cryogels, the physical characteristics depend on the molecular weight of the uncrosslinked polymer, the concentration of the aqueous solution, temperature and time of freezing and the number of freeze-thaw cycles. Thus the properties of a cryogel can be modulated. However, since the material's properties change dramatically at every freeze-thaw step, control over the properties of the finished gel is somewhat limited. The thetagels described broaden the range of functionality
10 currently provided by PVA cryogels.

In general, the modulus of the PVA cryogel increases with the number of freeze-thaw cycles. In one experimental series, thermally cycled PVA cryogels had compressive moduli in the range of 1-18 MPa and shear moduli in the range of 0.1-
15 0.4 MPa. Stammen, J.A., et al., Mechanical properties of a novel PVA hydrogel in shear and unconfined compression *Biomaterials*, 2001 22: p. 799-806.

As cryogels are crosslinked by physical and not chemical means, there is some concern about their structural stability. The modulus of PVA in aqueous solution increases with soak time in distilled water at constant temperature. In one
20 experiment, conducted over 40 days, the modulus increased by 50%. Putatively, during aqueous aging, the increase in strength, with the concomitant loss of soluble PVA, is the result of an increase in the order of the supramolecular packing of the polymer chains. There are significant implications in this data for the long-term storage effects of the freeze-thaw gelled PVA.

25 It is also important to understand the effects of loss of polymer over time and how that impacts the local host biological environment. It should be noted that in this example, the cryogel was only freeze-thaw cycled once, although others have shown PVA dissolution following multiple freeze-thaw cycles. In general, there is very little information about the stability of PVA cryogel modulus under repeated load cycling
30 (fatigue).

As might be expected, the swelling of PVA cryogels at any time point decreases with increasing number of freeze-thaw cycles, indicating a densification of

the PVA gel, most likely due to a higher crosslink density. In the long term, following gelation and under static conditions, the ultimate swelling ratio decreases while the modulus increases with time.

In freeze-thaw processing, temperature is used to force a phase separation of the PVA solution, thus enhancing the gelation mechanism in the PVA (it should be noted that even at room temperature a solution of PVA begins to gel weakly over time).

Solvent quality is related to both temperature and the chemical interaction of the solvent to the polymer, and is conveniently described by the Flory interaction parameter χ . In a preferred embodiment, the manipulation of the solvent quality through some process other than temperature allows much greater control over the gelation process while permitting the method to be practiced at approximately room temperature. In particular, by using aqueous based solvents for PVA, the system can be chosen to minimize impact on materials embedded in the PVA, and can allow fine spatial and temporal control over the final structure of the gel. In a particular solvent, the critical parameter defining the transition from the first to second solvent (and hence driving the phase separation) is known as the theta temperature. An example list is presented in Table 1 below.

Table 1:
Theta temperatures for PVA in various solvents
(Brandrup, J. & Immergut, E.H., Polymer Handbook, 3Ed. 1989, NY, John Wiley & Sons).

Solvent	Volume Ratio	Theta Temperature [°C]
t-Butanol/Water	32:68	25
Ethanol/Water	41.5:58.5	25
Methanol/Water	41.7:58.5	25
i-Propanol/Water	39.4:60.6	25
n-Propanol/Water	35.1:64.9	25
NaCl/Water	2 Moles/L	25
Water	-	97

Physically cross-linked PVA gels may also be produced through thermal cycling (not necessarily with freezing) combined with dehydration. Such gels are potentially suitable for use in load bearing applications (i.e. artificial articular cartilage). Examination of the material properties of this thermally cycled PVA found that the material distributes stress more homogeneously than stiff single-phase biomaterials (ultrahigh molecular weight polyethylene (UHMWPE)) and preserves

the lubrication film gap readily in simulated articular cartilage loading. The material sustained and distributed pressure in the thin film of between 1 and 1.5 MPa. In transient load tests, the PVA withstood and distributed loads of nearly 5 MPa.

Studies have been conducted that further examined the wear properties of their thermally cycled, dehydrated PVA under a variety of conditions. The wear rate found in unidirectional pin-on-disk (against alumina) experiments was comparable to that of UHMWPE (although this test is probably not the most suitable to perform for biological implants). However, in reciprocating tests, the wear rate was up to 18 times larger. To improve the wear properties, PVA of higher molecular weight and additionally cross-linked by gamma-radiation (doses over 50 kGy) was tested. Such treatment reduced the wear rate considerably (to about 7 times that of UHMWPE). However, in both radiation and thermally crosslinked PVA the wear rate does not appear adequate for applications where the opposing surface has high hardness. Additionally, irradiation would adversely affect bioactive materials loaded into the gel.

Methods in accordance with a preferred embodiment include the following:

PVA solutions. To make the 10% solution, 20 grams of PVA (100 kg/mole; 99.3+% hydrolyzed; JT Baker) was dissolved in 180 grams of deionized water at 90°C for one to two hours. To make the 20% solution, 30 grams of PVA was dissolved in 180 grams of deionized water, the solution was stirred continuously until 60 grams of water evaporated to generate a final solution of 20% PVA.

PVA gelation. 4-5 ml of PVA solution of 10 or 20 weight percent were injected into pre-wetted Slide-A-Lyzer Dialysis cassettes (Pierce, Rockford, IL) with a molecular weight cutoff of 3500 Daltons. The 10% PVA solutions were then immersed in NaCl aqueous solutions of 1.5 M, 2.0 M, 2.5 M or 3 M. The 20% PVA solution was immersed in 3.0M NaCl. To demonstrate that the gelation effect was not NaCl/aqueous solvent-dependent, a 10% PVA solution in a dialyzer cassette was immersed in a 50/50 methanol/water solution. After 3 days, all of the cassettes containing 10% PVA solution were removed from their respective solvents. The gels were then removed from the cassettes and placed in DI water for at least 5 days to allow initial PVA crystal dissolution the cassette containing the 20% PVA solution was removed after 3 days. The PVA gel was removed from the cassette and a portion

was stored in DI water. The remaining PVA gel was returned to the 3M NaCl solution. At 6 and 12 days, portions of the 20% PVA gel were removed and placed into DI water for at least five days before further testing.

Quantitative Characterization:

5 To quantify the effect on the structure of the gels of immersion solution molarity and time immersed, differential scanning calorimetry (DSC), gravimetric swell ratio analysis and dynamic mechanical analysis (DMA) were performed on the samples.

Differential Scanning Calorimetry. DSC thermograms were obtained using
10 an instrument, for example, a TA Instruments Q1000 (TA Instruments, New Castle, DE). Selected wet PVA gel samples between 5 and 15 mg were removed from deionized water storage after 5 days, blotted dry and crimped into alodized-aluminum hermetic pans. Scans were performed at 5°C/min from 5°C to 120°C. The total enthalpy change for the melting of the gel physical crosslinks was estimated using a
15 linear integration from the departure from baseline (typically near 40°C) to return to baseline (typically near 90°C). Following DSC analysis, the hermetic pans were punctured, weighed and placed in a vacuum oven for dehydration. After two days of dehydration the pans were reweighed to determine the percent PVA in the original sample.

20 *Gravimetric swell ratio.* Samples of PVA gel from each sample were removed from deionized water storage after 5 days, blotted with a tissue and dehydrated in a vacuum oven for 2 days. The gravimetric swell ratio was calculated as the ratio of the mass of water in the gel to the mass of PVA in the gel.

Dynamic Mechanical Analysis. To examine the effect of curing solvent
25 quality, dynamic mechanical analysis was performed using a Perkin-Elmer TMA 7 (Perkin Elmer, NJ) on the 10% PVA 3 M NaCl and 2 M NaCl samples. To examine the effect of aging in the curing solvent, DMA was also performed on the 20% 3 M NaCl 3 day and 12 day samples. Samples were cut into rectangles and tested in unconfined compression with a static load of 250 mN (10% samples) or 1000 mN
30 (20% samples). The storage (and loss moduli for the 10% samples) were determined for a frequency sweep from 1 to 2 Hz at room temperature.

In a preferred embodiment, forcing poly(vinyl alcohol) polymer chains in solution into close proximity (through a spinodal decomposition mechanism) results in the formation of a physical association that is resistant to dissolution. This methodology generates a PVA hydrogel employs the controlled use of the second
5 solvents having a χ value sufficient to cause gelation to force the PVA chains to physically associate. It is critical that the solvent quality is controlled carefully, and in particular for larger components, that the solvent "front" enters the PVA solution in a controlled manner. NaCl/deionized water and methanol/deionized water solutions at concentrations in the neighborhood of their "theta" value for PVA were
10 used to force the physical association and subsequent gelling of the PVA. Gels formed in this way are termed "thetagels".

The physical appearance of the hydrogel depends on the molarity of the solution into which the PVA solution is immersed. Fig. 3 demonstrates the progression of the gelation of the PVA hydrogel during exposure to NaCl solutions
15 near the "theta" concentration. As exposure time increases, the PVA solution becomes stiff and opaque for the solutions at or above the theta concentration and temperature. For solutions appreciably below the theta concentration, little or no gelling is apparent. Immersion of the PVA solution into the 50/50 water/methanol solution also resulted in the generation of a uniform PVA hydrogel.

20 Fig. 3 shows 10% PVA solution in dialyzer cassettes after 1 day (top) and 3 days (bottom) of immersion in curing solution. From left to right: 1.5 M NaCl, 2.0 M NaCl and 3.0 M NaCl. The 1.5 M solution does not gel the PVA, but the 2.0 M solution and 3.0 M solution do gel the PVA. Note the progressive opacification of the 2.0 M gel and the shrinkage of the 3 M gel from the edges of the cassette as the
25 sample compacts with time (indicated with arrow).

Fig. 4 demonstrates the difference between 10% PVA exposed to 3.0 M and 2.0 M solutions for 3 days (after photographed subsequent equilibration in deionized water). PVA gels were generated by immersion in 3.0 M (left image of each pair) and 2.0 M (right image) NaCl immersion solution. Note that the gels are uniform and
30 opaque. The gel exposed to 3.0 M NaCl swells less and is more compact following equilibration in deionized water. The hydrogels that result are uniform and opaque. The PVA exposed to 2.0 M NaCl is more highly hydrated than that exposed to the 3.0

M NaCl. The increased swelling is an indication that the density of physical crosslinks is lower in the gel exposed to the 2 M NaCl solution. Thus, gels formed in this way are “tunable” with respect to mechanical properties. Further, gradient gels can be made using the method through manipulation of the spatial NaCl concentration.

Fig. 5 shows a hydrogel formed from a 10% PVA solution that was exposed to a spatially varying NaCl concentration. Note, the variation in both the translucency of the gel and in the swelling ratio. The opaque part of the gel was exposed to 3.0 M NaCl while the clear part was exposed to a concentration below the theta concentration (2.0 M at room temperature). The ability to generate a gradient is relevant to the generation of a total disk replacement nucleoplasty, with a rigid outer layer (*annulus fibrosis*) and a softer center (*nucleus pulposus*).

Differential Scanning Calorimetry:

For thermally cycled PVA gels, an endotherm between 30 degrees Celsius and 90 degrees Celsius represents the energy required to disrupt the physical crosslinks formed during the thermal processing. For PVA thetagels in accordance with a preferred embodiment, a similar endotherm was present. Fig. 6 compares the DSC thermogram of a thermally cycled PVA cryogel and a PVA hydrogel formed in 3.0M NaCl. The transitions have similar melting endotherms and occur at virtually the same temperature.

The enthalpy change of this endothermic transition gives a good indication of the amount of crosslinking in the gel as a result of the solution conditions. For a 10% PVA solution for example the enthalpy change obtained after immersion for 3 days in a 2.0M solution of NaCl was 16.9 J/g. In contrast the same initial PVA solution yielded an enthalpy change of 19.9 J/g after 3 days in a 3M solution. This result indicates that solution concentration and soak time both positively impact the amount of physical crosslinking in the gel.

Gravimetric Swell Ratio:

In a preferred embodiment, increasing the molarity of NaCl in the solvent increases the amount of PVA present in the hydrogel per unit mass. Fig. 7 shows the relationship between the percentage of PVA in the gels (fully equilibrated in deionized water) and the molarity of the solution in which they were cured. Because

the PVA is not rigidly held in the dialysis cassette, it is free to expand or contract under the influence of the local forces on the PVA during the gelation process. It is therefore possible for the final PVA concentration to exceed that of the initial PVA solution if the PVA gel has collapsed. Fig. 8 shows the gravimetric swelling ratio for PVA cured in solutions of varying NaCl molarity. For the 20% PVA solution, the 3 day value of swelling ratio and percentage of PVA matched that of the 10% PVA solution (not shown). After 12 days of immersion in 3 M NaCl (and 5 days of equilibration in deionized water), the 20% PVA solution formed a gel that was 29% PVA.

10

Dynamic Mechanical Analysis:

In a preferred embodiment, the solution conditions and time of aging have a marked effect on the visible structure of the gels, and on their thermal properties. Both effects suggest that there is likely to be an influence on the mechanical properties as well. This supposition is born out by qualitative examination of the samples, but for more rigorous analysis mechanical testing was performed on the samples using DMA. Figs. 9 and 10 present data taken from three of the samples. Fig. 9 shows that the complex modulus of the sample increases with aging (keeping all other solution conditions constant). In fact, this increase in the modulus is also paralleled by a densification of the final PVA gel. Fig. 10 examines the change in modulus corresponding to the change in solution molarity (once again keeping all other parameters constant). In this Fig.10, there is a clear indication that the storage (i.e., elastic component) modulus rises sharply as the solution molarity is increased (remember at room temperature 2 M NaCl is approximately a theta solvent) whereas the loss (i.e., damping) modulus is barely affected.

25

Cryogels have a fairly low resolution with regard to their final properties because each thermal cycle produces a dramatic change in the material properties of the gel. The thetagels produced demonstrate that the concentration of the solvent produces a monotonic decrease in swelling ratio once the "theta" value is passed (See Fig. 7). Thus, the ultimate crosslink density can be fine tuned in proportion to the resolution achievable in the solvent concentration. For example, for the 10% PVA solution immersed in NaCl, the weight percentage of PVA in the final gel varies at a rate of about 7% per mole NaCl.

30

In preferred embodiments, the PVA thetagels can be made that exhibit a smooth gradient in spatial properties. Gradient properties cannot easily be manufactured in cryogels. Instead, the usual approach is to generate an array of stacked lamellae independently that must be joined in dissolved PVA and then cycled again. Sharp differences in modulus in such an array create a material with undesirable mechanical properties and with inhomogeneous interfaces. A preferred embodiment includes a composite *annulus fibrosus/nucleus pulposus* implant, that benefit from technology enabling a smooth gradient in mechanical properties, wherein a central lower modulus “*pulposus*” provides adequate compressive strength and a higher modulus peripheral “*annulus*” minimizes creep and undesirable distortion.

Modulus enhancement: Incorporation of ionic species:

For thetagels produced in NaCl, it is possible to include natural (hyaluronic acid) or synthetic (PAA) polymers to create gels with strain variable compressive moduli. Gelling a PVA/PAA solution in strong NaCl will shield the ionizable charges in the PAA while the PVA is crosslinked around the collapsed PAA. Re-equilibration in deionized water will allow expansion of the PAA and pre-stress the PVA matrix. The resulting construct has a very different mechanical compressive modulus due to the repulsion of the fixed charges on the incorporated PAA.

Generating gradient thetagel:

In another preferred embodiment, to make the gradient thetagel: 10%, 20% and 30% solutions of 100kg/mole PVA are made as described hereinbefore. A dialyzer cassette is split in half and each half bonded to one side of a 1x1x1 cm plexiglass box that is filled with the 10% PVA solution. The sealed box is placed into a temperature controlled “Ussing” style chamber where it is subjected to a constant 4 molar NaCl concentration difference (see Fig. 10). After the number of days where further changes in the gel are insignificant, the gradient gel is removed from the chamber and placed in deionized water for five days prior to further testing. Resulting gels are tested as described hereinbefore.

In another embodiment, spatial gradient can be generated using temporal oscillations in concentration. The concentration in the chamber can be modulated

temporally to provide a gel, having a softer interior region than the peripheral region where a higher crosslinking occurs.

The chamber 100 includes a cartridge 140 containing a gel 160. The chamber can be divided into sub-chambers or regions including two immersion solvents 112 and 122. In a preferred embodiment, the solvents have the same concentration. In
5 another preferred embodiment, the immersion solvents have different concentrations that cause a spatial gradient in the gel. Membranes 150, 154 are permeable membranes that allow the immersion solvents to selectively flow into the vinyl polymer solution. Membrane 130 provides an impermeable barrier to the flow of any
10 solvent.

Dehydration:

Preferred embodiments of the present invention are directed at controllably structuring gels. In a particular embodiment, in order to promote smooth dehydration and to homogenize the physical crosslinking of the PVA thetagel, the gel or solution
15 of PVA may be immersed in a series of solutions, or in a bath of smoothly changing solvent quality, each with a higher Flory interaction parameter than the previous solution. This prevents the local "crashing out" of PVA at the surface directly in contact with the immersion solution. The term "crashing out" as used herein is associated with a phenomenon akin to precipitation because of the Flory interaction
20 parameter. The polymer chains prefer to associate with themselves instead of the solvent as the Flory interaction parameter is above the theta point and thus precipitate or crash out.

In one preferred embodiment, a thetagel may be created by first immersing the contained PVA solution into a solvent which has a Flory interaction parameter that is
25 higher than the theta point for the PVA solvent pair. After a period of time the contained PVA is immersed in another solvent, which has a Flory interaction parameter lower than the theta point for the PVA solvent pair. The process can continue with immersion of the contained PVA in solutions having successive decreases in the Flory interaction parameter until the desired interaction parameter
30 value for the final gel is reached.

A method to form a thetagel in accordance with a preferred embodiment of the present invention includes immersing contained 5-20% PVA in DI, followed by

immersion for a range of 1 hour to 1 day in 2.0 M NaCl, followed by immersion for a time period ranging between 1 hour to 1 day in 3.0 M NaCl, followed by immersion for a time period of 1 hour to 1 day in 4.0 M NaCl, and followed by immersion for a time period ranging from 1 hour to 1 day in 5.0 M NaCl.

5 In another preferred embodiment, the PVA solution may be subjected to a gradually changing solvent quality through a similar range of electrolyte concentrations by the gradual addition of a concentrated NaCl solution to a DI water bath such that the change of the salt concentration is slower, or equal to, the diffusion process into the gel.

10 A method in accordance with a preferred embodiment includes immersing contained 5-20% PVA in 1 liter of 1.5 M NaCl, and adding 6 M NaCl at a rate of 0.5 ml per minute to raise the electrolyte concentration at a rate of 0.0038 M/min and reaching 5 M NaCl after approximately 12 hours.

In another embodiment, the PVA solution may be subjected to one or many
15 freeze-thaw cycles to fix the gel into a particular shape. It may then be immersed in a series of solutions having successively higher Flory interaction parameters until the final desired Flory parameter is reached.

A method in accordance with a preferred embodiment includes dissolving 5-
20 20% PVA in DI, subjecting the solution to freeze-thaw cycles (approximately 1-8 cycles), and subsequently for a period ranging between 1 hour to 1 day, immersing the resultant gel in 2.0 M NaCl. The method further includes immersing the PVA gel for a time period of 1 hour to 1 day in 3.0 M NaCl, followed by immersion for a time period ranging from 1 hour to 1 day in 4.0 M NaCl and subsequently immersing for a time period of 1 hour to 1 day in 5.0 M NaCl.

25 In an alternate preferred embodiment, a method to form a gel includes dissolving a 5-20% PVA in DI, adding NaCl to the PVA solution to generate a concentration from 0.01 to 2 M NaCl in the PVA solution and then subjecting the PVA/NaCl solution to between 1 to 8 freeze-thaw cycles.

Nanostructuring:

30 Polyvinyl alcohol gel is an extremely biocompatible material that can be made reasonably stiff without the use of chemical crosslinking or irradiation. However, the material properties of the PVA do not match the requirements of materials for use in

load bearing applications such as, for example, artificial articular cartilage or intervertebral disks. A nanostructural enhancement of polymer systems in accordance with a preferred embodiment of the present invention indicates that PVA gels, which are already nearly suitable for use in load bearing orthopedic devices, 5 may become viable candidates for such applications.

Nanostructuring polyvinyl alcohol theta and hydrogels - particles. The addition of particles to polymeric materials can improve the mechanical and thermal properties of the resulting material when compared to formulations of the neat polymer. Recently, it has been shown that the addition of nanoparticles to polymers 10 can generate similar enhancements in the material properties, but with much lower particulate concentrations than those required of micron sized particles. This is particularly true when the material properties are dependent on surface area. In accordance with preferred embodiments, to strengthen polyvinyl alcohol thetagels or hydrogels, the dispersion of uncharged nanoscale particles or charged nanoscale 15 particles with uniform or spatially varying surface charges into the solution prior to gelation enhances the mechanical and thermal properties of the final gel. Nanoscale particles, if dispersed properly, provide regular nucleation sites for physical crosslinking by adsorbing PVA chains to their surfaces in accordance with a preferred embodiment of the present invention. As in rubber toughened plastics, these 20 nanoparticles also act as stress concentrators, thus toughening the gel. Nanoscale particles that may enhance the properties of PVA gels are, for example, clays (for example, but not limited to, Laponite, montmorillonite), fumed silica, titanium dioxide or hydroxyapatite. Surface treatments and modifications, such as end grafting of polymers also adjust the way in which the particles interact with the 25 polymer gel matrix in accordance with a preferred embodiment of the present invention. These particles may also be biologically active, such as, for example, capable of releasing drugs to promote growth, or reduce inflammation. Nanostructuring is not limited to thetagels in accordance with a preferred embodiment of the present invention. However, the thetagels in accordance with the 30 present invention allow the formation of physical crosslinks around charged particles under solution conditions where the Debye length is reduced compared to the working solution. Thus when the gel is replaced in the working solution of lower

electrolyte concentration the particles interact through electrostatic forces and add compressive strength to PVA thetagels as compared to PVA freeze-thaw gels.

In one embodiment, nanoparticles are dispersed into solutions of PVA. The solvent may be water, DMSO, methanol or any other solution that exhibits a Flory interaction parameter that is lower than the theta point for the PVA solvent pair
5 during solution preparation. The PVA/nanoparticle mixture is then subjected to at least one freeze-thaw cycle. Subsequent to the freeze-thaw cycling, the gelled PVA is immersed in a solvent that has a Flory interaction parameter near or higher than the theta point for the PVA/solvent pair to induce further physical crosslinking of the
10 PVA/nanoparticle mixture.

A method in accordance with a preferred embodiment of the present invention includes mixing 5-20% PVA in DI with 1-10% fumed silica, freeze-thawing (1-8 cycles) the solution, followed by immersion for a time period ranging from 1 hour to 5 days in 2-5 M NaCl.

15 In another embodiment, the PVA/nanoparticle mixture is gelled by immersion into a solvent that has a Flory interaction parameter near or higher than the theta point for the PVA/solvent pair to induce physical crosslinking of the PVA/nanoparticle mixture. No freeze-thaw cycling is necessary in this embodiment.

A method in accordance with a preferred embodiment of the present invention
20 includes mixing 5-20% PVA in DI with 1-10% fumed silica, followed by immersion for a time period ranging from 1 hour to 5 days in 2-5 M NaCl.

In another embodiment, the composite gels resulting from the two examples described hereinbefore are subject to further freeze-thaw cycles.

In another embodiment, PVA solutions or gels containing nanoparticles are
25 subject to the dehydration protocol as described hereinbefore. A method in accordance with a preferred embodiment of the present invention includes mixing 5-20% PVA in DI with 1-10% fumed silica, subjecting the solution for 1-8 cycles of freeze-thawing, followed by immersion for a time period ranging from 1 hour to 1 day in 2.0 M NaCl, followed by immersion for a time period ranging from 1 hour to 1
30 day in 3.0 M NaCl, followed by immersion for a time period ranging from 1 hour to 1 day in 4.0 M NaCl and subsequently followed by immersion for a time period ranging from 1 hour to 1 day in 5.0 M NaCl.

Nanostructuring polyvinyl alcohol thetagels and cryogels – functionalized molecular additives. The addition of particles to the PVA solution prior to gelation can provide enhancement of the thermal and mechanical properties of the gel.

However, there is a class of molecular additives that can be functionalized to promote physical crosslinking and can simultaneously act as stress concentrators. Polyhedral oligomeric silsesquioxane (POSS) can enhance mechanical properties of polymeric materials. Since the POSS molecules can be functionalized, they can be tuned to associate with the PVA chains to enhance interchain crosslinking and to act as stress concentrators. Their extremely small size and large number of functionalized groups has the potential to provide better results than nanoparticle seeding.

All of the methods for generating thetagels or cryogels described hereinbefore may be applied to solutions containing dispersed functionalized POSS molecules. In one preferred embodiment, POSS functionalized to display negatively charged oxygen groups can be used to promote hydrogen bonding. The functionalized POSS is dispersed into aqueous PVA solution and subjected to theta or freeze-thaw gelation (ranges 0.01 mM to 1 M OctaTMA POSS (tetramethyl ammonium salt) and 5-20% PVA in solution).

In another preferred embodiment, POSS functionalized to display alcohol groups is dispersed into PVA and subjected to theta or freeze-thaw gelation (ranges 0.01 mM to 1 M Octahydroxypropyldimethylsilyl POSS and 5-20% PVA in solution)

In another embodiment, POSS functionalized to display at least one PVA chain and at least one carboxyl or sulfate group can be used to produce an extremely hydrophilic, tough artificial cartilage. The preferred POSS construct has at least one PVA chain at opposite corners of the POSS with the 6 remaining functional groups expressing sulfate or carboxyl groups. This structure can be “stitched” into the PVA gel network via the thetagel process or freeze-thawing to produce an artificial cartilage with tunable properties.

Fig. 12 illustrates a quick freeze deep etch (QFDE) image of PVA gel structure in accordance with a preferred embodiment of the present invention wherein the PVA gel is formed by immersion in 5 M NaCl for 3 days. The bar represents 100 nm. QFDE preserves the gel structure in its hydrated state.

Figs. 13A and 13B are a cross-sectional and a close-up view of the cross-section of a PVA gradient hydrogel, respectively, prepared by filling Plexiglass tubing with 10% PVA solution, performing one freeze thaw cycle (8 hours at -21°C ; 4 hours at room temperature) then immersing in 3 M NaCl bath for at least 3 days, and subsequently dehydrating in air for 60 hours and returning to deionized (DI) water in accordance with a preferred embodiment of the present invention. Figs. 13A and 13B illustrate the presence of radial gradients in PVA induced by air dehydration.

Fig. 14 illustrates a cross-sectional view of a PVA gradient hydrogel prepared by filling dialysis cartridge with 10% PVA solution, then immersing in a chamber having 3 M NaCl on one side and 6 M NaCl on the other side for 3 days in accordance with a preferred embodiment of the present invention. Fig. 15 illustrates a close-up view of the cross-section of the PVA gradient hydrogel of Fig. 14 on the 6 M NaCl side prepared by filling the dialysis cartridge with 10% PVA solution, and then immersing in a chamber with 3 M NaCl on one side and 6 M NaCl on the other for 3 days. Figs. 14 and 15 illustrate the presence of linear gradients in PVA induced by static NaCl solution gradient.

Figs. 16-19 illustrate nanostructured PVA gels in accordance with preferred embodiments of the present invention. More particularly, Fig. 16 illustrates a nanostructured PVA hydrogel prepared by mixing a solution of 10% PVA and 2 weight percent Laponite clay, subjecting to a 1 freeze-thaw cycle, then exposing the solution to a 4 M NaCl solution for at least 3 days in accordance with a preferred embodiment of the present invention.

Fig. 17 illustrates a nanostructured PVA hydrogel prepared by mixing a solution of 10% PVA and 4 weight percent of silica, titrating to $\text{pH} = 3$, subjecting to a 1 freeze-thaw cycle, then exposing to a 4 M NaCl solution for at least 3 days in accordance with a preferred embodiment of the present invention.

Fig. 18 illustrates a nanostructured PVA hydrogel prepared by mixing a solution of 10% PVA and 4 weight percent silica, titrating to $\text{pH} = 10$, subjecting to 1 freeze-thaw cycle, then exposing to 4 M NaCl solution for at least 3 days in accordance with a preferred embodiment of the present invention.

Fig. 19 illustrates a nanostructured PVA hydrogel prepared by mixing a solution of 10% PVA and 0.001 M octaTMA POSS in water, then subjecting to 1

freeze-thaw cycle in accordance with a preferred embodiment of the present invention.

Fig. 20 graphically illustrates storage moduli for hybrid and control PVA gels in accordance with preferred embodiments of the present invention. The graphs are results of DMA testing on 4% silica/PVA nanostructured gel having a pH=10 (sample number 1), 4% silica/PVA nanostructured gel having a pH=3 (sample number 2), 2% Laponite/PVA nanostructured gel (sample number 3), 0.001 M, 10% PVA + octaTMA POSS (sample number 4), and a control gel (sample number 5). All gels were subjected to 1 freeze-thaw cycle and then immersed in 3 M NaCl for three days. Prior to DMA testing the samples were equilibrated in DI water for at least 24 hours.

The embodiments of the present invention provide methods for the controlled manipulation of the Flory interaction parameter in a solution of vinyl polymer, in particular polyvinyl alcohol, to yield a workable fluid that gels in a controlled manner. The control of the solvent condition allows control of the gelation rate, which results in a time period in which the PVA solution has only partially gelled, thus permitting manipulation or working of the pre-cursor gel prior to final gelation. During this time period the PVA solution is substantially fluid and can be injected, pumped, molded, or undergo any other manipulative processing step. The final properties of the hydrogel, which include, but are not limited to, percentage crystallinity, crystal size, free volume, and mechanical properties, are influenced by the initial vinyl polymer concentration, the gellant concentration (*i.e.*, the final solvent quality) in the final mixture, the processing temperature, and the mixing procedure.

One preferred embodiment of the method is shown in Fig. 21A. Fig. 21A illustrates a flow chart of a method 400 of forming a PVA hydrogel including the step 402 of mixing a vinyl polymer and a first solvent; mixing a gellant in the vinyl polymer solution per step 404; and preventing gelation of the vinyl polymer physical associations by heating the mixture to a temperature above the melting point of the vinyl polymer per step 406. More particularly, this temperature is above the melting point of any physical associations formed in the vinyl polymer. In an alternate embodiment, step 406 precedes step 404. The method 400 further includes the step 408 of inducing gelation of the vinyl polymer solution; forming a transiently

workable viscoelastic solution per step 410; controlling or modulating the gelation rate of the viscoelastic solution per step 412, for example, by modulating at least one of the temperature, the pressure and the concentration gradient; and forming the hydrogel per step 414 in accordance with a preferred embodiment of the present invention.

Fig. 21B illustrates a flow chart of methods of forming and providing a vinyl polymer hydrogel in accordance with preferred embodiments of the present invention. These methods are directed at manufacturing vinyl polymer based hydrogels by modulating solvent quality. The methods include the step 424 of dissolving vinyl polymer in water at, for example, greater than 80°C at any desired concentration. The next step includes the preparation of a gellant as a powder per step 426, or as a solution per step 430. The gellant can naturally be a liquid per step 428. The next step 432 includes providing a gellant in sufficient concentration to be near (above or below) the critical theta condition of a subsequent mixture when added to the vinyl polymer solution. The method then includes the step 434 wherein the gellant and vinyl solution are kept separately, the step 436 of loading the components into a two or more chambered device such as a syringe or a pump, and the step 438 of injecting the polymer solution into a region of interest, such as a cavity in the body through a mixing apparatus. The solution arrives in the region of interest substantially mixed per step 410.

The method 400 after step 432 can alternatively include the step 442 of adding the gellant while mixing the vinyl solution, the step 444 wherein the solution is mixed until it is homogenous and step 446 wherein the vinyl polymer solution is still in a fluid and workable state. The method 400 can include the step 448 of loading the polymer solution into a syringe or pump followed by step 450 of injecting the solution into the region of interest in the body before the solution has substantially crystallized. In the alternative, after step 446, the method 400 can include the step 452 of placing the polymer solution in a mold shaped for a specific use or the step 454 of blow molding the polymer solution to form a thin hydrogel membrane or per step 456 of loading the polymer solution into a syringe or pump. Step 458 follows by injecting the solution into the region of interest and per step 460 triggering the gellant to drop solvent quality. Step 462 can follow the processing steps 440, 450, 452, 454

or 460 alternatively and includes the permanent crystallization of the gellant that occurs substantially after the above listed processing steps.

In several embodiments, the vinyl polymer is highly hydrolyzed polyvinyl alcohol of about 50 kg/mol to about 300 kg/mol molecular weight. The vinyl
5 polymer solution is about 1 weight percent (wt%) to about 50 wt% of polyvinyl alcohol based on the weight of the solution. In preferred embodiments, the vinyl polymer solution is about 10 weight percent to about 20 weight percent solution of polyvinyl alcohol based on the weight of the solution.

The first solvent is selected from a group of solvents having a low χ value that
10 is not sufficient to enable gelation. In several preferred embodiments, the first solvent is selected from the group including, but not limited to, of deionized water, dimethyl sulfoxide, a C₁ to C₆ alcohol and mixtures thereof.

The second solvent, the gellant, is selected from a group of solvents having the property that raises the χ value of the resultant mixture of gellant and vinyl
15 solution to $\chi > 0.5$ at a specified temperature. In several embodiments, the gellant is selected from the group including, but not limited to, for example, alkali salts, glycosaminoglycans, proteoglycans, oligomeric length hydrocarbons such as polyols, preferably polyethylene glycol, enzyme-cleavable biopolymers, UV-cleavable polymers, chondroitin sulfate, starch, dermatan sulfate, keratan sulfate, hyaluronic
20 acid, heparin, heparin sulfate, biglycan, syndecan, keratocan, decorin, aggrecan, perlecan, fibromodulin, versican, neurocan, brevican, a phototriggerable diplasmalogen liposome, amino acids such as, for example, serine or glycine, glycerol, sugars or collagen. The gellant can be added in the form of a solid or as an aqueous solution.

25 In one preferred embodiment, the gellant is added by being mixed with a solution of the vinyl polymer held at an elevated temperature, preferably above the melting point of the vinyl polymer. The melting point can be suitably determined by differential scanning calorimetry (DSC). With reference to the dashed curve illustrated in Fig. 6, for PVA, the elevated temperature is at least greater than 57
30 degrees Celsius, preferably greater than 80 degrees Celsius, more preferably greater than 90 degrees Celsius. In general, with reference to a graphical representation of differential scanning calorimetry results such as Fig. 6, the most preferred elevated

temperature is in the linear portion of the curve at temperatures above the melting point.

The resultant mixture begins to undergo a spinodal decomposition as it mixes and cools. The mixture is injected into a body cavity, whereupon it forms a load-bearing gel over a period of time.

In one preferred embodiment the solvent quality of the entire mixture of PVA, water and secondary or tertiary components has a Flory interaction parameter of $0.25 < \chi < 0.8$ and preferably in the range of $0.3 < \chi < 0.5$.

The preferred embodiments of the invention provide an injectable hydrogel that can be used for orthopedic therapies, including *nucleus pulposus* augmentation or replacement, and augmentation of load bearing surfaces in an articulated joint such as, for example, knee or hip. In the case of knee or hip augmentation, the injectable hydrogel can be used in early interventional therapy for those patients who, although in pain due to partial loss of articular cartilage, are not candidates for total knee or hip replacement.

The injectable hydrogel can also be used for non-load bearing applications for replacement, repair, or enhancement of tissue. It can also be used topically as a protective coating for burns or wounds. The preferred embodiments of the invention are especially suited to minimally invasive applications where small access holes in tissue are required. The access holes can have diameters of approximately 1-10 mm and can be located, for example, without limitation, in the *annulus fibrosus*, bone tissue, cartilage, or other tissues.

In another preferred embodiment, the gellant is added to a mixing solution of the vinyl polymer held at an elevated temperature. The resultant mixture begins to undergo a spinodal decomposition as it mixes and cools. This mixture can then be used to generate a hydrogel device to be manufactured using conventional processing means such as injection or compression molding, blow molding, calendaring, or any other suitable processing step. This device can then be implanted as a load bearing device, or some other non-load bearing device such as a nerve cuff or as part of a drug release system. This device can also be used in non-biological applications as protective hydrogel films, or sealing agents.

In another embodiment, the vinyl solution and gellant are not pre-mixed, but are co-injected through a tube via a mixing chamber having a tortuous path that facilitates mixing. The pre-cursor hydrogel can be injected using a suitable dispenser directly into the target location. Fig. 28A illustrates a flow chart of method 600 of forming a PVA hydrogel including the steps of providing a vinyl polymer and a first solvent in a chamber of a first dispenser per step 602; placing a gellant in a chamber of a second dispenser per step 604; mixing the vinyl polymer solution and the gellant in a mixing chamber per step 606 and heating the mixture to a temperature above the melting point of the vinyl polymer 608. The method then includes dispensing the mixture per step 610; delivering the mixture into a region of interest, such as a cavity, per step 612; and inducing gelation of the mixture per step 614 to form a PVA hydrogel in accordance with a preferred embodiment of the present invention. In certain embodiments, the step of providing a vinyl polymer and a first solvent includes the step of mixing the vinyl polymer and the first solvent. Similarly, in certain embodiments, the step of placing the gellant in a chamber of the second dispenser chamber includes the step of mixing the gellant and a second solvent.

Fig. 28B illustrates a flow chart of a method 620 of forming a PVA hydrogel in accordance with an alternate preferred embodiment. This method 620 is similar to the method 600 illustrated with respect to Fig. 28A however, the step of heating the polymer solution in a chamber of a first dispenser to a temperature above the melting point of physical associations in the polymer (step 626) precedes the step of mixing the vinyl polymer solution and the gellant in the mixing chamber (per step 628).

The step of inducing gelation as discussed with respect to the flow charts in Figs. 28A and 28B includes the modulation of temperature, in particular lowering the temperature of the mixture of the vinyl polymer solution and the gellant below the crystallization temperature (melting point of the physical association). In alternate preferred embodiments the step of inducing gelation includes the release of active gellants from an inactive gellant complex. The inactive gellant complex includes, without limitation, for example, enzyme cleavable polymers, heat denaturable polymers, thermal/chemical/photo/triggered liposomes or hydrogels; thermally triggered irreversible crystalline materials such as starches, and degradable polymers.

Fig. 28C illustrates a flow chart of a method 650 for forming a vinyl polymer hydrogel in accordance with a preferred embodiment of the present invention. The method 650 includes mixing a vinyl polymer and first solvent per step 652. The method 650 includes the step 654 of pouring the solution into one barrel of a multi-
5 barrel syringe, pouring a gellant into another barrel of the multi-barrel syringe per step 656, raising the temperature of the barrel above the melting point of the physical associations of the vinyl polymer per step 658, centrifuge the barrel per step 660, and injecting through a static mixture such as a cannula having a tortuous path the mixture into a region of interest, for example, into a joint space per step 662.

10 The method 650 includes in an alternate embodiment the step of 666 of mixing a gellant into a vinyl polymer solution, pouring the solution into a single barrel per step 668, raising the temperature of the barrel above the melting point of the vinyl polymer physical associations per step 670, centrifuging the barrel per step 672, and injecting the solution through a cannula or a syringe needle into the region
15 of interest per step 674. Prior to step 674, the single barrel can be stored at room temperature, under which conditions the vinyl polymer solution gels. The barrel can then be reheated above 80°C, remelting the gel, and injected into the region of interest per step 674. The steps of the method 650 can thus provide material such as *nucleus pulposus* augmentation for a intervertebral disk system. This gel in accordance with
20 the preferred embodiments conforms to the joint space or any region of interest.

Further, the method 650 includes for the different embodiments the following steps of inserting a closure device for a disk augmentation per step 664 or injecting concentrated gellant into an opening in the joint space to locally enhance the gelation rate and final mechanical properties per step 676 or per step 678 requiring no further
25 procedure post the injection of the gellant into the region of interest per steps 662, 674. The latter steps 664, 676, provide for the augmentation of, for example, the annulus fibrosis in a disk system.

Figs. 29A-29F schematically illustrate a method 700 for forming and dispensing a vinyl polymer hydrogel in accordance with a preferred embodiment of
30 the present invention. The method includes per Fig. 29A, a system being supplied in three aseptic containers or two containers wherein the contents of the containers A and B are combined. The aseptic cartridges contain PVA, solvent 1 (water) and

gellant, respectively, as illustrated in Fig. 29B. The two components are mixed in a sealed container at a temperature above 80°C. The components are then transferred to a single barreled holder 704 as illustrated in Fig. 29C and centrifuged whilst maintaining temperature to remove bubbles per Fig. 29D. As illustrated in Fig. 29E, 5 a nozzle or syringe needle is attached to the single barreled holder which is then assembled onto a plunger system that can be mechanically or electrically actuated (ratcheted) to deliver the mix solution. As described herein before, the mixed solution flows for a short period of time before becoming unworkable.

Figs. 30A-30F schematically illustrate a method for forming and dispensing a 10 vinyl polymer hydrogel in accordance with an alternate preferred embodiment of the present invention. As illustrated in Fig. 30A, the hydrogel system is supplied in three aseptic containers or two containers wherein the contents of containers A and B are combined. The aseptic cartridges contain PVA, solvent 1 and gellant, respectively. As illustrated in Fig. 30B, the PVA solution is mixed and heated and the gellant is 15 also heated in container C. The ingredients are then loaded into separate chambers of a twin barrel system while maintaining the elevated temperature as shown in Fig. 30C. The barrel system is then centrifuged and/or vacuum degassed and injected through a static mixer nozzle. As shown in Fig. 30E, a nozzle or syringe needle is attached and assembled onto a plunger system that can be mechanically or electrically 20 actuated (ratcheted) to deliver mix solution. The mixed solution flows for a short period of time before becoming unworkable.

Figs. 31A-31E schematically illustrate an alternative preferred method for forming and dispensing a vinyl polymer hydrogel in accordance with an embodiment of the present invention. This embodiment includes a hydrogel system being supplied 25 in a single cartridge. The aseptic double barreled cartridge illustrated in Fig. 31A contains PVA and solvent 1 in one and gellant in the other. The cartridge is heated to remelt the PVA in solution as shown in Fig. 31B. The system is then centrifuged and/or vacuum degassed and injected through a static mixer nozzle as shown in Fig. 31C. As illustrated in Fig. 31D, the nozzle or syringe needle is attached and 30 assembled onto a plunger system that can be mechanically or electrically actuated (ratcheted) to deliver the mixed solution. The mixed solution flows for a short period of time before becoming unworkable.

Fig. 32A schematically illustrates a dispenser 800 for providing a vinyl polymer hydrogel in accordance with a preferred embodiment of the present invention. The dispenser includes a first chamber 810; a second chamber 812; a first chamber piston rod 814; a second chamber piston rod 816; a housing 818; a movable lever 820; a fixed handle 822; a mixing chamber 830; a mixing chamber fitting 832; a dispensing tube 834; a dispensing tube fitting 836; a dispensing tube opening 838; a temperature controller 850; a connector 852; a mixing chamber heater/cooler 854; a chamber heater/cooler 856; and a dispensed mixture 860. In preferred embodiments, vinyl polymer solution and gellant are provided as premixed sterile solutions, preferably pre-packaged in first chamber 810 and second chamber 812, respectively. A heater/cooler 854 and 856 can include resistive heating, inductive heating, water jacket or Peltier effect heating/cooling elements. The temperature controller 850 can be integral with the dispenser 800, or a separate unit, connected by connector 852. The entire dispenser 800 can be sterile, preloaded and intended for a single use.

Fig. 32B schematically illustrates an embodiment of a single use container 808. The distal position of the dispenser 802 is adapted to receive the single use container 808. The single use container 808 has a first chamber 810 and a second chamber 812, in fluid communication a mixing chamber 830, which is in fluid communication with a dispensing channel 835. The first and second chambers may be identical, or as illustrated, different in size, having different diameters as appropriate to the specific type and concentration of the vinyl polymer and the gellant. The first chamber piston rod 814 and a second chamber piston rod 816 are part of the dispenser 802 and are operatively coupled to a controllable drive mechanism in the dispense, and contact the first chamber piston 848 and second chamber piston 849.

The dispenser housing 818 includes a chamber heater/cooler 856 that encompasses the first chamber 810 and the second chamber 812, a mixing chamber heater/cooler 854 that encompasses the mixing chamber 830 and a dispensing channel cooler 840 that surrounds the dispensing channel 835. The dispensing tube 834 is in communication with the dispensing channel 835 through a dispensing tube fitting 836.

In preferred embodiments, vinyl polymer solution and gellant are provided as premixed sterile solutions, preferably pre-packaged in first chamber 810 and second chamber 812, respectively of the single use container 808. Typically, the first chamber 810 and second chamber 812 are sealed by distal seals 844 and proximal seals 846 to prevent alteration or contamination of the vinyl polymer solution and gellant. The heater/cooler 854 and 856 can include resistive heating, inductive heating, water jacket or Peltier effect heating/cooling elements. The dispensing channel cooler 840 can include water jacket or Peltier effect cooling elements, and can be used to control the delivery temperature of the viscoelastic polymer solution. The single use container 808 is typically sterile, preloaded and intended for a single use. The dispenser 802 may be single use or sterilizable, and can be used to dispense the contents of multiple single use containers.

In another preferred embodiment, drugs can be mixed with either the vinyl polymer solution or the gellant so that the resultant injected gel contains an encapsulated drug that can release over time.

In yet another preferred embodiment, a small amount of free radical scavenger is added to the vinyl polymer solution in a concentration of approximately 1 to 1000 parts per million. The free radical scavenger can be any common free radical scavenger known to those skilled in the art, but can include Vitamin E and hydroquinones. The purpose of the free radical scavenger is to minimize the effects of ionizing radiation, either gamma or electron beam (e-beam), which may be used to sterilize the material prior to use. Radiation can either crosslink or cause scissioning in PVA solutions depending on the concentration of the solution.

In another embodiment, the final mechanical properties of the hydrogel can be tailored by varying the initial starting concentration of the vinyl polymer solution, and the concentration of the gellant in the final mixture.

In another series of embodiments, the generation of conditions conducive to force the gelation of the PVA entail the internal release of active ingredients or sequestered materials which can comprise any combination of or, single gellant listed herein before. To change the theta-point of the solvent relative to the PVA, or to alter the co-nonsolvency of the solvent relative to PVA, there exist potential methods based on the sequestration of "active" molecular species. Such mechanisms serve to

rapidly release the sequestered active molecular species to achieve local changes in solvency. If enough of the sequestering moieties are distributed through the system, it is possible to effect a global change in solvency. Such a method would serve to alleviate precipitation problems associated with mixing the PVA with a particularly active gellant. Suitable sequestration systems are available, including liposome sequestration, polymer sequestration, crystalline sequestration, gel encapsulation and degradable encapsulation

In a preferred embodiment, liposome sequestration uses lipid vesicles to separate their contents from the external environment. This system has been used successfully to induce rapid gelation of polysaccharide and protein hydrogels. Lipid vesicles can be induced to release their contents by either thermal or phototriggering methods. In preferred embodiments, the gelation of a PVA solution prepared according to the present invention can be accelerated following application of a suitable trigger. A suitable trigger can be the gel/liposome composition heated to body temperature. In a preferred embodiment of the present invention, an aqueous PVA solution is mixed with a suspension of thermally triggerable liposomes containing a concentrated NaCl solution or solid NaCl at a temperature below that necessary to induce release of the NaCl. Upon injection into a region of interest such as a body cavity at or near 37°C, the liposomes release the contained NaCl, changing the Flory parameter of the solution and causing gelation of the PVA. In other embodiments, other suitable gellants can be sequestered in the lipid vesicles to influence the gelation rate of PVA.

In another preferred embodiment, the sequestration system is based on the increase of colligative activity of a polymer by cleavage of the polymer into multiple smaller fragments. In some complex polymer systems, degradation produces fragments that are more soluble than the original molecule, for example, collagen. Such an increase in smaller, more active components shifts the solvency of the overall solution to induce the gelation of PVA. Some examples of suitable polymeric sequestration systems (and their enzymatic cleaving complements) are listed, without limitation, in the table below. The table is not inclusive however the polymer sequestration concepts are intended to include all polymers, in particular, biocompatible polymers or biopolymers, and their particular polymer degradation

mechanisms. In a further embodiment, the two above approaches can be combined, using triggered liposomes to sequester the appropriate enzymes to produce triggerable cleavage of the gellant.

In one embodiment, fully formed purified type I collagen fibrils can be mixed with PVA solution at temperatures below the denaturation temperature of the collagen. The solution can be heated to induce the denaturation of the collagen fibrils which would release soluble gelatin molecules into the PVA, changing the relative solubility of the PVA and potentially inducing PVA gelation.

Table 2
Specific Cleavage Methods for Selected Gellants

Polymer	Degradation mechanism	Degradation specifics Or enzyme complement
Collagen Type I	Heat denaturation	Temperature 40-90°C
Collagen Type I	Enzyme cleavage	Collagenase (MMP I)
All remaining collagens	Heat denaturation	Temperature 40-90°C
All remaining collagens	Enzyme cleavage	All MMP complements (MMPs 3-20)
Hyaluronic Acid	Enzyme cleavage	Testicular Hyaluronidase Hyaluron lyase
Chondroitin Sulfate	Enzyme cleavage	Chondroitinase family
Heparin	Enzyme cleavage	Heparinase I/III
All remaining glycosaminoglycans	Enzyme cleavage	GAG enzyme complements
Aggrecan	Enzyme cleavage	Aggrecanase
All remaining Proteoglycans	Enzyme cleavage	PG enzyme complements

10

In another preferred embodiment, the sequestration method entails the confinement of active moieties in crystals that can be melted irreversibly, producing a large change in the activity of the crystalline component. In one preferred embodiment the crystalline component is a starch, comprising amylase molecules, amylopectin molecules or mixtures thereof that are linear and branched multimers of glucose. Starch particles normally comprise crystalline and amorphous regions. Upon heating in solution, starch particles absorb water readily and, upon gelatinization, the starch particles become highly osmotically active. When returning to room temperature, starches gelatinize, but not recrystallize. Thus, PVA can be mixed effectively with crystalline starch granules to make a solution where the PVA

20

is soluble. However, upon heating above the gelatinization point of the starch and recooling, the PVA would be forced to gel because of the competition for solvent with the gelatinized starch which is more hygroscopic.

In another embodiment, the sequestration method involves the use of gel-
5 based capsules, which upon a suitable trigger (for example, without limitation, pH, ionic concentration, temperature, radiation) release their encapsulated contents. In a further embodiment, the sequestration method involves the trapping of the active molecules in a degradable matrix. In preferred embodiments, a suitable biodegradable polymer can be selected from the group including, but not limited to, a
10 poly(L-lactide), a poly(D,L-lactide), a poly(lactide-co-glycolide), a poly(ϵ -caprolactone), a polyanhydride, a poly(beta-hydroxy butyrate), a poly(ortho ester) and a polyphosphazene.

In general, a suitable gellant in accordance with the preferred embodiments is a solute that is water soluble, has a higher affinity for water than PVA. In preferred
15 embodiments, a solid gellant or an aqueous solution of gellant is added to an aqueous PVA solution. Typically PVA solutions in the range of from about 1 weight % to about 50 weight % PVA are prepared by adding the desired amount of PVA to warm deionized water while mixing. For example, a 20% PVA solution by weight is prepared by dissolving 20 g of PVA (100 kg/mole; 99.3+% hydrolyzed; JT Baker) in
20 80 g of deionized water heated in a water bath to a temperature of greater than 90 degrees Celsius with continuous stirring for a minimum of 15 minutes using a vortex mixer (VWR BRAND). The PVA solution obtained was substantially clear when fully dissolved and melted. The solution was placed in a covered container to avoid evaporation, optionally under a mineral oil protective layer.

In one preferred embodiment, 1.4 g of 400 molecular weight poly(ethylene glycol) (PEG400, Sigma Aldrich) was added gradually to 6.0 g of 10% by weight
25 PVA solution was stirred while stirring on a hot plate at 50 degrees Celsius and then the jar was shaken. After initially producing an inhomogeneous solution whilst adding the material became homogeneous and rapidly opaque. The final gel was (by
30 weight) 8% PVA, 19% PEG 400 and 73% water. Figs. 22A-22D show the product at four time durations after the end of mixing: Fig. 22A, zero minutes; Fig. 22B, 15

minutes; Fig. 22C, 2 hours, under a mineral oil protective layer; and Fig. 22D, one day, out of the jar.

In one preferred embodiment, a PVA hydrogel was prepared by adding 35.6 g of aqueous 10 wt% PVA solution to 18.7 g of aqueous 5.1 M NaCl while mixing, and the resulting mixture aggressively shaken. The solution was briefly inhomogeneous before becoming smooth and transparent. Over the period of 16 hours the solution became gradually more opaque and gelled. The final gel was 7 wt% PVA, 8 wt% NaCl and 85 wt% water. Figs. 23A-23E illustrate the PVA hydrogel prepared, showing the product at five time durations after pouring into a covered dish and a flexible bag: Fig. 23A, zero minutes; Fig. 23B, 20 minutes; Fig. 23C, 1 hour; Fig. 23D, 2 hours; and Fig. 23E, 17 hours. Note that the solution was fluid for long enough that a circular shape was easily formed. The solution was also cast in a flexible bag to demonstrate its abilities for space filling applications in deformable environments.

In another embodiment, an aqueous 10 wt% PVA solution was placed in the larger barrel of a 4:1 ratio epoxy adhesive gun (3M). Poly(ethylene) glycol with a molecular weight of 400 g/mol was placed in the smaller barrel. The resulting blend was delivered through a 3 inch static mixing nozzle (3M) into a mold held at room temperature. The resulting mix had 8 wt% PVA, 20 wt% PEG 400 and 72 wt% water. The resulting mixture was observed to gel inhomogeneously on delivery, but with time resulted in a homogeneous opaque gel.

In a further preferred embodiment, a PVA hydrogel was prepared by adding NaCl to an aqueous 10 wt% PVA solution at about 95 degrees Celsius (Fig. 24A) while mixing to make a final concentration of 2M NaCl. After approximately 15 minutes, the resulting solution was smooth and homogeneous (Fig. 24B). The PVA solution obtained was poured into two jars, one of which was equilibrated at room temperature (Fig. 24C, 15 minutes; Fig. 24E, one hour), the other of which was placed on shaved ice (Fig. 24D, 15 minutes; Fig. 24F, one hour). The solution was initially cloudy, but homogeneous. After 1 hour, the gel cooled at room temperature was slightly cloudy, whereas the ice-cooled gel was predominantly transparent.

The two samples were then stored at room temperature. The final resulting gels after one month exhibited significant syneresis and visually looked identical, but the rapidly cooled material appeared to turn opaque much faster.

Figs. 25A-25F illustrate the PVA hydrogels of Figs. 24A-24F after storage.

5 Fig. 25A, cooled one hour at room temperature and stored 12 hours at room temperature; Fig. 25B, cooled one hour on ice and stored 12 hours at room temperature; Fig. 25C, cooled one hour at room temperature and stored one month at room temperature; Fig. 25D, cooled one hour on ice and stored one month at room temperature; Fig. 25E, the PVA gel of Fig. 25C, oriented to show water released due to syneresis; and Fig. 25F, the PVA gel of Fig. 25D, oriented to show water released
10 due to syneresis.

In preferred embodiments, the present invention provides a method for early treatment of joint disease by providing a polymer cushion formed *in situ* between load-bearing surfaces in the joint. In one preferred embodiment, a PVA cushion is
15 formed *in situ* within the hip joint by dislocating the head of the femur, filling the exposed cavity within the joint with a fluid solution of PVA and gellant, replacing the head of the femur and allowing the PVA solution to gel *in situ*. In an example, illustrated in Figs. 26A-26D, dry NaCl was added at a moderate rate to a 20 wt% aqueous PVA solution warmed in a water bath at about 95 degrees Celsius with
20 continuous stirring to make a 2.1 M NaCl solution. After 1 minute the resulting solution was smooth and malleable, resembling taffy. Resulting solution was removed from the mixer and placed in a chilled polyethylene liner from a Total Hip Replacement (THR) system. The matching cobalt-chrome ball from the THR joint inserted into the liner socket and allowed to stand for 1 hour at room temperature.
25 The mold was then placed in deionized water for a further 1 hour, whereupon the ball was removed from the poly(ethylene) liner. At this point a thin, homogeneous and substantially blemish-free hemisphere of PVA was obtained. Fig. 26A shows the mold formed by the chilled polyethylene liner and the matching ball from a total hip replacement joint. Fig. 26B shows the mold after filling the chilled polyethylene liner with the PVA solution and putting the matching ball in place. Fig. 26C shows the
30 molded PVA in the polyethylene liner after one hour in air at room temperature

followed by one hour in deionized water at room temperature. Fig. 26D shows the molded PVA product removed from the polyethylene liner.

Since the mechanism of gelation is chemically non-specific, it is possible to use virtually any solute that has sufficient osmotic activity to force PVA self-
5 association. In a further preferred embodiment, the co-nonsolvency was exploited by using a naturally-occurring biocompatible material as a gellant to form a PVA gel. Chondroitin sulfate (CS, Now Foods Bloomingdale, IN) was used to induce the gelation of polyvinyl alcohol. Aqueous 10 wt% PVA solution was prepared and stored at 60°C until use. In a first example, warm chondroitin sulfate solution
10 (~80°C) was added to the warm PVA solution to generate a 5 wt% PVA, 7 wt% CS mixture. Upon cooling to room temperature, the mixture formed a weak gel over a period of two days that remained stable (Fig.27A). In the second example, 600 mg CS was added directly with continuous stirring to 10 ml of 10 wt% PVA solution at 60 degrees Celsius. Compared to the previous example, the mixture formed a much
15 stiffer gel within minutes and remained stable (Fig.27B). The success of inducing the gelation of PVA using a biocompatible material that is typically present in the joint space suggests the possibility of *in situ* joint repair or augmentation.

In a further example, serine, a common amino acid in the blood stream of humans was dissolved in deionized water to produce a 30 wt% aqueous solution. The
20 PVA solution and serine solution were then combined in equal parts by volume at less than 90 degrees Celsius and mixed thoroughly, resulting in a solution of 10% PVA, 15% serine and 75% water. The solution stayed fluid while at the higher temperature but as it cooled it gradually gelled, producing a gel after about 1 hour.

In a preferred embodiment, the vinyl polymer solution may include, without
25 limitation, mixtures of vinyl polymers such as polyvinyl alcohol and polyvinyl pyrrolidone (PVP) or copolymers of PVP, as described in the European Patent specification EP 1229 873 B1, the entire teachings of which are incorporated herein by reference.

In a preferred embodiment, the vinyl polymer solution may include any
30 mixture of components that form physical associations through manipulation of relative solvent quality.

In a preferred embodiment, the vinyl polymer solution may include a nano or microstructuring agent which can include nano and microparticulates such as clay or silica, charged or uncharged, and/or nanostructuring functionalized molecules such as POSS as described herein before. These nano or microparticulates provide nucleation sites that accelerate or augment the gelation process. Preferred embodiments of the present invention benefit from this recognition that nucleation sites provided by any particles of the appropriate size in the vinyl polymer solution augment gelation to result in a gel of the desired mechanical properties.

Repair of Damaged Intervertebral Disks

In preferred embodiments, the method and dispenser of the present invention are used in the repair of a damaged intervertebral disk. Fig. 33 is a schematic illustration of a midsagittal cross-section 900 through two vertebrae, each vertebra having vertebral body 920 and spinous process 922; the two vertebral bodies enclosing an intervertebral disk 910 comprising *annulus fibrosus* 912, *nucleus pulposus* 914 and herniation 916; provided for orientation are vertical axis 930, anterior-posterior axis 932 and arrow 938 indicating posterior access path to the herniation 916. Fig. 34 is a schematic illustration of a transverse section 940 through a damaged intervertebral disk 910, showing spinous process 922 and transverse process 924 of an adjacent vertebra, *annulus fibrosus* 912, *nucleus pulposus* 914, the outline of the spinal cord 942 and herniation 916 protruding through defect 918.

Briefly, the damaged intervertebral disk is repaired by respecting the herniated region, injecting a viscoelastic solution of the vinyl polymer hydrogel of the present invention to replace part or substantially all of the *nucleolus pulposus* material, controlling the rate of gelation of the vinyl polymer hydrogel by methods described herein before, and closing the injection site. The viscoelastic solution of the vinyl polymer hydrogel can be injected through a defect in the *annulus fibrosus* at the site of the herniation, and/or through another point of the *annulus fibrosus*. The injection site and the defect can be closed by modifying the local physical properties of the hydrogel by a further application of gellant *in situ*, as described herein before. Alternatively, the injection site and the defect can be sealed and reinforced by the use of known medical devices to seal, reinforce or close the injection site or other defect of the body cavity. Suitable such devices are disclosed in published International

Patent Applications WO 01/12107 and WO 02/054978, which are hereby incorporated by reference in their entirety.

Fig. 35 is an illustration of a step in a method for the repair of a damaged intervertebral disk 910 in accordance with a preferred embodiment of the present invention, showing in transverse section 960 a spinous process 922 and a transverse process 924 of an adjacent vertebra, *annulus fibrosus* 912, *nucleus pulposus* 914, the outline of the spinal cord 942 and dispensing tube 934 introduced through defect 918, dispensing the viscoelastic mixture of gellant and vinyl polymer 952. In preferred embodiments, the local physical properties of the hydrogel are adjusted by an addition of a gellant through the same dispensing tube 934 following the dispensing of the desired amount of viscoelastic mixture of gellant and vinyl polymer. The additional gellant can be the same or different from the gellant initially mixed with the vinyl polymer solution.

In alternative embodiments, a sealer can be used to supplement or instead of modifying the local physical properties of the hydrogel by an addition of a gellant. Fig. 36 is a schematic illustration of a step in the repair in accordance with a preferred embodiment of the present invention of a damaged intervertebral disk 910, showing in transverse section 962 a spinous process 922 and a transverse process 924 of an adjacent vertebra, *annulus fibrosus* 912, *nucleus pulposus* 914, the outline of the spinal cord 942, defect 918, mixture of gellant and vinyl polymer 952, sealant 970, fixative 918, a fixative delivery instrument 950. The sealant 970 is constructed from a material and is formed in such a manner as to resist the passage of fluids and other materials around the sealant 970 and through the defect 918. The sealant 970 can be constructed from one or any number of a variety of materials including, but not limited to, polytetrafluoroethylene (PTFE), expanded polytetrafluoroethylene (e-PTFE), NYLON™, MARLEX™, high density polyethylene, and/or collagen. See WO 02/054978, incorporated herein by reference. After placement of the sealant 970, fixative 918, such as sutures or soft tissue anchors, are placed using fixative delivery instrument 950.

In alternative embodiments, a barrier can be used. Fig. 37 is a schematic illustration of a step in the repair in accordance with a preferred embodiment of the present invention of a damaged intervertebral disk 910, showing in transverse section

964 a spinous process 922 and a transverse process 924 of an adjacent vertebra, *annulus fibrosus* 912, *nucleus pulposus* 914, the outline of the spinal cord 942, defect 918, mixture of gellant and vinyl polymer 952, barrier 974, fixative 972, and fixation delivery instrument 950. The barrier 974 is preferably flexible in nature, and can be constructed from a woven material such as DACRONTM or NYLONTM, a synthetic polyamide, polyester, polyethylene, PVA fiber, and may be an expanded material such as e-PTFE. Alternatively, the barrier 974 can be a biologic material such as collagen. The barrier 974 can be expandable such as, for example, a balloon or a hydrophilic material. See WO 02/054978. The barrier could also be a thin membrane of PVA hydrogel manufactured *in vitro*.

If appropriate the viscoelastic solution of the present invention is introduced at a site other than the defect. Fig. 38A is a schematic illustration of a step in the repair in accordance with a preferred embodiment of the present invention of a damaged intervertebral disk 910, showing in transverse section 968 a spinous process 922 and a transverse process 924 of an adjacent vertebra, *annulus fibrosus* 912, the outline of the spinal cord 942, defect 918, mixture of gellant and vinyl polymer 952 substantially filling the space previously occupied by the *nucleus pulposus*, barrier 976, and dispensing tube 934.

Fig. 38B is an illustration of a step in a method for the repair of a damaged intervertebral disk 910 in accordance with a preferred embodiment of the present invention, showing in transverse section 969 a spinous process 922 and a transverse process 924 of an adjacent vertebra, *annulus fibrosus* 912, *nucleus pulposus* 914, the outline of the spinal cord 942 and dispensing tube 934 introduced through defect 918, dispensing the viscoelastic mixture of gellant and vinyl polymer 952, and a cooling probe 934. In such preferred embodiments, the gelation of viscoelastic mixture of gellant and vinyl polymer can be controlled by adjusting the temperature using cooling probe 936. The cooling probe 936 may be in contact with, and optionally affixed to, the dispensing tube 934, or may be separate and independently positioned. In some embodiments in which the cooling probe 936 is in contact with the dispensing tube 934, the area of contact can be insulated and the cooling effect localized to the tip of the probe 936, facilitating gelation of the hydrogel at the point of delivery. In other embodiments, the area of contact is not insulated, permitting the

control of the delivery temperature and the gelation of viscoelastic mixture of gellant and vinyl polymer.

In certain preferred embodiments, the vinyl polymer is PVA and the gellant is polyethylene glycol. The procedure for preparing all relevant weight fractions of PVA is similar. Concentrations of each component are weight percent, measured relative to the water component only. For example, to make an 20 weight percent PVA solution by weight, 20 g of PVA (100 kg/mole; 99.3+% hydrolyzed; Mallinckrodt Baker Inc., Phillipsburg, NJ) was dissolved in 80 g of deionized water at 90+ °C in a water bath for a minimum of 15 minutes using a vortex mixer (VWR International, West Chester, PA) to stir continuously. Once the PVA was fully dissolved and melted, the solution was substantially clear. Evaporation of the solution was minimized by use of appropriate covers.

Solutions of various concentrations of PVA (3, 5, 7.5, and 10% weight percent relative to water) were gelled with 20 % polyethylene glycol (400 g/mole, weight percent relative to water) as gellant. The PVA content of the final gel was determined gravimetrically by weighing the gel, dehydrating, and weighing the dehydrated gel. In general, more crosslinking would produce a greater amount of PVA in the final gel. The lower starting PVA concentrations resulted in hydrogels that were fairly independent of starting concentration, whereas the hydrogel formed from a 10% starting solution had a relatively higher final PVA content.

Table 3
Effect of the Starting PVA Concentration on the Final PVA Concentration in the Hydrogel

PVA concentration in starting solution (weight % of water)	Final PVA concentration in hydrogel (weight % of water)
3%	7%
5%	7%
7.5%	7%
10%	9%

Fig. 39 illustrates a group 1000 of vials containing PVA hydrogels prepared from various concentrations of PVA (3, 5, 7.5, and 10% weight percent relative to water component) and gelled with 20 % polyethylene glycol (400 g/mole, weight percent relative to water) as gellant. The hydrogels formed from 3 weight percent

PVA 1002, 5 weight percent PVA 1004 and 7.5 weight percent PVA 1006 showed similar opacity, consistent with the similar PVA concentration in the final hydrogel; see Table 3, above. In contrast, the hydrogel formed from 10 weight percent PVA 1008 appeared more opaque and had a relatively higher PVA concentration in the final hydrogel; see Table 3, above.

The effect of the starting PVA concentration on gelation kinetics was studied. The gellant polyethylene glycol (400 g/mole, final concentration of 25 weight percent relative to water in the starting PVA solution) was added with mixing to aqueous solutions of polyvinyl alcohol (100,000 g/mole) with starting concentrations in water of 10, 15, 20 and 25 weight percent PVA relative to water. The polyethylene glycol was added to a final concentration of 25 weight percent relative to the water in the PVA solution. The gelation time of the solutions was measured empirically by determining when the solution first went cloudy, when it was deemed opaque, when it ceased to flow, and when it was physically solid. Higher concentrations resulted in faster gelation (time measured in minutes from start of mixing with polyethylene glycol).

Table 4
Effect of the Starting PVA Concentration on Gelation Kinetics

PVA Concentration in starting solution	Time to reach condition [minutes]			
	Cloudy	Opaque	Flow ceased	Physical Solid
10%	15	20	30	60
15%	15	17	25	40
20%	21	23	30	40
25%	<5	<5	<5	<5

The effect of the starting gellant concentration on gelation kinetics was also studied. A polyvinyl alcohol (100,000 g/mole) solution of 10 weight percent relative to water was mixed with various concentrations of polyethylene glycol (400 g/mole) to achieve a final PEG concentration relative to the water component of the PVA solution as shown in Table 5, below. The gelation time of the solutions was measured empirically by determining when the solution first went cloudy, when it was deemed opaque, when it ceased to flow, and when it was physically solid. Higher

concentrations resulted in faster gelation (time measured in minutes). The higher concentrations of PEG gellant were observed to form stiffer hydrogels.

Table 5
Effect of the Gellant Concentration on Gelation Kinetics

PEG Concentration	Time to reach condition [minutes]			
	Cloudy	Opaque	Flow ceased	Physical Solid
20%	30+	<120	>240	NA
25%	10	15	40	75
30%	5	10	30	45
35%	2	5	15	30

As discussed in detail above, the solvent quality of the active gellant governs the way the PVA chain interacts with the aqueous environment. A common technique for measuring this interaction of the polymer chain with the aqueous environment activity is determining the swelling of a hydrogel in a solvent. A "good" solvent causes the hydrogel to swell, a "bad" solvent causes the hydrogel to shrink. A 10% PVA freeze-thaw gel was made up using standard techniques. This hydrogel was then placed in various concentrations of PEG of number of molecular weights as well as a solution of NaCl. The resulting data are shown in Figure 40. Fig. 40 is a graphical illustration of the results of a study in which a 10% PVA freeze-thaw gel was placed in various concentrations of PEG of number of molecular weights (open triangles = 200 g/mole, filed circles = 400 g/mole, open squares = 600 g/mole, filled triangles = 1000 g/mole, filled diamonds = 1500 g/mole and filled squares 20,000 g/mole) as well as a solution of NaCl (open circles). Curves that are further to the left on the plot indicate that the active ingredient required less mass to obtain the same swelling (and hence solvent quality) behavior.

If a fixed swell ratio is taken for the PEG data, an equivalent concentration versus PEG molecular weight can be obtained. Fig. 41 is a graphical illustration of the results of a study of Fig.40 plotted to show the concentration of PEG of a given molecular weight that would be equivalent in effect to a 20 weight percent solution of PEG 400.

In certain preferred embodiments, a radiopaque substance is added to the hydrogel to increase its visibility in procedures performed or evaluated using diagnostic radiology techniques such as fluoroscopy, CT or other x-ray techniques.

Suitable radiopacifer compounds include inorganic or organic compounds containing barium, bismuth, bromine, iodine, iodide, silver, tantalum, thorium, titanium, tungsten, zirconium, and combinations thereof. Exemplary inorganic radiopacifer compounds include barium sulfate, bismuth oxide, bismuth oxychloride, bismuth subcarbonate, bismuth subnitrate, bismuth trioxide, silver iodide, thorium oxide, titanium oxide, zirconium oxide and mixtures thereof. Exemplary organic radiopacifer compounds include diatrizoates, such as diatrizoate sodium and diatrizoate meglumine, iodinated organic compounds such as iobenzamic acid, iocarmic acid, iocetamic acid, iodipamide, iodixanol, iohexol, iopromide, iopamidol, iothalamate, ioversol, ioxaglate, metrizamide and mixtures thereof. In certain preferred embodiments, the radiopacifier is mixed with the vinyl polymer solution and gellant, producing upon gelation, a radiopaque hydrogel. In other embodiments, the hydrogel can be loaded with a first solution of inorganic ions, such as potassium iodide, and then contacted with a second solution of inorganic ions, such as silver nitrate, thereby precipitating radiopaque particles *in situ* within the hydrogel. See Horak, D., et al., Radiopaque poly(2-hydroxyethyl methacrylate) particles containing silver iodide complexes tested on cell culture. *Biomaterials*. 1998 Jul;19(14):1303-7. Alternatively, a halogenated chain extender can be incorporated into the polymer matrix using techniques known in the art. See also Horak, D., et al., New radiopaque polyHEMA-based hydrogel particles. *J. Biomed. Mat. Res.* 1997 34:183-188.

In one preferred embodiment of the present invention, a radiopaque hydrogel was prepared as follows. An aqueous PVA solution (10 weight percent relative to the water component) was mixed with barium sulfate (final concentration 10 weight percent relative to the water in the starting PVA solution) and polyethylene glycol (400 g/mole, final concentration 25 weight percent relative to the water in the starting PVA solution) using the techniques above and the mixture was placed in a syringe. The mixture was allowed to gel completely. The syringe was then heated to a temperature of 95°C. The resultant liquid solution was then injected according to the method of the present invention as described above into the evacuated cavity of the *nucleus pulposus* of a porcine intervertebral disc. The material was allowed to gel resulting in a radiopaque hydrogel that could be visualized radiographically. Fig. 42 is a portion of radiograph 1100 of a portion of a porcine vertebral column, showing

an intervertebral disc 910 bounded by the vertebral bodies 1102, 1104 of adjacent vertebrae and showing the radiopaque hydrogel 1120 prepared with barium sulfate as described above that was injected into the evacuated nucleus cavity of the intervertebral disc 910. Fig. 43 is a photograph 1200 of a dissected portion of a porcine vertebral column, showing an intervertebral disc 910, *annulus fibrosus* 912, evacuated *nucleus pulposus* cavity 1212, and a cast of radiopaque hydrogel 1220 prepared with barium sulfate that was removed from the evacuated nucleus cavity 1212, and shown resting on a scalpel blade 1202.

In another preferred embodiment of the present invention, a radiopaque hydrogel was prepared by substituting 10 wt% of iodine for the barium sulfate in the protocol described above. The resultant hydrogel is temporarily radiopaque until the iodine diffuses out of the hydrogel.

In further embodiments, the hydrogel can contain PVA of different molecular weights. For example, a 20 wt% solution of PVA in water is prepared by mixing equal portions of a high molecular weight PVA (100,000 g/mole) and a low molecular weight PVA (20,000 g/mole) with water. This PVA solution is then gelled by adding a gellant that is a mixture of different molecular weight polyethylene glycols (400 - 1500 g/mole) to form a hydrogel.

In further embodiments, the present invention provides a radiopaque hydrogel suitable for use in the preparation of medicament for treatment of a vertebrate subject, such as orthopedic procedures performed on a human patient. In general, an aqueous PVA solution (5-50 wt%) is prepared and mixed with a gellant such as polyethylene glycol (molecular weight range of 50-10,000 g/mol) at a desired concentration (5-50 wt%) at an elevated temperature using the techniques described above and then placed into a delivery device such as a syringe. The delivery device preferably comprises a single use container for the vinyl polymer and the gellant. Preferably an inorganic radiopacifier such as barium sulfate or an organic radiopacifier such as such as iopromide (N, N'-bis(2,3-dihydroxypropyl)-2,4,6-triiodo-5-[(methoxyacetyl)amino]-N-methyl-1,3-benzenedicarboxamide, ULTRAVIST® Berlex, Montville, NJ) is also added to the solution prior to cooling to room temperature. The delivery device is sealed so as not to lose the gellant until use.

The mixture is cooled and allowed to form a gel. Preferably the gel is aged at room temperature or at a temperature below room temperature for a desired duration (1 hour-1 month). The gel is then sterilized with ionizing radiation (such as gamma or electron beam).

5 Before use the delivery device, or when present, the single use container is heated to melt the gel to form an elastomeric polymer solution. The elastomeric polymer solution is delivered to a body cavity of the subject, typically by injection through a needle or cannula of appropriate size. Preferably the elastomeric polymer solution is forced to flow through a heat sink between the single use container and the
10 needle or cannula to cool the melted gel to less than 60°C, preferably no more than 50°C, more preferably to about 37°C. Optimally, the elastomeric polymer solution is delivered at a temperature within a few degrees Celsius of the temperature of the tissue surrounding the body cavity. In some embodiments, the elastomeric polymer solution is delivered at a temperature less than about 25°C, more preferably less than
15 about 10°C.

In preferred embodiments, the hydrogel mixture is injected into a body cavity such as a cavity within the *nucleus pulposus*, between the femoral head and acetabulum, or within the meniscal area of the knee, the wall of the heart, nerve tissue, the joint spaces in the shoulder, elbow, ankle, wrist, fingers, and toes, breast,
20 and skull.

In other embodiments, the aqueous PVA solution (5-50 wt%) is prepared and preferably mixed with a radiopacifier as described above. In preferred embodiments, the PVA mixture is placed into a chamber of a single use container having at least two chambers, and comprising at least part of a delivery device, e.g., a dual-barrel
25 syringe. The gellant is placed in another chamber of the single use container. The delivery device is then sterilized with ionizing radiation (such as gamma or electron beam).

Before use the delivery device, or when present, the single use container, is heated. The two components, PVA mixture and gellant, are mixed and delivered into
30 the body cavity through a needle or cannula of appropriate size. Preferably the heated PVA mixture and gellant are forced to flow through a mixing device between the delivery device and the needle or cannula to mix the PVA mixture with the gellant

and form an elastomeric polymer solution. The mixing device can also act as a heat sink to cool the heated mixture the melted gel to less than 60°C, preferably no more than 50°C, more preferably to about 37°C. Optimally, the elastomeric polymer solution is delivered at a temperature within a few degrees Celsius of the temperature
5 of the tissue surrounding the body cavity. If a dual-barrel syringe is used, the diameters of the barrels on the dual-barrel syringe can be sized to achieve the desired concentration of the gellant mixed with the PVA solution.

In further embodiments, the aqueous PVA solution (5-50 wt.%) is prepared and mixed with a gellant such as polyethylene glycol (molecular weight range of 50-
10 10,000 g/mol) at a desired concentration (5-50 wt.%) at an elevated temperature using the techniques described above and then placed into a delivery device or single use container such as a syringe. Preferably the individual components are sterilized beforehand by any suitable means, such as irradiation, ethylene oxide or any other method known to one skilled in the art. The mixture is then cooled to form a gel.
15 Preferably a radiopacifier is also added to the solution prior to cooling to room temperature. The delivery device is sealed so as not to lose the gellant until use. Preferably the gel is aged at room temperature or at a temperature below room temperature for a desired duration (1 hour-3 months).

In other embodiments, the aqueous PVA solution (5-50 wt%) is prepared and
20 preferably mixed with a radiopacifier as described above. In preferred embodiments, the PVA mixture is placed into a chamber of a single use container having at least two chambers, and comprising at least part of a delivery device, e.g., a dual-barrel syringe. The gellant is placed in another chamber of the single use container. The delivery device is then sterilized with ionizing radiation (such as gamma or electron
25 beam). Before use the delivery device, or when present, the single use container, is heated. The two components, PVA mixture and gellant, are mixed and delivered into the body cavity through a needle or cannula of appropriate size. Preferably the heated PVA mixture and gellant are forced to flow through a mixing device between the delivery device and the needle or cannula to mix the PVA mixture with the gellant
30 and form an elastomeric polymer solution.

In other embodiments, the method of delivering the elastomeric polymer solution can further include the step of cooling the elastomeric polymer solution *in*

situ after placement within a body cavity. After the elastomeric polymer solution is injected a narrow heat sink or “cooling probe” is placed through the surgical access hole, through the in-place cannula, for example. This cooling probe could be a thermally conducting rod connected to a heat-sink external to the body, or it could be a portion of circulation system for a fluid, such as a thin stainless-steel tube carrying a fluid such as saline at the desired temperature. This cooling probe would be maintained in place long enough to ensure that the entire vinyl polymer solution in the cavity was chilled to less than 60°C, preferably no more than 50°C, more preferably to about 37°C, optimally, to a temperature within a few degrees Celsius of the temperature of the tissue surrounding the body cavity. In another embodiment the cooling probe could be used to chill the polymer solution to less than 37°C, more preferably less than 20°C, more preferably less than 5°C.

The claims should not be read as limited to the described order or elements unless stated to that effect. Therefore, all embodiments that come within the scope and spirit of the following claims and equivalents thereto are claimed as the invention.

We claim:

1. An article of manufacture comprising:
 - a single use container having at least one chamber;
 - a first chamber containing a vinyl polymer solution comprising a vinyl
 - 5 polymer dissolved in a first solvent; and
 - a gellant, wherein combining the gellant with the vinyl polymer solution produces a resulting mixture that has a higher Flory interaction parameter than the vinyl polymer solution.
2. The article of manufacture of claim 1 wherein the first chamber contains a
- 10 mixture of a gellant and a vinyl polymer solution comprising a vinyl polymer dissolved in a first solvent.
3. The article of manufacture of claim 1 further comprising a second chamber containing the gellant.
4. The article of manufacture of claim 3 further comprising a third chamber in
- 15 functional communication with the first chamber and the second chamber and having an outflow, wherein vinyl polymer solution from the first chamber and gellant from the second chamber are mixed in the third chamber and the mixture exits from the outflow of the third chamber.
5. The article of manufacture of any one of claims 1-4 wherein the vinyl polymer
- 20 is selected from the group consisting of polyvinyl alcohol, polyvinyl acetate, polyvinyl pyrrolidone and mixtures thereof.
6. The article of manufacture of any one of claims 1-4 wherein the vinyl polymer is highly hydrolyzed polyvinyl alcohol of about 50 kg/mol to about 300 kg/mol molecular weight.
- 25 7. The article of manufacture of any one of claims 1-4 wherein the vinyl polymer is highly hydrolyzed polyvinyl alcohol of about 100 kg/mol molecular weight.

8. The article of manufacture of any one of claims 1-4 wherein the vinyl polymer solution is about 1 - 50 weight percent polyvinyl alcohol based on the weight of the solution.
9. The article of manufacture of any one of claims 1-4 wherein the vinyl polymer solution is about 10 - 20 weight percent polyvinyl alcohol based on the weight of the solution.
10. The article of manufacture of any one of claims 1-4 wherein the gellant is active when contacted with the vinyl polymer solution.
11. The article of manufacture of any one of claims 1-4 wherein the gellant is inactive when contacted with the vinyl polymer solution.
12. The article of manufacture of claim 2 or 4 wherein the Flory interaction parameter of the mixture of the vinyl polymer solution and the gellant ranges from 0.25 to 1.0.
13. The article of manufacture of claim 2 or 4 wherein the Flory interaction parameter of the mixture of the vinyl polymer solution and the gellant is about 0.25 to about 0.5.
14. The article of manufacture of claim 2 or 4 wherein the Flory interaction parameter of the mixture of the vinyl polymer solution and the gellant is at least about 0.5.
15. The article of manufacture of any one of claims 1-4 wherein the first solvent is selected from the group consisting of deionized water, dimethyl sulfoxide, an aqueous solution of a C₁ to C₆ alcohol and mixtures thereof.

16. The article of manufacture of any one of claims 1-4 wherein the gellant is selected from the group consisting of salts, alcohols, polyols, polyethers, amino acids, sugars, proteins, polysaccharides, aqueous solutions thereof, and mixtures thereof.
- 5 17. The article of manufacture of any one of claims 1-4 wherein the gellant is selected from the group consisting of chondroitin sulfate, dermatan sulfate, hyaluronic acid, heparin sulfate and mixtures thereof.
18. The article of manufacture of any one of claims 1-4 wherein the gellant is selected from the group consisting of biglycan, syndecan, keratocan, decorin,
10 aggrecan and mixtures thereof.
19. The article of manufacture of claim 16 wherein the gellant is an alkali metal salt.
20. The article of manufacture of claim 19 wherein the alkali metal salt is sodium chloride.
- 15 21. The article of manufacture of claim 20 wherein the gellant is an aqueous solution of sodium chloride from about 1.5 molar to about 6.0 molar.
22. The article of manufacture of claim 16 wherein the gellant is an aqueous solution of an alcohol chosen from the groups consisting of methanol, ethanol, i-propanol, t-propanol, t-butanol and mixtures thereof.
- 20 23. The article of manufacture of claim 16 wherein the gellant is a polyether.
24. The article of manufacture of claim 23 wherein the gellant is a polyethylene glycol having an average molecular weight of about 100 – 20,000 Da and mixtures thereof.

25. The article of manufacture of claim 23 wherein the gellant is a polyethylene glycol selected from the group consisting of PEG 100, PEG 200, PEG 400, PEG 600, PEG 1000, PEG 1500, PEG 20000 and mixtures thereof.
26. The article of manufacture of any one of claims 1-4 wherein vinyl polymer
5 further comprises a radiopaque substance.
27. A dispenser adapted to receive the article of manufacture of any one of claims 1-4.
28. The dispenser of claim 27 further adapted to heat the article of manufacture of any one of claims 1-4.
- 10 29. A method of forming a hydrogel component comprising the steps of:
providing a hydrolyzed vinyl polymer dissolved in a first solvent;
providing an active gellant;
mixing the active gellant with the hydrolyzed vinyl polymer solution; and
allowing the mixture to form a hydrogel.
- 15 30. The method of claim 29 further comprising the steps of:
heating the hydrogel to a temperature above the melting point of
crosslinks in the hydrogel to form a viscoelastic polymer solution;
delivering the viscoelastic polymer solution into an at least partially
enclosed space and
20 allowing the delivered mixture to gel to form a hydrogel within the
space.
31. The method of claim 30 wherein the step of heating the hydrogel is performed
by conduction by direct or indirect contact with a heat source.
32. The method of claim 30 wherein the step of heating the hydrogel is performed
25 by absorption by the hydrogel of infrared or microwave radiation.

33. The method of claim 30 wherein the viscoelastic polymer solution is delivered at a temperature of no more than about 50 degrees Celsius.
34. The method of claim 30 wherein the viscoelastic polymer solution is delivered at a temperature of no more than about 40 degrees Celsius.
- 5 35. The method of claim 30 wherein the space is a body cavity of a vertebrate subject.
36. The method of claim 30 wherein the space is a mold.
37. The method of claim 30 wherein the viscoelastic polymer solution conforms to the space.
- 10 38. The method of claim 35 wherein the viscoelastic polymer solution is delivered at a temperature within a few degrees Celsius of the normal body temperature of the tissue surrounding the body cavity.
39. The method of claim 35 wherein the viscoelastic polymer solution is delivered at a temperature of about 34-40 degrees Celsius.
- 15 40. The method of claim 35 wherein the space is within an intervertebral disk.
41. The method of claim 35 wherein the space is within an articulated joint.
42. The method of claim 35 wherein the space is an actual or potential subdermal space.
43. The method of claim 29 wherein vinyl polymer further comprises a
20 radiopaque substance.

44. The method of claim 29 wherein the vinyl polymer solution contains a mixture of vinyl polymers differing in molecular weight.
45. The method of claim 30 wherein the viscoelastic polymer solution is locally chilled at the delivery entrance site to induce more rapid gelation to form a closure plug.
- 5
46. The method in claim 45 where the chilling is produced by contacting the viscoelastic polymer solution with a cooling probe.
47. The method in claim 30 wherein the walls of the enclosed space are pre-treated to induce rapid gelation of the vinyl polymer solution at the walls.
- 10
48. The method in claim 47 wherein the pre-treatment involves cooling the walls of the enclosed space with a cooling probe or by flushing with cold saline.
49. The method in claim 47 wherein the pre-treatment involves coating the interior walls of the enclosed space with the gellant.
50. The method in claim 30 wherein the liquid vinyl polymer solution in the enclosed space is locally chilled from the center after injection.
- 15
51. The method in claim 50 wherein the chilling is produced by contacting the viscoelastic polymer solution with a cooling probe.
52. The method in claim 30 wherein a barrier material is placed in the enclosed space to retard diffusion of the gellant from the hydrogel.

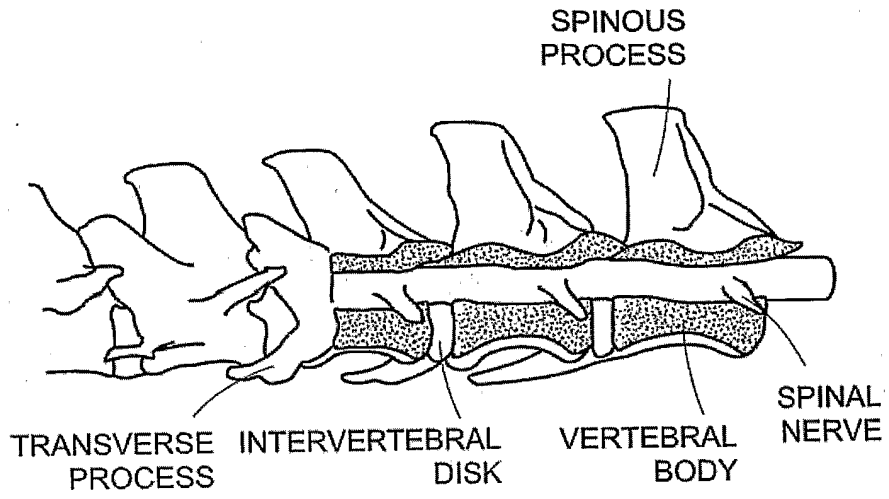

FIG. 1A

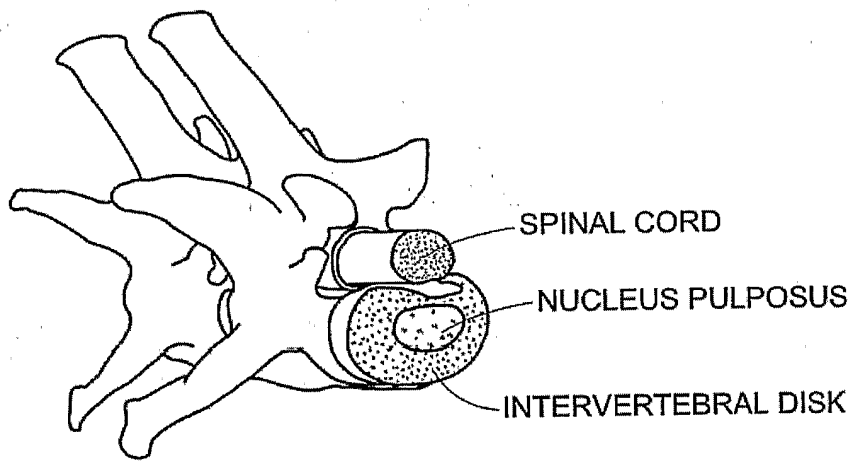

FIG. 1B

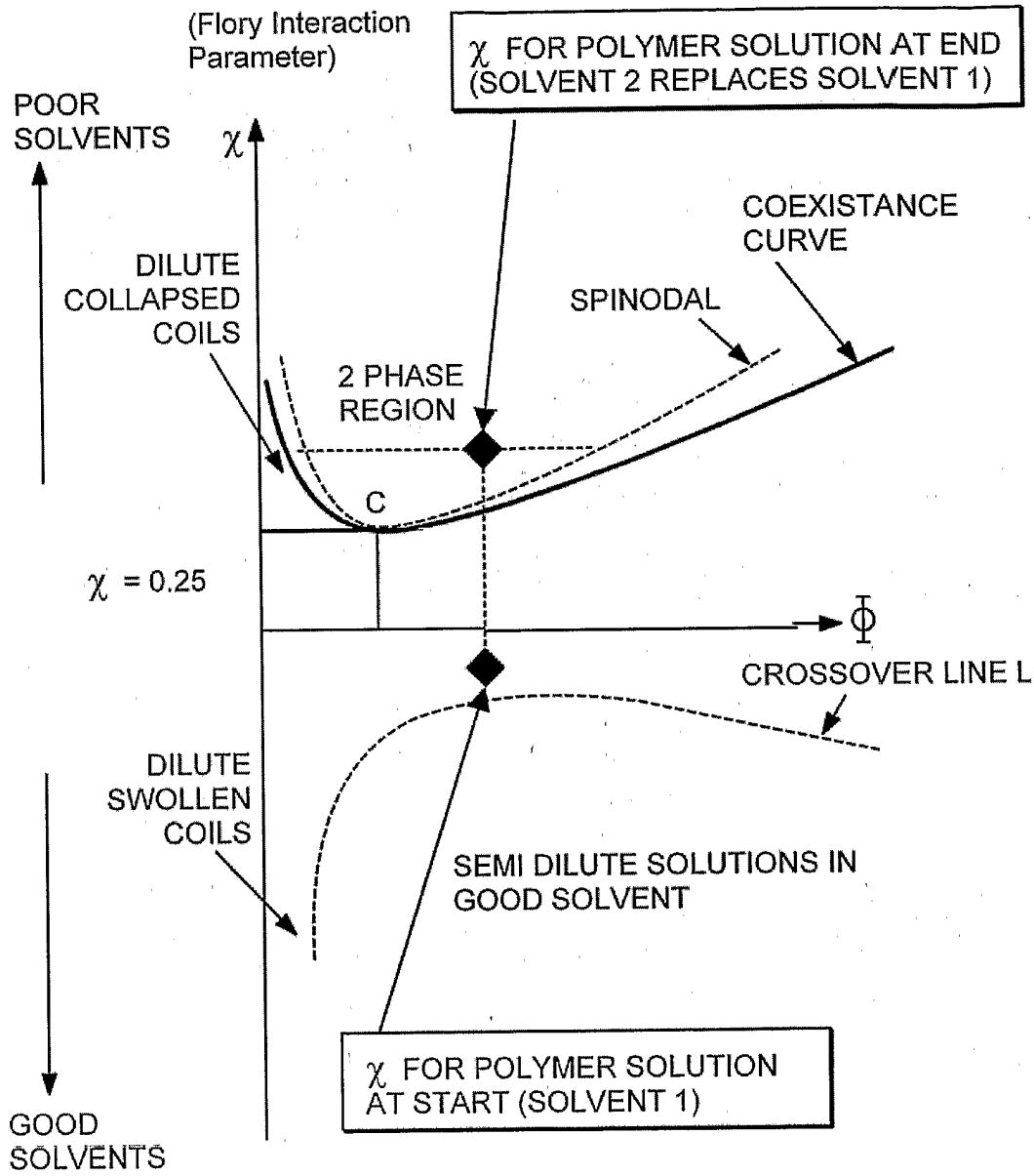

FIG. 2

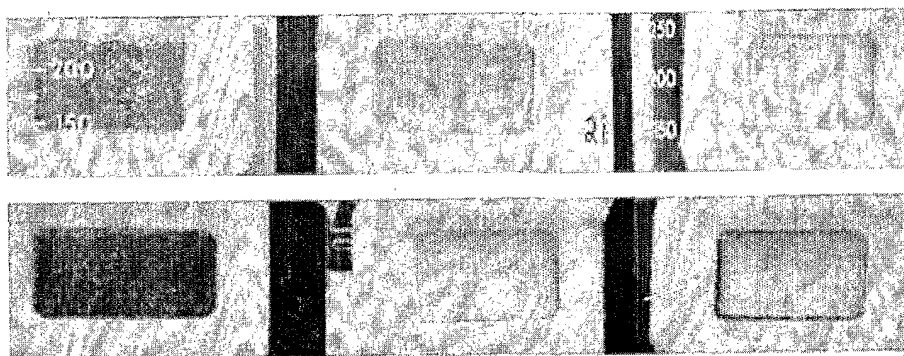

FIG. 3

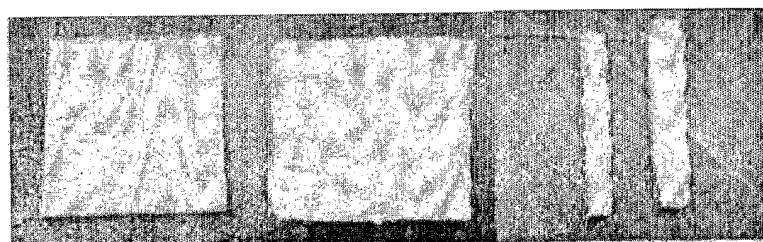

FIG. 4

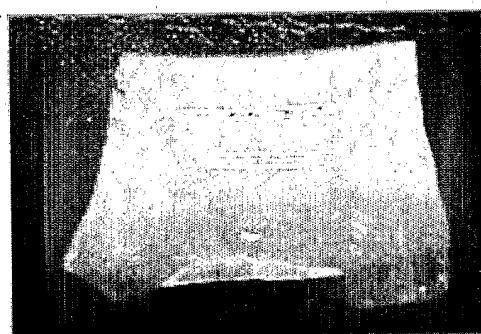

FIG. 5

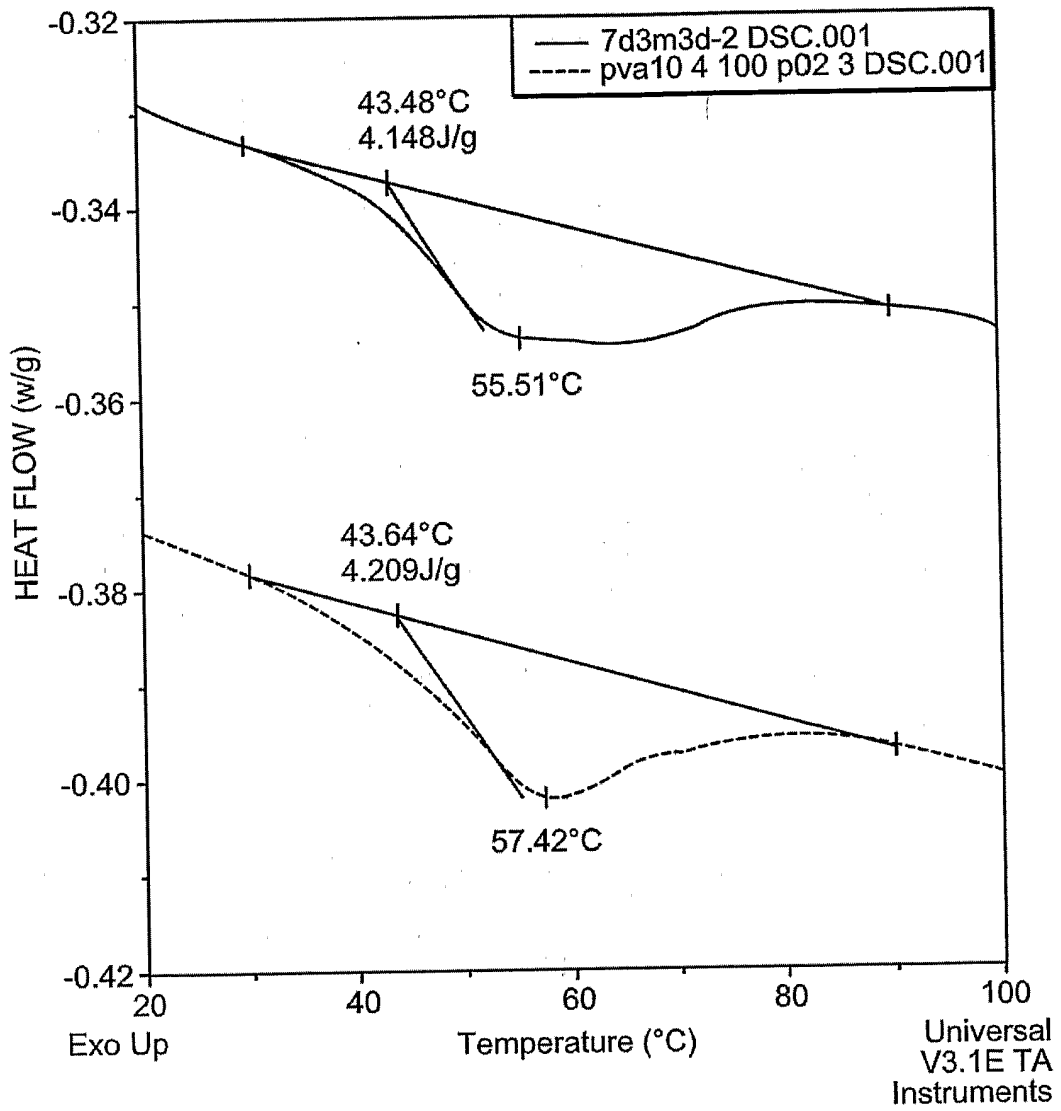

FIG. 6

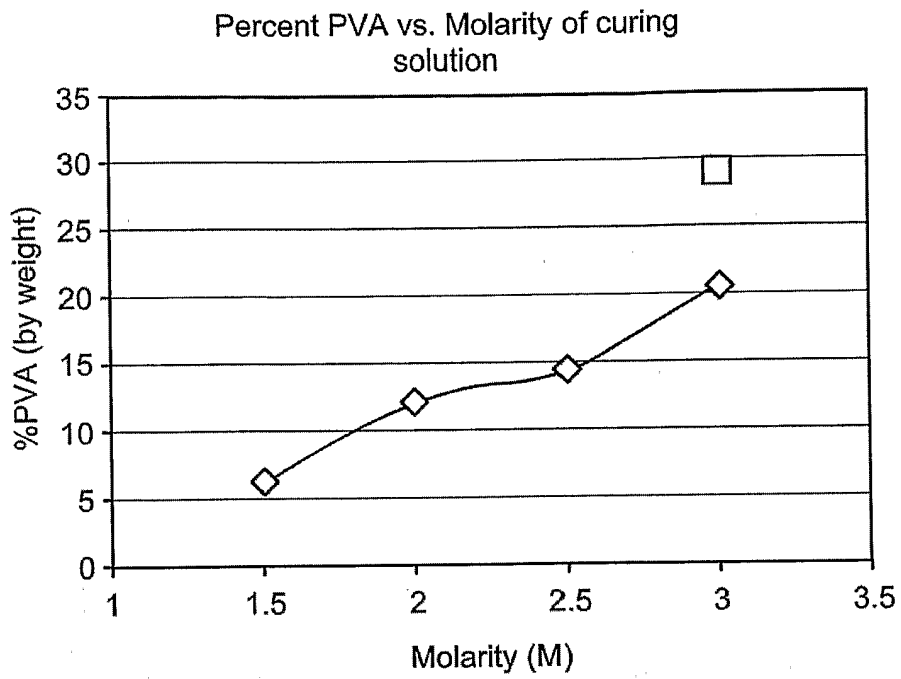

FIG. 7

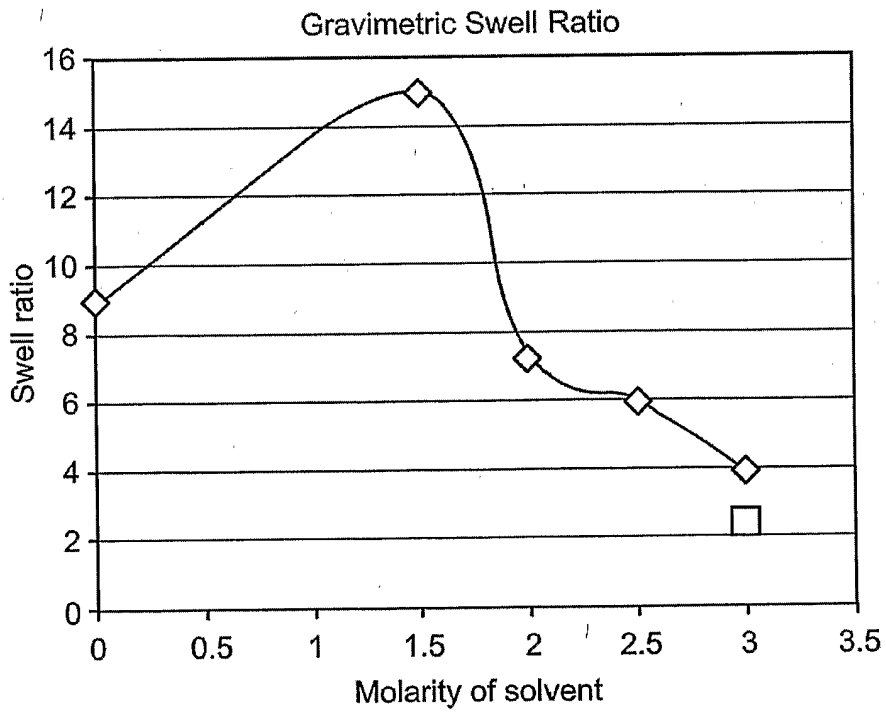

FIG. 8

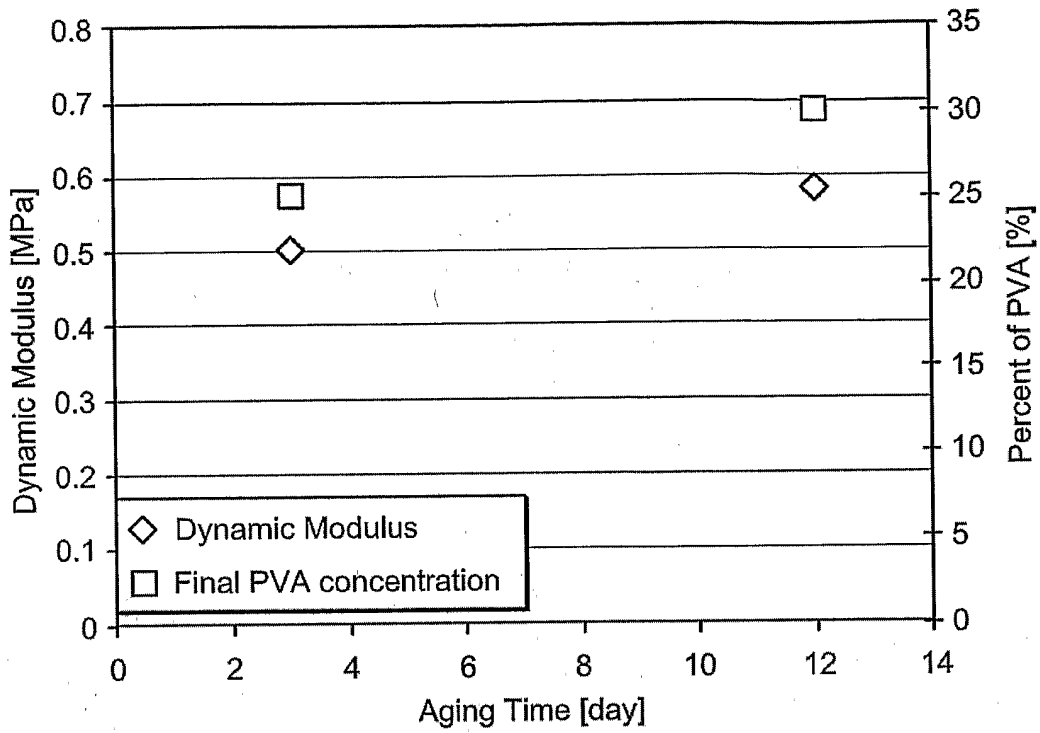

FIG. 9

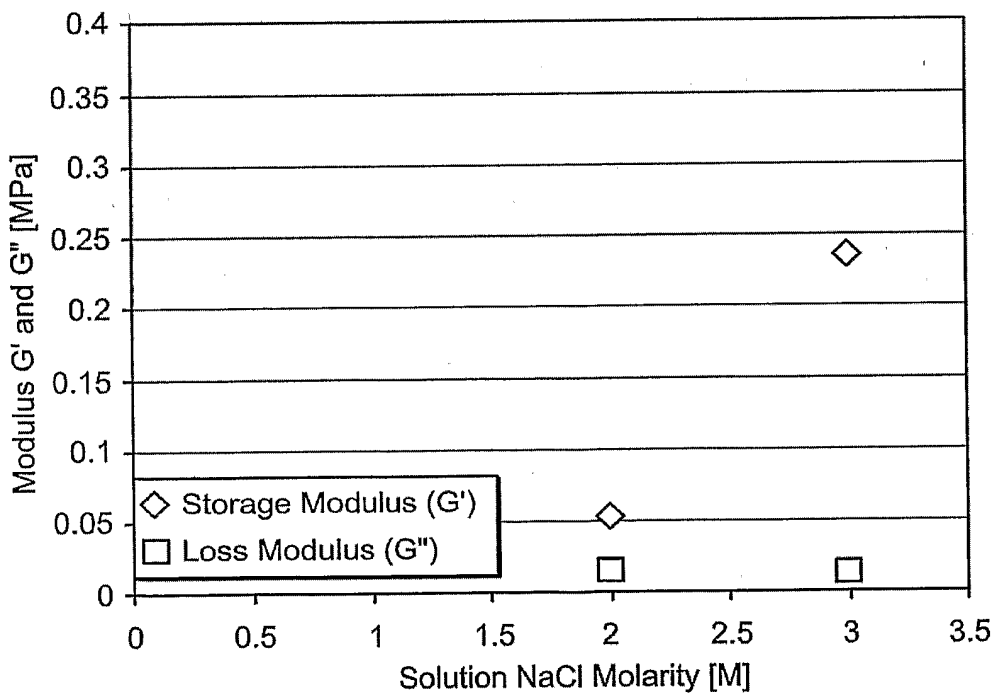

FIG. 10

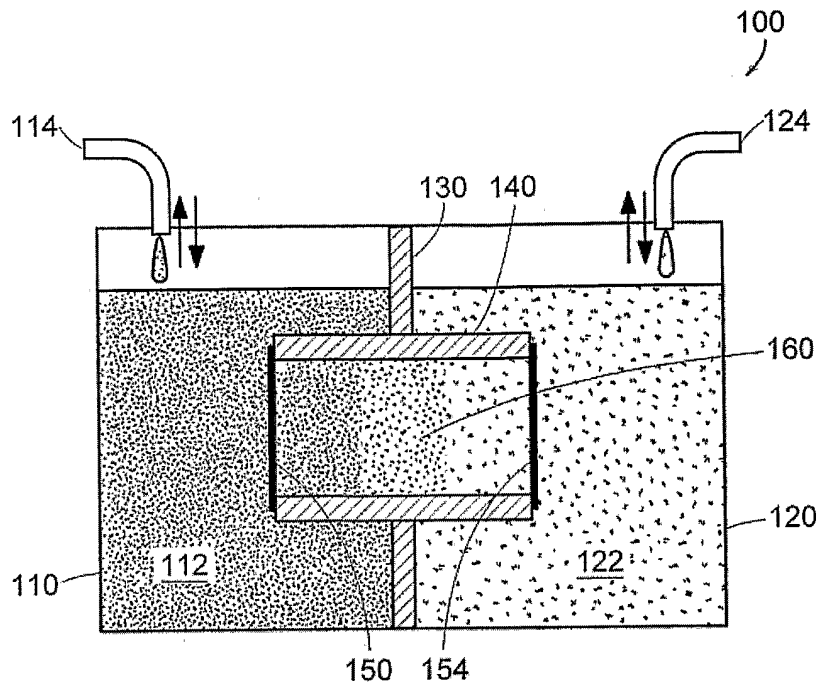

FIG. 11

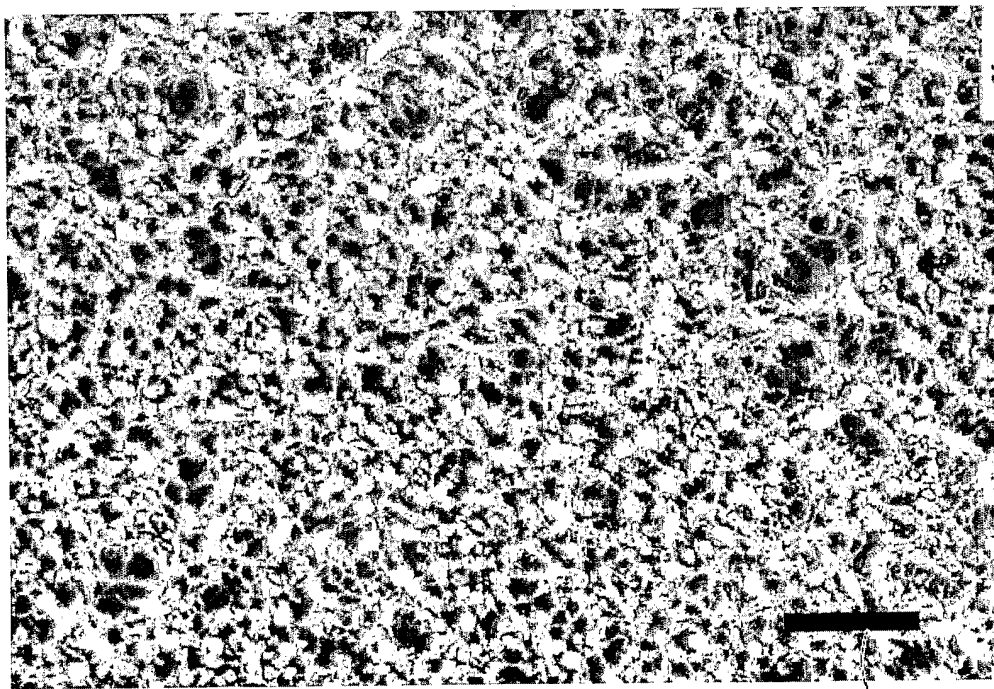

FIG. 12

100 nm

220
/

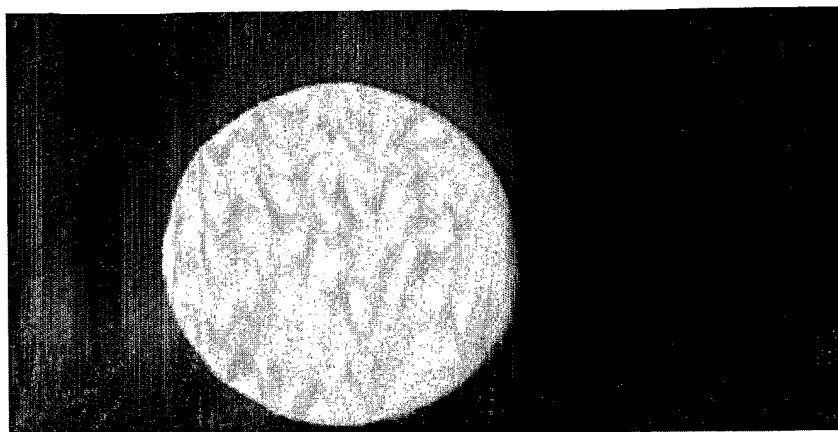

FIG. 13A

240
/

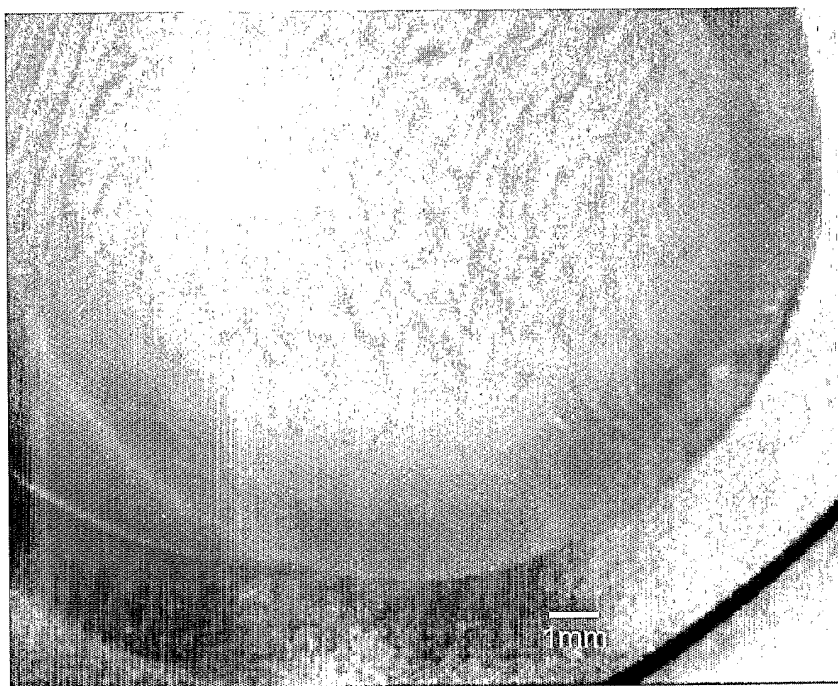

FIG. 13B

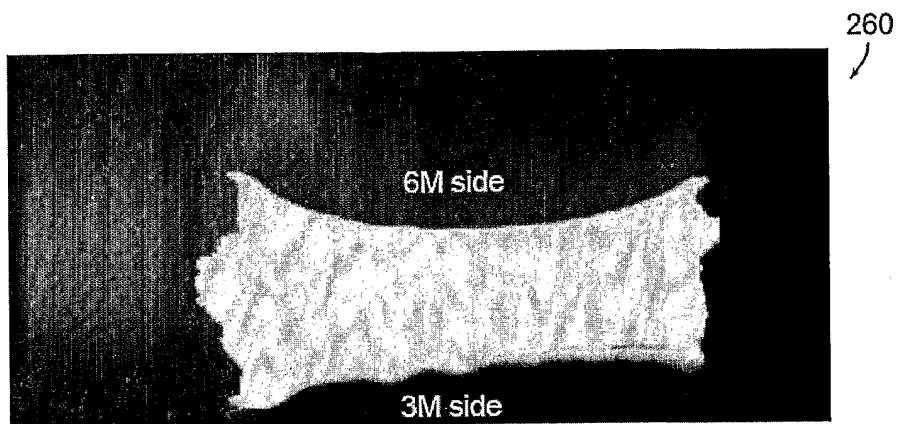

FIG. 14

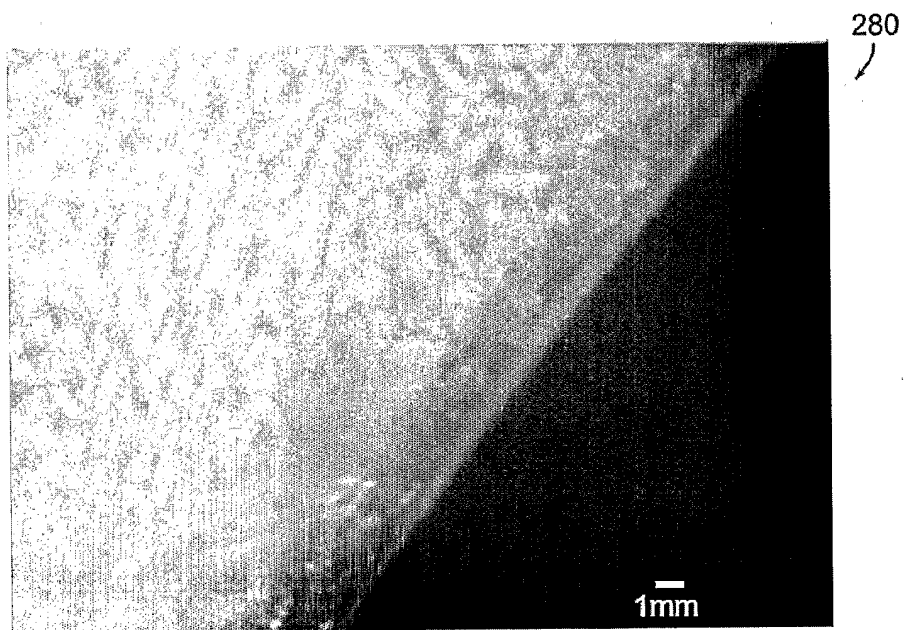
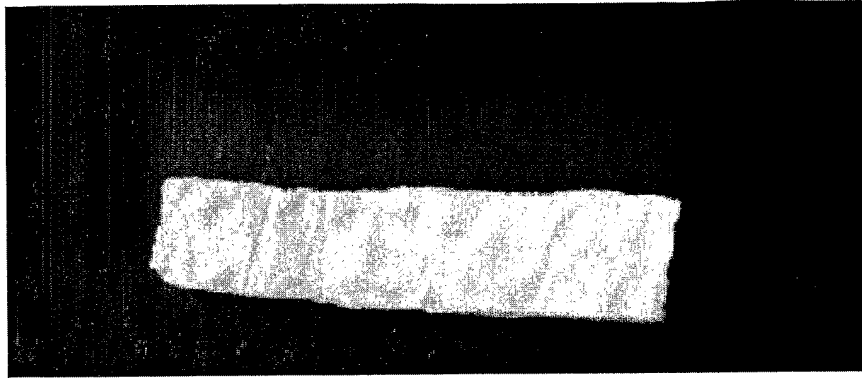
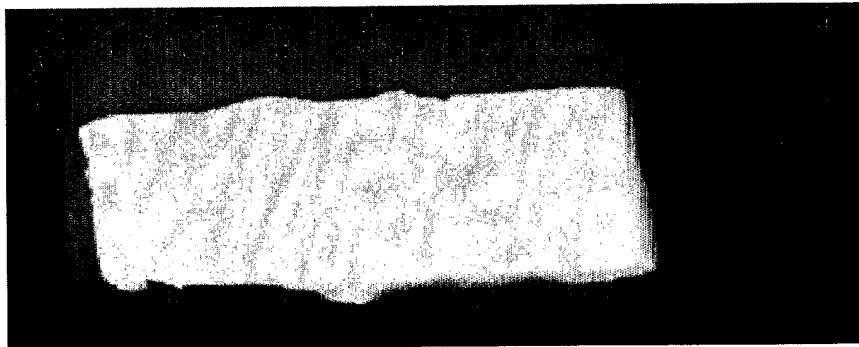

FIG. 15



290
↙

FIG. 16



300
↙

FIG. 17

301788.3002-104

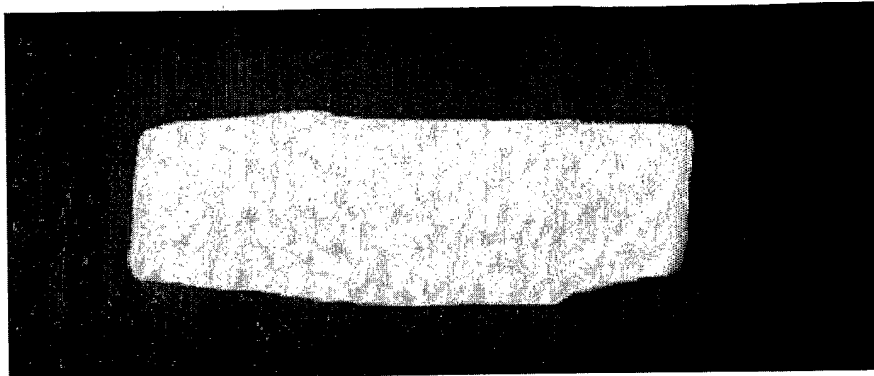

FIG. 18

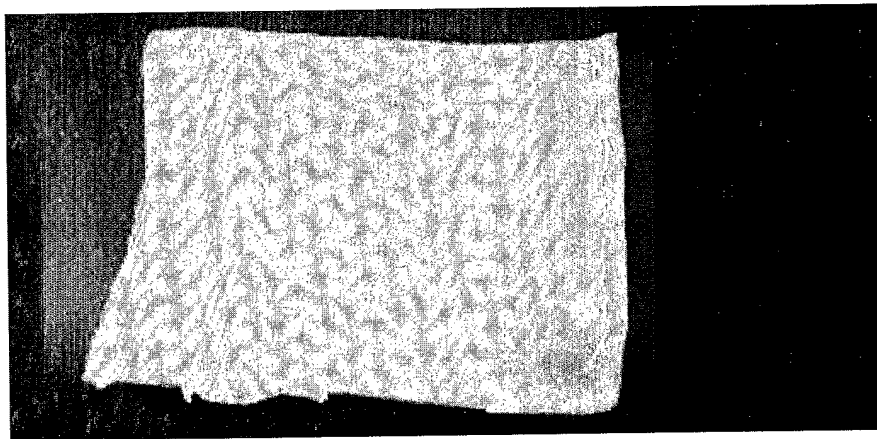

FIG. 19

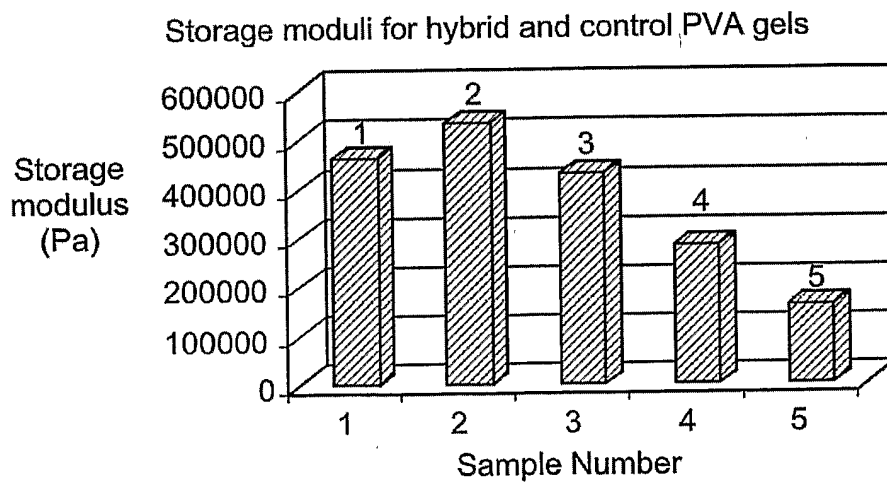

FIG. 20

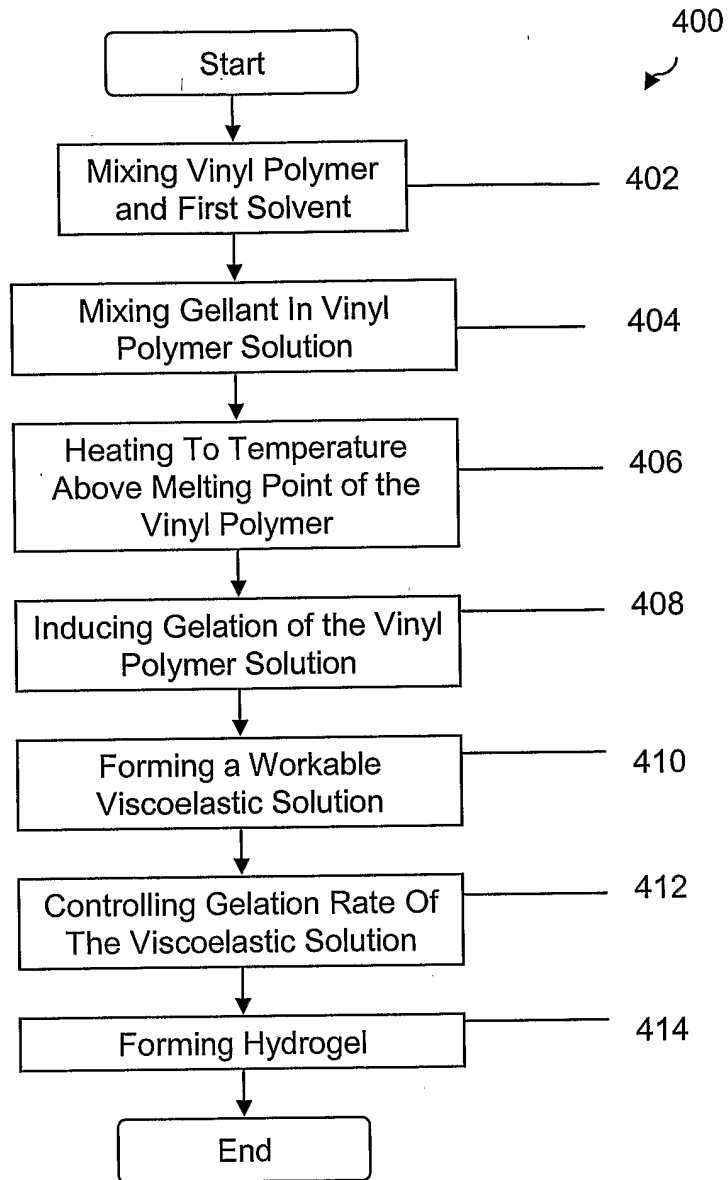

FIG. 21A

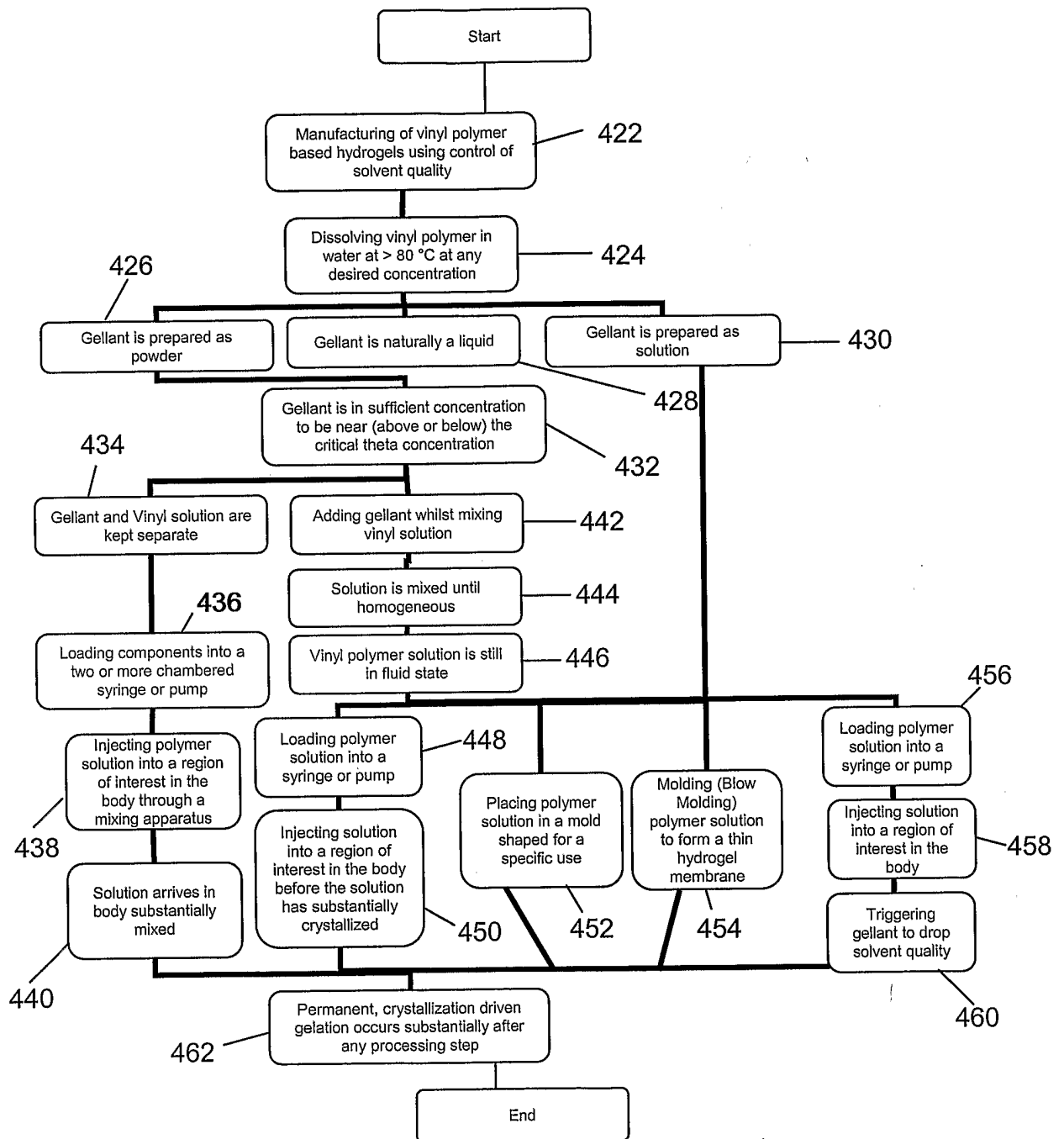

FIG. 21B

470



FIG. 22A

474

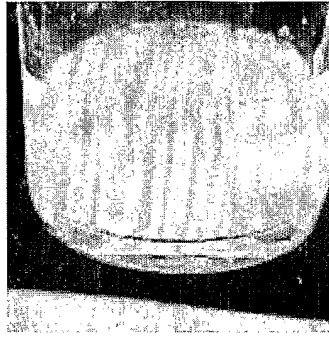

FIG. 22B

478

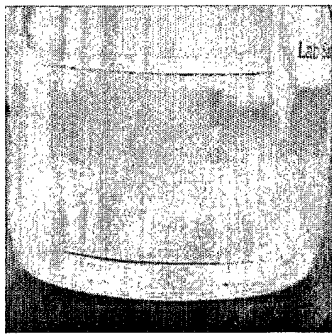

FIG. 22C

482

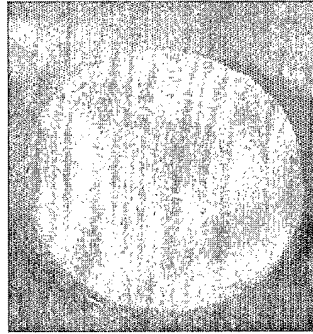

FIG. 22D

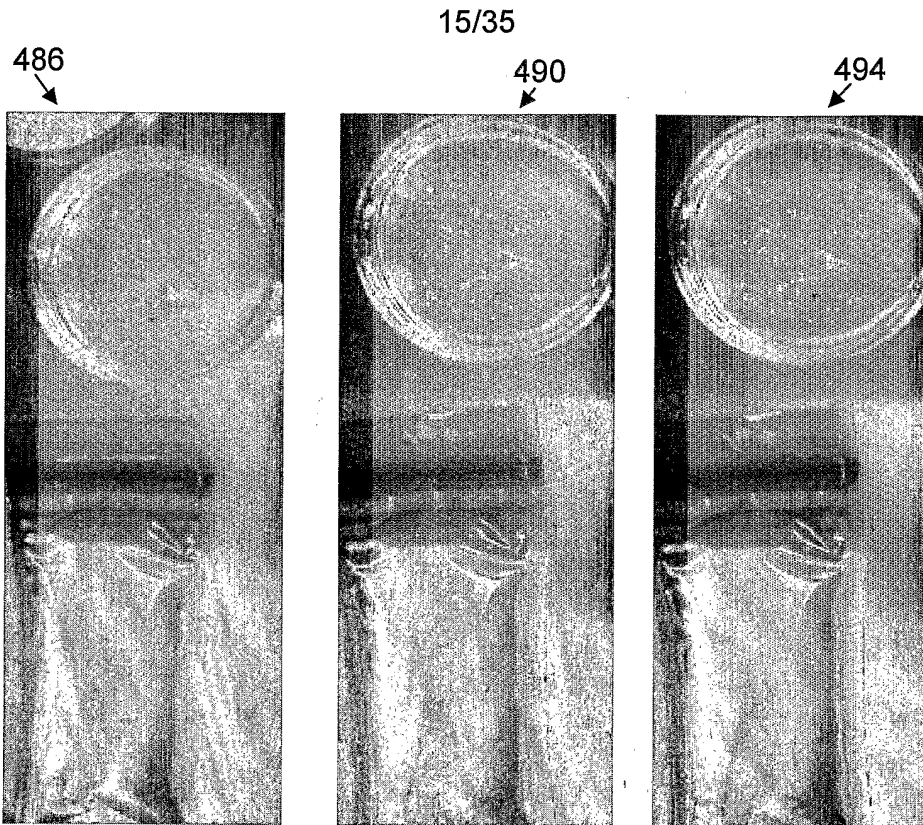

FIG. 23A

FIG. 23B

FIG. 23C

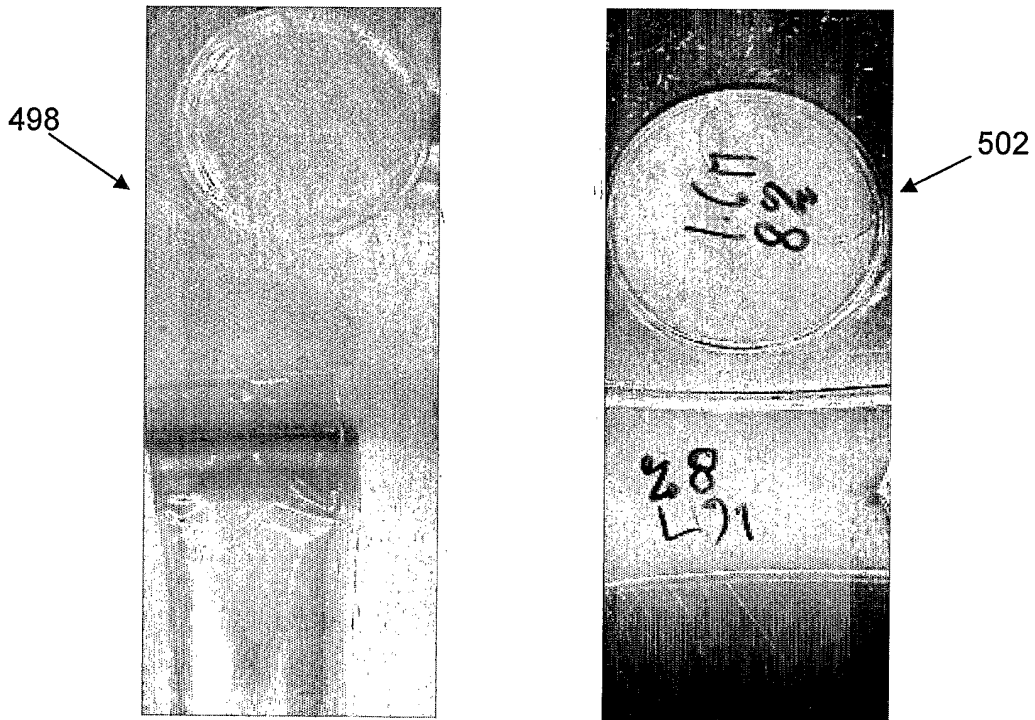

FIG. 23D

FIG. 23E

506

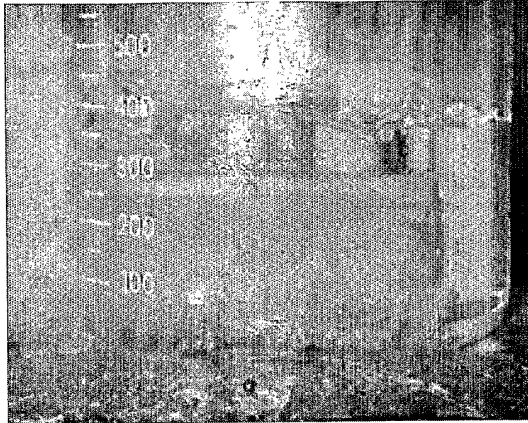

FIG. 24A

510

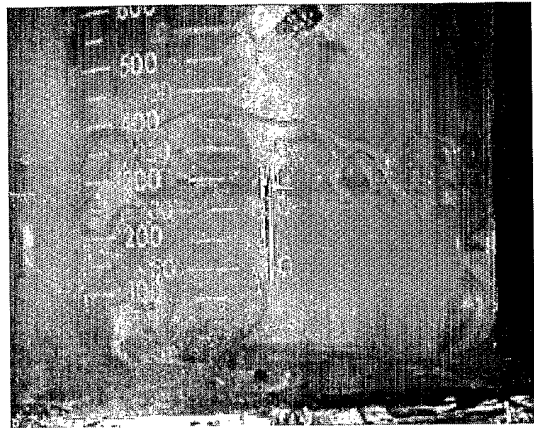

FIG. 24B

514

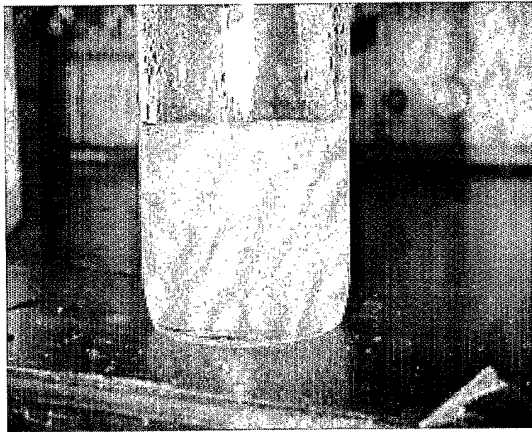

FIG. 24C

518

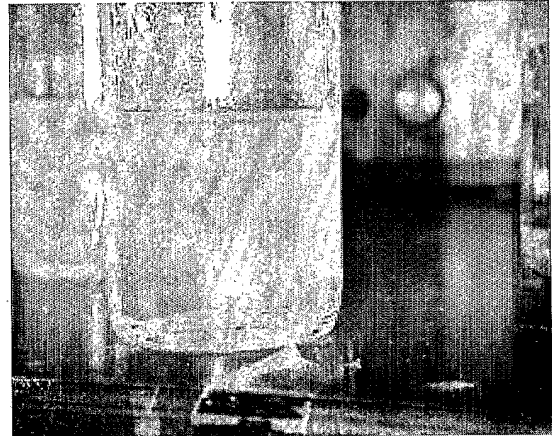

FIG. 24D

522

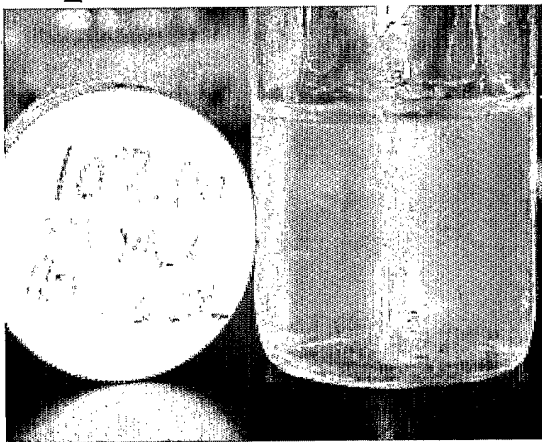

FIG. 24E

526

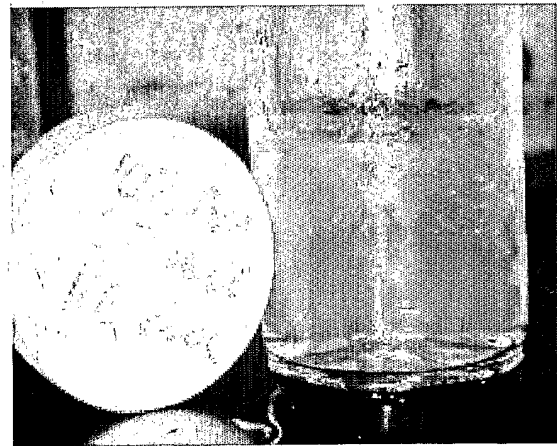

FIG. 24F

17/35

530

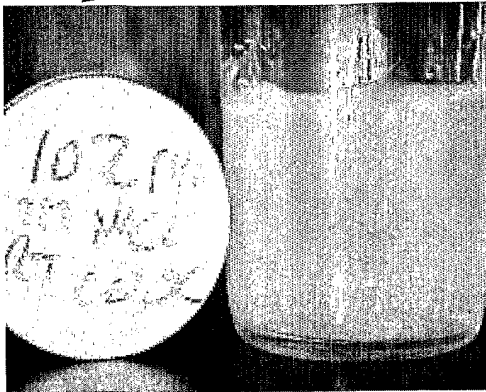

FIG. 25A

534



FIG. 25B

538



FIG. 25C

542



FIG. 25D

546

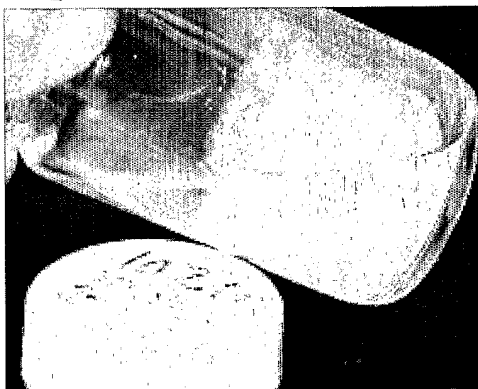

FIG. 25E

550



FIG. 25F



FIG. 26A

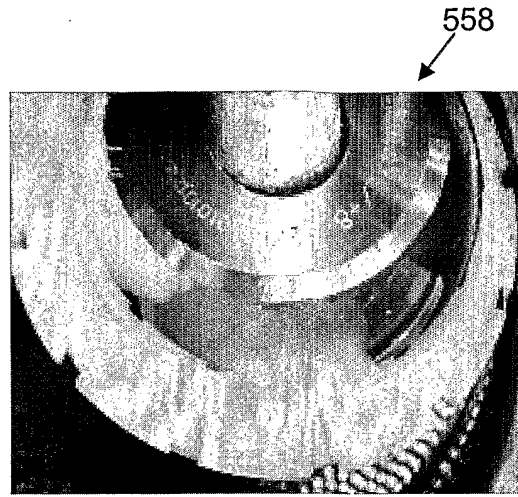

FIG. 26B

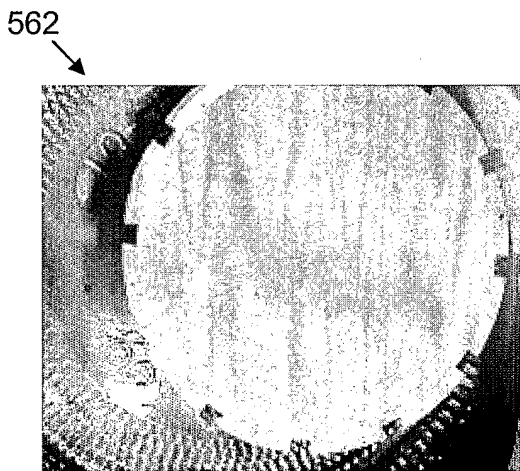

FIG. 26C

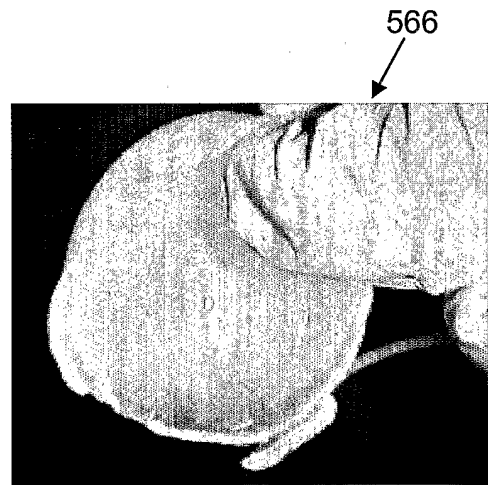

FIG. 26D

570



FIG. 27A

574

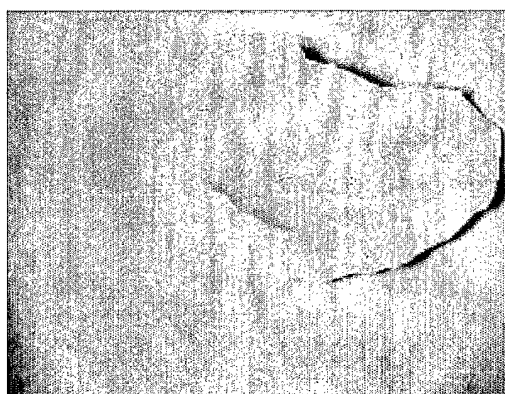

FIG. 27B

20/35

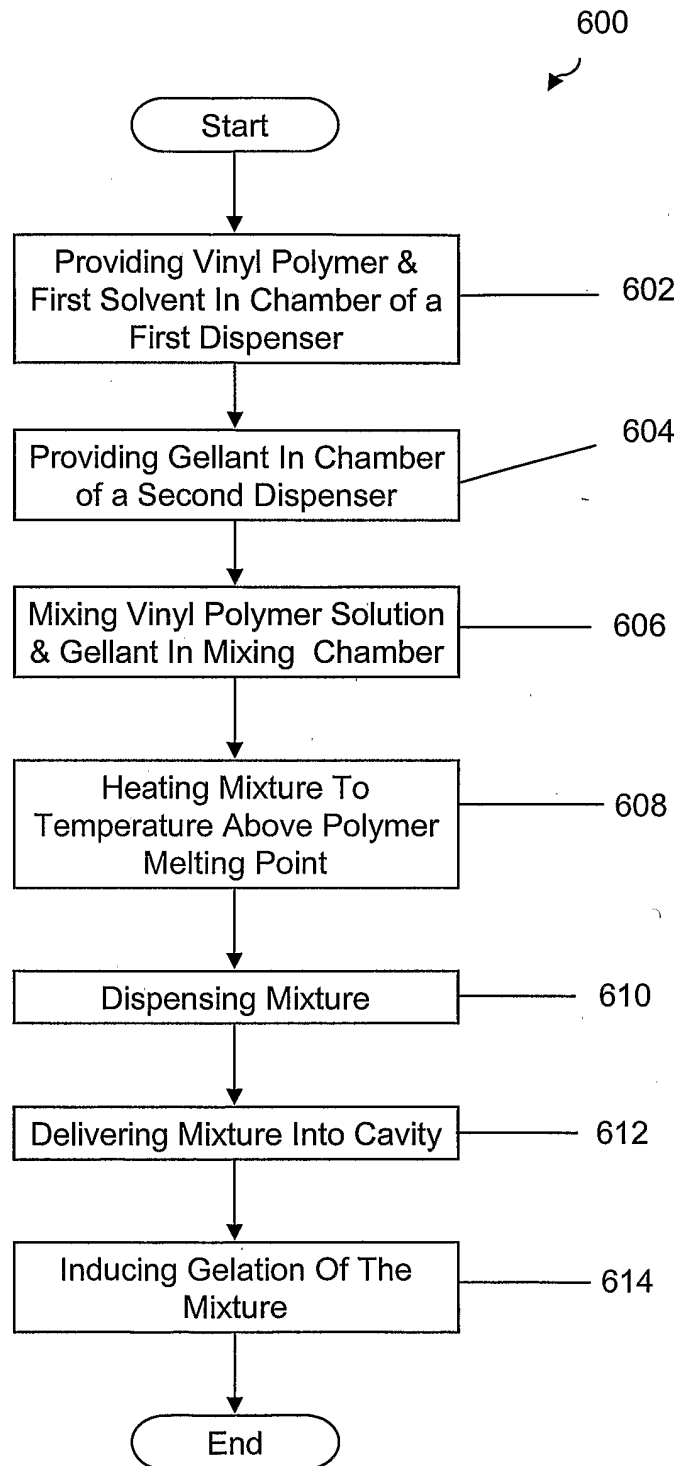

FIG. 28A

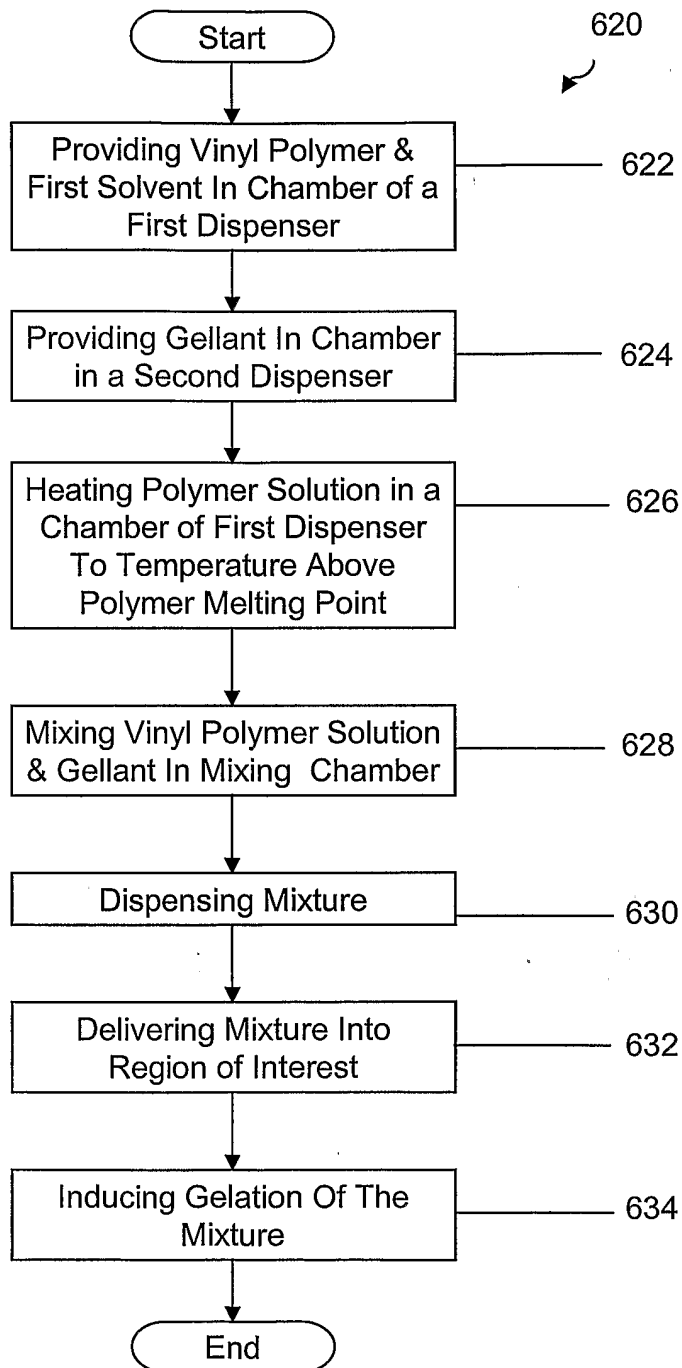

FIG. 28B

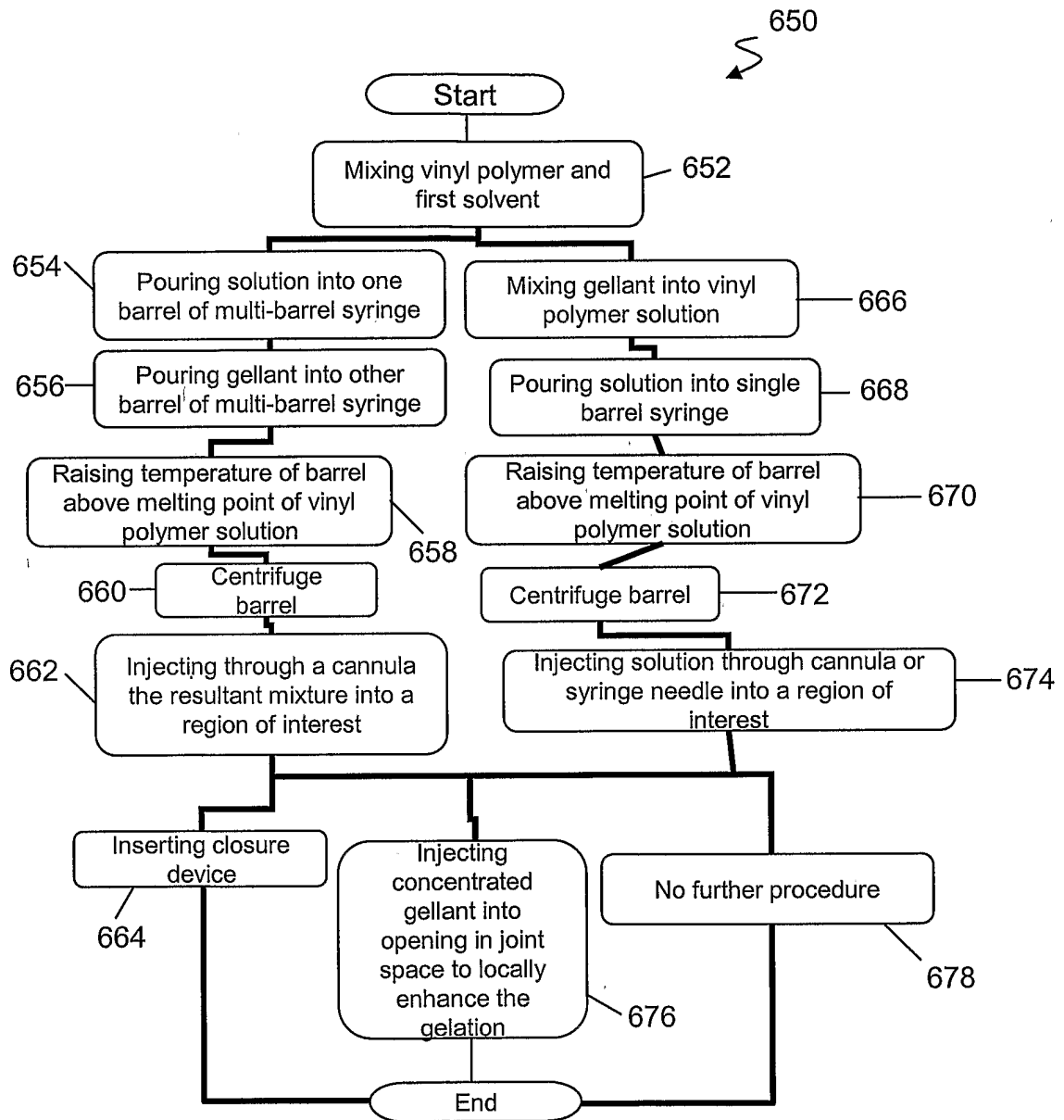
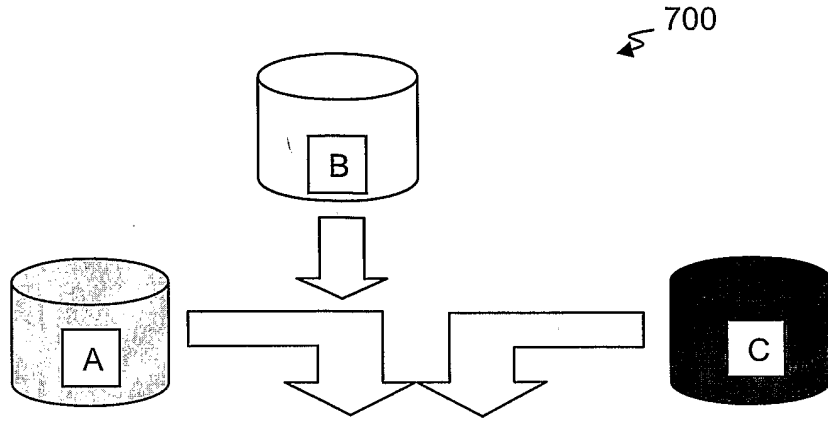
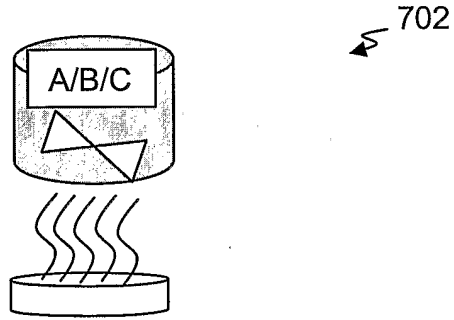

FIG. 28C



700

FIG. 29A



702

FIG. 29B

24/35

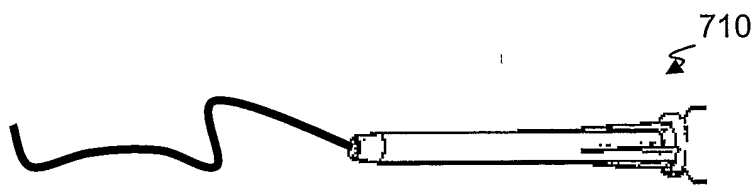
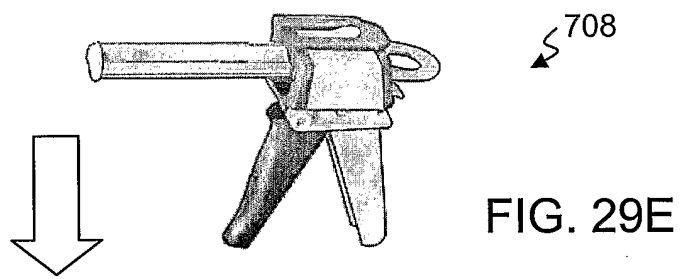
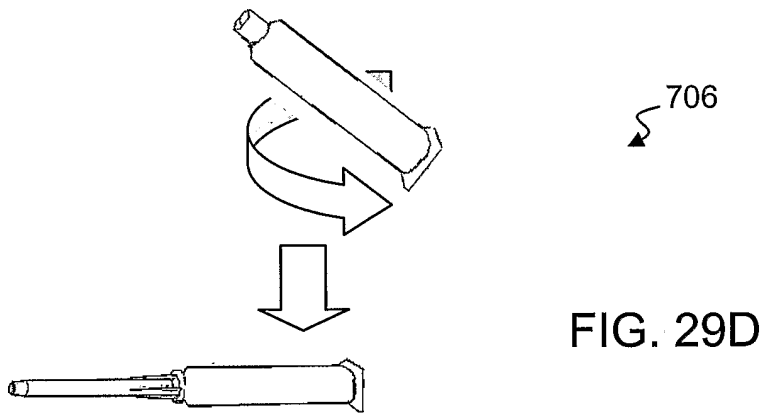
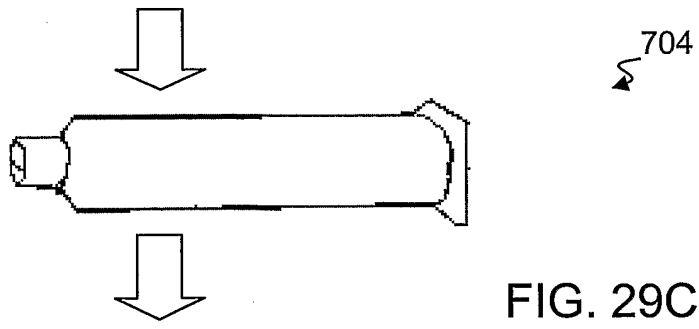

FIG. 29F

25/35

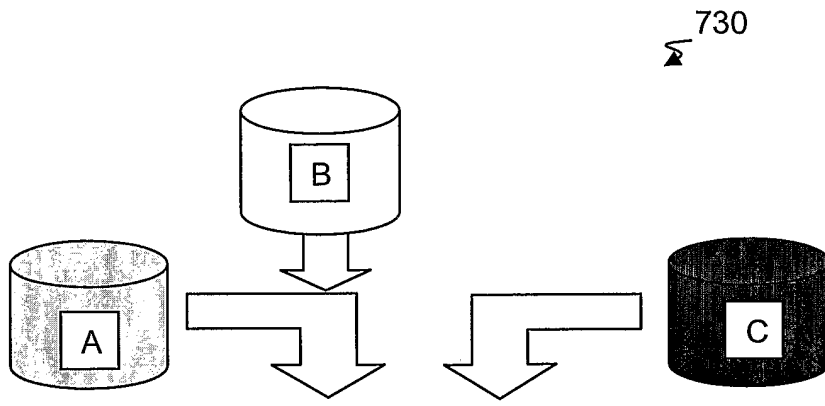

FIG. 30A

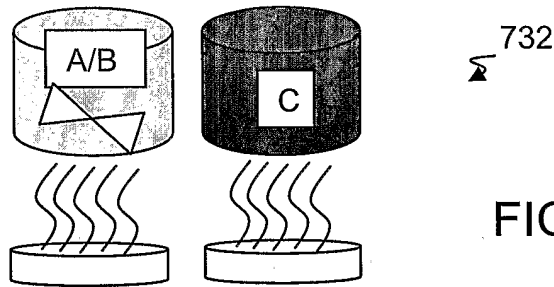

FIG. 30B

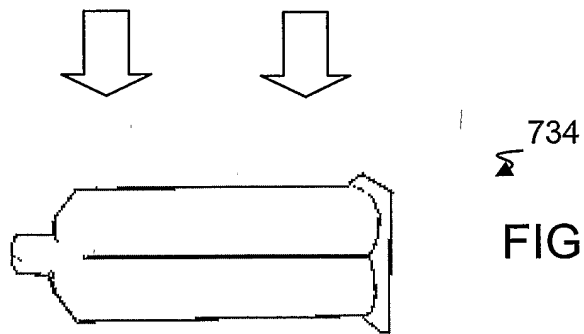
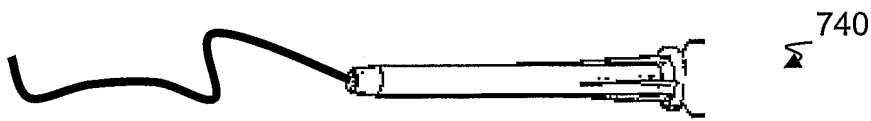
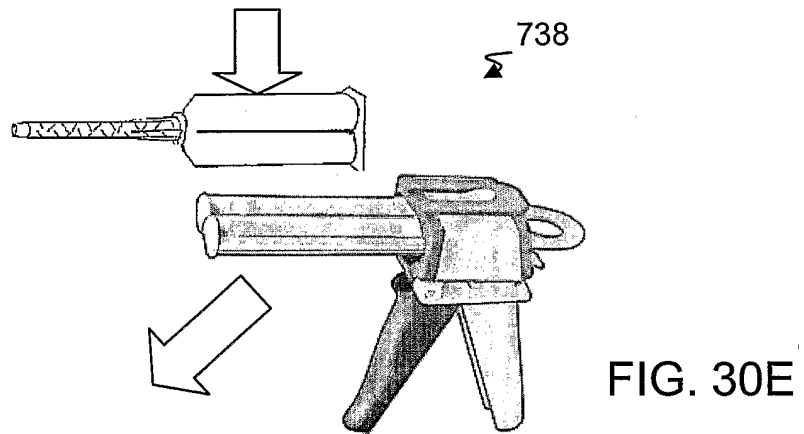
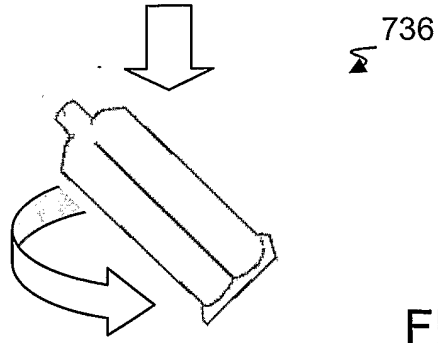

FIG. 30C

26/35



750

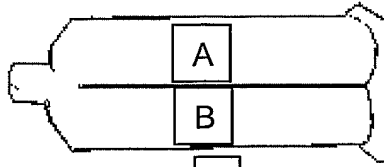
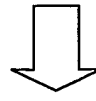

FIG. 31A



752

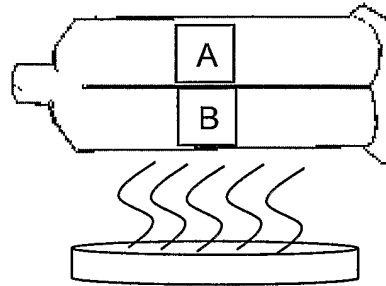
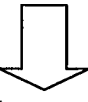

FIG. 31B



754

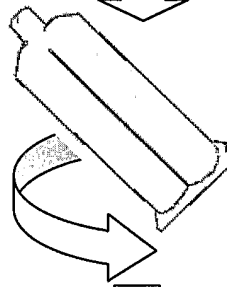

FIG. 31C



756

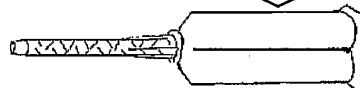

FIG. 31D

758

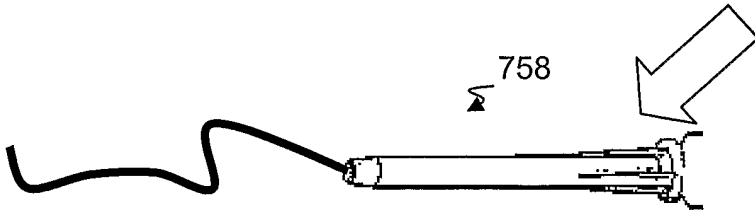

FIG. 31E

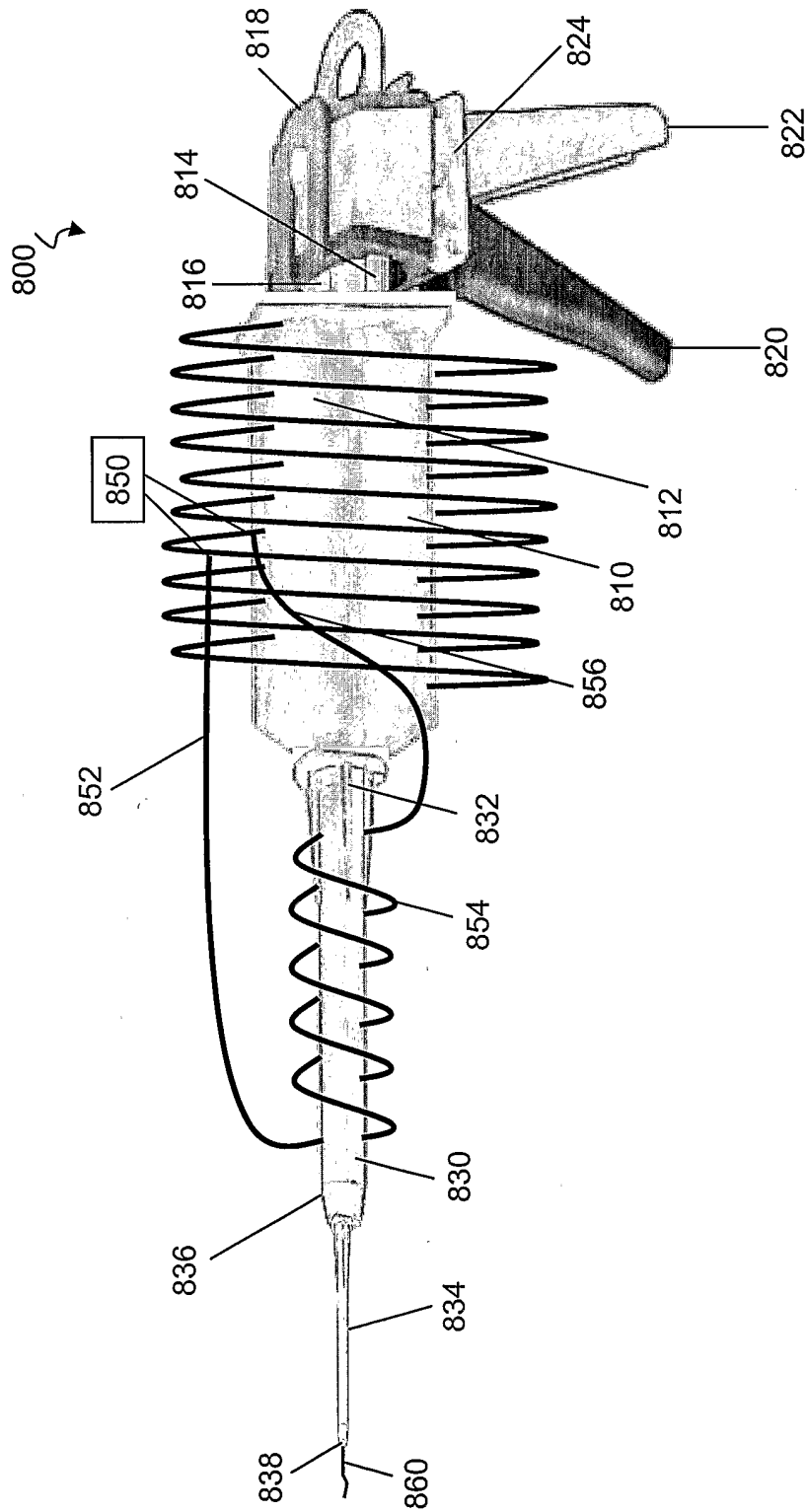

FIG. 32A

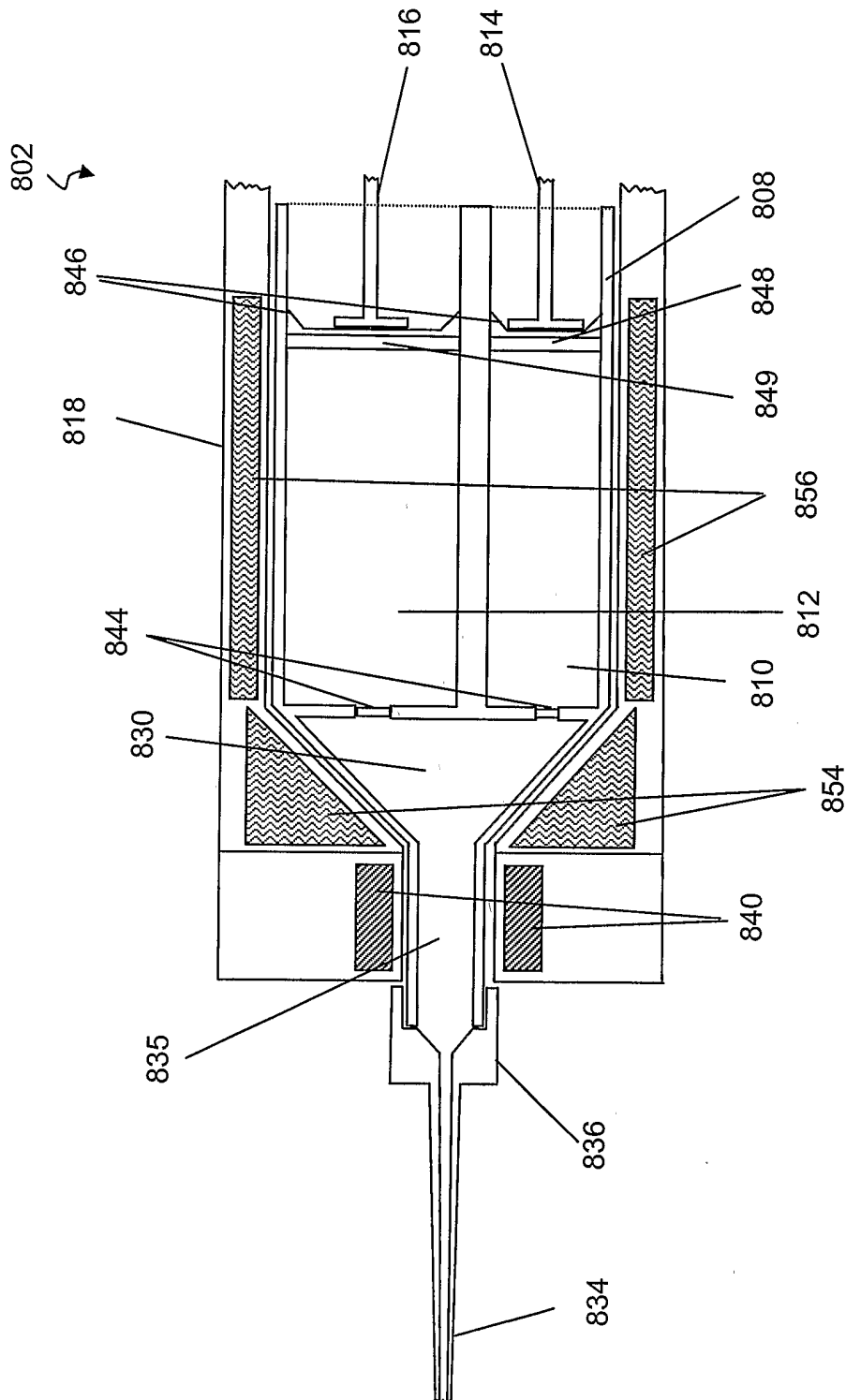

FIG. 32B

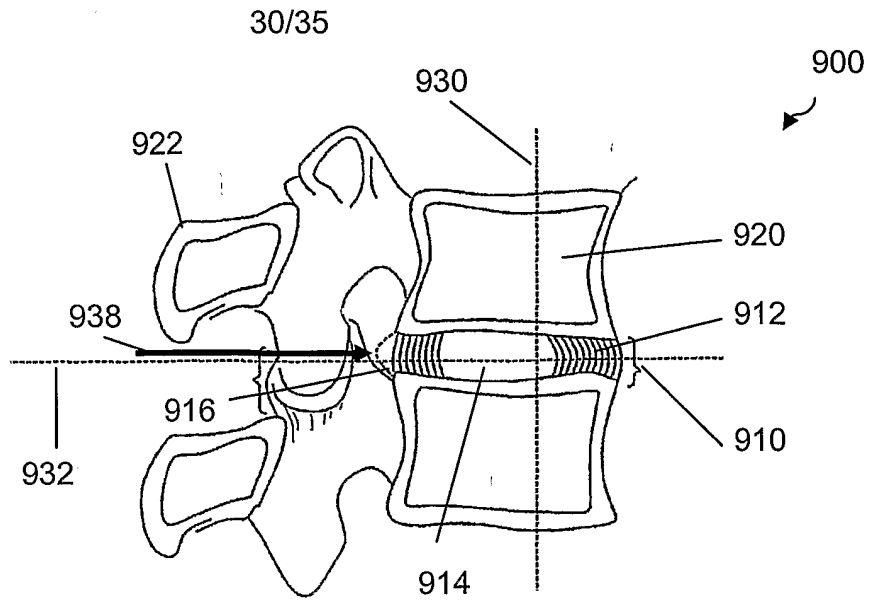

FIG. 33

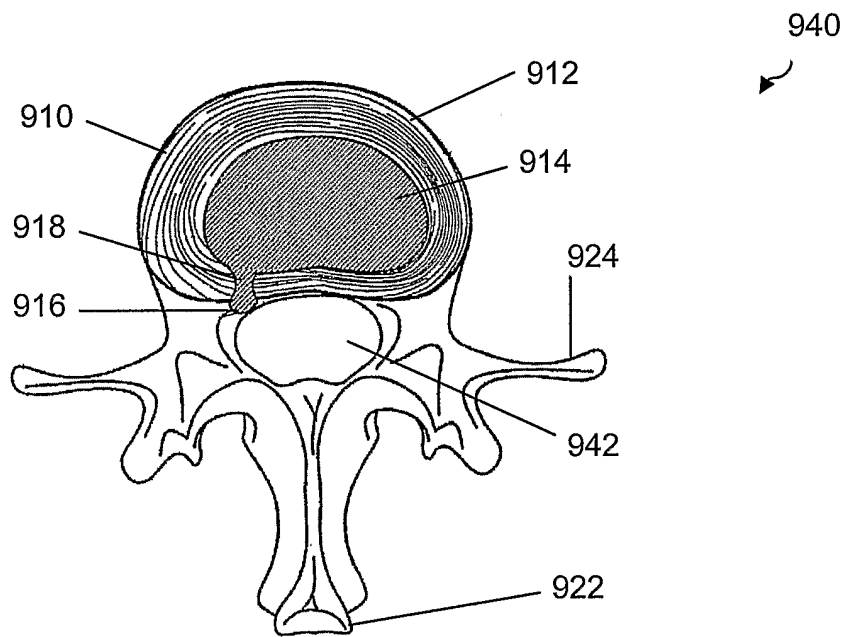

FIG. 34

31/35

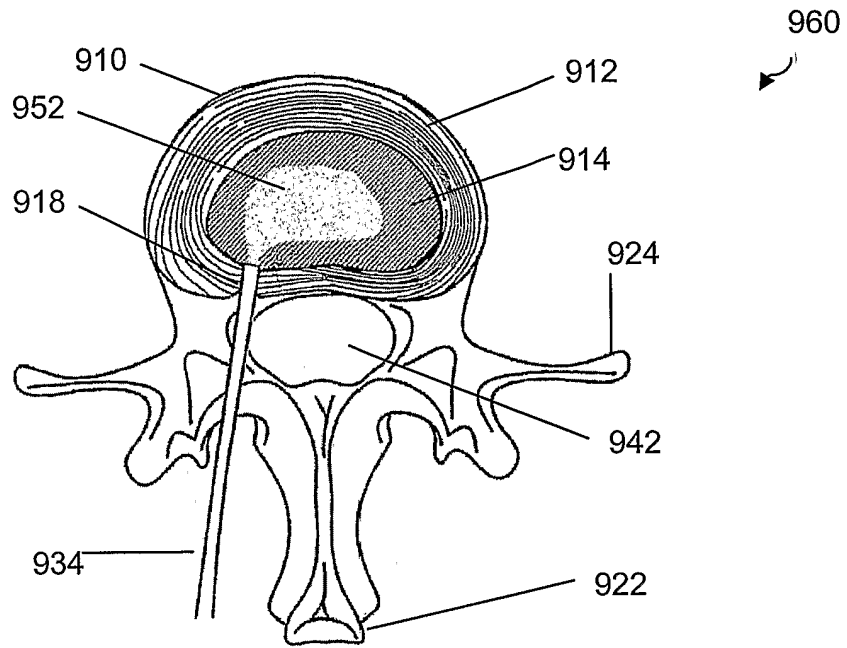

FIG. 35

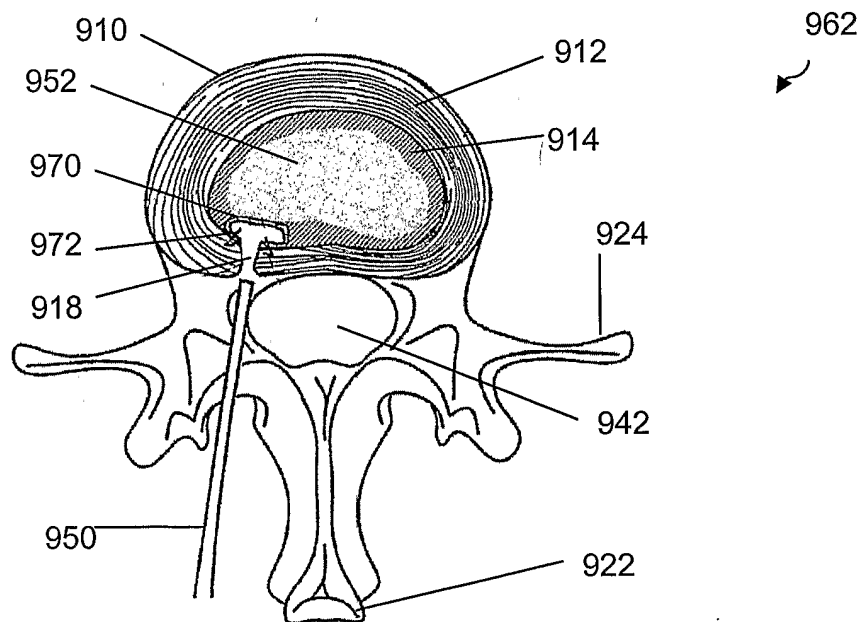

FIG. 36

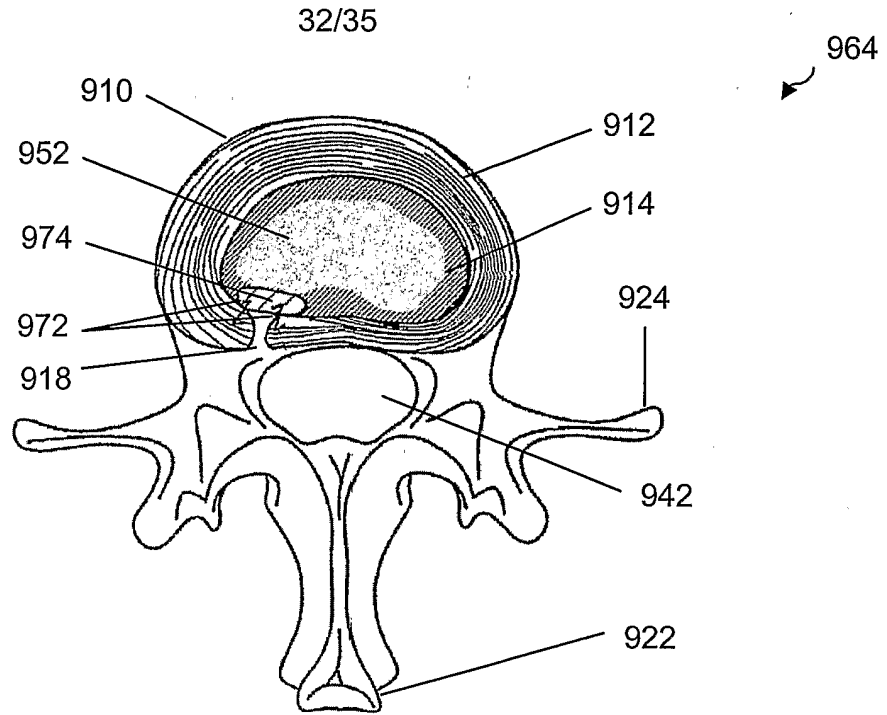

FIG. 37

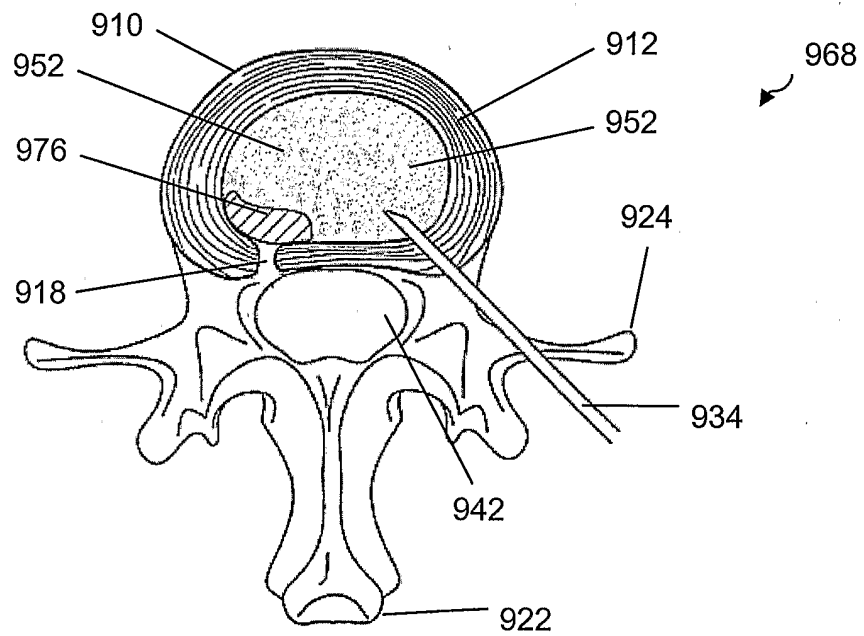

FIG. 38A

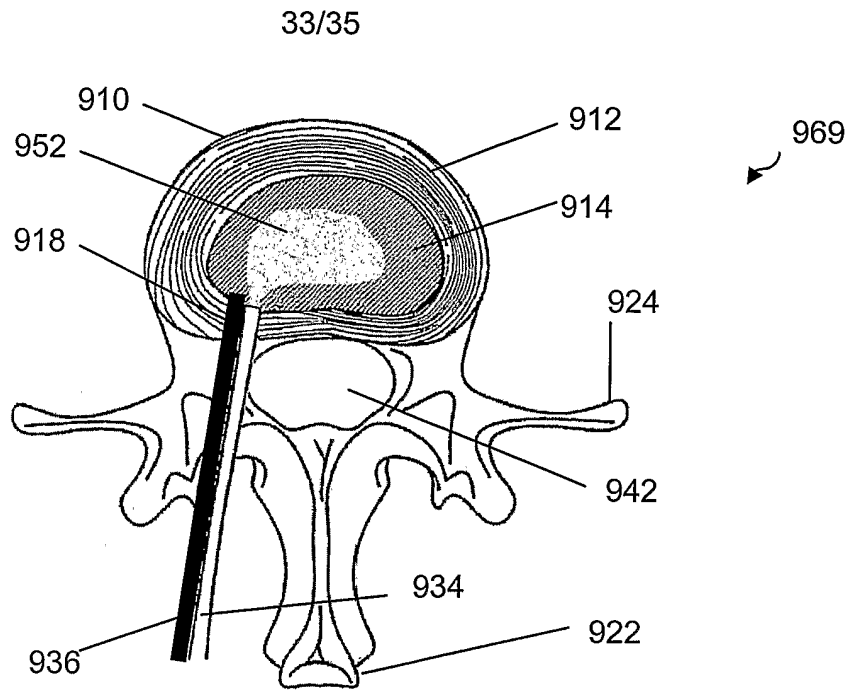

FIG. 38B

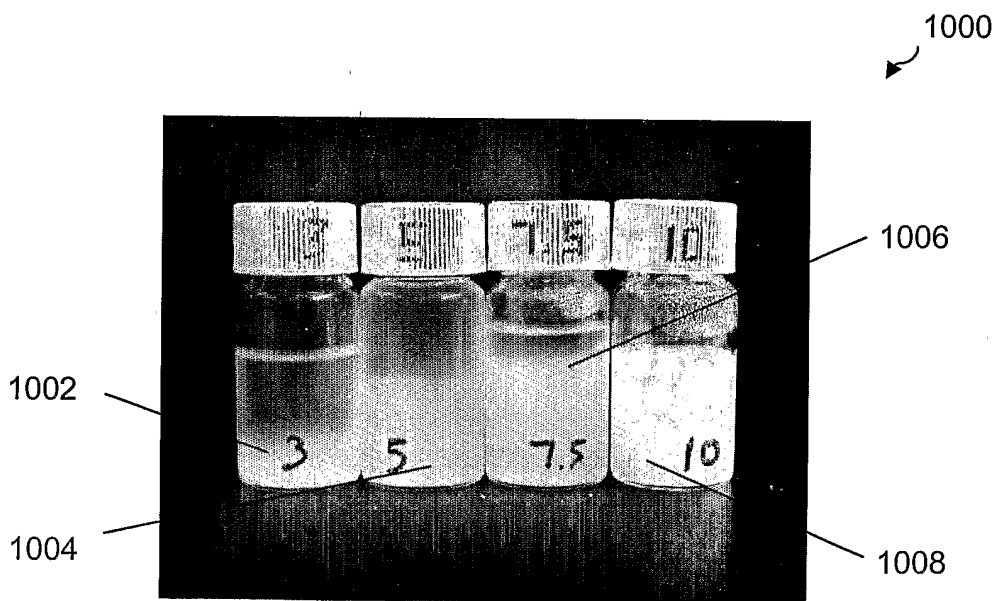

FIG. 39

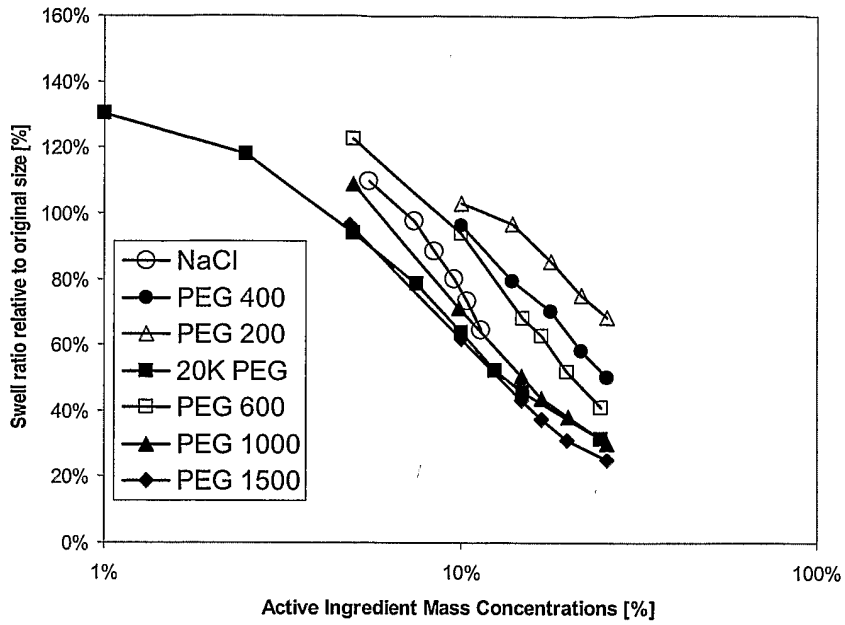

FIG. 40

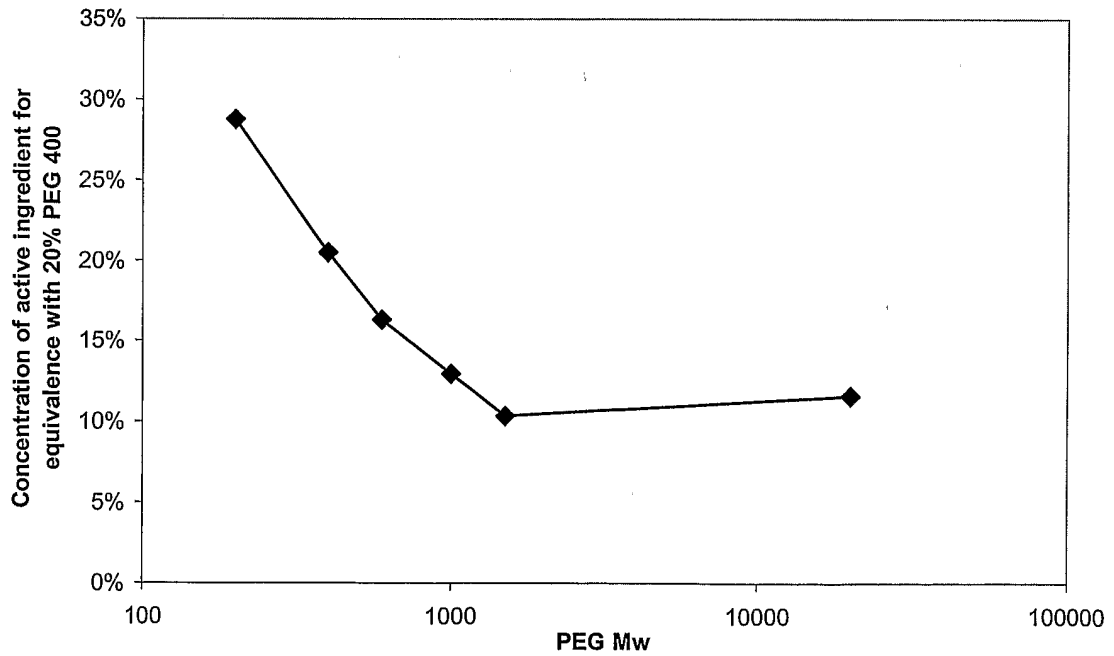

FIG. 41

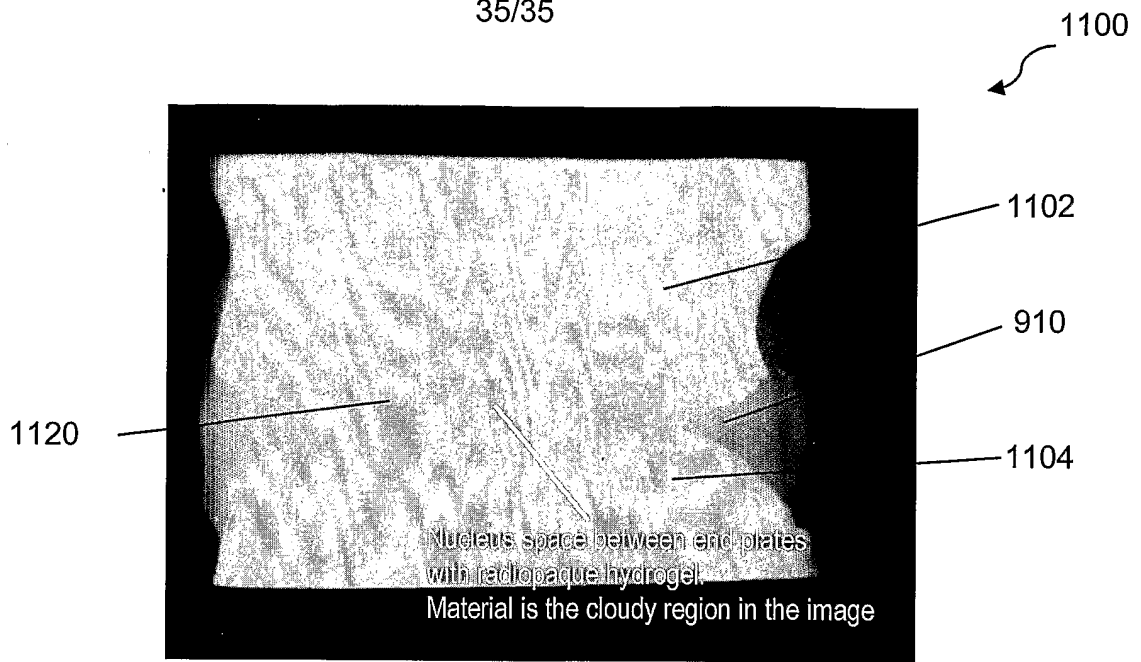

FIG. 42



FIG. 43