



## INTERNATIONAL APPLICATION PUBLISHED UNDER THE PATENT COOPERATION TREATY (PCT)

<b>(51) International Patent Classification <sup>5</sup> :</b> <b>A61F 6/14, A61M 31/00</b> <b>// A61K 9/02</b>	<b>A1</b>	<b>(11) International Publication Number:</b> <b>WO 93/00055</b> <b>(43) International Publication Date:</b> 7 January 1993 (07.01.93)
<p><b>(21) International Application Number:</b> PCT/FI92/00189</p> <p><b>(22) International Filing Date:</b> 17 June 1992 (17.06.92)</p> <p><b>(30) Priority data:</b>  913025                      20 June 1991 (20.06.91)                      FI</p> <p><b>(71) Applicant (for all designated States except US):</b> LEIRAS OY [FI/FI]; Pansiontie 45-47, SF-20210 Turku (FI).</p> <p><b>(72) Inventor; and</b>  <b>(75) Inventor/Applicant (for US only) :</b> LEHTINEN, Matti [FI/FI]; Lemuntie 143, SF-20760 Piispanristi (FI).</p> <p><b>(74) Agent:</b> OY JALO ANT-WUORINEN AB; Laivurinrinne 2 A, SF-00120 Helsinki (FI).</p>		<p><b>(81) Designated States:</b> AU, BR, CA, DE, DE (Utility model), ES, HU, JP, KP, KR, NO, RU, US, European patent (AT, BE, CH, DE, DK, ES, FR, GB, GR, IT, LU, MC, NL, SE), BF (Utility model), BJ (Utility model), CF (Utility model), CG (Utility model), CI (Utility model), CM (Utility model), GA (Utility model), GN (Utility model), ML (Utility model), MR (Utility model), SN (Utility model), TD (Utility model), TG (Utility model).</p> <p><b>Published</b>  <i>With international search report.</i></p>

**(54) Title:** DEVICE FOR INTRAUTERINE USE

**(57) Abstract**

Device for intrauterine use comprising means (7, 8) for attaching the device to the interior wall of the uterus, as well as a member (1) releasing active agent and connected to the said attachment means. The invention is characterized in that the active agent releasing member (1) is in the form of a closed container enclosing the active agent, the walls of the container being at least partly permeable to the active agent.

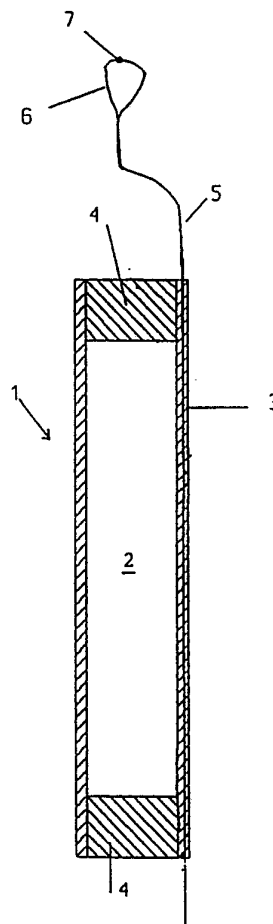

*FOR THE PURPOSES OF INFORMATION ONLY*

Codes used to identify States party to the PCT on the front pages of pamphlets publishing international applications under the PCT.

AT	Austria	FI	Finland	MI	Mali
AU	Australia	FR	France	MN	Mongolia
BB	Barbados	GA	Gabon	MR	Mauritania
BE	Belgium	GB	United Kingdom	MW	Malawi
BF	Burkina Faso	GN	Guinea	NL	Netherlands
BG	Bulgaria	GR	Greece	NO	Norway
BJ	Benin	HU	Hungary	PL	Poland
BR	Brazil	IE	Ireland	RO	Romania
CA	Canada	IT	Italy	RU	Russian Federation
CF	Central African Republic	JP	Japan	SD	Sudan
CG	Congo	KP	Democratic People's Republic of Korea	SE	Sweden
CH	Switzerland	KR	Republic of Korea	SN	Senegal
CI	Côte d'Ivoire	LI	Liechtenstein	SU	Soviet Union
CM	Cameroon	LK	Sri Lanka	TD	Chad
CS	Czechoslovakia	LU	Luxembourg	TG	Togo
DE	Germany	MC	Monaco	US	United States of America
DK	Denmark	MG	Madagascar		
ES	Spain				

## Device for intrauterine use

The object of the present invention is a device for intrauterine use comprising means for attaching the device to the interior wall of the uterus, as well as an active agent releasing member connected to the said attachment means.

Various devices for intrauterine application are widely used for contraceptive purposes. Contraceptives, i.a. releasing copper ions and generally of T-shape, so called spiral-IUDs, one variant of which is also hormone releasing, have today gained extensive use. These contraceptives are fitted by means of an insertion tube into the uterus, wherein they more or less adapt to the interior space of the uterus. Although the preventive effect of these contraceptives generally speaking is good, they have some disadvantages. One such disadvantage is the mechanical strain of the T-hook on the walls of the uterus, which may lead to the breaking of the wall structure, or even to the hook growing into the wall.

Also contraceptive devices have been proposed in the literature which are attached to the wall of the uterus, usually its back wall. In this case the contraceptive need not be hook-shaped and there is no risk of the contraceptive discharging from the uterus. One such solution is disclosed in the US-patent specification 4,708,134, which comprises successive hollow tubular bodies, especially of copper, attached to a thread, which tubular construction can be attached to the inner wall of the uterus by means of a hook or a knot connected with the thread. Another device to be attached with a hook to the wall of the uterus is known from the EP-patent specification A 0100924, according to which a string of copper beads, either in the form of a single strand or a loop, is attached to a hook. This device is fitted in its place with a special, relatively large

insertion device, which, when turned, makes the upper end of the hook correspondingly turn and attach to the wall of the uterus. Both devices are complicated to their construction and the latter especially to its way of insertion, which substantially decreases their application possibilities.

From the WO-publication WO90/05507 a device for attachment to the uterus wall is known, wherein the active agent releasing member is of polymer fibres in the form of individual fibre strands or fibre loops. Although the detailed structure of the fibres has not been described in the said publication, it is evident that they are formed of a polymer permeable to active agent, e.g. steroids, into the matrix of which the active agent is distributed and wherefrom it diffuses out. Such matrix-active agent systems do, however, exhibit some disadvantages, especially as regards the release profile of the active agent. The release rate of the active agent is dependant on both the concentration of the active agent in the matrix, as well as on the surface area of the matrix body. When the matrix is degraded due to the conditions within the uterus and the release of active agent, the permeability of the active agent and thus the release rate increases. As this process cannot be controlled, the release of active agent will be uneven and thus unreliable.

According to the invention a device has now been developed which eliminates the afore mentioned disadvantages and which allows for a reliable and controlled release of active agent into the uterus. Thus the device according to the invention is characterized in that the active agent releasing member is in the form of a closed container enclosing the active agent, at least a part of the walls of the container being permeable to the active agent.

The device according to the invention is advantageously in

the form of a cylinder or a capsule, wherein the walls of the cylinder or capsule are permeable to the active agent. A material suitable for the walls or wall parts is a silicone polymer. A suitable container for the purpose of the invention is obtained by cutting tubular pieces of a suitable length from a thin silicone tube, closing one end thereof by gluing, for example using a silicone glue, filling the tube with the desired active agent, which advantageously is a mixture of active agent and silicone polymer, but which may also be in the form of a liquid or a powder, and subsequently closing the other end of the cylinder in a corresponding manner. Typically such a tubular container has a diameter of at the most a few millimetres, and a length of a few centimeters.

The container is in a suitable manner connected to attachment means for attachment to the uterus wall, for example by a thin thread, which is, for example, a polymer or metal suitable for the purpose. The part to be attached to the wall of the uterus itself may be a knot formed in the thread, for example in a loop thereof, or it may be a hook-shaped member fastened to the thread.

For the purpose of removing the container, a thread of sufficient length is suitably attached to the container so that it extends beyond the cervix when the device is attached to the uterus wall.

The device according to the invention may be inserted in a known manner for example by engaging the loop or hook with a thin stick the end of which is provided with suitably shaped gripping means, such as a small hook, and by inserting the device with the stick, within a suitable hollow insertion tube, through the cervix into the uterus and by attaching the device to the uterus wall. Thereafter the stick is released from the device and the stick and insertion tube are removed.

One and the same thread may be used both for connecting the container to the attachment means, and as a thread for removal. When the container is cylindrical, this can be achieved, for example, by threading the thread with a suitable means through the longitudinal wall structure of the cylinder, substantially along its whole length, or correspondingly through the end wall or walls in the transverse direction of the cylinder. The attachment means is then connected to one end of the thread, and the other end functions as a thread for removal of the device.

With the device according to the invention it is possible to controllably release into the uterus various active agents, especially various hormones, typically estrogens and/or progestins. The device according to the invention is therefore suited especially well for contraceptive purposes, but naturally it may be used also for therapeutic purposes, such as, for example, to treat postmenopausal problems. The use of the device according to the invention for contraceptive and therapeutic purposes thus also forms an object of the invention.

The release rate of the active agent is dependant on i.a. the wall surface area of the container releasing active agent, as well as on the thickness of the wall structure. When using cylindrical capsules of the afore mentioned type, it is possible, when the other parameters of the capsules remain constant, to accurately regulate the duration of the treatment by choosing a capsule of suitable length, or by coupling together in a row several capsules.

The device according to the invention has several advantages. With respect to the said known devices it is simpler to manufacture, and is more dependable to its release profile. Compared to the T-contraceptive widely in use it gives rise to clearly less mechanical strain in the uterus.

It is also advantageous when compared to the known implant capsules to be installed under the skin, especially for contraceptive use. Firstly, it is both easier to insert as well as easier to remove than an implanted capsule, the  
5 implantation of which always requires a small surgical procedure with associated disadvantages. When in intrauterine use, the dose of the active agent is also smaller than that of a systemically administered active agent, even only 1/4 thereof, as the effect is directed directly on the  
10 uterus and its mucous membranes. As the dosage can be reduced, also the possible side effects are reduced.

In the following reference is made to the appended drawing, wherein as an example two embodiments of the invention are  
15 shown.

Figure 1 shows a container of capsular form according to the invention, and Figure 2 an alternative attachment system for the container according to the Figure 1. In both  
20 figures the same reference numerals are used for corresponding parts.

In the embodiment of Figures 1 and 2 the capsule made from a silicone polymer tube is as a whole designated with the  
25 reference numeral 1 and it encloses the active agent 2. The longitudinal walls of the capsule are given the reference numeral 3, and the body member is made from the silicone polymer tube by cutting thereof a piece of suitable length. The ends of the tube closed with silicone glue are given  
30 the reference numeral 4. The capsule is with a thread 5 connected to attachment means, which according to the Figure 1 is comprised of a loop 6 and a knot 7 made therein. In the construction of Figure 2, the attachment means is a hook 8. Both the knot 7 and the hook 8 are  
35 designed to be attached to the wall of the uterus, preferably its back wall. In the embodiment shown, one end of the thread 5 is intended to be connected to the attachment

means, and the other end for removal of the capsule from the uterus. In order to obtain a sufficiently strong connection, the thread 5 is in the example shown (Figure 1) threaded, for example, with a thin needle through the side wall 3 of the capsule which has been suitably softened, such as with a solvent, in its longitudinal direction, or in the alternative embodiment shown in the Figure 2, through the both end wall parts 4 of the capsule. It is of course possible to use different lengths of thread for the attachment means 7 and 8, and for removing the capsule, respectively, by connecting each end part of the capsule to its respective length of thread in a suitable manner.



## Claims

1. Device for intrauterine use comprising means (7, 8) for  
attaching the device to the interior wall of the uterus,  
5 and a member (1) releasing active agent and connected to  
the said attachment means, **characterized** in that the  
active agent releasing member (1) is in the form of a  
closed container enclosing the active agent, at least part  
of the walls of the container being permeable to the active  
10 agent.
2. Device according to claim 1, **characterized** in that the  
closed container is in the form of an extended cylinder or  
capsule.  
15
3. Device according to claim 1 or 2, **characterized** in that  
the wall of the container permeable to the active agent  
is made of a silicone polymer sheet or film.
- 20 4. Device according to any one of the preceding claims,  
**characterized** in that the active agent is estrogen and/or  
progestin.
- 25 5. Device according to any one of the preceding claims,  
**characterized** in that the attachment means is a knot (7)  
or a hook (8) attachable to the uterus wall and connected  
to the container (1) by means of a thread (5).
- 30 6. Device according to claim 5, **characterized** in that the  
thread (5) is threaded in the longitudinal direction  
through the side wall of the capsule shaped container  
substantially along its whole length.
- 35 7. Device according to claim 5, **characterized** in that the  
thread (5) is threaded in the transverse direction through  
the end parts (4) of the capsule shaped container.

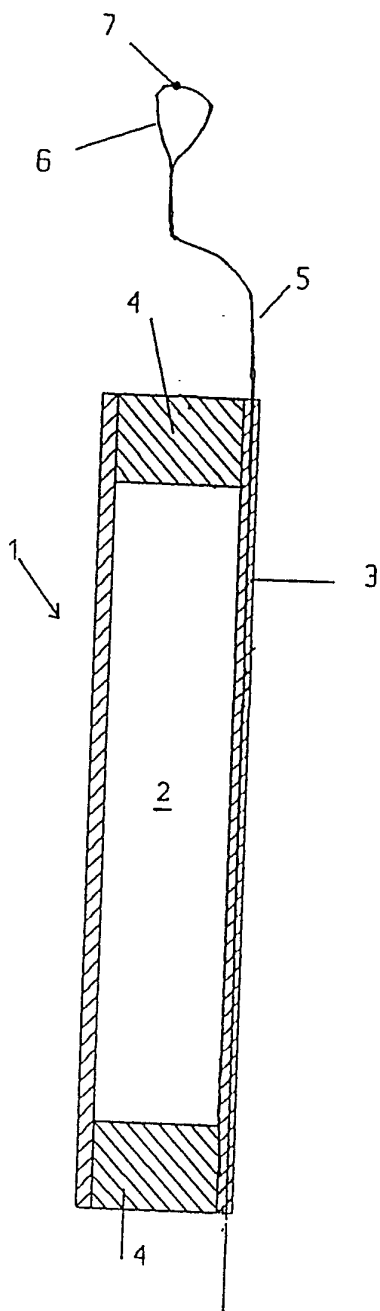

FIG. 1

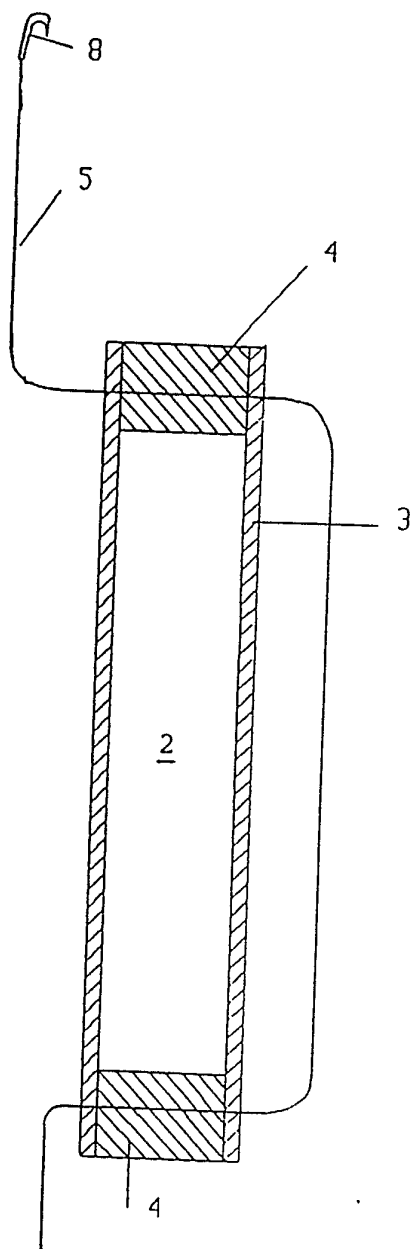



FIG. 2

# INTERNATIONAL SEARCH REPORT

International Application No PCT/FI 92/00189

<b>I. CLASSIFICATION OF SUBJECT MATTER</b> (If several classification symbols apply, indicate all) <sup>6</sup>		
According to International Patent Classification (IPC) or to both National Classification and IPC IPC5: A 61 F 6/14, A 61 M 31/00 // A 61 K 9/02		
<b>II. FIELDS SEARCHED</b>		
Minimum Documentation Searched <sup>7</sup>		
Classification System	Classification Symbols	
IPC5	A 61 F; A 61 M; A 61 K	
Documentation Searched other than Minimum Documentation to the Extent that such Documents are included in Fields Searched <sup>8</sup>		
SE,DK,FI,NO classes as above		
<b>III. DOCUMENTS CONSIDERED TO BE RELEVANT<sup>9</sup></b>		
Category *	Citation of Document, <sup>11</sup> with indication, where appropriate, of the relevant passages <sup>12</sup>	Relevant to Claim No. <sup>13</sup>
X	EP, A1, 0082894 (THE POPULATION COUNCIL, INC.) 6 July 1983, see page 2, line 15 - line 29; figure 1 --	1-3,5
X	US, A, 3896819 (ZAFFARONI ET AL) 29 July 1975, see column 13, line 27 - line 30; column 22, line 50 - line 59; figure 5 --	1-4
A	WO, A1, 9100714 (WILDEMEERSCH, DIRK) 24 January 1991, see abstract; figure 1 --	1,5-7
A	US, A, 4708134 (WILDEMEERSCH) 24 November 1987, see abstract; figure 9 -- -----	1-2,5-6
<p>* Special categories of cited documents:<sup>10</sup></p> <p>"A" document defining the general state of the art which is not considered to be of particular relevance</p> <p>"E" earlier document but published on or after the international filing date</p> <p>"L" document which may throw doubts on priority claim(s) or which is cited to establish the publication date of another citation or other special reason (as specified)</p> <p>"O" document referring to an oral disclosure, use, exhibition or other means</p> <p>"P" document published prior to the international filing date but later than the priority date claimed</p> <p>"T" later document published after the international filing date or priority date and not in conflict with the application but cited to understand the principle or theory underlying the invention</p> <p>"X" document of particular relevance, the claimed invention cannot be considered novel or cannot be considered to involve an inventive step</p> <p>"Y" document of particular relevance, the claimed invention cannot be considered to involve an inventive step when the document is combined with one or more other such documents, such combination being obvious to a person skilled in the art.</p> <p>"&amp;" document member of the same patent family</p>		
<b>IV. CERTIFICATION</b>		
Date of the Actual Completion of the International Search	Date of Mailing of this International Search Report	
25th September 1992	30 -09- 1992	
International Searching Authority	Signature of Authorized Officer	
SWEDISH PATENT OFFICE	 Leif Brander	

**ANNEX TO THE INTERNATIONAL SEARCH REPORT  
ON INTERNATIONAL PATENT APPLICATION NO. PCT/FI 92/00189**

This annex lists the patent family members relating to the patent documents cited in the above-mentioned international search report. The members are as contained in the Swedish Patent Office EDP file on **28/08/92**.  
The Swedish Patent Office is in no way liable for these particulars which are merely given for the purpose of information.

Patent document cited in search report	Publication date	Patent family member(s)	Publication date
EP-A1- 0082894	83-07-06	NONE	
US-A- 3896819	75-07-29	US-A- 3854480	74-12-17
		AT-B- 336189	77-04-25
		AU-B- 467246	75-11-27
		AU-D- 4696972	74-03-28
		BE-A- 789524	73-01-15
		CA-A- 993358	76-07-20
		CH-A- 576794	76-06-30
		DE-A-C- 2247949	73-04-05
		FR-A-B- 2158201	73-06-15
		GB-A- 1414812	75-11-19
		NL-A- 7213250	73-04-03
		SE-B-C- 396695	77-10-03
		US-A- 3845761	74-11-05
		US-A- 3948262	76-04-06
		US-A- 3967618	76-07-06
		US-A- 3993073	76-11-23
WO-A1- 9100714	91-01-24	AU-D- 5927390	91-02-06
		CN-A- 1048495	91-01-16
		EP-A- 0482022	92-04-29
US-A- 4708134	87-11-24	AU-B- 578339	88-10-20
		AU-D- 5250986	86-08-14
		BE-A- 901652	85-05-29
		CA-A- 1243912	88-11-01
		DE-A- 3660195	88-06-23
		EP-A-B- 0191747	86-08-20
		JP-A- 61240955	86-10-27