

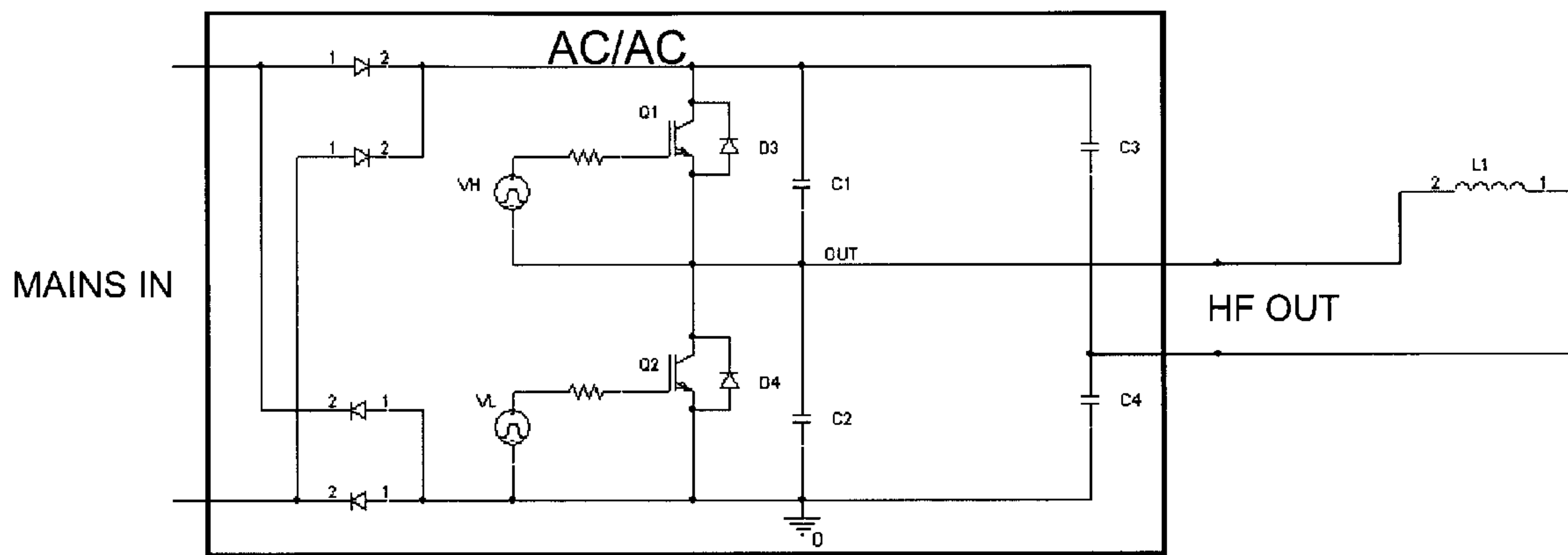

(22) Date de dépôt/Filing Date: 2010/07/23
 (41) Mise à la disp. pub./Open to Public Insp.: 2011/04/05
 (45) Date de délivrance/Issue Date: 2017/08/22
 (30) Priorité/Priority: 2009/10/05 (EP09172198.5)

(51) Cl.Int./Int.Cl. *H05B 6/12* (2006.01),
H05B 6/06 (2006.01)
 (72) Inventeurs/Inventors:
PARACHINI, DAVIDE, IT;
DEL BELLO, FRANCESCO, IT;
DE ANGELIS, ANDREA, IT;
PADERNO, JURIJ, IT
 (73) Propriétaires/Owners:
WHIRLPOOL CORPORATION, US;
TEKA INDUSTRIAL S.A., ES
 (74) Agent: RIDOUT & MAYBEE LLP

(54) Titre : METHODE D'ALIMENTATION DES ZONES DE CUISSON PAR INDUCTION D'UN PLAN DE CUISSON PAR INDUCTION POURVU DE CONVERTISSEURS DE SECTEUR, PLAN DE CUISSON PAR INDUCTION FAISANT APPEL A CETTE METHODE
 (54) Title: METHOD FOR SUPPLYING POWER TO INDUCTION COOKING ZONES OF AN INDUCTION COOKING HOB HAVING A PLURALITY OF POWER CONVERTERS, AND INDUCTION COOKING HOB USING SUCH METHOD



(57) **Abrégé/Abstract:**

A method for supplying power to induction cooking zones of an induction cooking hob with a plurality of power converters, each feeding an induction heating element, comprises feeding all the induction heating elements according to a predetermined and repetitive driving sequence in order to keep a predetermined delivered power to the induction heating elements and according to the user input.

ABSTRACT

A method for supplying power to induction cooking zones of an induction cooking hob with a plurality of power converters, each feeding an induction heating element, comprises feeding all the induction heating elements according to a predetermined and repetitive driving sequence in order to keep a predetermined delivered power to the induction heating elements and according to the user input.

**METHOD FOR SUPPLYING POWER TO INDUCTION COOKING ZONES OF
AN INDUCTION COOKING HOB HAVING A PLURALITY OF POWER
CONVERTERS, AND INDUCTION COOKING HOB USING SUCH METHOD**

5 This application claims priority on EP Patent Application No. 09172198.5 filed
October 5, 2009.

 The present invention relates to a method for supplying power to induction cooking
zones of an induction cooking hob with power converters, each of such power converters
feeding an inductor.

10 It is well known that an induction cooking system comprises two main components,
i.e. an AC/AC power converter (usually of the resonant type) that transforms the mains
line voltage (ex. 230V, 50Hz in many EU countries) into a high frequency AC voltage
(usually in the 20-50kHz range) and an inductor that, when a cooking vessel is placed on
it, induces a high frequency magnetic field into the cooking vessel bottom that, by Joule
15 effect caused by induced eddy current, heats up.

 From the user point of view, it is desirable that the power delivered to the cooking
vessel can be adjusted, according to the recipe chosen by the user, from a minimum to a
maximum power, and such feature can be obtained by adjusting some working
parameters of the AC/AC converter, such as the operating frequency of the output signal
20 and/or the operating voltage of the output signal. When an induction cooking system
comprises more than one inductor, it may happen that some electric or magnetic coupling
exists between the AC/AC converters and/or the inductors, or that a limitation on the sum
of the power delivered by the inductors does exist because of limited rating of the mains
line power. Said electric or magnetic couplings result in generation of audible noise when
25 two coupled converters or inductors are operated at different frequencies (whose
difference lies in the audible range) and cause excessive disturbances on the mains line
that can exceed the standard compliance limitation. Furthermore mains line rating
limitation on the maximum available power requires that a common control prevents the
total power delivered by the converters connected to a mains line from exceeding the
30 prescribed limit.

 To avoid audible disturbances when operating two coupled induction cooking
systems (each having AC/AC inverter plus inductor) both systems shall be operated at
the same frequency or at frequencies whose difference lies outside the audible range, but
the operation at different frequencies can result in increased mains line disturbance level,
35 so that it is preferable to avoid this condition. In order to allow the required flexibility in the
power setting and adjustment, the operating voltage of the AC/AC converter should be
used as control parameter.

Those skilled in the art of induction cooking systems know very well that changing the output voltage is difficult to be implemented in a cost effective way for the kind of resonant converters normally used in induction cooking systems. For half bridge series resonant converters, among the possible ways to change and therefore adjust the output voltage, a possible solution is to operate on the power switches activation duty cycle. This is probably the easiest way in theory, but as soon as a deeper investigation on the switching condition is carried out, it can be seen that deviating from the standard operating condition of the switches control (duty cycle=50%) can result in loss of soft switching working condition on the power switches, and in severe switching loss increase that can lead to device overheating and also to failure thereof. In view of the above, we can say that such way of changing the output voltage should be used only for "small" changes (approximately for a power regulation in the range 2:1, which allows to keep the soft switching condition) while the required flexibility for commercial induction cooking systems is to have a power ratio as high as 100:1. Other ways to change the output voltage are known (for example using silicon-controlled rectifier SCR on the rectifying bridge to reduce the mains voltage rms value, or introducing a Boost or Buck regulator ahead of the half bridge circuit), but they require additional costs that make the product economy not attractive for the market. A technical solution of this kind is disclosed by EP-A-1895814.

Another way to avoid audible noise generation is described in WO 2005/043737 where the operation of two coupled induction systems is allowed when the frequency difference lies outside the audible frequency range (~20Hz-20kHz). By combining this feature with the voltage change a higher flexibility in the operation can be obtained, but higher disturbance level is generated on the mains line.

Another way to limit the power can be an ON/OFF operation of an induction system, meaning that for example to get 500W out of a converter, the latter can be operated at 1000W for half of the operating time. This method becomes effective when the control cycle time is much smaller than the thermal time constant of the cooking vessel, so that the average power is delivered to the food being cooked without the user perceiving the power modulation.

The last method described above can be used alone to control the delivered power only with special care, since it can involve big power steps, and consequently high flicker values that can annoy the customer and cause the product failing the standard IEC relevant test, so either the power step must be kept low or the cycle time must be made high enough to limit the flicker value, but a limit exists as mentioned before that the cycle time should be much smaller than the cooking vessel thermal time constant, otherwise the customer will strongly perceive the ON/OFF modulation in the cooking process.

A similar control method for controlling two inductors is described in EP-A-1951003, and it solves the problem for a cooking system made of two inductors coupled by the mains, as shown in the attached figure 2. The technical solution disclosed in this document can solve only one of the coupling problems at a time, but it is not able to solve the whole problem of several power converters and inductors, because it does not create enough degree of freedom in the system to match the user setting and the system constrains.

An object of the present invention is to provide a method which solves the above problems by delivering the required power to a plurality of interconnected induction cooking systems, some of them being coupled because of mains line sharing (figure 2) or inductors/cooking vessel (figure 3) sharing, maximizing the efficiency and limiting the noise and the flicker emission.

The method according to the invention relies on the basic principle that the required power is delivered to each cooking vessel on a time average (control cycle), meaning that during the control cycle, that can be repeated on and on for an infinite time, the constraints for guaranteeing the absence of noise, flicker and power rating limitation are fulfilled at each time, while the power set by the user is delivered in average during the control cycle.

The method according to the invention allows the best flexibility in power delivery, without losing efficiency in the system. Moreover, the method according to the invention solves the problem of extending the control strategy to more than two coupled induction cooking systems with different types of couplings, the technology available up to now enabling too few degrees of freedom for the number of constrains present in the system like for example the one depicted in figure 5.

Further advantages and features according to the present invention will be clear from the following detailed description, with reference to the attached drawings in which:

- figure 1a shows a typical circuit for driving an inductor and comprising a power converter;
- figure 1b is a schematical view on an induction cooking system using the power converter of figure 1a;
- figure 2 is a schematical view similar to figure 1b and it shows two power converters driven by a central process unit and sharing the same mains line;
- figure 3 is similar to figure 2 in which two power converters are fed through different mains lines and drive two magnetically coupled inductors which heat the same pot;

- figure 4 is similar to figure 3 in which the two power converters share the same mains line;
- figure 5 is a schematical view of an induction cooking hob having a plurality of power converters and inductors, some converters sharing the mains lines and some inductors sharing the same pot;
- figure 6 is similar to figure 5 in which each heating zone has two shared inductors;
- figure 7 shows the power vs. frequency relationship of the four power converters of figures 5 and 6;
- figures 8a and 8b show a typical pattern of how the power is delivered from power converters in a certain time frame and according to the user requirements, and particularly figure 8a shows the power delivered on each of the four inductors during the cycle time, while figure 8b shows the power absorbed by each mains line, according to the same control sequence;
- figure 9a and 9b shows known methods to achieve power regulation using output voltage modulation based on SCR devices on the bridge rectifier (in figure 9a elements T1, T2) and Buck conversion (in figure 9b elements Q3, L2, D3); and
- figures 10, 11 and 12 show examples of control cycles.

20 With reference to the drawings, in figure 5 it is shown an induction cooking system made of four AC/AC converters 2a, 2b, 2c and 2d of the same type of the single converter shown in figures 1a and 1b. Two of such converters, particularly 2a and 2c, are coupled by the mains line (indicated in the drawings with the reference MAINS 1 IN). The induction cooking system comprises four inductors 4a, 4b, 4c and 4d, two of them, particularly 4c and 4d, being magnetically coupled and sharing the same cooking vessel 5c.

30 When inductors 4a and 4c works together through AC/AC converters 2a and 2c, such converters must be operated at the same switching frequency and the total power shall be limited by the mains and AC/AC converter rating, i.e. usually without exceeding 16 A on each mains power line. When inductors 4b and 4d works together through AC/AC converters 2b and 2d, converters must be operated at the same switching frequency and the total power shall be limited by the mains and AC/AC converter rating. When inductors 4c and 4d works together through AC/AC converters 2c and 2d, converters must be operated at the same switching frequency and the total power shall be limited by the mains and AC/AC converter rating.

35 If the user of the system described in figure 5 asks for a certain power setting that includes all inductors 4a, 4b, 4c and 4d, the known methods, and particularly the method

described in EP-A-1951003, applied to couples of converters, would not give the required performances in terms of power delivery, acoustic noise or flicker emission.

The control cycle that satisfies the system requirements and the user requirements is made, according to the present invention, by a finite sequence of elementary actuation steps, selected among all the possible for the specific system configuration each one matching the system constrains. A table showing all possible system configurations is as follows:

Configuration	Converter status			
	2a	2b	2c	2d
1	OFF	OFF	OFF	OFF
2	OFF	OFF	OFF	ON
3	OFF	OFF	ON	OFF
4	OFF	OFF	ON	ON
5	OFF	ON	OFF	OFF
6	OFF	ON	OFF	ON
7	OFF	ON	ON	OFF
8	OFF	ON	ON	ON
9	ON	OFF	OFF	OFF
10	ON	OFF	OFF	ON
11	ON	OFF	ON	OFF
12	ON	OFF	ON	ON
13	ON	ON	OFF	OFF
14	ON	ON	OFF	ON
15	ON	ON	ON	OFF
16	ON	ON	ON	ON

where the first column shows the reference number of a specific system configuration and the other four columns show the ON or OFF condition of each power converters. For an induction cooking system made of N AC/AC converter each one feeding an inductor, 2^N is the number of available configuration of activation.

Figure 8a shows an example of an optimal sequence for driving all the inductors according to the predetermined input from the user (in this case all the four inductors are in an average switched-on configuration) in which the driving sequence has a duration of

1 second. Typically the duration of the driving sequence may be comprised between 0,1 second and 5 seconds. Figure 8b, derived from figure 8a, shows the power sequence of two couples of inductors 2a+2c and 2b+2d respectively of figures 5 and 6, that shows how small is the power variation along the control cycle and consequently small is the flicker induced on the mains lines.

It is clear that the cycle must not only match the user requirements, but also the requirements set by the following:

10	Elementary step 1(configuration 16) $P1a+P1c < Pmains1max; P1b+P1d < Pmains2max$	T1: $f2a=f2c=f2b=f2d$	
	Elementary step 2 (configuration 10)	T2: $f2a=f2d$	$P1a < Pmains1max; P1d < Pmains2max$
	Elementary step 3 (configuration 4) $P1b+P1d < Pmains2max$	T3: $f2c=f2d$	$P1a+P1c < Pmains1max;$

15 To calculate the activation sequence (figures 8a and 8b), one or more microcontrollers 9 installed in the system has to first measure the power versus frequency characteristic of each AC/AC converter in the system in which the power activation is required by the user (like those depicted in figure 7). Then using these data and the user input requirements, the microcontroller 9 looks for the right activation sequence that matches the system constraints (shown in the above formulae) and user constraints. The microprocessor can achieve this goal by using the most recent mathematical optimization techniques, or advanced genetic algorithms, or an iterative process in which the best actuation sequence is searched among all the possible sequences that fit the user and system requirements.

25 A possible way for the microcontroller 9 to calculate the activation sequence is to use an iterative search process like:

0: After the user has inputted the power setting, the microcontroller 9 actuates the power converters in order to sequentially acquire each hob (among those requiring non zero power by the user) power curve, as shown in figure 7. It is preferable for those inductors having a magnetic coupling to acquire also a power curve by actuating the two coupled inductors at the same time;

1: Consider a configuration from the 2^N possible (see table above for example) and that has at least one converter output required by the user switched ON;

2: Search the frequency/frequencies of the first step of the activation sequence that correspond to a target power absorbed by each mains line equal at least to the total average power required by the user on said mains line. If at the end of the search process this power turns out to be not enough for to fulfil the user power requests, the target power of the first step can be incremented in finite steps within the mains limit;

3: Calculate the time fraction over the cycle time it takes for at least a first output to fulfil its user requirements with the selected frequency; after this elementary step this output will no longer be activated;

4: Calculate the residual energy requirement for the remaining outputs in the remaining cycle time and jump to step 1 excluding from the user requirements the one already fulfilled. When the calculated sequence does not fit in the control cycle time, a new starting configuration shall be selected in step 1.

The process stops when either all user requests are fulfilled or when there are no more configurations to be considered (in such case the solution that best fit user requirements will be selected).

The above procedure may result is more than a solution changing the starting point (the actuation configuration selected for the initial step). In case more than one solution is found, the one exhibiting the lowest mains power change during the cycle is selected in such a way to reach the lowest flicker solution.

As an example of the above mentioned procedure, consider the following situation, applicable to a system like the one depicted in Figure 5 with power curves depicted in figure 10 (right side):

User power settings:

Converter	Power
2a	1400W
2b	1000W
2c	1000W
2d	2000W

Consider configuration 10 from previous table (it has two of the four required output enabled). Since there is not interaction both between mains and inductors on converters 2a and 2d, the switching frequency can be different in the two converters. The two switching frequencies can be found using power curves shown in figure 10 on the right side starting using as power setting

$P_{mains1}=P_{2a}+P_{2c}=2520W$, $P_{mains2}= P_{2b}+P_{2d}=3130W$:

$F_{2a_1}=21250Hz$; $F_{2d_1}=22100Hz$

With these power setting we can calculate the time needed to fulfil at least one user setting by dividing the required power by the actuated power, the division resulting in 0.557 for 2a and 0.639 for 2d, so the configuration 10 will last for the smaller one i.e. 55.7% of the cycle time delivering the following energy (the Joule unit is for convenience only and it will be true with a cycle time of 1 second):

E2a_1=1400J ; E2b_1=0J
E2c_1=0J ; E2d_1=1750J

So all the user required energy has been delivered to output 2a, while still 250J are required on output 2d in the remaining 44.3% of the cycle time.

- 5 Select configuration 8 from table 1, output 2b, 2c and 2d are coupled, so their activation cannot be calculated separately. Using curves in figure 10 and the mains power setting so that the mains power exhibit the smallest change, select the switching frequency that satisfies at least one of the mains power setting:

P2a_2=0 ; P2b_2=1420W
10 P2c_2=1900W ; P2d_2=1720W

From figure 10 it follows that to get these power at output 2b, 2c and 2d the switching frequency has to be set to (since Output 2c and 2d are coupled, the power curve to be used in this case has to be acquired activating together the two outputs, resulting in the JC and JD curves in figure 10) :

15 F2b_2=F2d_2=26400Hz ; F2c_2=26400Hz

The above configuration shall last for 15% of the cycle time, at the end of which the output 2d will have completely fulfilled the user requirement.

- 20 Select configuration 7 from table 1, output 2b and 2c are not coupled, so their activation can be calculated separately. Using curves in figure 10 and the mains power setting so that the mains power exhibit the smallest change, select the switching frequency that satisfies the remaining energy requirements (since they are independent):

P2a_3=0 ; P2b_3=2680W
P2c_3=2430W ; P2d_3=0W

- 25 From figure 10 it follows that to get these powers at output 2b, 2c the switching frequency has to be set to:

F2b_3=20500Hz ; F2c_3=23900Hz

Configuration 7 will last for the remaining 29.3% of the cycle time.

- 30 Calculating the average power on each output as specified in figure 8a it can be easily seen that the above user setting are satisfied with a sequence like the one depicted in figure 10.

Other examples of control sequences are depicted in figures 11 and 12, showing how different can be the control sequences depending on the power curves and user requests.

Figure 11 shows the control cycle for the following user request:

35 P2a=500W ; P2b=500W

9

P2c=2500W ; P2d=2500W

Achieved through a sequence of configurations 16, 7, 4

Figure 12 shows the control cycle for the following user request:

P2a=500W ; P2b=600W

5 P2c=300W ; P2d=600W

Achieved through a sequence of configurations 7, 13, 10

What is claimed is:

1. A method for supplying power from one or more mains lines to induction heating zones of an induction cooking hob with a plurality of power converters each feeding electrical power to an associated induction heating element, said method comprising:
obtaining a user input representing a selected average power level setting for each power converter and associated induction heating element; and
feeding the induction heating elements according to a predetermined and repetitive driving sequence configured on a control unit in order to deliver power to each induction heating element according to the selected average power level, wherein the driving sequence is an optimum sequence as compared to a plurality of possible sequences stored on the control unit.
2. The method according to claim 1, wherein the repetitive driving sequence has a cycle time duration between 1 second and 5 seconds.
3. The method according to claim 1, further comprising feeding two of the plurality of power converters from a single mains line of the one or more mains lines and preventing the driving sequence from drawing more than a predetermined amount of current from the single mains line.
4. The method according to claim 1 wherein the optimal repetitive driving sequence is selected based on having at least one of the lowest mains power change during a cycle, lowest acoustic noise and lowest flicker emission.
5. The method according to claim 1, further comprising: determining electrical constraints of the induction cooking hob;
assessing a power versus frequency characteristic of each power converter;
determining an operating frequency of each converter according to the selected power level setting for each induction heating element; and
determining an optimal repetitive driving sequence based on the selected average power level for each induction heating element and the electrical constraints of the induction cooking hob.

6. The method according to claim 5, wherein determining the optimal repetitive driving sequence further comprises:

choosing a configuration of induction heating elements from 2^N possible configurations, where N is the number of selected induction heating elements and the configuration indicates which selected power converters are to be powered;

actuating the selected power converters to acquire power curves of the selected power converters;

determining a frequency for each selected power converter that corresponds to a target power absorbed by each mains line;

calculating a time fraction required per cycle time duration that the selected power converters have to be activated to provide the selected average power level for at least one selected power converter;

calculating a residual energy requirement for any induction heating elements that are not powered to their selected average power level during the time fraction;

choosing another configuration of induction elements from the 2^N possible configurations and the other configuration indicates selected power converters are to be powered;

actuating the selected power converters to acquire power curves of the selected power converters of the other configuration;

determining a frequency for each selected power converter of the other configuration that corresponds to another target power absorbed by each mains line; and

calculating a time fraction required per cycle time duration that the selected power converters of the other configuration have to be activated to provide the residual level for at least one selected power converter of the other configuration.

7. An induction cooking hob comprising:

a plurality of induction heating elements;

a user input for selecting an average power level for each of the plurality of induction heating elements;

a plurality of power converters each feeding an associated one of the plurality of induction heating elements; and

a control unit directing the plurality of power converters to feed power to the plurality of induction heating elements according to a predetermined and repetitive driving sequence to deliver power to each induction heating element according to the selected average power level set through the user input, wherein the driving sequence is an optimum sequence stored on the control unit and is compared to and selected from a plurality of possible sequences stored on the control unit based on the user input and a system constraint.

8. The induction cooking hob according to claim 7, wherein the control unit is configured to:
 - determine electrical constraints of the induction cooking hob;
 - assess a power versus frequency characteristic of each power converter;
 - determine an operating frequency of each converter according to the selected average power level for each induction heating element; and
 - determine the optimal repetitive driving sequence based on the selected average power level for each induction heating element and the electrical constraints of the induction cooking hob as compared to the plurality of possible sequences stored on the control unit.
9. The induction cooking hob according to claim 7, wherein the repetitive driving sequence has a cycle time duration between 1 second and 5 seconds.
10. The induction cooking hob according to claim 7, where two of the plurality of power converters are fed by a single mains line and the control unit prevents the driving sequence from drawing more than a predetermined amount of current from the single mains line.
11. The induction cooking hob according to claim 7, wherein the predetermined and repetitive driving sequence includes a cycle time duration divided into time fractions, each time fraction has an associated configuration of induction heating elements from 2^N possible configurations, where N is the number of selected induction heating elements

and the configuration indicates which selected power converters are to be powered, and a frequency for each selected power converter that corresponds to a target power absorbed by each mains line whereby the selected average power level is sent to the induction heating elements and acoustic noise and flicker emission are reduced.

12. A method of controlling an induction cooking hob, comprising:
 - inputting a power setting by a user;
 - measuring a power input based on the power setting versus a frequency characteristic of at least two convertors with a microcontroller;
 - searching a data set stored in a microprocessor in the microcontroller; and
 - determining a preferred activation sequence as compared to the data stored and the power input, wherein the preferred activation sequence matches a system constraint and a user constraint, the preferred activation sequence is the best activation sequence among a plurality of predetermined stored sequences as compared to the user and system requirements.

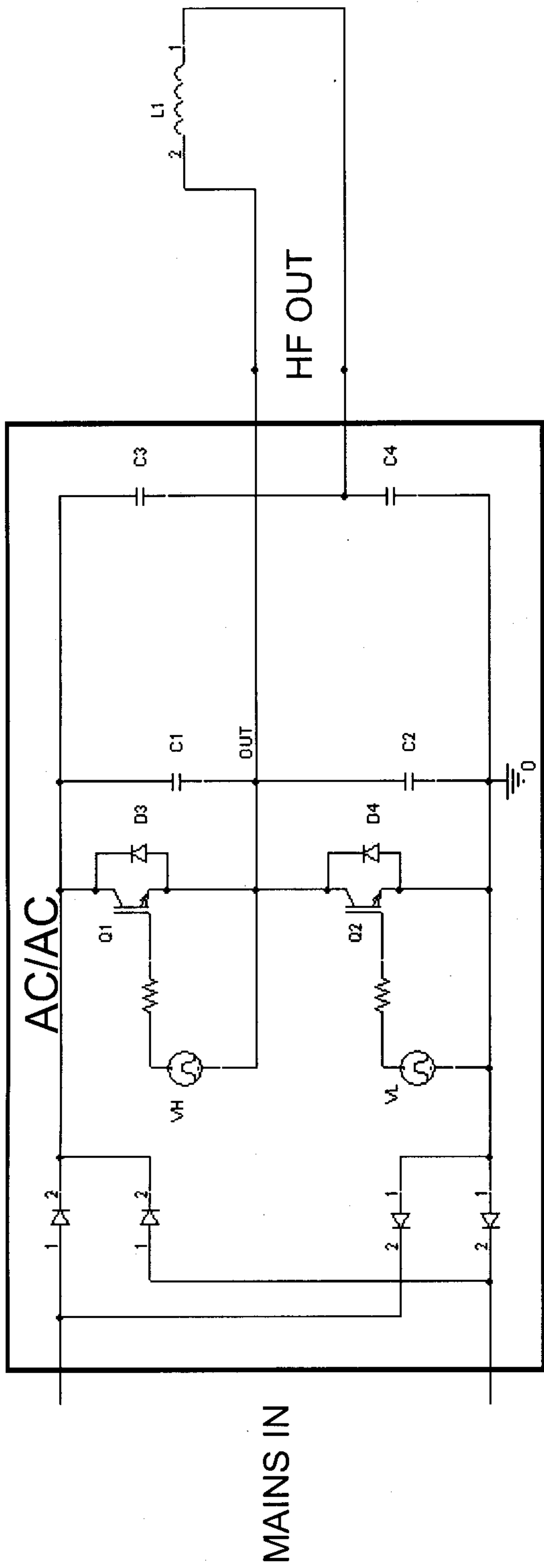

Figure 1a

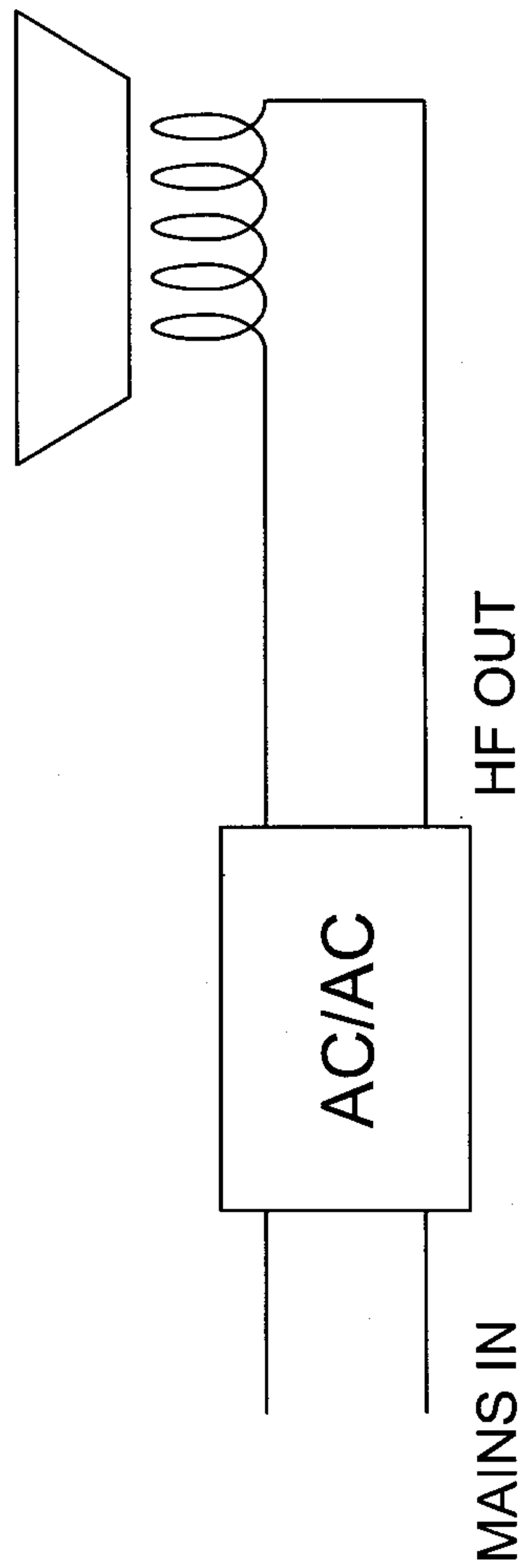

Figure 1b

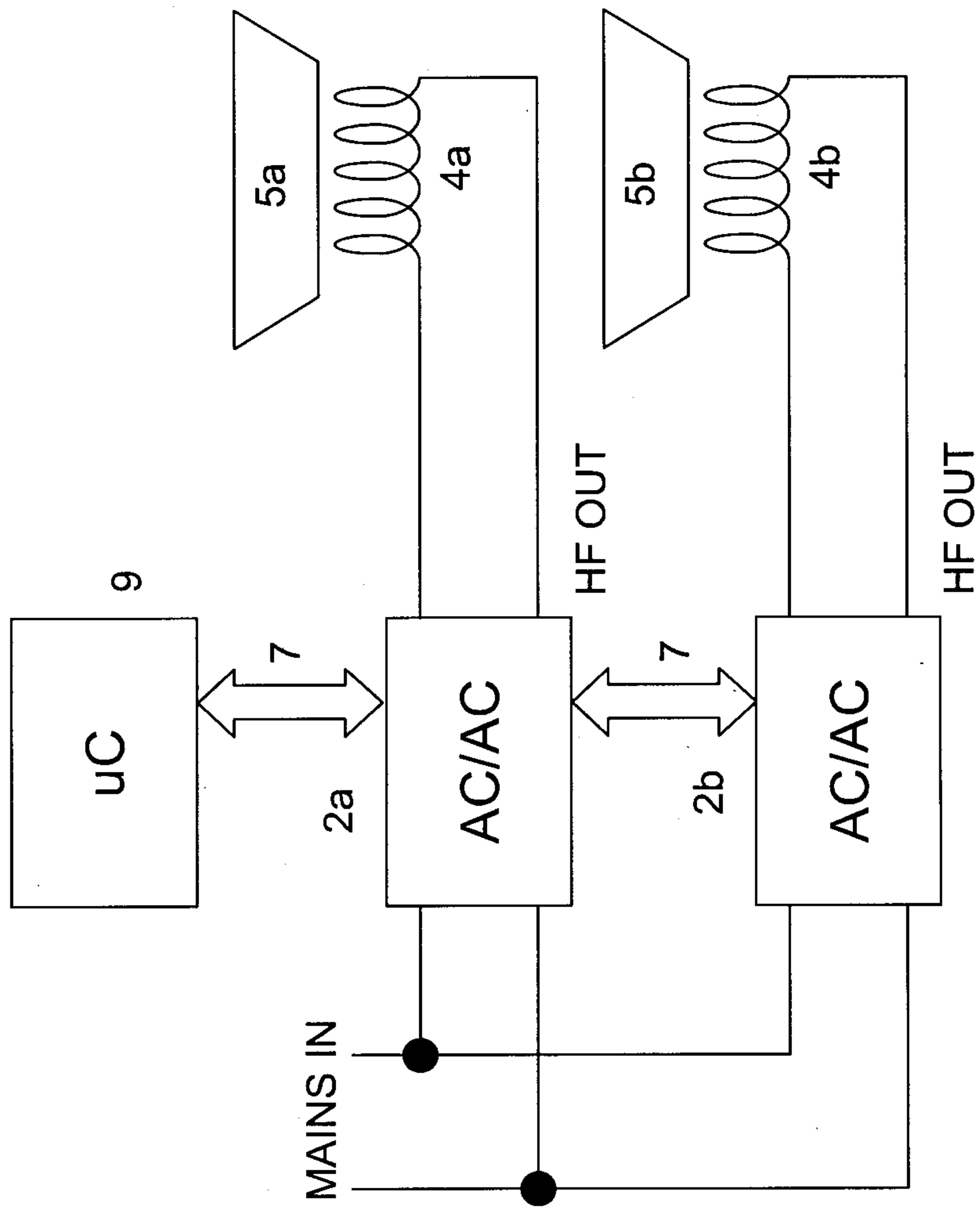

Figure 2

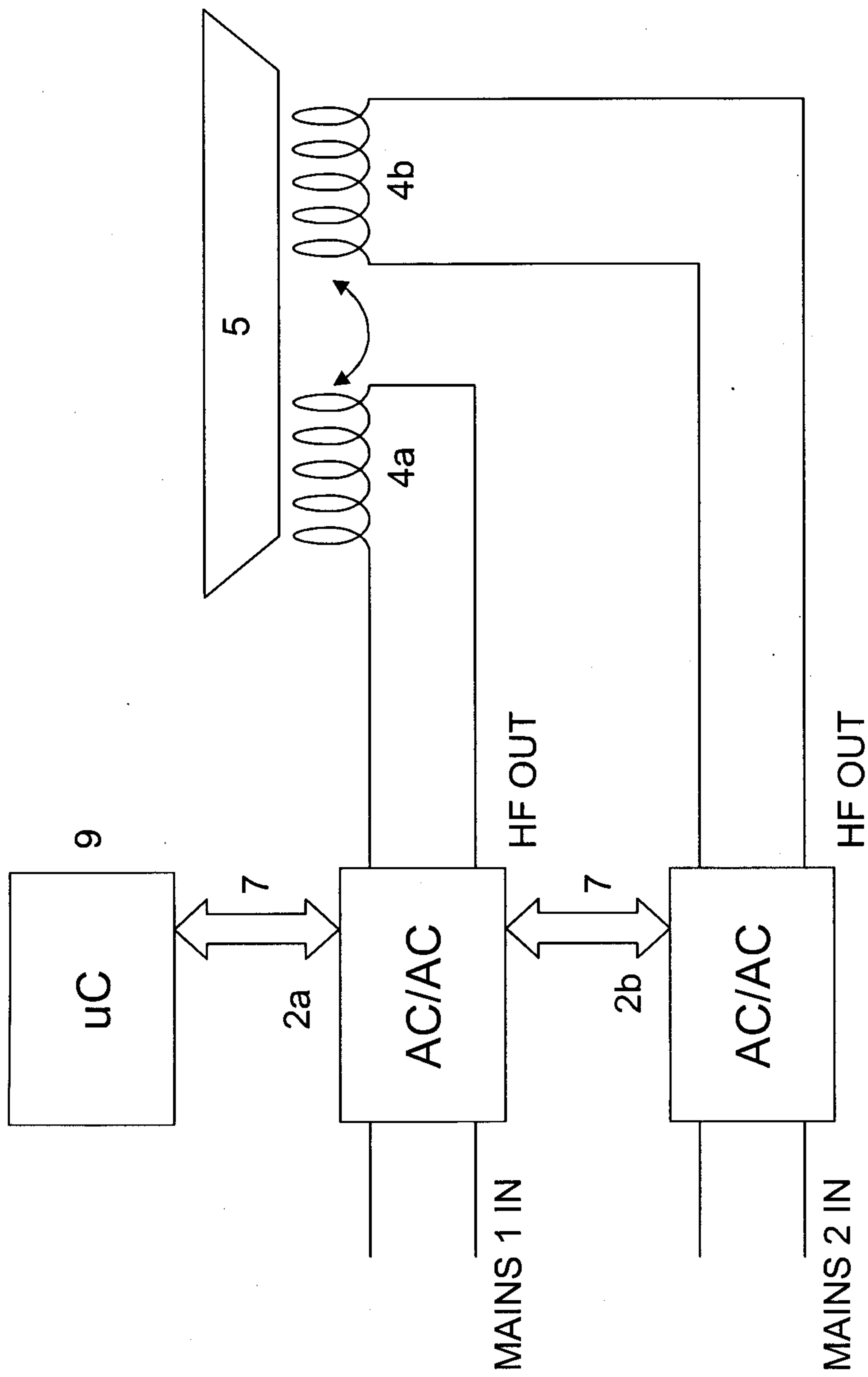

Figure 3

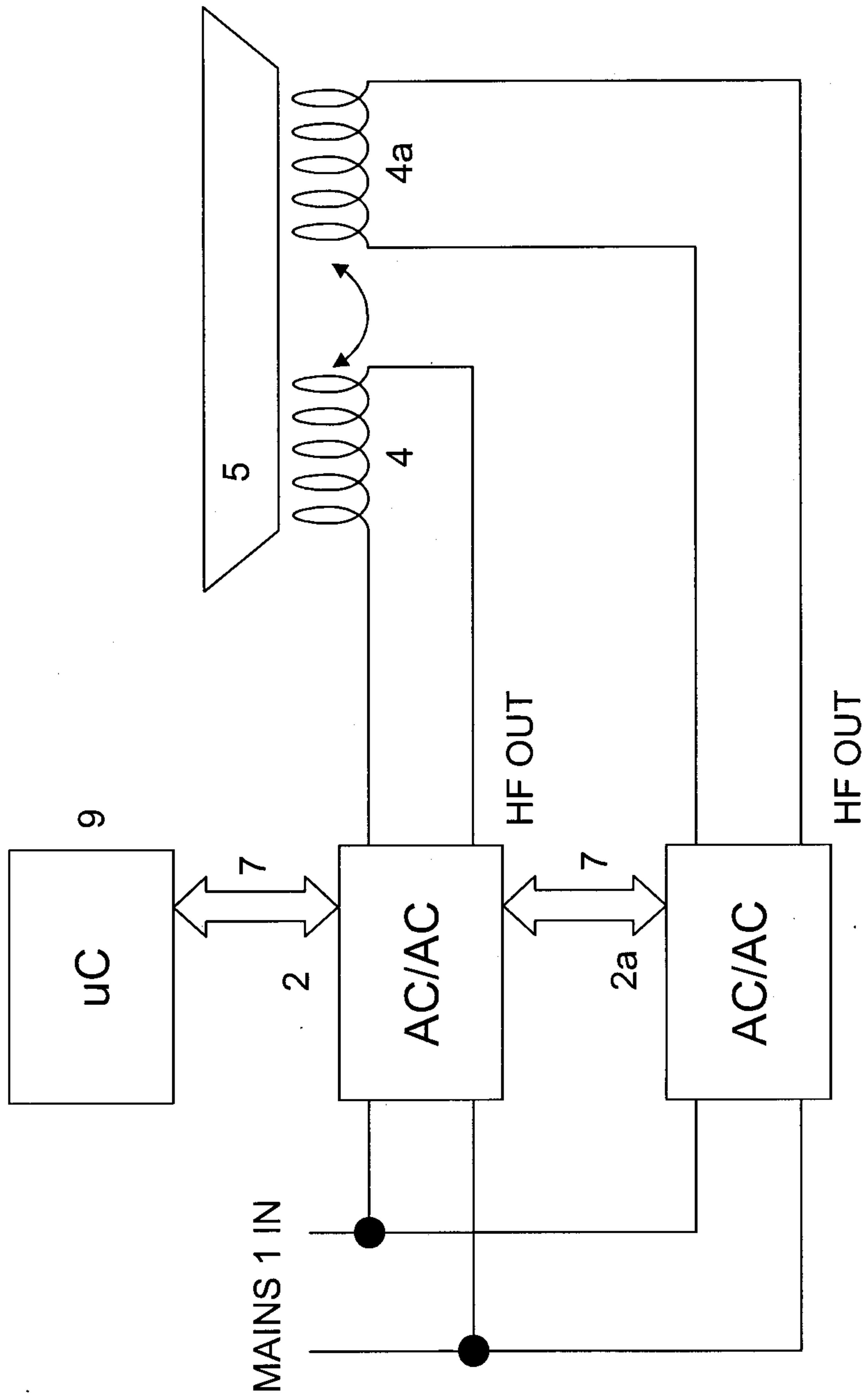

Figure 4

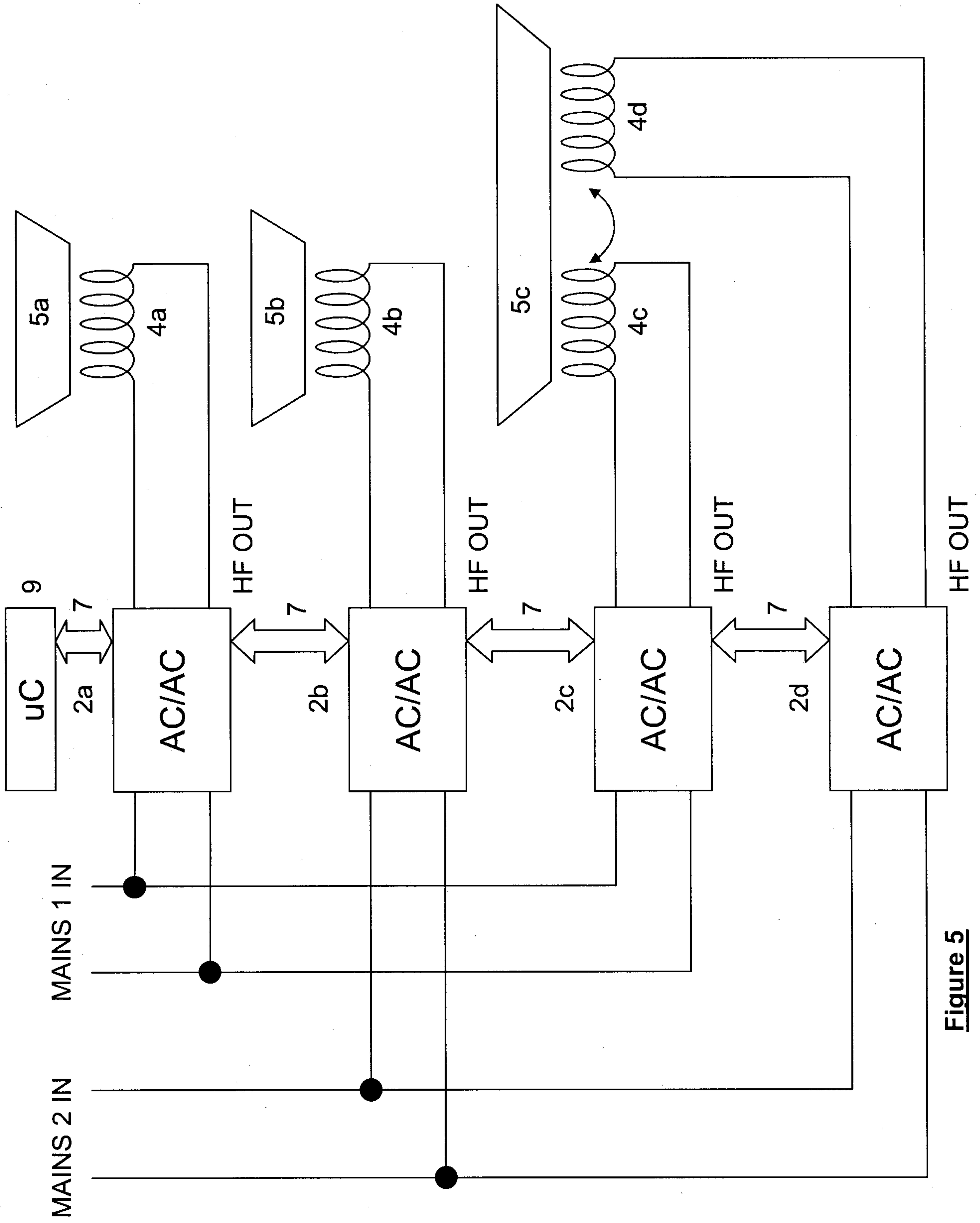

Figure 5

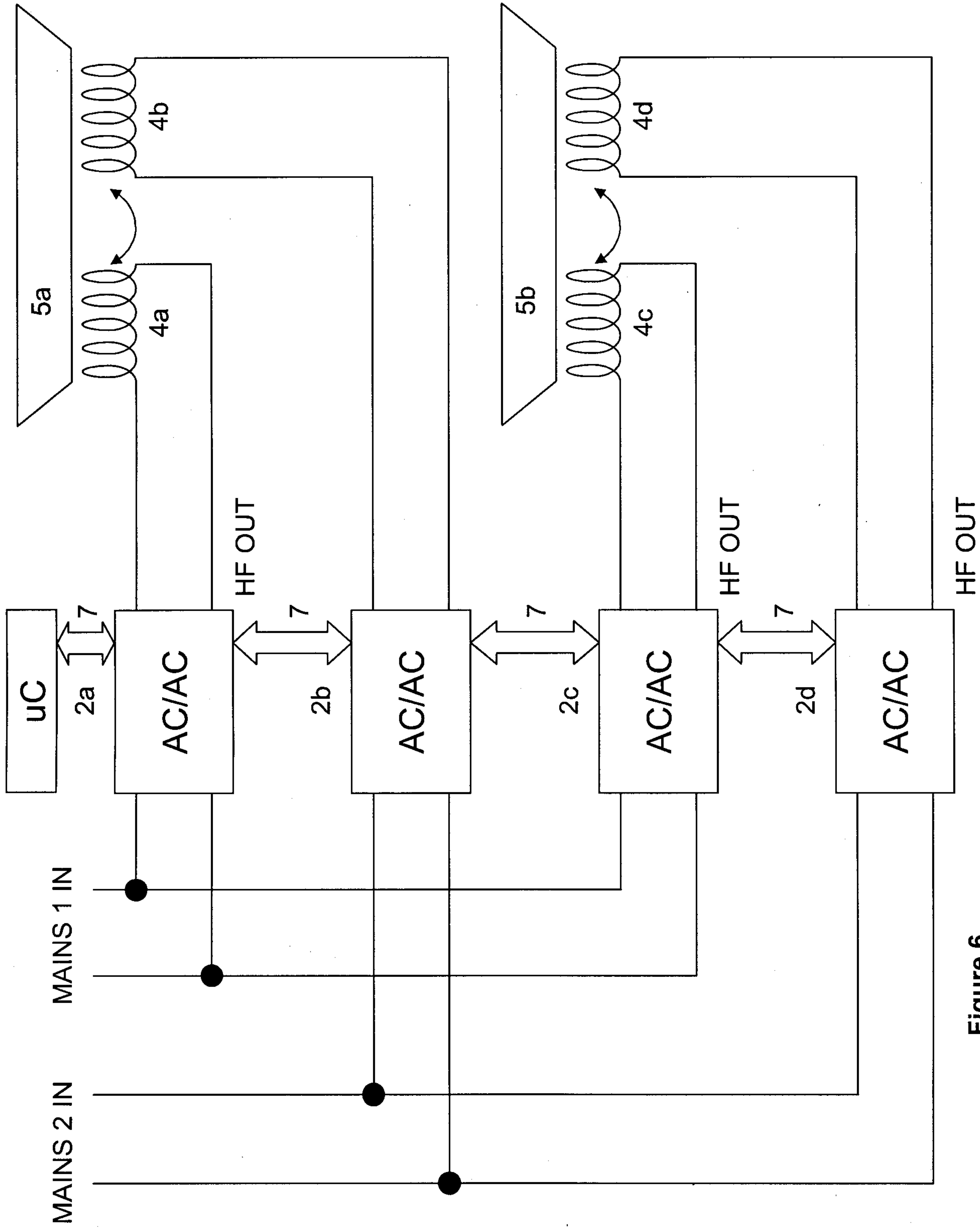

Figure 6

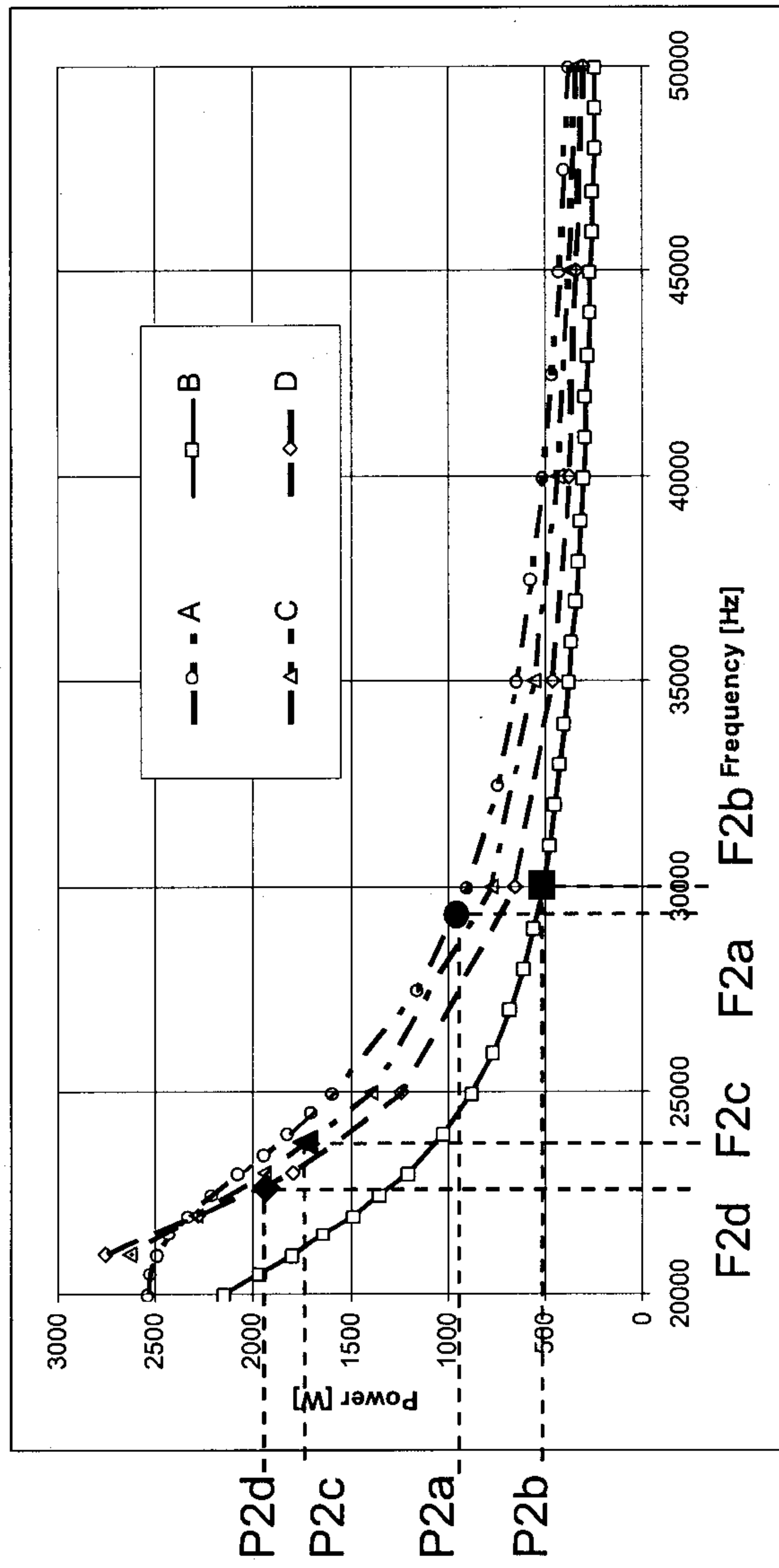
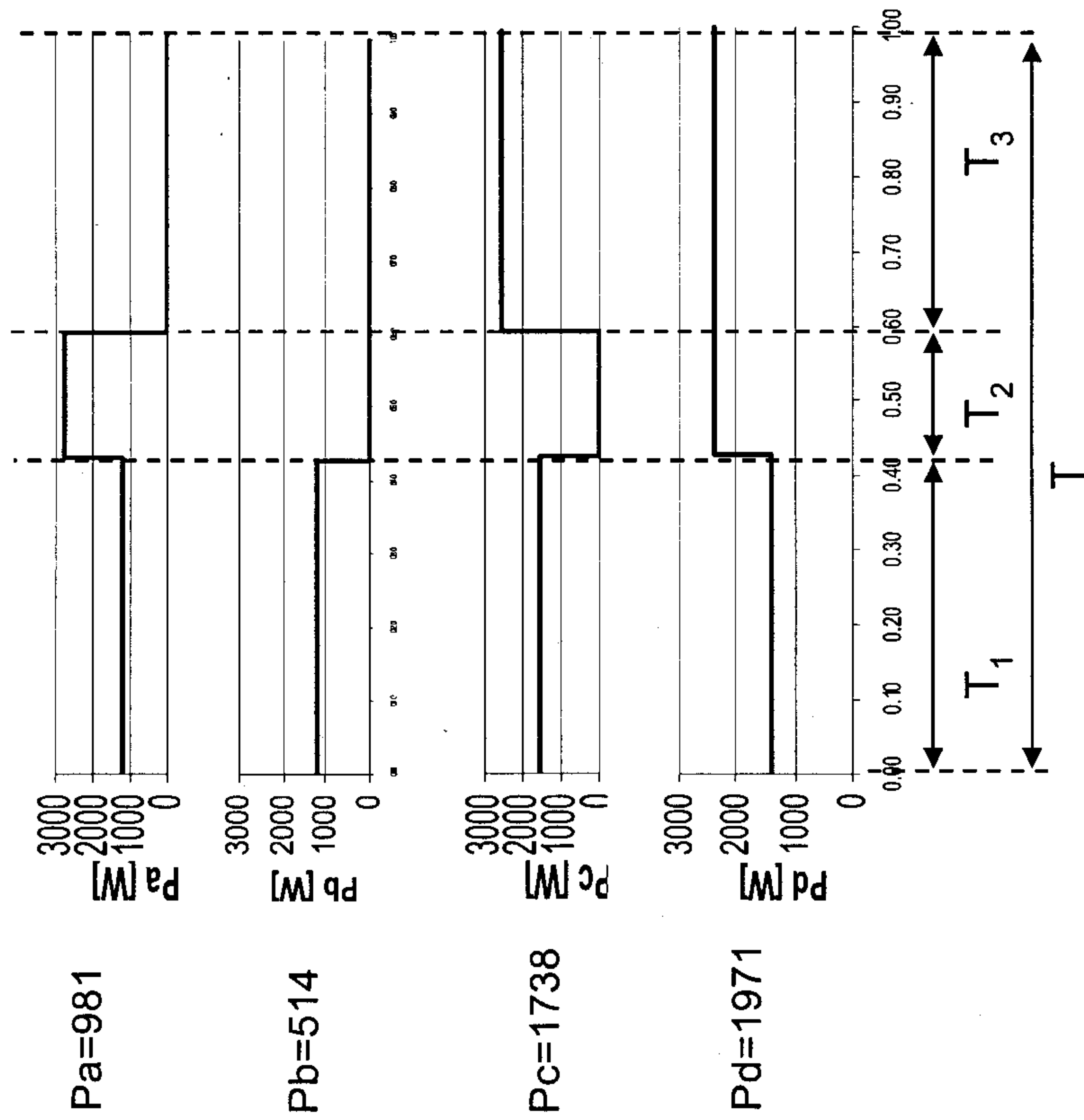

Figure 7



$$\sum_i T_i = T \quad \bar{P}_x = \sum_i P_{x_i} * \frac{T_i}{T}$$

Figure 8a

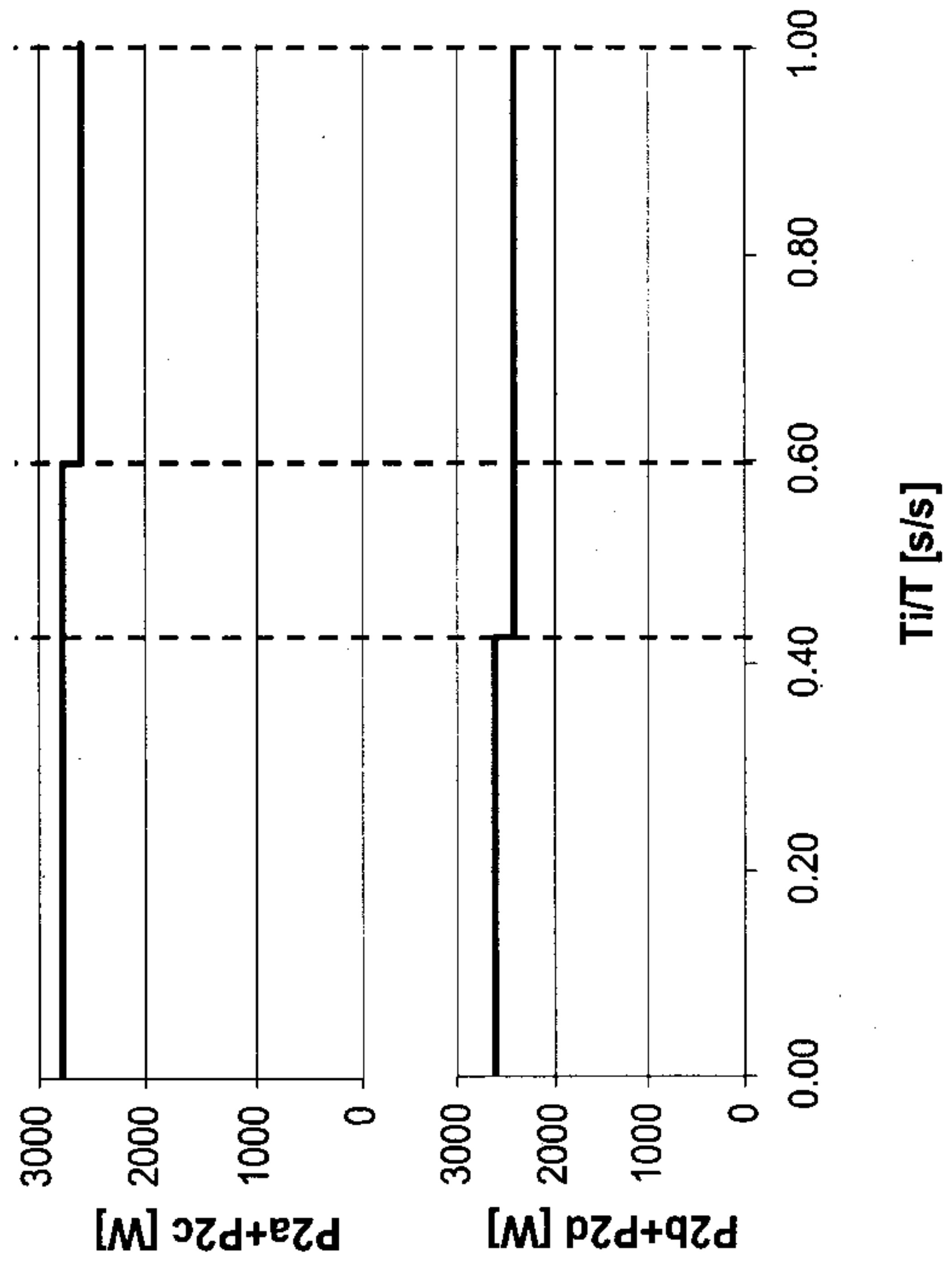

Figure 8b

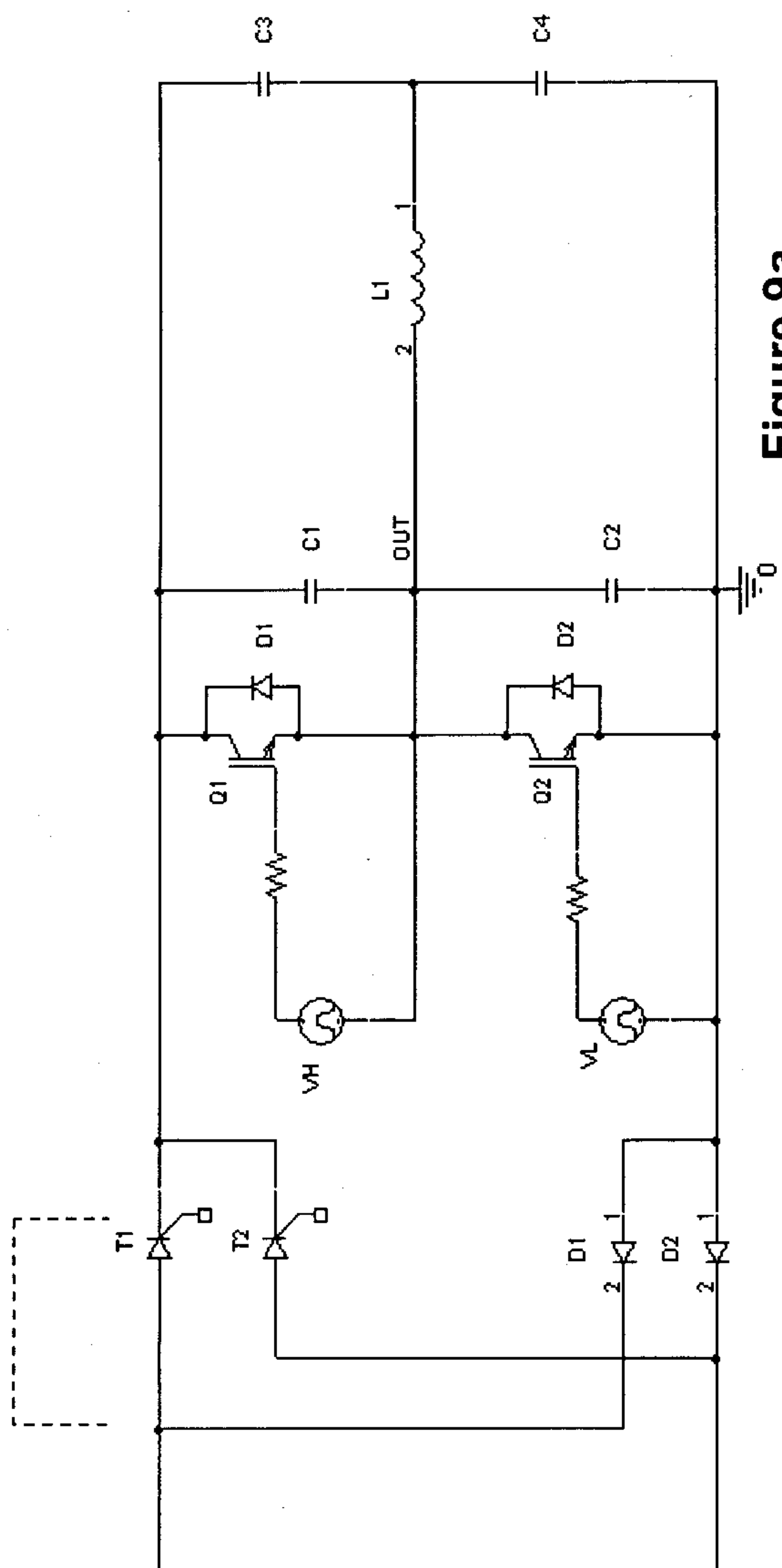

Figure 9a

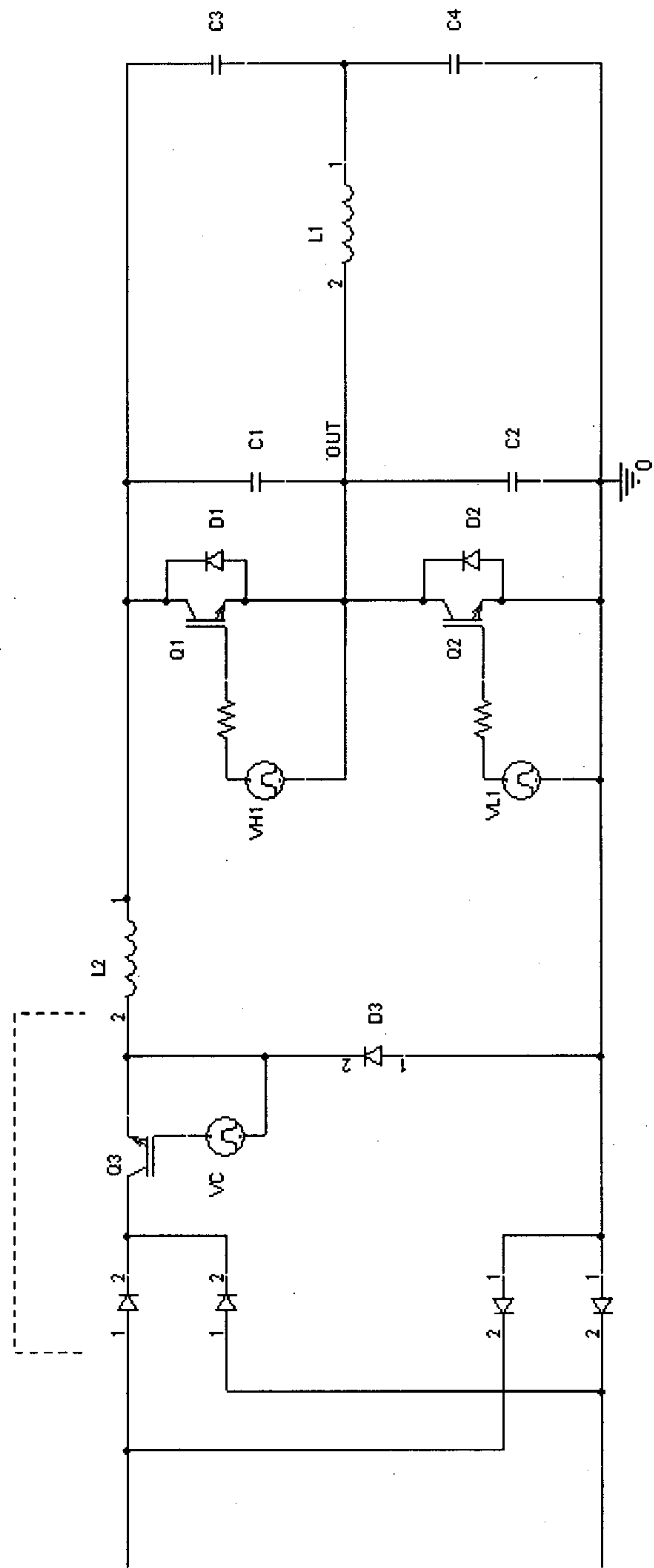

Figure 9b

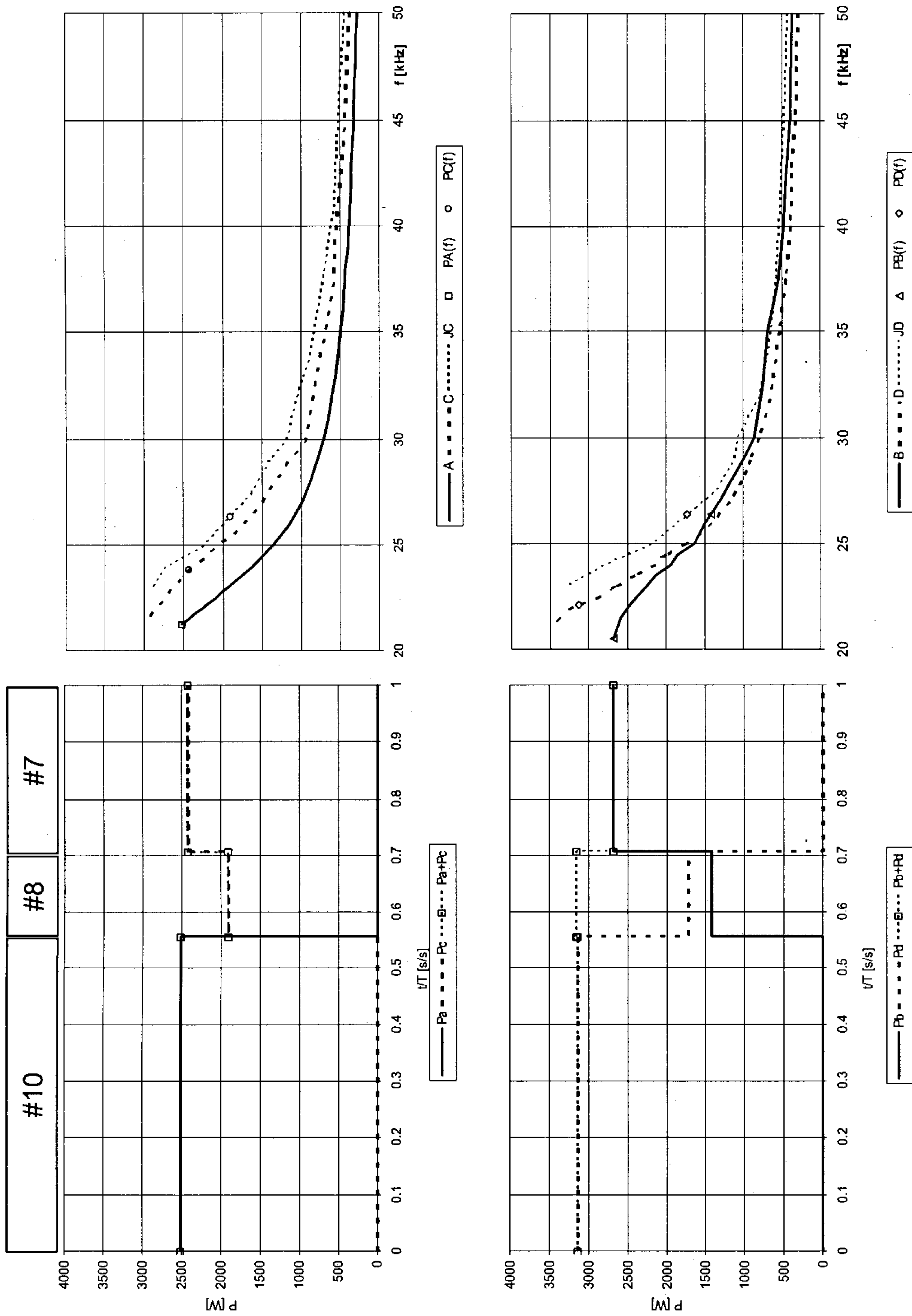

Figure 10

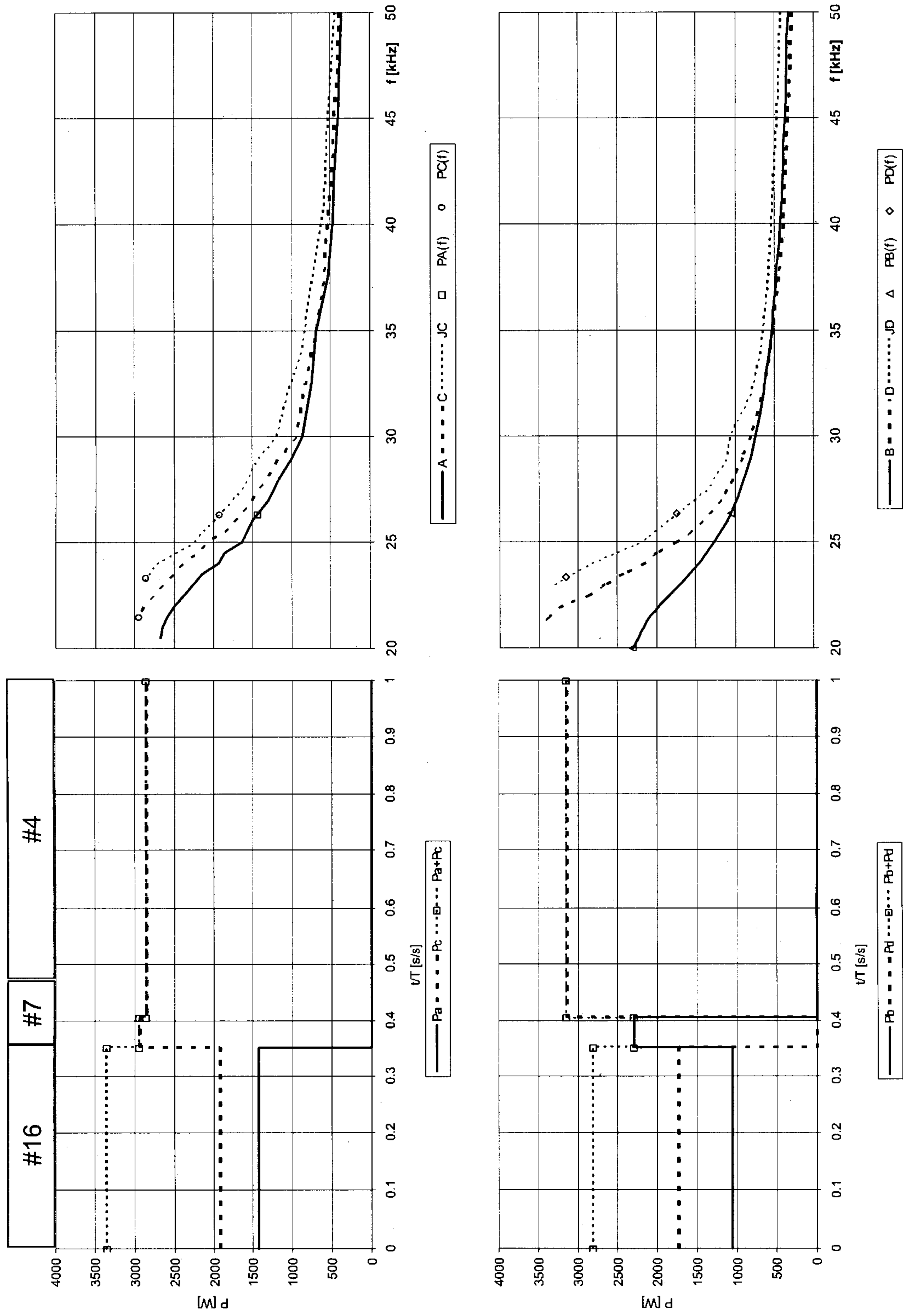

Figure 11

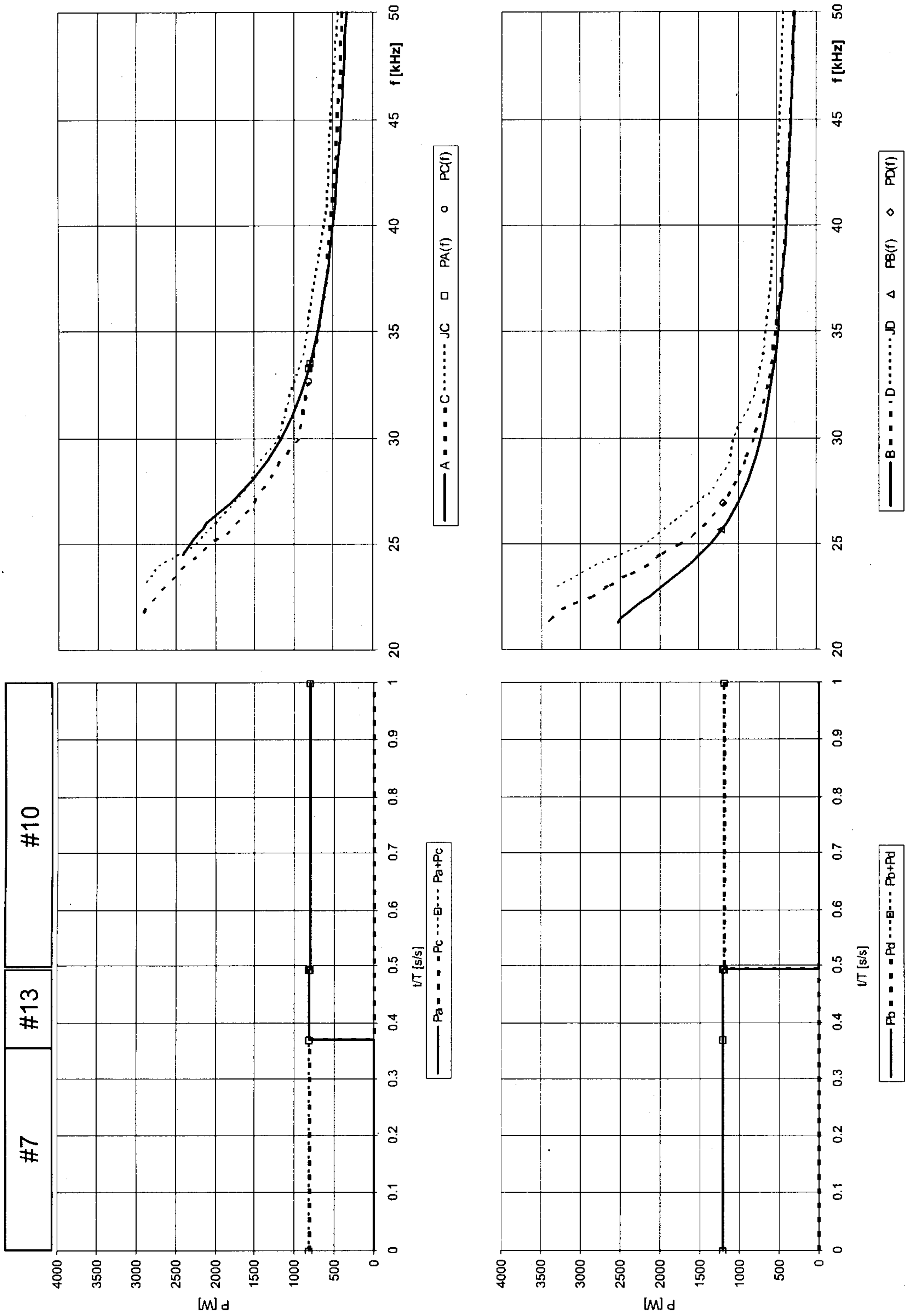

Figure 12

