

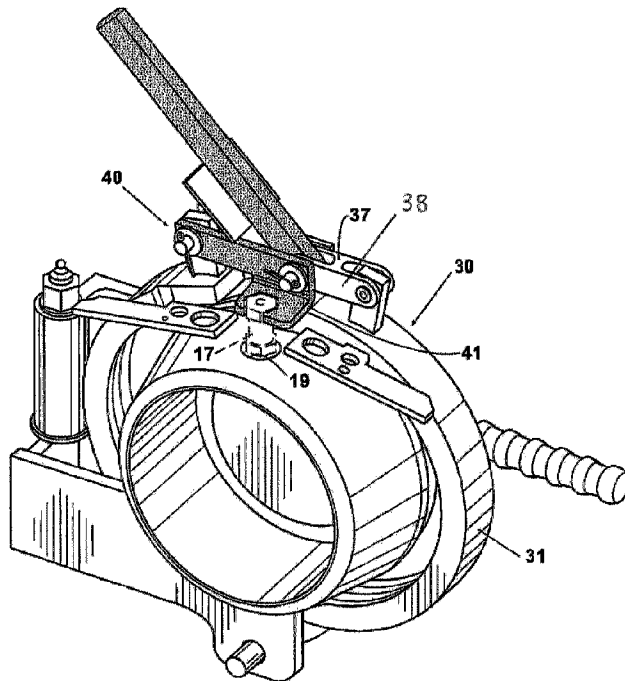


(86) Date de dépôt PCT/PCT Filing Date: 2019/06/05  
 (87) Date publication PCT/PCT Publication Date: 2019/12/12  
 (45) Date de délivrance/Issue Date: 2023/09/19  
 (85) Entrée phase nationale/National Entry: 2020/09/01  
 (86) N° demande PCT/PCT Application No.: US 2019/035559  
 (87) N° publication PCT/PCT Publication No.: 2019/236691  
 (30) Priorité/Priority: 2018/06/05 (US62/680,801)

(51) Cl.Int./Int.Cl. *F16J 13/10* (2006.01),  
*F16J 13/18* (2006.01), *F16J 13/24* (2006.01)  
 (72) Inventeurs/Inventors:  
 MITCHELL, JOSHUA, US;  
 KEENAN, WILLIAM, US;  
 TEFFT, WILLIAM, US;  
 MORTON, JOSEPH ALAN, US;  
 RITCHIE, AARON M., US;  
 HENDRICKS, ROBERT FULTON, US;  
 BOEHNING, SAMUEL R., US  
 (73) Propriétaire/Owner:  
 TDW DELAWARE, INC., US  
 (74) Agent: RIDOUT & MAYBEE LLP

(54) Titre : DISPOSITIF DE FERMETURE DE RECIPIENT AVEC MOYEN DE DETECTION DE DEFAILLANCE A SECURITE INTEGREE

(54) Title: VESSEL CLOSURE DEVICE WITH FAIL SAFE FAILURE DETECTION MEANS



(57) **Abrégé/Abstract:**

A closure [10] for a cylindrical vessel includes at least one holding means [30] configured to move the closure into a fully closed state, the holding means having a predetermined actuation force or torque to properly close the closure, the closure including one or both of the following failsafe failure detection features: a mechanical fuse [20] having a predetermined load failure force below that of a load failure force of at least one component of the holding means and above that of a predetermined actuation force or torque to properly close the closure; or a block [40] sized to at least partially overlap a pressure warning lock hole [19] of the closure door when the closure is not in the fully closed state and to fully expose the pressure warning lock hole when the closure is in the fully closed state, thereby permitting insertion of a pressure warning lock [17].

## (12) INTERNATIONAL APPLICATION PUBLISHED UNDER THE PATENT COOPERATION TREATY (PCT)

(19) World Intellectual Property  
Organization  
International Bureau

(43) International Publication Date  
12 December 2019 (12.12.2019)



(10) International Publication Number  
**WO 2019/236691 A1**

## (51) International Patent Classification:

*F16J 13/10* (2006.01)      *F16J 13/24* (2006.01)  
*F16J 13/18* (2006.01)

## (21) International Application Number:

PCT/US2019/035559

## (22) International Filing Date:

05 June 2019 (05.06.2019)

## (25) Filing Language:

English

## (26) Publication Language:

English

## (30) Priority Data:

62/680,801      05 June 2018 (05.06.2018)      US

(71) Applicant: **TDW DELAWARE, INC.** [US/US]; Suite 780, 1100 Market Street, Wilmington, DE 19801 (US).

(72) Inventors: **MITCHELL, Joshua**; 1316 South Juniper Avenue, Broken Arrow, OK 74012 (US). **KEENAN, William**; 12515 East 134th Street South, Broken Arrow, OK 74011 (US). **TEFFT, William**; 14505 East Quail Run, Claremore, OK 74017 (US). **MORTON, Joseph, Alan**; 5803 East 18th Street, Tulsa, OK 74112 (US). **RITCHIE, Aaron, M.**; 6207 East 91st Place, Tulsa, OK 74137 (US). **HENDRICKS, Robert, Fulton**; 3483 East 51st Place, Tulsa, OK 74135

(US). **BOEHNING, Samuel, R.**; 1916 East 13th Street, Tulsa, OK 74104 (US).

(74) Agent: **ROSSLER, Paul, E.**; Gablegotwals, 100 West 5th Street, Tulsa, OK 74103 (US).

(81) Designated States (*unless otherwise indicated, for every kind of national protection available*): AE, AG, AL, AM, AO, AT, AU, AZ, BA, BB, BG, BH, BN, BR, BW, BY, BZ, CA, CH, CL, CN, CO, CR, CU, CZ, DE, DJ, DK, DM, DO, DZ, EC, EE, EG, ES, FI, GB, GD, GE, GH, GM, GT, HN, HR, HU, ID, IL, IN, IR, IS, JO, JP, KE, KG, KH, KN, KP, KR, KW, KZ, LA, LC, LK, LR, LS, LU, LY, MA, MD, ME, MG, MK, MN, MW, MX, MY, MZ, NA, NG, NI, NO, NZ, OM, PA, PE, PG, PH, PL, PT, QA, RO, RS, RU, RW, SA, SC, SD, SE, SG, SK, SL, SM, ST, SV, SY, TH, TJ, TM, TN, TR, TT, TZ, UA, UG, US, UZ, VC, VN, ZA, ZM, ZW.

(84) Designated States (*unless otherwise indicated, for every kind of regional protection available*): ARIPO (BW, GH, GM, KE, LR, LS, MW, MZ, NA, RW, SD, SL, ST, SZ, TZ, UG, ZM, ZW), Eurasian (AM, AZ, BY, KG, KZ, RU, TJ, TM), European (AL, AT, BE, BG, CH, CY, CZ, DE, DK, EE, ES, FI, FR, GB, GR, HR, HU, IE, IS, IT, LT, LU, LV, MC, MK, MT, NL, NO, PL, PT, RO, RS, SE, SI, SK, SM, TR), OAPI (BF, BJ, CF, CG, CI, CM, GA, GN, GQ, GW, KM, ML, MR, NE, SN, TD, TG).

(54) Title: VESSEL CLOSURE DEVICE WITH FAIL SAFE FAILURE DETECTION MEANS

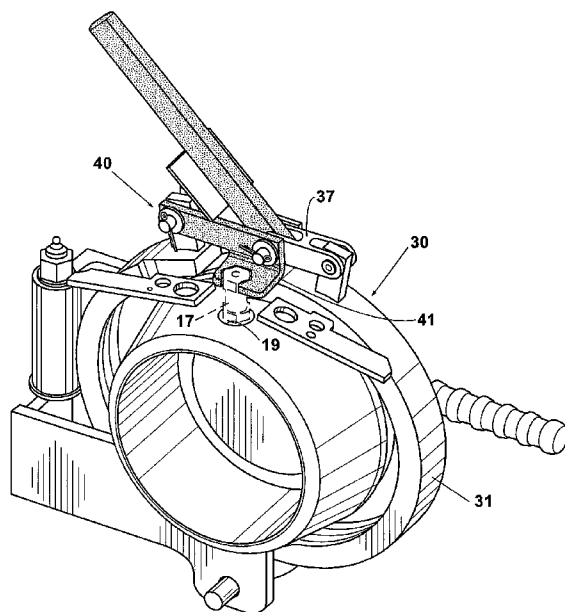


Fig. 6

(57) Abstract: A closure [10] for a cylindrical vessel includes at least one holding means [30] configured to move the closure into a fully closed state, the holding means having a predetermined actuation force or torque to properly close the closure, the closure including one or both of the following failsafe failure detection features: a mechanical fuse [20] having a predetermined load failure force below that of a load failure force of at least one component of the holding means and above that of a predetermined actuation force or torque to properly close the closure; or a block [40] sized to at least partially overlap a pressure warning lock hole [19] of the closure door when the closure is not in the fully closed state and to fully expose the pressure warning lock hole when the closure is in the fully closed state, thereby permitting insertion of a pressure warning lock [17].



WO 2019/236691 A1

**WO 2019/236691 A1** 

---

**Published:**

— *with international search report (Art. 21(3))*

## VESSEL CLOSURE DEVICE WITH FAIL SAFE FAILURE DETECTION MEANS

This application claims priority to US 62/680,801 filed June 5, 2018.

### BACKGROUND

This disclosure is in the field of pipeline and vessel closures like those used, for example,  
5 to provide access to a pig trap during launch and recovery operations.

By way of example, a pig trap includes a collar adapted to be attached to an end of a pipe,  
a door for opening and closing the end of the pipe, means for holding the door to the collar, and  
means for sealing the door to the collar when the door is held to the collar. The holding means may  
include segmented plates that expand inside the collar barrel or clamps that hold the door against  
10 the barrel. US 4,237,936 to Lollis *et al.* provides an example of a closure that makes use of clamps.

### SUMMARY

Embodiments of a closure for a cylindrical vessel includes at least one holding means  
configured to move the closure into a fully closed state, the holding means having a predetermined  
actuation force or torque to properly close the closure, the closure including one or both of the  
15 following failsafe failure detection features:

a mechanical fuse having a predetermined load failure force below that of a load failure  
force of at least one component of the holding means and above that of the  
predetermined actuation force or torque; or

a block sized to at least partially overlap a pressure warning lock hole of the closure door  
20 when the closure is not in the fully closed state and to fully expose the pressure  
warning lock hole when the closure is in the fully closed state.

The holding means move between an unactuated or open position and an actuated or fully closed position. In embodiments, the holding means may include a pair of clamp rings arranged about a door of the closure so as to hold the door in a closed and sealed condition. The predetermined actuation force is above the weight of the clamp rings.

## 5 BRIEF DESCRIPTION OF THE DRAWINGS

FIG. 1 is an isometric view of a prior art closure with holding means properly closing the closure in a fully closed state. The holding means include a handle with a linkage connected to clamp rings.

10 FIG. 2 is the prior art closure of FIG. 1, illustrating blockage or debris in a bottom portion of the closure prior to actuation of the holding means. None of the pins "P" that hold the closure together are designed as a weak link.

FIG. 3 is an isometric view of an embodiment of a closure of this disclosure including a mechanical fuse capable of preventing a failure of at least one other component of the closure when there is blockage or debris or where excessive force is required to properly close the closure.

15 FIG. 4 is an enlarged cross section view of the mechanical fuse of FIG. 3.

FIG. 5 is a rear isometric view of a prior art closure and illustrating a pressure warning lock. It may be possible to install the pressure warning lock without the holding means being properly closed.

20 FIG. 6 is a rear isometric view of an embodiment of a closure of this disclosure including a block that prevents the pressure warning lock from being inserted when the closure is not in a fully closed state. The block may be a bracket sized to at least partially cover the pressure warning lock hole when the holding means have not been fully actuated to properly close the closure. The block is illustrated to show the interference with the pressure warning lock, which cannot be

inserted into the pressure warning lock hole, until the closure is fully closed and the block clears the pressure warning lock hole.

FIG. 7 is an enlarged view of the block of FIG. 6.

FIG. 8 is a rear isometric view of an embodiment of a closure of this disclosure including  
5 a ratchet-style closing mechanism and a block. The block may include an extended plate that at least partially covers the pressure warning lock hole when the closure is not yet properly closed. The plate is illustrated to show the interference with the pressure warning lock.

FIG. 9 is an enlarged view of the block of FIG. 8.

#### **DETAILED DESCRIPTION**

10 Embodiments of a closure include a mechanical fuse, a pressure warning lock block, or a combination of the mechanical fuse and the pressure warning lock block. The embodiments may be adapted to a closure the same or similar to that as disclosed in US 4,237,936 to Lollis *et al.* or US 4,515,287 to Baudoux *et al.*

Referring first to FIGS. 3 & 4, in embodiments of this disclosure a closure 10 includes at  
15 least one mechanical fuse 20 having a predetermined load failure force below that of a load failure force of at least one component of holding means 30 of the closure and above that of a force to provide a predetermined actuation force or torque to overcome the holding means 30. In some embodiments the mechanical fuse 20 includes a shear pin 21 or its equivalent. The holding means 30 may include one or more clamp rings 31. A handle 33 may be connected to the clamp rings 31  
20 by corresponding lugs 35, at least one of which includes the mechanical fuse 20.

The load failure force of the mechanical fuse 20 is above the predetermined actuation force of the holding means 30 to properly close the closure 10 into a fully closed position but below that of load failure force of another component of the holding means 30. In embodiments, the other

component may be a welded component such as, but not limited to, the lugs 35. The predetermined actuation force may be a force to overcome the weight of the holding means 30. The holding means 30 may include a pair of clamp rings 31, the predetermined actuation force being above a weight of the pair of clamp rings 31.

5           In embodiments, the mechanical fuse 20 may be located on a top end or portion 11 of the closure 10 so as to be visible to an operator. In some embodiments, the mechanical fuse 10 may be located on the top end 11 of the closure 10 in proximity to a pressure warning lock 17. Where the holding means 30 include clamp rings 31, a common pivot point 37 (*e.g.* a pin or its equivalent) of the clamp rings 31 may be located toward a bottom end or portion 15 of the closure. When  
10 blockage or debris “B” in a bottom portion 15 of the closure 10 causes an increase in force to be applied to actuate the holding means 30 during closure (but still below the failure force of another component such as the common pivot point 37), the mechanical fuse 20 fails. The failed mechanical fuse 20 may be easily detectable and visible to an operator. The planned failure of the fuse 20 protects at least one other component of the closure from failing due to excessive force  
15 required to close the holding means 30.

Referring now to FIGS. 6 & 7, in embodiments of a closure 10 of this disclosure, a block 40 interferes with a pressure warning lock 17, thereby preventing insertion or installation of the lock 17 into the pressure warning lock hole 19 when the closure 10 is opened or not in a fully closed state. The block 40 is a bracket 41 connected to the pair of clamp rings 31 by way of linkage  
20 38 (which, in turn, is connected to the lugs 35 of the clamp rings 31). The bracket 41 includes an upper arm 41a that runs parallel to the linkage 38 and a lower arm or flange 41b that runs perpendicular to it. The upper arm 41a is longer than the lower arm 41b in a longitudinal direction, the lower arm 41b being longer than the upper arm 41a in a lateral direction. The block 40 may be

sized so that when the closure 10 is in the fully closed state, the pressure warning lock 17 may be installed in the hole 19. The pressure warning lock 17 may include a pin 23. The holding means 30 may be actuated by a handle 33 or by a ratchet-style closing mechanism 51 of a kind known in the art. *See e.g.* FIGS. 8 & 9.

5 Referring now to FIGS. 8 & 9, in some embodiments the block 40 includes a bracket 41 connected to a linkage 38 of the holding means 30. In other embodiments, the bracket 41 may be at least one plate 43 that aligns the pressure warning lock 17 with the hole 19. The bracket 41 may include alignment means 39 at one end 41c for the pressure warning lock 17 and sized to overlap  
10 the pressure warning lock hole 19 at another end 41d. Unlike prior art closures, the plate 43 is extended in length so that when the holding means 30 are opened or not fully closed, the plate 43 at least partially covers the pressure warning lock hole 19 and prevents the pressure warning lock 17 from being inserted into the hole 19. When the holding means 30 are fully actuated and the closure 10 is properly closed, the hole 19 is fully exposed. In some embodiments, holding means 30 includes one or more clamp rings 31.

15 While embodiments of the closure have been described, the closure may be modified without departing from the scope of the following claims. The claims are entitled to the full range of equivalents to which recited element is entitled.

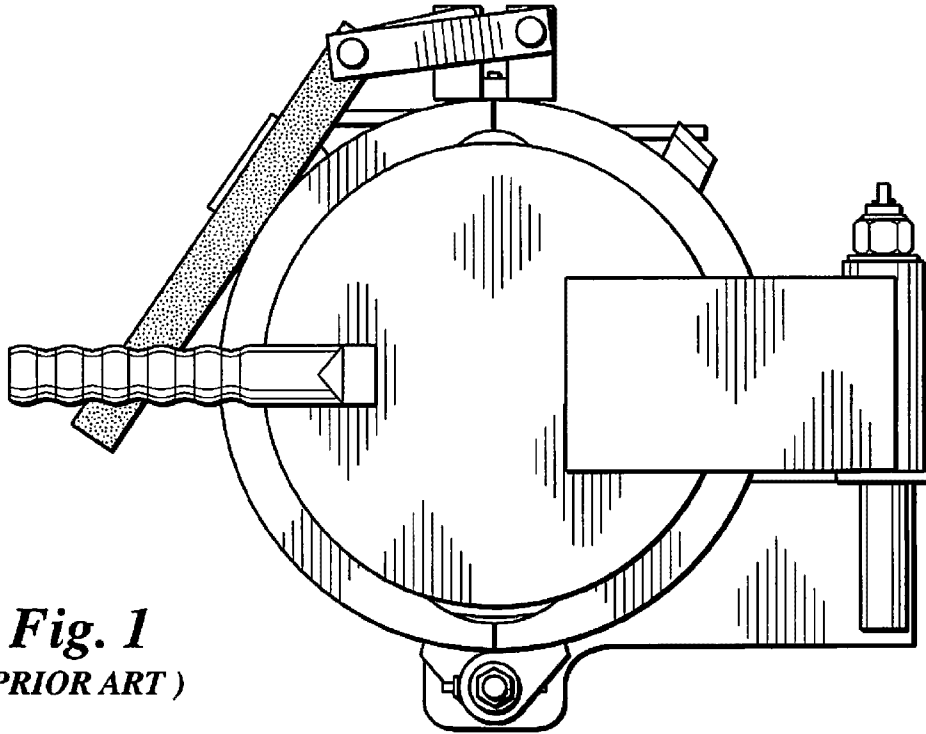
**CLAIMS**

1. A closure [10] for a cylindrical vessel, the closure comprising:  
holding means [30] for properly securing the closure in a fully closed state, the holding means having a predetermined actuation force; and at least one mechanical fuse [20] including a shear pin [21] in communication with the holding means; the shear pin [21] having a predetermined load failure force below that of a load failure force of another component of the closure and above that of the predetermined actuation force of the holding means, the another component of the closure selected from the group consisting of a lug [35] containing the shear pin and a pivot point [37] of the holding means.
2. A closure according to claim 1, the holding means including a handle [33].
3. A closure according to claim 1, the holding means including at least one pair of clamp rings [31].
4. A closure according to claim 3, the predetermined actuation force being above a weight of the at least one pair of clamp rings.

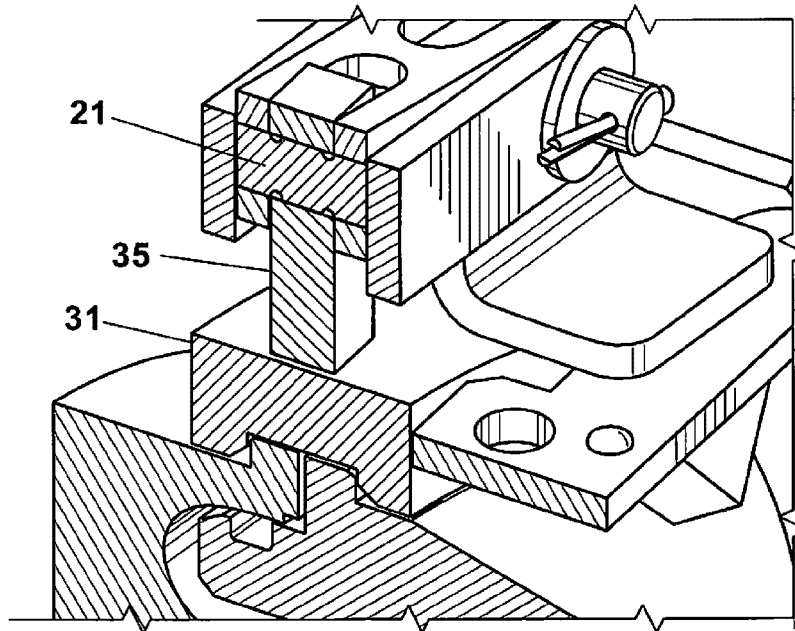
5. A closure according to claim 4, further comprising:
  - a pressure warning lock hole [19]; and
  - a block [40] connected to the at least one pair of clamp rings and sized to at least partially overlap the pressure warning lock hole when the closure is not in the fully closed state and to fully expose the pressure warning lock hole when the closure is in the fully closed state.
  
6. A closure [10] for a cylindrical vessel, the closure comprising:
  - holding means [30] for properly securing the closure in a fully closed state, the holding means including a pair of clamp rings [31] having a predetermined actuation force above a weight of the pair of clamp rings;
  - a pressure warning lock hole [19]; and
  - a block [40] connected to the pair of clamp rings and sized to at least partially overlap the pressure warning lock hole when the pair of clamp rings is not in the fully closed state and to fully expose the pressure warning lock hole when the pair of clamp rings is in the fully closed state.
  
7. A closure according to claim 6, the holding means including a linkage [38] connecting the pair of clamp rings, the block moving with the linkage and including a bracket [41] having an upper arm [41a] running parallel to the linkage and a lower arm running perpendicular to the linkage [41b].

8. A closure according to claim 6, the holding means including a linkage [38] connecting the pair of clamp rings, the block moving with the linkage and including a bracket [41] in a form of a plate [43] having one end [41c] that overlaps the pressure warning lock hole and another end [41d] containing alignment means [39] for a pressure warning lock.
9. A closure according to claim 8, the holding means including a handle [33].
10. A closure according to claim 9, the holding means including a ratchet mechanism [51].
11. A closure according to claim 6, further comprising:
  - at least one mechanical fuse [20] in communication with the holding means; the at least one mechanical fuse having a predetermined load failure force below that of a load failure force of another component of the closure and above that of the predetermined actuation force, the another component of the closure selected from the group consisting of a lug [35] containing the at least one mechanical fuse and a pivot point [37] of the holding means.
12. A closure according to claim 11, the at least one mechanical fuse being a shear pin [21].

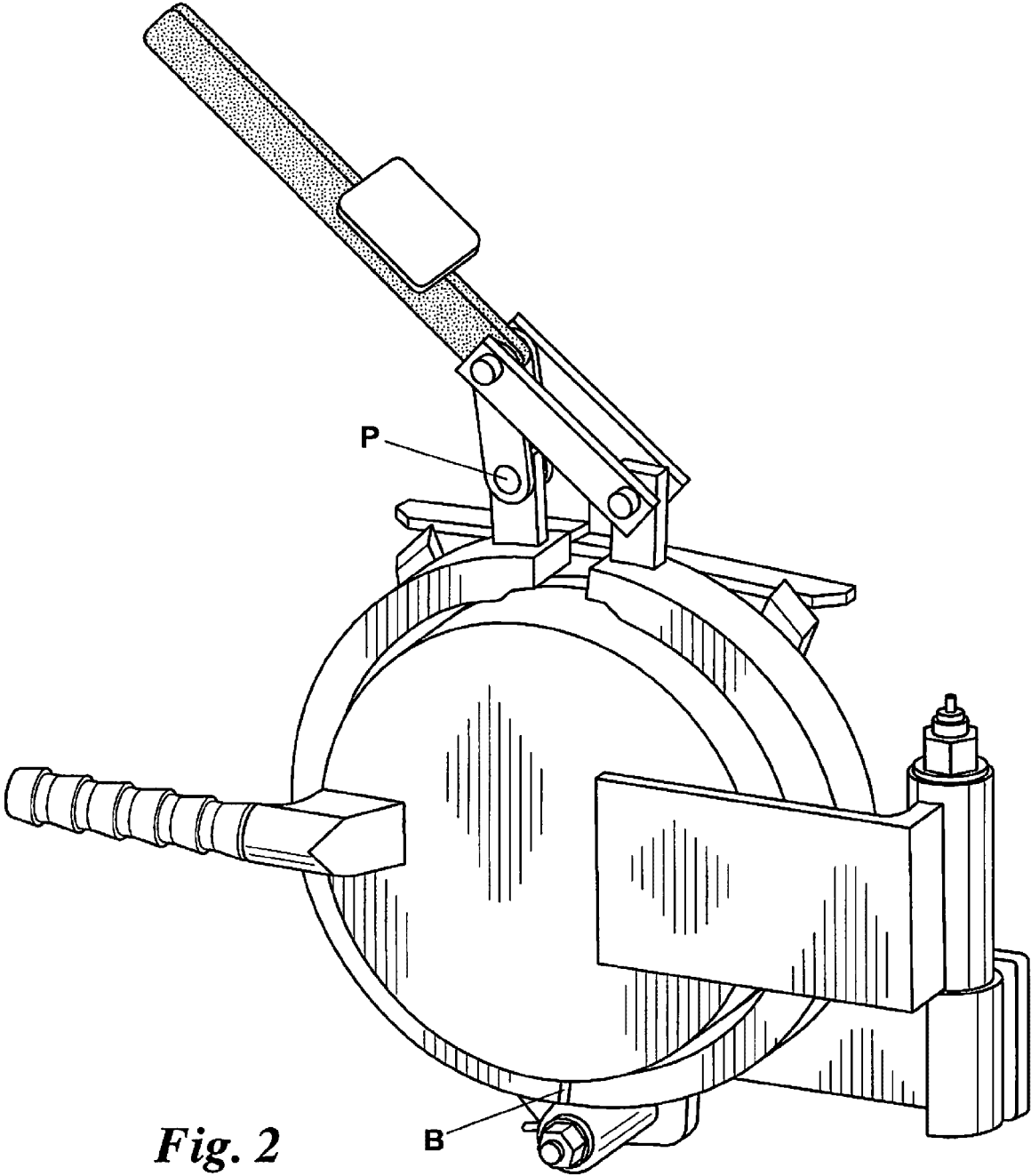
1/8



**Fig. 1**  
(PRIOR ART)

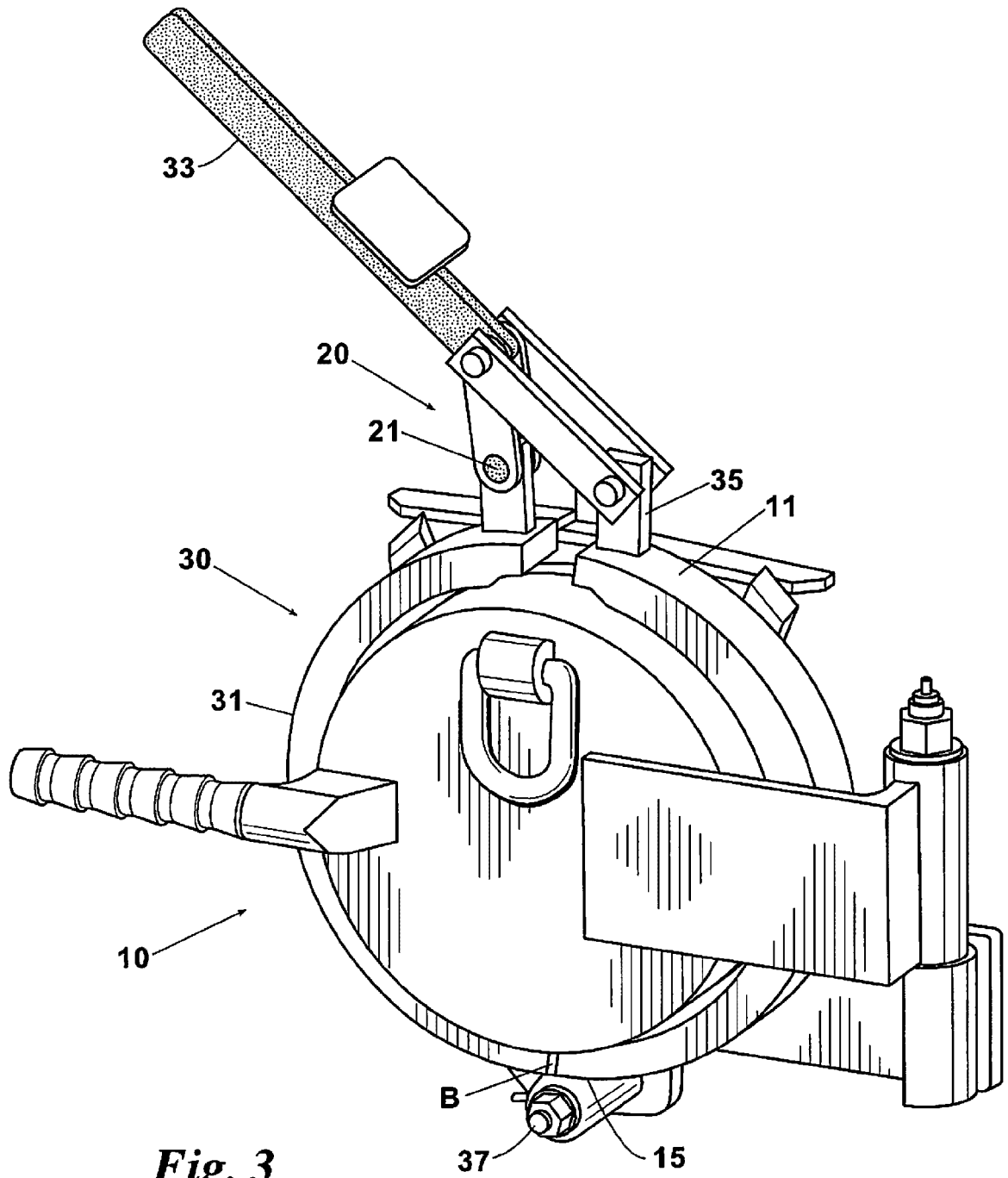


**Fig. 4**



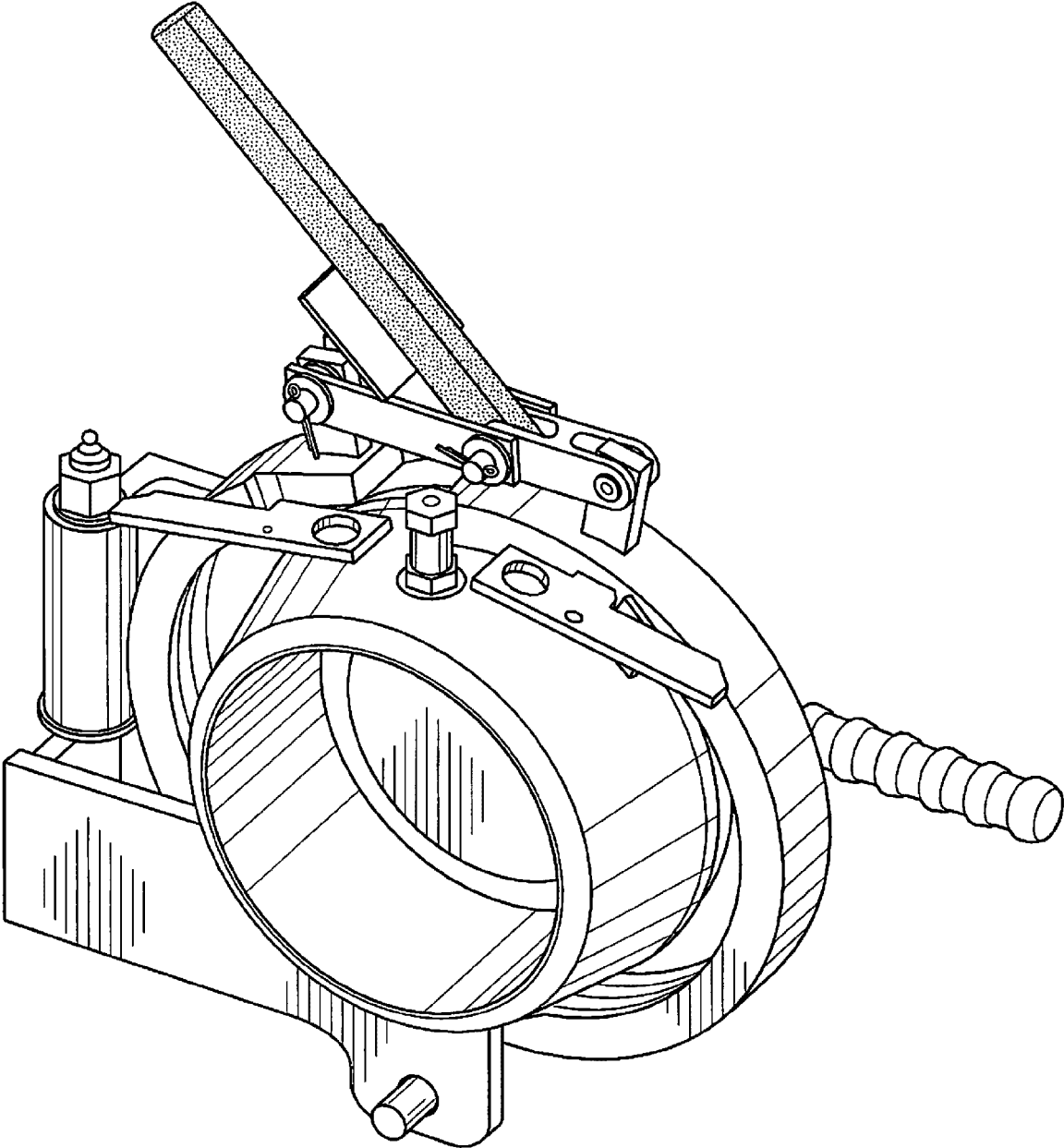
**Fig. 2**  
(PRIOR ART)

3/8

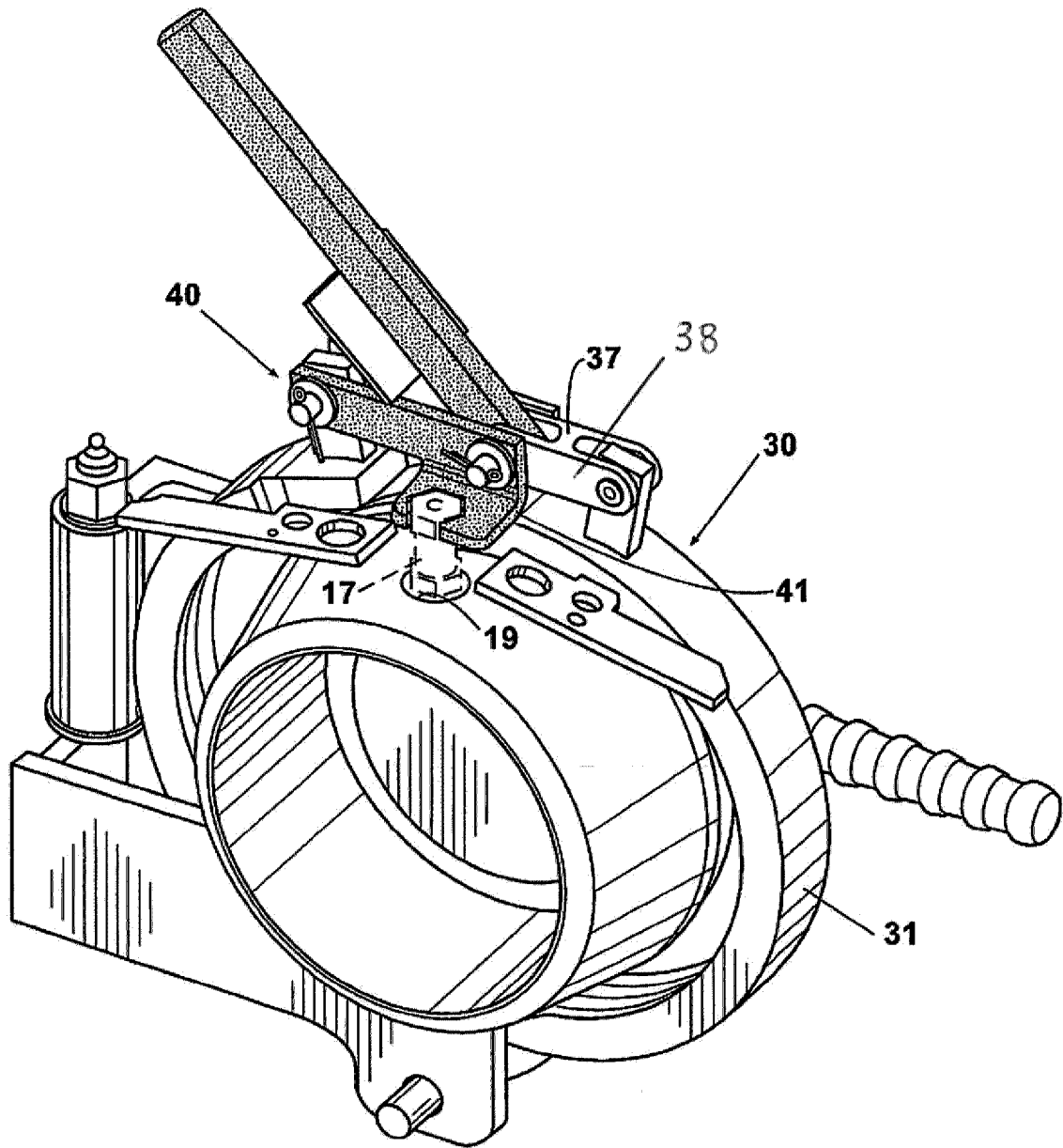


*Fig. 3*

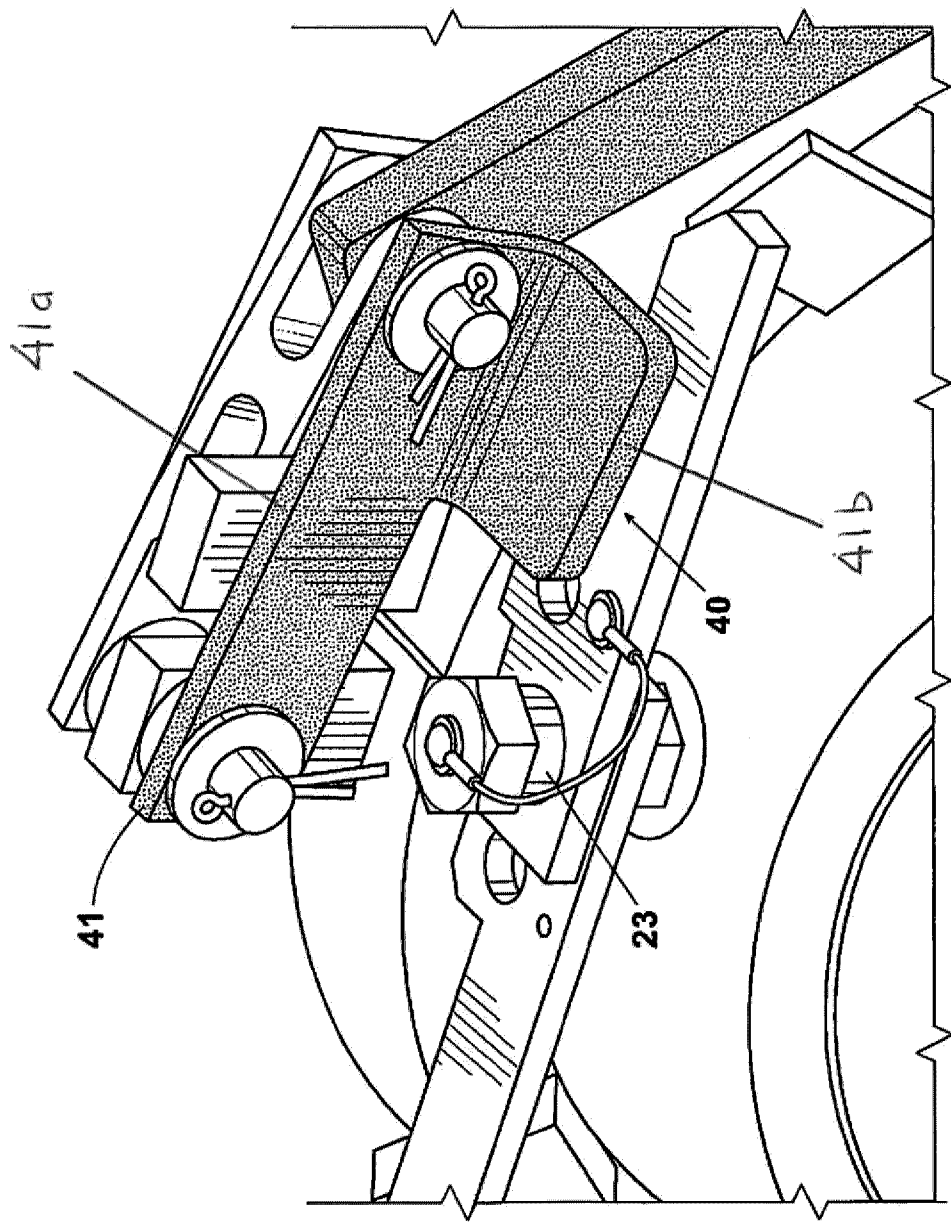
4/8



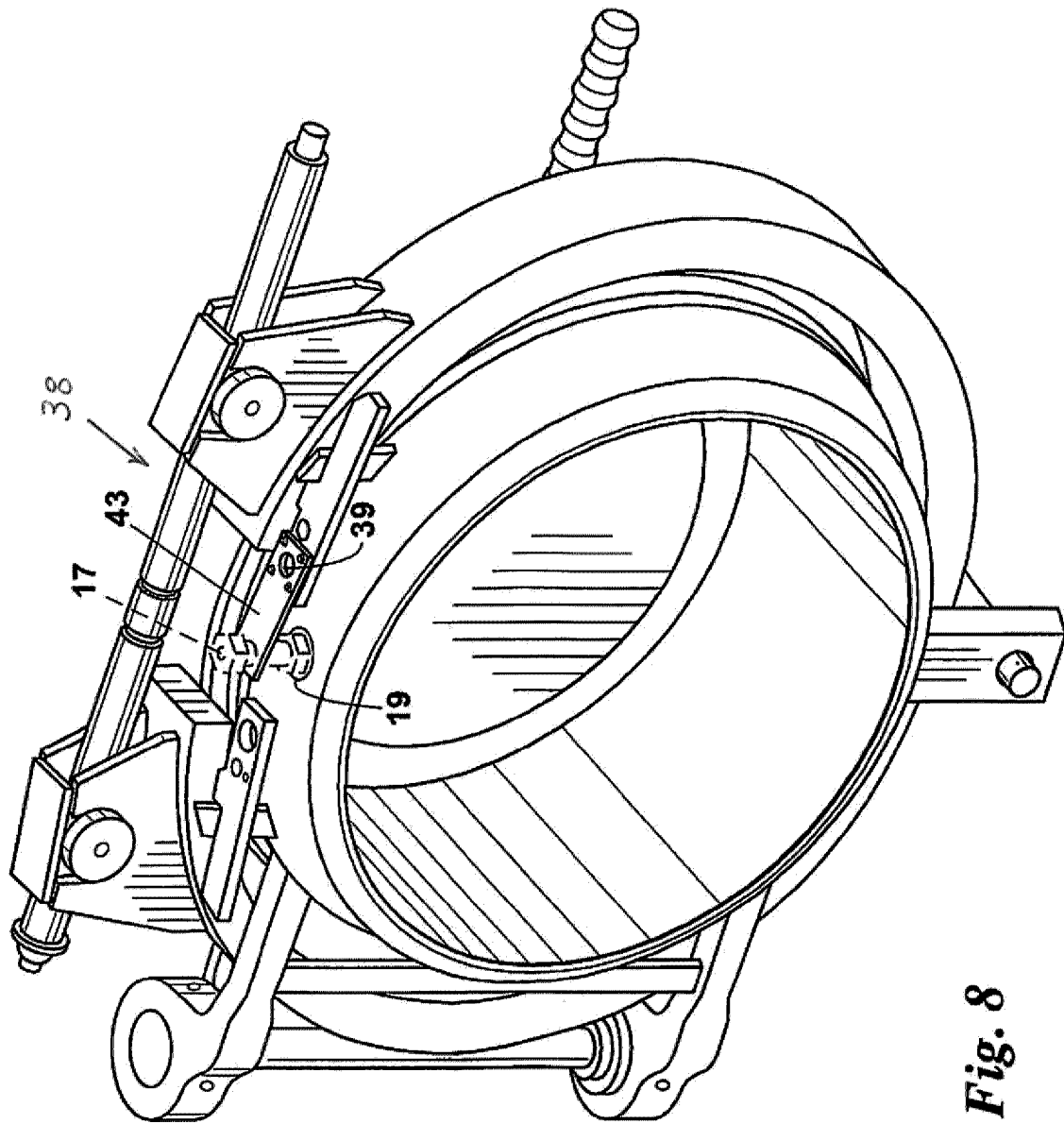
**Fig. 5**  
(PRIOR ART)



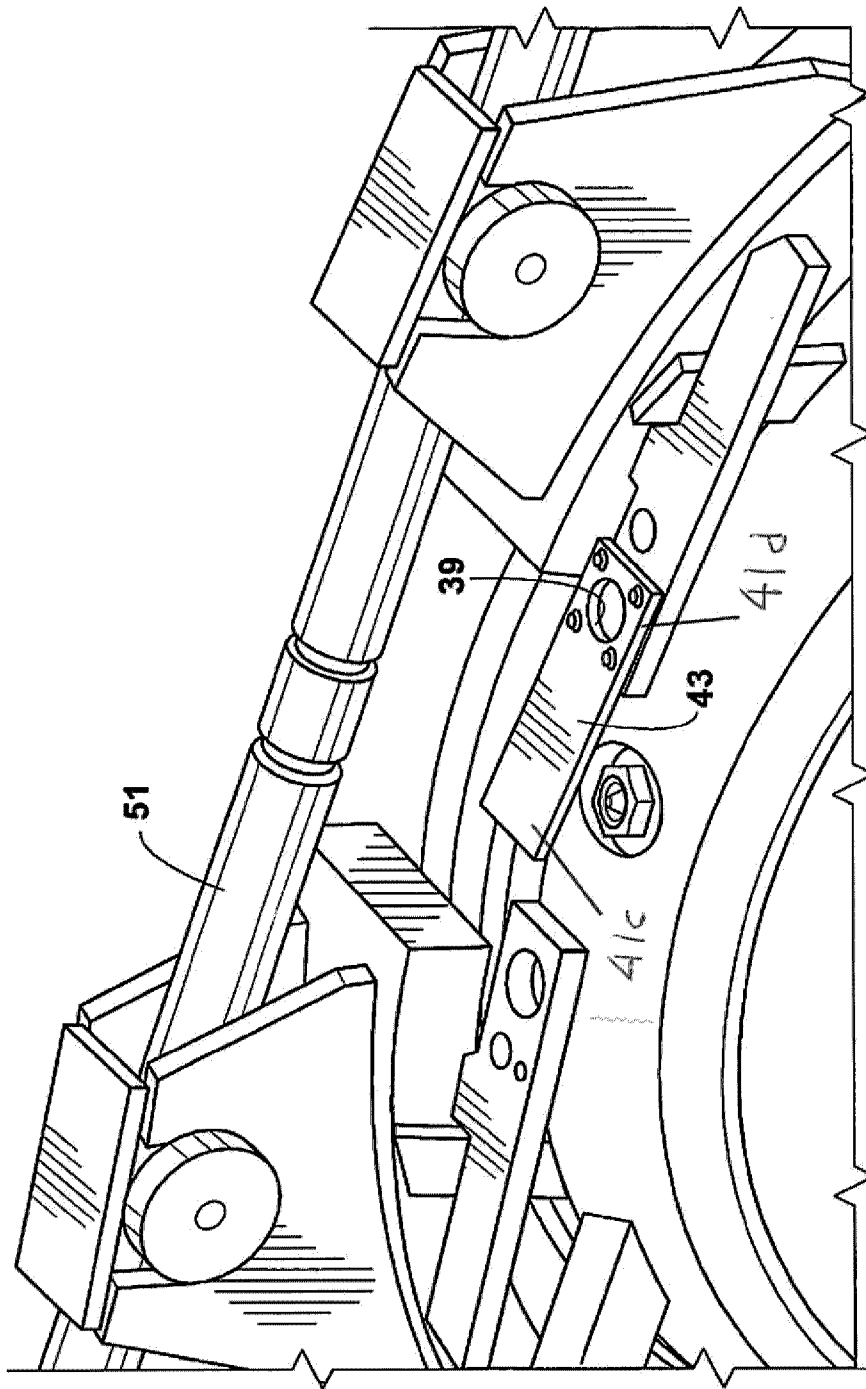
**Fig. 6**



**Fig. 7**



**Fig. 8**



**Fig. 9**

