

(No Model.)

M. ELSESSER.
COMPOUND ENGINE.

No. 251,198.

Patented Dec. 20, 1881.

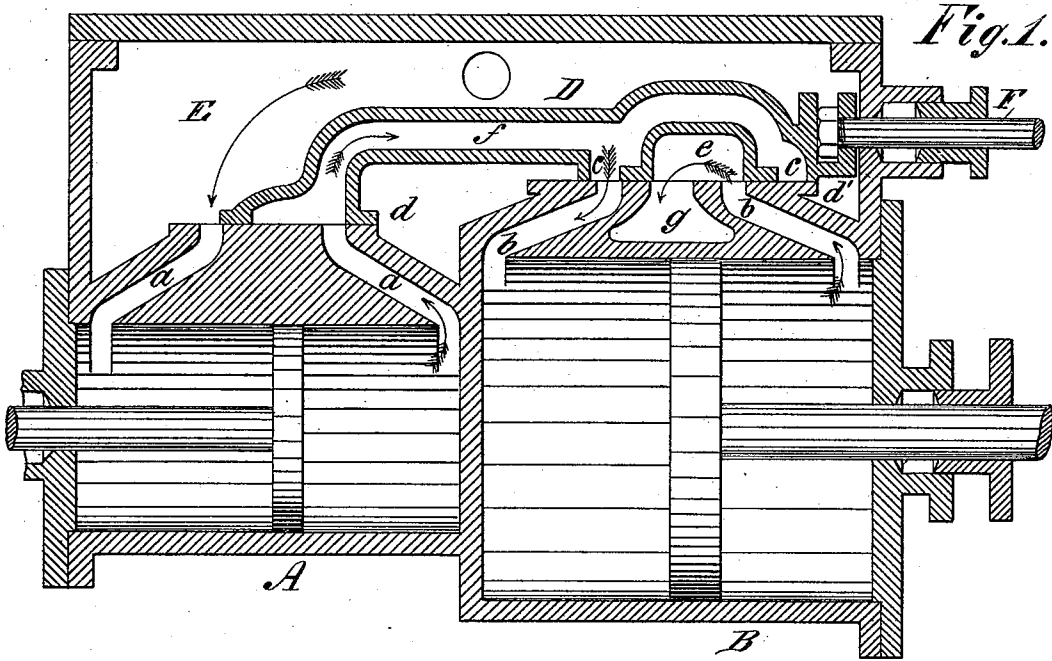
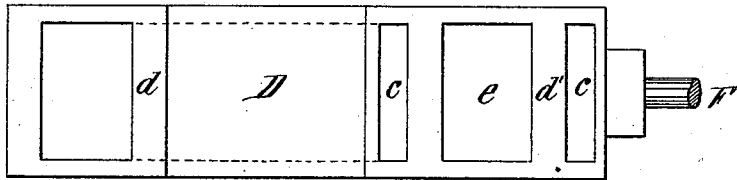

Fig. 2.



WITNESSES:

Theo. G. Washburn
C. Dequicken

INVENTOR:

M. Elssesser
BY *Munn & Co.*
ATTORNEYS.

UNITED STATES PATENT OFFICE.

MICHAEL ELSESSER, OF BROOKLYN, NEW YORK.

COMPOUND ENGINE.

SPECIFICATION forming part of Letters Patent No. 251,198, dated December 20, 1881.

Application filed May 26, 1881. (No model.)

To all whom it may concern:

Be it known that I, MICHAEL ELSESSER, of Brooklyn, in the county of Kings and State of New York, have invented certain useful Improvements in Compound Engines, of which
5 the following is a specification.

My invention relates to that class of steam-engines which have two cylinders, one larger than the other, the larger cylinder taking steam from the exhaust of the smaller or primary cylinder; and my invention has for its object to
10 simplify the engine, and such construction and arrangement of the cylinders and the valves thereof that the heat of the exhaust-steam in its transit from the primary to the secondary
15 cylinder shall not be unnecessarily reduced or lost, as heretofore.

The invention consists, principally, in forming the valves of the two cylinders integral and providing the same with a conduit for leading the exhaust-steam from the primary cylinder to the inlet-ports of the secondary cylinder and with an exhaust-passage for the steam from the secondary cylinder, the valves and
20 connecting-conduit being contained in the valve-chamber and entirely surrounded by steam from the boiler.

The invention also consists in the construction and arrangement of the cylinders, valves, and valve-chambers, as hereinafter fully described and claimed.
30

In the accompanying drawings, Figure 1 is a longitudinal vertical section of my invention, and Fig. 2 is a bottom view of the valve.

Similar letters of reference indicate corresponding parts.
35

A represents the primary cylinder, and B represents the secondary cylinder, which are arranged upon the same central line. The cylinder B is larger than the primary cylinder, and the valve-seat thereof is upon a higher level than that of the primary cylinder, and the sliding valve D is constructed so that the two faces *d d'* thereof are relatively arranged
40

to correspond with this difference in the elevation of the valve-seats. This valve D serves to admit steam and to cut off and permit the exhaust of the steam from both cylinders. It is formed with the broad opening *f'* and the conduit *f*, which leads from the ports *a a* of the primary cylinder to both ports *b b* of the secondary cylinder, through which conduit the exhaust-steam of the primary cylinder is conducted to and upon both sides of the piston-head in the secondary cylinder, by which exhaust-steam the secondary cylinder is operated.
45
50
55

Between the inlet-openings *c c* of the valve D is formed the exhaust-passage *e*, which communicates with the passage *g*, formed in the cylinder below the valve-seat and between the ports *b b*, through which passage the steam from the secondary cylinder passes to the open air or to a condenser. The valve D is entirely inclosed in the valve-chamber E, which extends over both cylinders, and the steam therein serves to prevent the loss of heat from the steam in its course through the conduit from the primary to the secondary cylinder, and results in economy of fuel. The valve is reciprocated by the rod F, attached to it, as shown in the drawings.
60
65
70

Having thus fully described my invention, I claim as new and desire to secure by Letters Patent—

1. In combination with the cylinders A and B, arranged upon the same central line, the double sliding valve D, formed with the conduit *f*, and the openings *c c*, leading from said conduit, substantially as and for the purposes specified.
75
80

2. The combination, with a valve chamber, E, and cylinders A B, of a valve provided with the openings *c c*, exhaust-passage *e*, and conduit *f*, as shown and described.

MICHAEL ELSESSER.

Witnesses:

C. SEDGWICK,
H. A. WEST.