

Nov. 26, 1935.

B. C. HERSCH

2,022,202

PUPILLOMETER

Filed Jan. 8, 1935

2 Sheets-Sheet 1

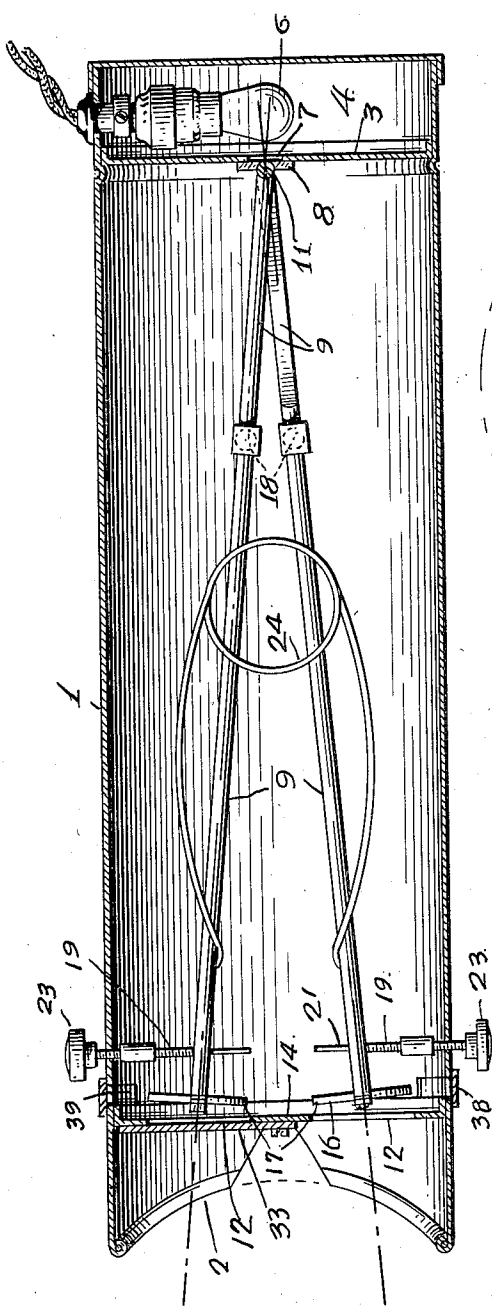

Fig. 1.

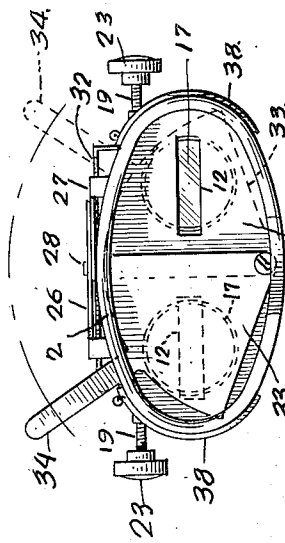

Fig. 3.

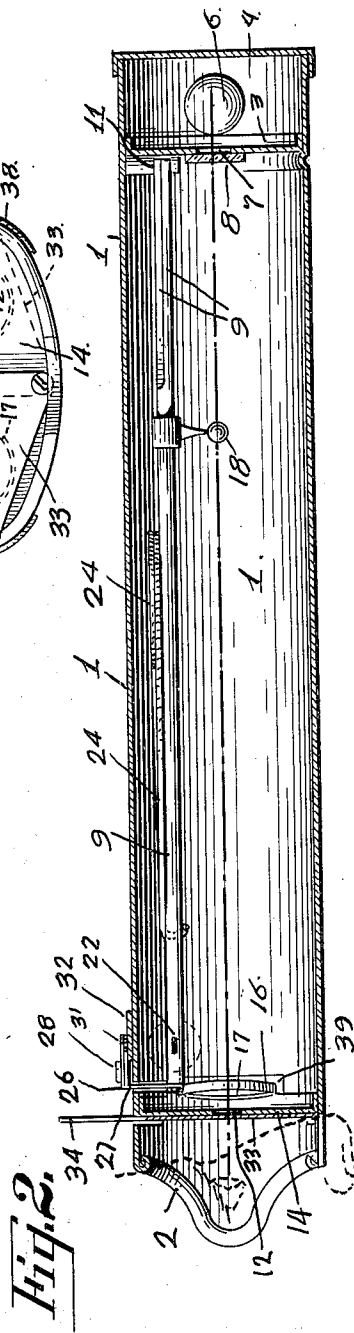

Fig. 2.

INVENTOR.
BERT C. HERSCH
By *Cuthbert L. Slee*,
HIS ATTORNEY.

Nov. 26, 1935.

B. C. HERSCH

2,022,202

PUPILLOMETER

Filed Jan. 8, 1935

2 Sheets-Sheet 2

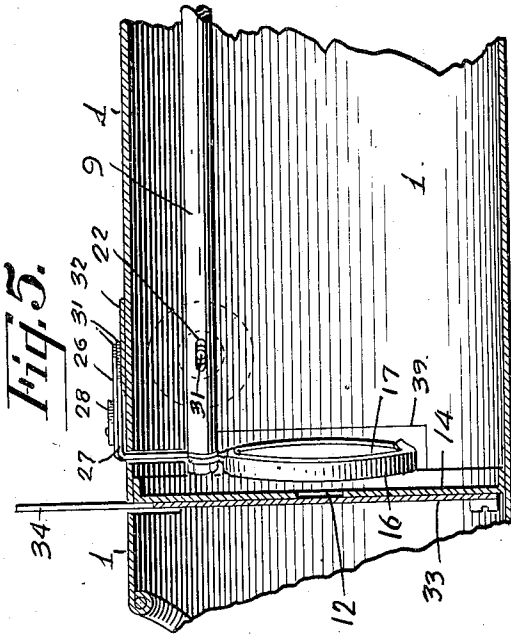

Fig. 5.

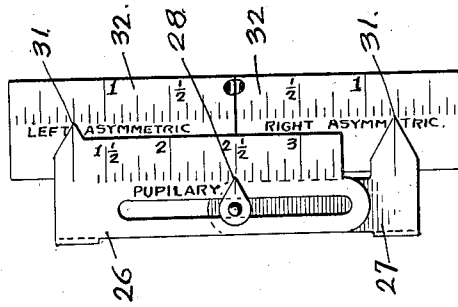

Fig. 6.

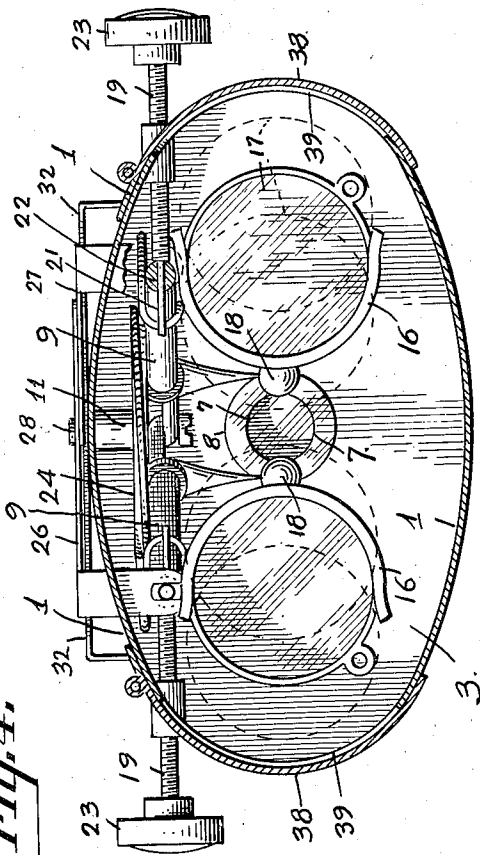

Fig. 4.

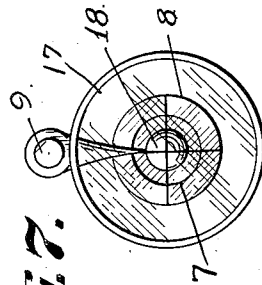

Fig. 7.

INVENTOR.
 BERT C. HERSCH.
 By *Arthur L. Slee*
 HIS ATTORNEY.

UNITED STATES PATENT OFFICE

2,022,202

PUPILLOMETER

Bert C. Hersch, San Jose, Calif.

Application January 8, 1935, Serial No. 827

10 Claims. (Cl. 33—200)

My invention relates to improvements in a pupillometer wherein a housing provided with a centrally disposed target in one closed end thereof has the other end formed to enclose the upper portion of the face and eyes of a patient and operates in conjunction with beads movable into alignment between the eyes of the patient and said target, and means for indicating the amount of said movement or relative position of said beads whereby the pupillary distance between the eyes and asymmetric conditions thereof may be determined.

The primary object of the present invention is to provide a new and improved pupillometer.

Another object is to provide a new and improved device of the character set forth which is simple and accurate in construction and operation.

A further object of the invention is to provide new and improved means for ascertaining and indicating the presence of any asymmetrical condition of the eyes of a patient by separately indicating the distance of either pupil from a median facial line.

I accomplish these and other objects by means of the device disclosed in the accompanying drawings forming a part of the present application, in which—

Fig. 1 is a horizontal, longitudinal sectional view of the housing of my improved device, the internal mechanism being shown suspended;

Fig. 2 is a longitudinal vertical section;

Fig. 3 is a front elevation of the front end of the device;

Fig. 4 is an enlarged transverse sectional view;

Fig. 5 is a broken longitudinal section representing a side view of Fig. 4;

Fig. 6 is a plan view of the scale arrangement; and

Fig. 7 is a partial diagrammatic view showing the manner in which the lens, bead and target may be aligned to the view of a patient or operator.

Referring to the drawings, the numeral 1 is used to designate a substantially long housing, preferably elliptical in cross section, having one end closed and the other end substantially open and formed arcuate as at 2, to receive the upper portion of the face and eyes of a patient.

A partition 3 is spaced a short distance from the closed end of the housing 1 to form a compartment 4 within which is centrally disposed a suitable lamp 6, the purpose of which will hereinafter be more fully set forth. Upon the inner side of the partition 3 I have provided a centrally

and vertically disposed target comprising a central aperture 7 covered by a circular glass 8 so that said glass 8 may be illuminated by the lamp 6, through said aperture 7.

A pair of longitudinally disposed divergent arms 9 are pivotally connected at one end and in the plane of the target 8, and to the housing 1 as at 11, the opposite or free ends of said arms extending toward the front end of the housing 1 and with the end of each arm adjacent and opposite one of a pair of horizontally disposed slots 12, aligned with the target 8, within a partition 14 arranged in spaced relation to the open end of the housing 1, said arms 9 being arranged above a line between said target 8 and slots 12, as disclosed in Figs. 2, 4, 5, and 7 of the drawings, the purpose of which will hereinafter more fully appear.

A suitable lens holder 16 is secured to each free end of each arm 9 to detachably engage and hold a suitable lens 17. A bead 18 is arranged upon each arm 9 intermediately the ends thereof and depending into alignment with the horizontal center of the slots 12 and target 8, said beads being located equidistant from said target and smaller in diameter than the diameter of the aperture 7 back of the target 8.

A laterally disposed threaded stem 19 is screwed, one on each side, through the housing 1, the interior end of each stem 19 being provided with a reduced portion 21 passing through a horizontally disposed slot 22 within each arm 9 whereby the free ends of said arms 9 may not only be held in proper horizontal elevation but also moved relatively to each other and/or to the housing 1 when said stems 19 are rotated by means of suitable knobs 23 on the exterior ends thereof. A suitable spring 24 engages both arms 9 and exerts a tension in a direction that will tend to move said arms away from each other and also to retain said arms 9 in engaging relation with the reduced portions 21 of the threaded stems 19, as disclosed in Fig. 1 of the drawings.

Also mounted upon the free end of one arm 9 is a calibrated extension 26 slidably engaging an extension 27, mounted upon the free end of the other arm 9, having a pointer 28 for indicating the proper calibration on the extension 26, both extensions 26 and 27 extending exteriorly of the housing 1, preferably on top thereof and adjacent the ends of the arms 9, to facilitate observation thereof. Both extensions 26 and 27 are provided with additional pointers 31 for indicating indicia on a double scale 32 arranged horizontally and transversely upon the

top of the housing 1 and adjacent the said extensions 26 and 27.

A suitable sector-shaped shutter 33 is pivotally mounted upon the partition 14 and so arranged that it may be moved upon its pivot to close either slot 12 and open the other, as disclosed in full and dotted lines in Fig. 3 of the drawings. The shutter 33 is provided with a handle 34 which extends exteriorly of the housing 1 directly above the slots 12 and always leans or inclines toward the closed slot, thereby always indicating which slot is closed or open.

Suitable doors 38 are hingedly mounted upon the opposite sides of the housing 1 to normally close, by gravity, or otherwise, suitable openings 39 arranged opposite the lens holders 16, whereby lenses 17 may be changed to suit the vision of the eyes being tested.

In operation the lamp 6 is illuminated by connection to a suitable source of electrical energy, not shown, to in turn illuminate the central aperture 7 of the target 8. As the interior of the housing 1 is darkened, the illuminated target and its respective bead 18 are the only objects visible to an observer peering through one of the slots 12, the other slot being closed by the shutter 33.

If the said bead 18 is not in registration with the illuminated aperture 7 of the target 8 the arm 9 to which said bead is attached is moved by the threaded stem 19, when its knob 23 is rotated in the proper direction, to bring said bead 18 into such registration, which movement will also bring the lens 17 into alignment with the line of vision between the eye being tested and said target. In other words, the bead 18 and lens 17 on either arm are always in proper alignment so that when the proper adjustment is made the bead 18, being of smaller diameter than the illuminated aperture 7 of the target 8 will form an illuminated annulus of substantially the same width throughout.

As the arm 9 is moved to produce such registration of the bead 18 with the target 8, the extension 26 or 27, as the case may be, is also moved so that its pointer 31 will indicate a calibration upon its respective side of the double scale 32 and thereby indicate the position of the eye being tested, relatively to a median line of the features, it being understood that the face of the patient has previously been centered within the arcuate open end 2 of the housing 1. By means of this arrangement any asymmetrical features of the eye being tested will be readily indicated upon the double scale 32, after the other eye has been tested.

One eye having been tested, the shutter 33 is moved by the arm 34 to close the slot 12 in front of the eye tested and open the opposite slot in front of the other eye. The other arm 9, with its aligned lens 17 and bead 18 is adjusted as above described to register the remaining bead 18 with the target 8, the scale extension 26 or 27, as the case may be, being similarly moved to indicate the relative position of the second lens to a median facial line by means of the pointer 31, whereby not only any asymmetrical features of the second eye may be indicated by a difference in the positions of the two pointers 31, but also the direct pupillary distance between the eyes will be indicated by the pointer 28 on the slidably connected scales 26 and 27, said scales being calibrated to indicate the exact pupillary distance between the eyes being tested.

As the arms 9 are being moved in either direction the tension of the spring 24 will always re-

tain said arms 9 in engaging relation with their respective threaded stems 19 and will also take up any lost motion. The extensions 26 and 27 being rigidly secured to the ends of the arms 9 will therefore correctly indicate the proper pupillary measurements between the eyes and any asymmetrical differences which may exist.

Having thus described my invention, I claim—

1. A pupillometer comprising a housing having an open end formed to fit over and enclose both eyes of a patient; a target mounted within the opposite end of said housing; a pair of arms pivotally connected together at one end in the plane of said target; a bead mounted upon each arm; and means for moving said arms independently of each other to bring the beads thereon into the lines of sight between the eyes and the target whereby the pupillary distance between the pupils of said eyes may be determined.

2. A pupillometer comprising a housing having an open end formed to fit over and enclose both eyes of a patient; a target mounted within the opposite end of said housing; a pair of arms pivotally connected together at one end in the plane of said target; a bead mounted upon each arm; means for moving said arms independently of each other to bring the beads thereon into the lines of sight between the eyes and the target; and means for indicating the relative positions of said arms whereby the pupillary distance and/or any asymmetry between said eyes may be determined.

3. A pupillometer comprising a housing having an open end formed to fit over and enclose both eyes of a patient; a target mounted within the opposite end of said housing; a pair of arms pivotally connected together at one end in the plane of said target; a bead mounted upon each arm; means for moving said arms independently of each other to bring the beads thereon into the lines of sight between the eyes and the target whereby the pupillary distance between the pupils of said eyes may be determined; and shutter means for concealing said target from the view of either eye whereby separate registration of each bead with an eye and said target may be accomplished.

4. A pupillometer comprising a housing having one end open and shaped to fit over and enclose both eyes of a patient; a target mounted within the other end of said housing; a pair of diverging arms pivotally connected at one end only and in the plane of said target; a bead mounted upon each arm, said beads being equidistant from the pivotal point of said arms; a lens mounted upon the opposite end of each arm and axially aligned with the bead thereon; and means for moving each arm independently of the other to bring the lenses and beads thereon into the lines of sight between the eyes at the open end of said housing and said target whereby the pupillary distance between said eyes may be determined.

5. A pupillometer comprising a housing open at one end and shaped to enclose the eyes of a patient and having the other end closed; a vertical target mounted within said closed end of said housing; a pair of arms pivotally connected at one end in the plane of said target; a bead mounted upon each arm and equidistant from said target; means for moving each arm independently of the other to bring the bead thereon into line of sight between one of said eyes and into registration with said target; and a separate means for each arm for indicating 75

the position of said arm and bead thereon relatively to a median line of the face of said patient whereby the relative asymmetrical position of the pupil of each eye may be separately determined.

6. A pupillometer comprising a housing open at one end and shaped to enclose the eyes of a patient and having the other end closed; a vertical target mounted within said closed end of said housing; a pair of arms pivotally connected at one end in the plane of said target; a bead mounted upon each arm and equidistant from said target; means for moving each arm independently of the other to bring the bead thereon into line of sight between one of said eyes and into registration with said target; a separate means for each arm for indicating the position of said arm and bead thereon relatively to a median line of the face of said patient whereby the relative asymmetrical position of the pupil of each eye may be separately determined; and means for indicating the positions of said arms relatively to each other whereby the pupillary distance between said eyes may be determined.

7. A pupillometer comprising a housing open at one end and shaped to enclose the eyes of a patient and having the other end closed; a vertical target mounted within said closed end of said housing; a pair of arms pivotally connected at one end in the plane of said target; a bead mounted upon each arm and equidistant from said target; means for moving each arm independently of the other to bring the bead thereon into line of sight between one of said eyes and into registration with said target; a separate means for each arm for indicating the position of said arm and bead thereon relatively to a median line of the face of said patient whereby the relative asymmetrical position of the pupil of each eye may be separately determined; and shutter means for concealing said target from the view of either eye whereby each eye may be separately tested.

8. A pupillometer comprising a housing closed at one end and having the other end open and formed to enclose both eyes of a patient; a centrally disposed vertical target mounted within the closed end of said housing; a partition mounted adjacent the open end of said housing and provided with a pair of horizontally disposed slots arranged opposite a pair of eyes enclosed by said open end; a shutter mounted upon said partition and arranged to cover either slot and uncover the other; a lever connected to said shutter and extending exteriorly of said housing and inclined towards the closed slot; a pair of diverging arms pivotally connected at one end in the plane of said target; a lens-holder mounted upon the opposite end of each arm to hold a lens opposite one of the slots in the partition; a bead mounted upon each arm and aligned with a lens in said holder and said target; means for moving each arm independently of the other to bring a lens and bead thereon into a line of sight of one of a pair of eyes enclosed by the open end of the housing and said target; and means for indicating the position of either arm relatively to a facial median line whereby the pupillary distance and the asymmetry of said eyes may be determined.

9. A pupillometer comprising a housing closed at one end and having the other end open and formed to engage the upper portion of the face and enclose the eyes of a patient; a centrally and

vertically disposed circular target mounted within the enclosed end of the housing; a partition mounted adjacent the open end of said housing and having a pair of centrally disposed horizontal slots therein; a shutter pivotally mounted upon said partition and shaped to cover one slot when the other slot is uncovered and provided with an exteriorly extending operating lever inclined toward the closed slot; a pair of arms pivotally connected at one end in the plane of the target, said arms diverging each toward one of the slots in the opposite end of said housing; a holder on each divergent end of each arm for detachably holding a lens in horizontal alignment with said slot centers; a bead mounted upon each arm and in horizontal alignment with a lens in said holder and the target, said beads being arranged equidistant from said target and between said target and lens; and means for moving said arms independently of each other to align the lenses and beads thereon with the target whereby said rods may be moved to indicate the pupillary distance between a pair of eyes enclosed by the open end of the housing and peering through the slots adjacent thereto.

10. A pupillometer comprising a housing closed at one end and having the other end open and shaped to enclose a pair of eyes to be tested; a centrally and vertically disposed circular target mounted within the enclosed end of the housing; a partition mounted adjacent the open end of the housing and provided with a pair of horizontally disposed slots opposite a pair of eyes enclosed by said open end; a shutter pivotally mounted upon said partition and shaped to cover either slot and uncover the other and provided with a handle extending exteriorly of said housing and inclined toward the closed slot; a pair of diverging arms pivotally connected at one end and to said housing and in the plane of said target and on a central line passing vertically therethrough, the free ends of said arms diverging toward a point above the slots; a lens-holder mounted upon the free end of each arm and depending over the adjacent slot; a bead mounted intermediately of each arm and aligned with the center of the target and the lens on its arm, said beads being equidistant from said target; a threaded stem screwed laterally through each side of said housing and engaging with its inner end the adjacent arm and provided with a knob upon its outer end to facilitate rotation thereof whereby said arms may be moved independently of each other to align its respective lens and bead with the target; a double scale mounted upon the exterior of said housing and extending in opposite directions from a median longitudinal line thereof; an extension mounted upon the free end of each arm and extending exteriorly of said housing and having a pointer to indicate the relative position of each arm on said double scale to said median longitudinal line of said housing whereby the asymmetrical positions of said arms may be indicated, said extensions being calibrated to indicate their relative positions to each other whereby the pupillary distance of eyes being tested may be indicated; and means for normally retaining said arms in engaging relation with the threaded stems and for preventing relative movement of said arms to each other excepting as produced by rotation of said threaded stems.

BERT C. HERSCH,