

[54] BRIDGE SADDLE FOR GUITARS

[75] Inventors: Charles A. Gressett, Jr., Brea; Charles H. Todd, III, La Habra; John F. Page, La Mirada, all of Calif.

[73] Assignee: Fender Musical Instruments Corporation, Fullerton, Calif.

[**] Term: 14 Years

[21] Appl. No.: 492,344

[22] Filed: May 6, 1983

[52] U.S. Cl. D17/21

[58] Field of Search D17/14, 15, 18-21; 84/298, 299, 209, 307, 314 N

[56] References Cited

U.S. PATENT DOCUMENTS

D. 268,272 3/1983 Fender D17/20
3,396,284 8/1968 Scherer 84/299 X

OTHER PUBLICATIONS

The Guitar Book, T. Wheeler, ©'74, Harper & Row, N.Y., pp. 136 & 137, bottom and top photos, respectively.

Primary Examiner—Jane E. Corrigan
Attorney, Agent, or Firm—Gausewitz, Carr, Rothenberg & Edwards

[57] CLAIM

The ornamental design for a bridge saddle for guitars, substantially as shown and described.

DESCRIPTION

FIG. 1 is a front, top and left side perspective view of a bridge saddle for guitars showing our new design; FIG. 2 is a top plan view; FIG. 3 is a bottom plan view; FIG. 4 is a left side elevational view; FIG. 5 is a right side elevational view; FIG. 6 is a rear elevational view; and FIG. 7 is a front elevational view.

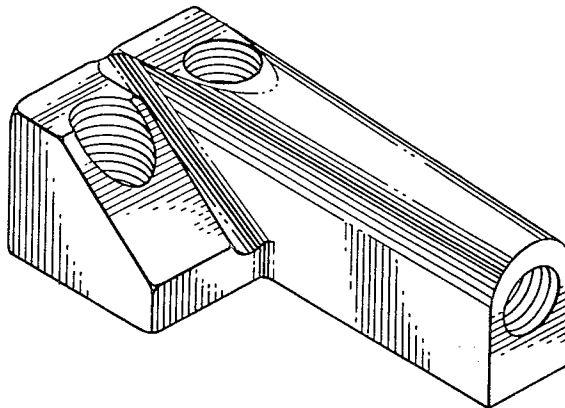

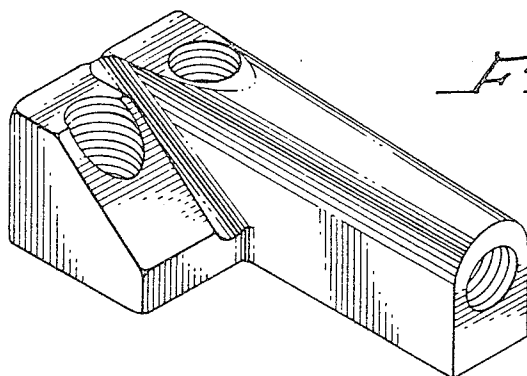

FIG. 1.

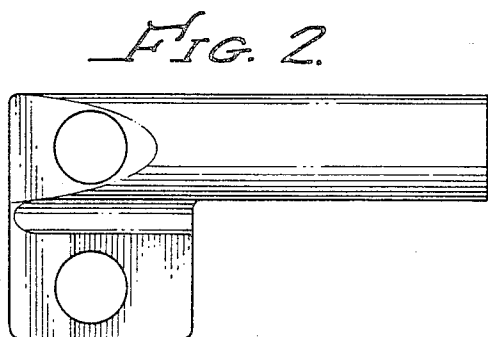

FIG. 2.

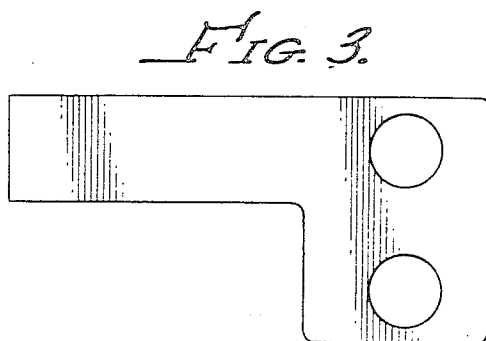

FIG. 3.

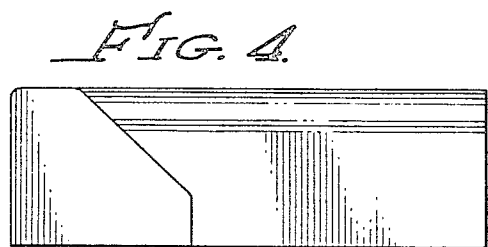

FIG. 4.

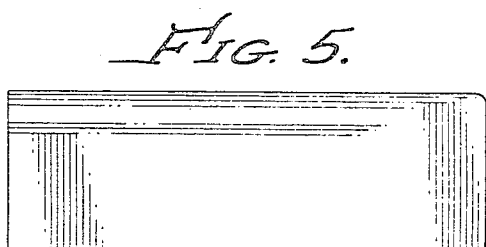

FIG. 5.

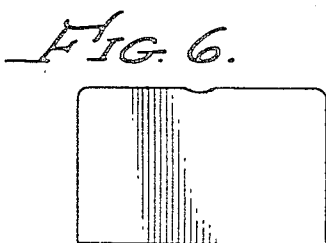

FIG. 6.

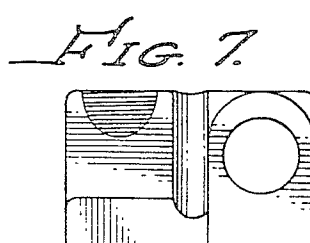

FIG. 7.