

(19) **DANMARK**

(10) **DK/EP 2759646 T3**



Patent- og
Varemærkestyrelsen

(12) **Oversættelse af
europæisk patentskrift**

-
- (51) Int.Cl.: **E 03 F 5/04 (2006.01)** **A 47 K 3/40 (2006.01)**
- (45) Oversættelsen bekendtgjort den: **2018-06-06**
- (80) Dato for Den Europæiske Patentmyndigheds bekendtgørelse om meddelelse af patentet: **2018-04-18**
- (86) Europæisk ansøgning nr.: **14152444.7**
- (86) Europæisk indleveringsdag: **2014-01-24**
- (87) Den europæiske ansøgnings publiceringsdag: **2014-07-30**
- (30) Prioritet: **2013-01-25 DE 102013001234**
- (84) Designerede stater: **AL AT BE BG CH CY CZ DE DK EE ES FI FR GB GR HR HU IE IS IT LI LT LU LV MC MK MT NL NO PL PT RO RS SE SI SK SM TR**
- (73) Patenthaver: **Dallmer GmbH & Co. KG, Wiebelsheidestrasse 25, 59757 Arnsberg, Tyskland**
- (72) Opfinder: **Dallmer, Johannes, Binnerfeld 27, 59757 Arnsberg, Tyskland**
- (74) Fuldmægtig i Danmark: **Plougmann Vingtoft A/S, Rued Langgaards Vej 8, 2300 København S, Danmark**
- (54) Benævnelse: **Indretning til et gulv afløb, anbragt i nærheden af en væg**
- (56) Fremdragne publikationer:
EP-A1- 2 184 415
DE-U1-202007 005 783
DE-U1-202011 051 047
US-A1- 2011 197 351
US-B1- 6 178 571

Description

The present invention involves a device pursuant to the generic term of claim 1.

5 These types of floor drains are usually installed in floor level showers, whereby frequently channel shaped drains are used. Previously it was required in the building of a floor level shower that a shower plate or shower board has gradients on multiple sides running toward the drain. It also has a design with sloping screed. For a drain in the middle of the shower area, a so-called central drain, usually four inclines are created. For a floor drain in the proximity of a wall, three of four sloping areas are formed.
10 For three sloping areas, the first is located at the side opposite the wall. The other two areas are formed in the longitudinal direction of the channel shaped drain, to the left and right of it. Individually there is also a short, fourth incline between the channel and the wall.

 One problem is that the formation of multiple incline areas in the floor screed or in a shower plate require a high manual or machine expenditure. In addition, the use of tiles on the various inclines is very
15 challenging.

 From DE 20 2011 051 047 U1 we know of a device of the type listed above. The device described in that has a vertical and a horizontal leg, both in a longitudinal direction parallel to the connection line of the wall and floor, which are more extensive than in the transverse direction or the vertical direction. In the horizontal leg there is a groove surrounding a drain opening. The bottom of the groove is tilted
20 toward the vertical leg. On the horizontal leg, a tile connector can be attached to the area surrounding the groove where tiles can be laid, which can be attached to the horizontal leg. The groove can be partially covered with a cover.

 From US 2011/0197351 we know of a shower tray. This has a quadratic or square shape. The floor of the shower tray has a floor opening and four segments sloping toward the drain opening.

25 The underlying problem of the current invention is the creation of a device of the type described above, which makes installation of a floor drain in the proximity of a wall easier.

 This is solved by a device such as described above with the characteristic features of claim 1. The sub-claims present the preferred design of the invention.

 The device of the invention is specially used between tiles installed on the wall and with a tile
30 with an incline. The invention offers the tradesmen and the shower plate manufacturers the option of only having to use a single-sided incline. This inclined surface can be located on the side of the device facing away from the wall. This reduces the effort in producing the floor screed and shower plate. In addition, there is not work for the production of the tiling in the area of the various incline transitions.

It may be designed the plurality of surfaces inclined with respect to the horizontal in the installed state of the device have inclinations that are different from one another or in that the device has a multislope contour on its upper side.

5 The device can have on average at least one significantly angled cross section. The device has a first leg which is vertical in the installed state and a second leg which is horizontal in the installed state, whereby at least one upper surface inclined in use on the second leg. In this way, the upper side of the second arm next to the tile forms the extension of the top side of the floor tile and the surface of the first leg forms the extension of the top side of the vertical wall tile.

10 The device is designed to be more elongated in the first direction than in a second and third direction, more vertical to the first direction, whereby the first direction in the installed state of the device is parallel to the connection line of floor and wall in the proximity of the drain and the third direction is vertical. Thus the opening for the water incursion in the floor extends in the first direction and is more elongated in the first direction than in the second direction, and particularly more than the third direction. The device can also be created as a narrow low angle component, which can be installed
15 in the connection area between the wall and floor of a room between the floor and/or wall covering and the drain. Despite its small dimensions under certain circumstances, the device that is the subject of the invention can effectively reduce the work or production expense for floor screed or shower plate.

It can be designed so that the inclined top surface is a free-form surface. The state of the art multiple different inclines formed in the floor screed or in a shower plate can be at least for the most
20 part be formed on the invention-related device.

There is the possibility that the uninclined upper surface has a constant height at its outer side in the installation position or its side facing a floor covering and has a U-shaped circumference. This U-shaped circumference surface can thus be a connection for the floor tiles around the device, whereby due to the consistent height, the integration of the tiles and the device is made much easier.

25 In the planned design, the device has a cover that partially covers the opening. It can be designed so that the cover forms a slotted drain opening with the first leg or, in the installed state, vertical leg and/or in that the cover has at least one drain opening. Through the formation of the drain opening between the first leg and the cover, the drain opening is reduced for the viewer to a narrow, barely visible slit, which is located in the connection area of the wall and floor.

30 It can be designed so that the device has a height between 10 mm and 250 mm in the third direction, in particular a height between 11 mm and 150 mm, preferably a height between 12 mm and 100 mm, for example a height between 12.5 mm and 50 mm.

There is a possibility that the opening is provided for the passage of water into a floor drain arranged below the device.

Additional characteristics and advantages of the present invention are clearly shown using the following description of the preferred design examples with reference to the attached images. In these

- 5 Fig. 1 shows a perspective view of an invention-related device in an installed state;
 Fig. 2 shows a cross section through an invention-related device in an installed state;
 Fig. 3 shows a perspective exploding view of an invention-related device;
 Fig. 4 shows a top view of an invention-related device;
 Fig. 5 shows a perspective bottom view of an invention-related device;
 Fig. 6 a cross section pursuant to arrows VI-VI in Fig. 4;
 10 Fig. 7 a cross section pursuant to arrows VII-VII in Fig. 4;
 Fig. 8 a cross section pursuant to arrows VIII-VIII in Fig. 4;
 Fig. 9 shows a perspective view of a connection piece of an invention-related device;
 Fig. 10 shows a front view of a connection piece of an invention-related device;
 Fig. 11 a perspective view of a second piece for the elongation of an invention-related device;
 15 Fig. 12 a front view of a second piece for the elongation of an invention-related device;
 Fig. 13 a perspective view of a cover of an invention-related device;
 Fig. 14 shows a front view of a cover of an invention-related device;
 Fig. 15 shows a perspective bottom view of a cover of an invention-related device.

20 In the figures, the same or functionally equivalent parts are shown with the same reference numbers. In addition, a Cartesian coordinate system is used to simplify orientation.

Figures 1 and 2 show an invention-related device 1 in an installed state. The device 1 is installed in the connection area between a floor 2 and a wall 3 of a wet room. The device 1 runs parallel to the connection line of the floor 2 and the wall 3 in a first direction which is labeled X in figure 1.
 25

The device 1 has at last a partially angled cross section. Thus, in its installed state it has first vertical leg 4 as well as a second horizontal leg 5 in the installed state. Fig. 2 shows that on the first leg 4 in the installed state is lying on the wall tiles 6 from above and that on the second leg 5 lies in the installed state on the floor tiles 7 from the right in fig. 2.

30 Fig. 2 also shows that the floor tiles 7 have an incline in the Y direction toward the wall. This incline can continue on the surface of the second leg 5, so that the water falling in the wet room can flow to the indicated slit shaped opening 21 in figure 1. In particular, the tile side edge of the upper side of the second leg 5 forms the extension of the top side of the floor tiles 7. Accordingly, the surface of the first leg 4 forms the extension of the top side of the vertical wall tiles 6.

In figure 3 we can see a design of the device in the invention in which in addition to a first L-shaped part 9, there are two L-shaped second parts 10, 11 which can extend the first part 9. The connection of the parts 9, 10 and 11 is made using connection piece 12, which can be inserted into swallowtail shaped inserts 13 on the bottom side of the second leg 5 of parts 9, 10, 11. Figures 10 and 12 show that the cross section of a connection piece 12 is consistent with the cross section of the swallowtail shaped insert 13.

The connection pieces 12 have an adhered or injected web on their bottom sides. Alternatively, the bottom side of the connection pieces 12 may also have a mineral or polymer layer to form an adhesion bridge for the tile adhesive.

In a central area of the top side of the second, horizontal leg 5 of the first part 9 of the device 1, there is an opening 8. It runs in the installation direction in the X direction and through the second leg 5 to the bottom in the Z direction (see Fig. 4 and Fig. 8). Waste water can enter the drain installed underneath the device 1 through the opening 8.

The installation position of the upper side of the second, horizontal, leg 5 of the first part 9 of the device 1 has various sections or upper surfaces 14, 15, 16 and 20. An upper U-shaped surface 14 extends in the installation direction horizontal or is not inclined toward the horizontal (see Fig. 4 and Fig. 6 to Fig. 8). The upper surface 14 runs along the front edges and along the anterior edge of the second leg 5 and is particularly made up of about 5 mm wide strips.

Two upper surfaces 15 of the second, horizontal, leg 5 of the first part 9 extend as narrower or 5 mm wide strips bordering the vertical leg from the front sections of the upper U-shaped surface 14 to the opening 8 (see Fig. 4 and Fig. 7 and Fig. 8). The two upper surfaces 15 are inclined in the X direction toward the opening 8, so that the water can run on the upper surfaces 15 from the edges of the first part 9 or of the device 1 down to the opening 8.

Two upper surfaces 16 of the second, horizontal leg 5 of the first part 9 are arranged in the X direction as narrow, edge noses on the front ends of opening 8 in the X direction (see Fig. 3 and Fig. 5). The surfaces 16 extend in the area of the opening 8 from the U shaped upper surface 14 in the Y direction to the inside (see Fig. 3, Fig. 5 and Fig. 8).

These surfaces 16 have a recess 17 which can grab onto a nose piece 18 of a cover 19 (see also Fig. 8 and Fig. 13 to Fig. 15). When the nose piece 18 is inserted into the recess 17, a flush positioning of the cover 19 is achieved in the first part 9. The cover 19, with the first leg 4 or the leg vertical in the installed state, forms a slit shaped drain opening 21 (see Fig. 1 and Fig. 4), which opens into the opening 8, through which the water can run down the drain under the device (not shown).

The surfaces 16 and the cover 19 are formed so that the top of the cover 19 in the installation position is inclined in the Y direction toward the slit shaped drain opening 21, so that the water can run via the cover 19 into the slit shaped drain opening 21 and through it into the opening 8 (see Fig. 8).

5 Two upper surfaces 20 of the second, horizontal leg 5 of the first part 9 extend between the upper surfaces 14, 15 to the slit shaped drain opening 21 or to the cover 19 (see Fig. 4 and Fig. 7). The upper surfaces 20 are formed as free-form surfaces and inclined in the X and Y directions to the slit shaped drain opening 21.

10 The device 1 or the first part 9 of the device 1 preferably has a length in the X direction of 100 mm up to 2500 mm.

The device 1 or the first part 9 of the device 1 preferably has a width in the Y direction of 10 mm up to 250 mm.

The device 1 or the first part 9 of the device 1 preferably has a height in the Z direction of 10 mm to 250 mm.

15 The device 1 or the first part 9 of the device 1 has a larger extension in its longitudinal direction, which is the X directions in the figures, as the cross direction in the Y direction or the vertical Z directions.

20 The L-shaped parts 9, 10, 11 may be made of metal and/or plastic. The connection piece 12 and/or the cover 19 can also be made of metal and/or plastic. In particular, one or all of the components may be made of chrome plated bronze, in order to achieve an aesthetically pleasing look. There is also an option to make some or all of the components of sustainable raw materials.

25 There is a possibility that instead of a wall side drain opening 21 between the cover 19 and the first arm 4 there can be a drain opening in the cover 19. This at least one drain opening can also be slit shaped and extend in the X direction and/or the Y direction. For example, this could be at least one drain opening in the center or bordering the floor tile side of the cover. Instead of at least one slit-shaped drain opening there can also be multiple other drain openings, such as circular or square in the cover.

Patentkrav

1. Indretning (1) til et gulvafløb, anbragt i nærheden af en væg, omfattende:

- 5 - en åbning (8) til gennemgang for vand i gulvafløbet, hvorved indretningen (1) i en første retning (X) er mere udvidet end i en anden og en tredje retning (Y, Z), som er vinkelrette på den første retning (X) og indbyrdes, hvorved den første retning (X) i indbygget tilstand for indretningen (1) er parallel med forbindelseslinjen mellem gulv og væg i området ved afløbet, og den tredje retning (Z) svarer til lodret retning, 10 hvorved åbningen (8) strækker sig i den første retning (X) og i den første retning (X) er mere udvidet end i den anden retning (Y),
- i det mindste en skråtstillet flade (15, 20), der i den indbyggede tilstand for indretningen (1) er en øvre flade og i forhold til vandret er skråtstillet, således at vandet via den mindst ene skråtstillede, øvre 15 flade (15, 20) kan strømme til åbningen (8),
- et første sidestykke (4), som i det væsentlige er lodret i den installerede tilstand,
- et andet sidestykke (5), der i det væsentlige er vandret i den installerede tilstand, hvorved den mindst ene skråtstillede flade (15, 20), som i anvendelsespositionen er den øverste flade, er arrangeret på 20 det andet sidestykke (5), og hvorved åbningen (8) er tilvejebragt i det andet sidestykke (5),
- et dæksel (19), som delvist dækker åbningen (8),

kendetegnet ved, at indretningen (1) på det andet sidestykke (5) omfatter en 25 anden øvre flade (14), som ikke har nogen hældning og strækker sig langs kanterne på endefladerne og langs frontkanten på det andet sidestykke (5), ved, at den skråtstillede, øvre flade (15, 20) omfatter to øvre flader (15), som hælder i den første retning (X) mod åbningen (8) og strækker sig grænsende op til det første sidestykke (4) fra kanterne på den ikke-hældende, øvre flade (14) hen 30 imod åbningen (8), og ved, at den skråtstillede, øvre flade (15, 20) yderligere omfatter to yderligere øvre flader (20), der hver for sig strækker sig mellem den ikke-hældende øvre flade (14) og fladerne (15), som grænser op til det første sidestykke (4) hen imod dækslet (19), hvorved de to øvre flader (20), der hver

for sig strækker sig mellem den ikke-hældende øvre flade (14) og fladerne (15), som grænser op til det første sidestykke (4), i anvendelsespositionen har en hældning i forhold til vandret i den første og den anden (X, Y) retning.

- 5 **2.** Indretning (1) ifølge krav 1, **kendetegnet ved, at** de adskillige, i indbygget tilstand for indretningen (1) i forhold til vandret hældende, flader (15, 20) har indbyrdes forskellig hældning, henholdsvis at indretningen (1) på sin overside omfatter en fler-hældningskontur.
- 10 **3.** Indretning (1) ifølge et hvilket som helst af kravene 1 eller 2, **kendetegnet ved, at** indretningen (1) i det mindste afsnitvist omfatter et i det væsentlige vinkelformet tværsnit.
- 4.** Indretning (1) ifølge et hvilket som helst af kravene 1 til 3, **kendetegnet ved,**
15 **at** de to øvre flader (20), der hver for sig strækker sig mellem den ikke-hældende øvre flade (14) og fladerne (15), som grænser op til det første sidestykke (4), er udformet som friformsflader.
- 5.** Indretning (1) ifølge et hvilket som helst af kravene 1 til 4, **kendetegnet ved,**
20 **at** den ikke-hældende øvre flade (14) på sin i indbygningsposition ydre, henholdsvis mod en gulvbelægning vendende side har konstant højde og har U-formet omkreds.
- 6.** Indretning (1) ifølge et hvilket som helst af kravene 1 til 5, **kendetegnet ved,**
25 **at** afdækningen (19) med det første sidestykke (4) henholdsvis med det i den indbyggede tilstand lodrette sidestykke danner en slidsformet udløbsåbning (21), og/eller at afdækningen (19) i det mindste omfatter en udløbsåbning.
- 7.** Indretning (1) ifølge et hvilket som helst af kravene 1 til 6, **kendetegnet ved,**
30 **at** indretningen (1) i den tredje retning (Z) har en højde mellem 10 mm og 250

mm, navnlig en højde mellem 11 mm og 150 mm, fortrinsvis en højde mellem 12 mm og 100 mm, for eksempel en højde mellem 12,5 mm og 50 mm.

8. Indretning (1) ifølge et hvilket som helst af kravene 1 til 7, **kendetegnet ved,**
5 **at** åbningen (8) for gennemgang af vand er tilvejebragt i et neden under
indretningen (1) anbragt gulv afløb.

Fig. 1

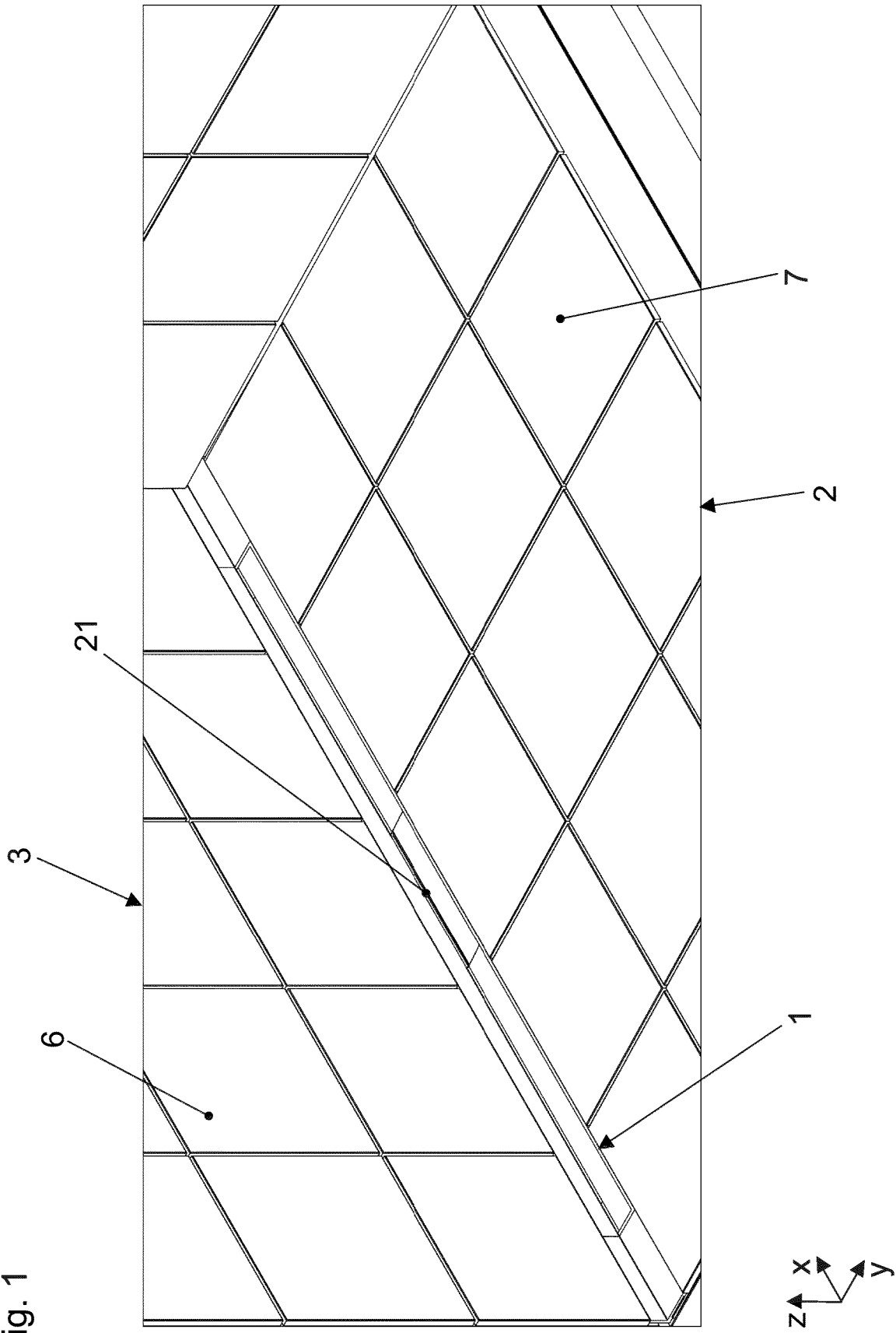
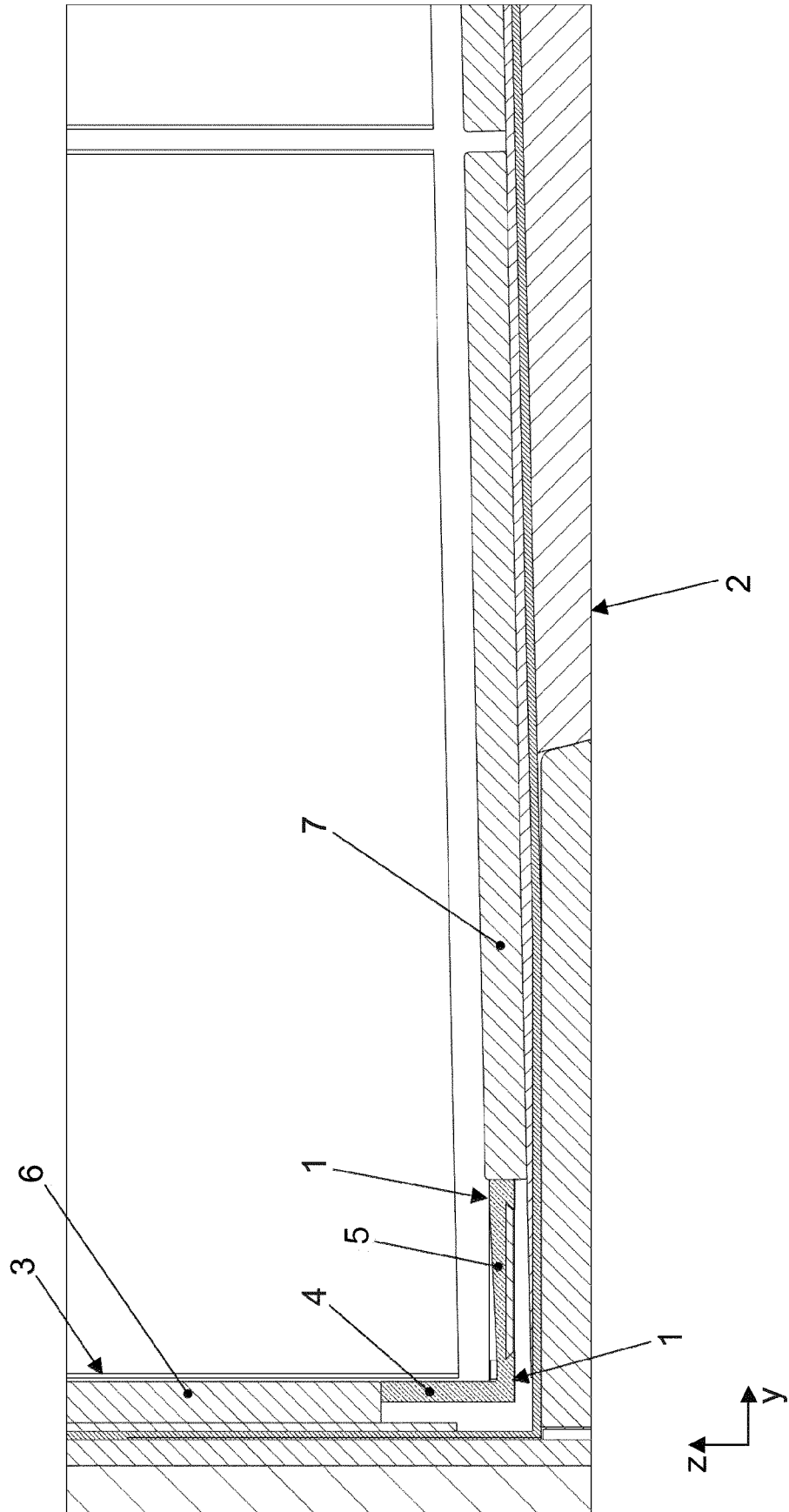

Fig. 2



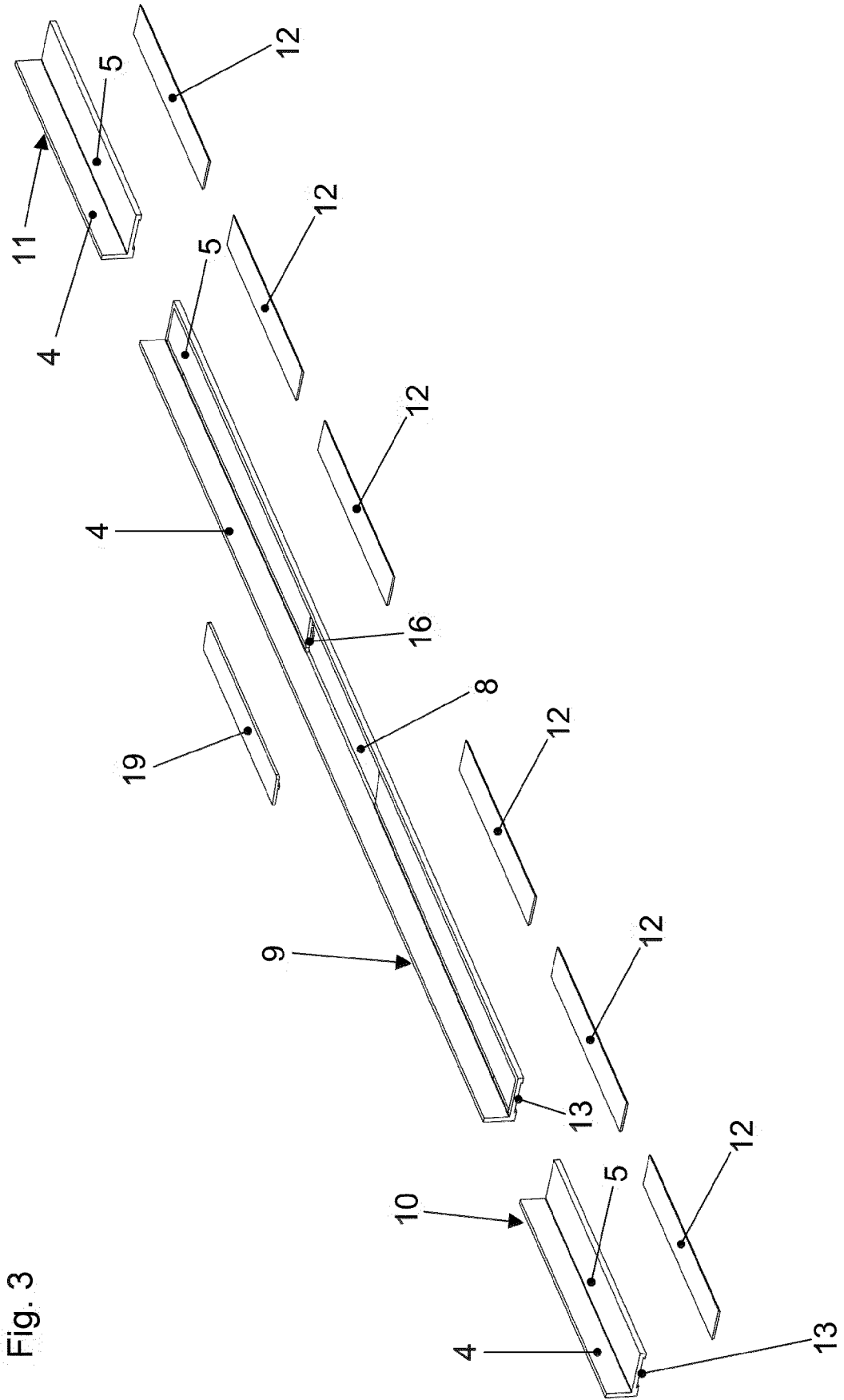

Fig. 3

Fig. 4

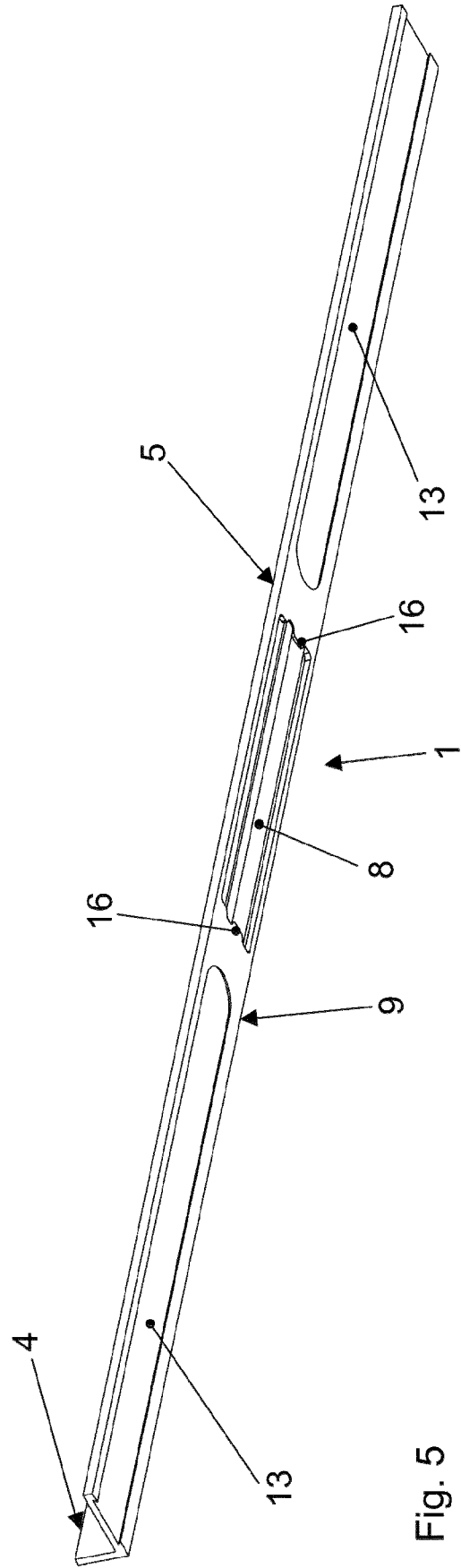
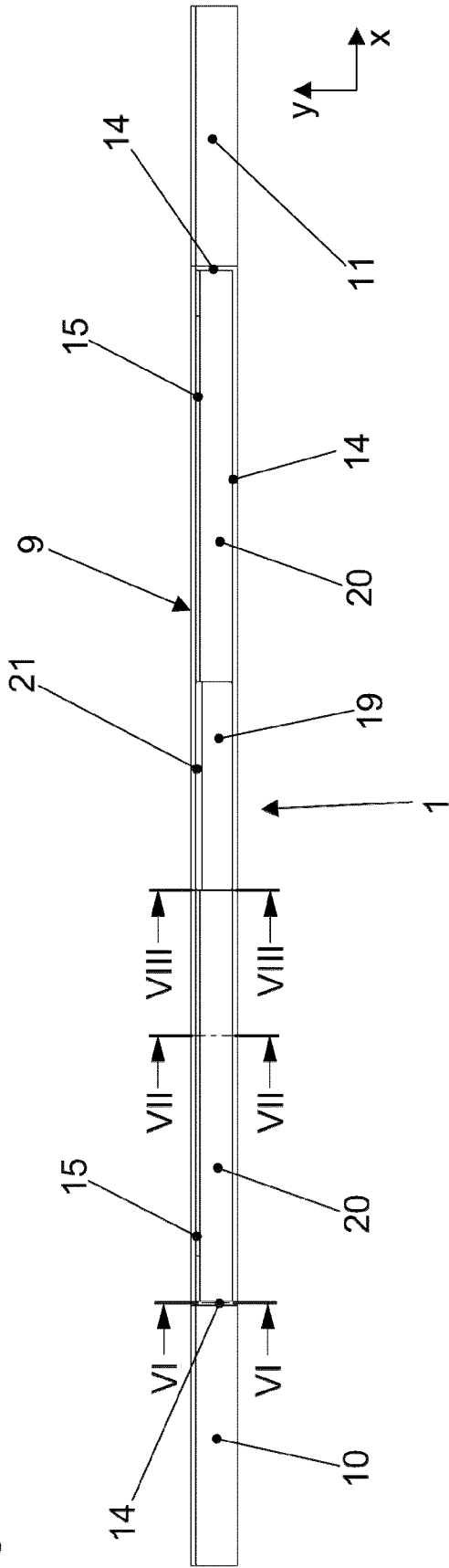

Fig. 5

Fig. 6

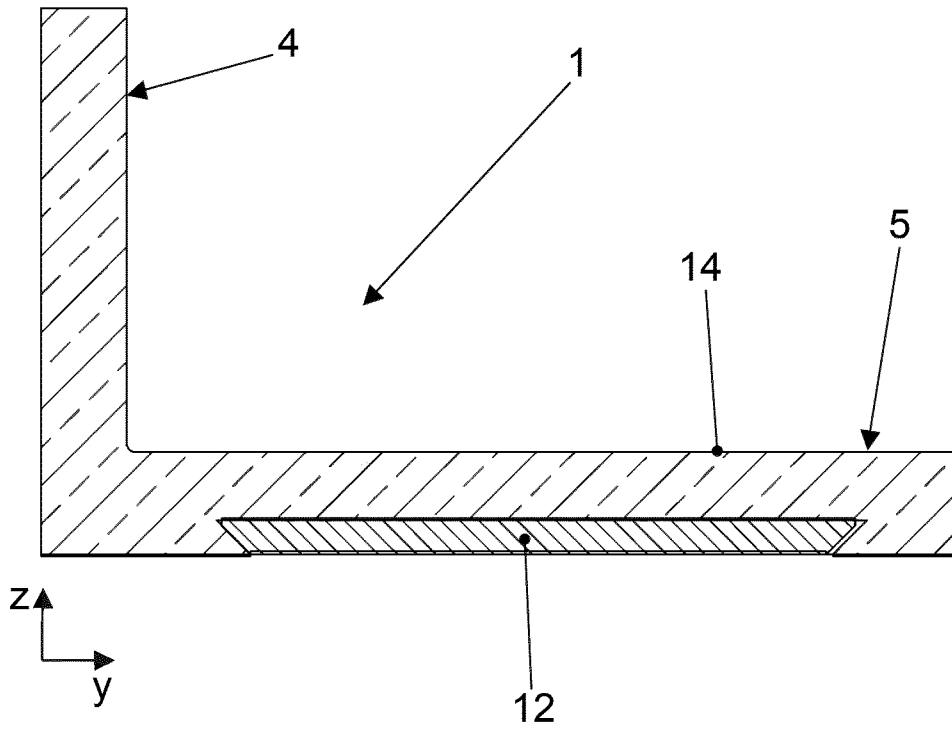

Fig. 7

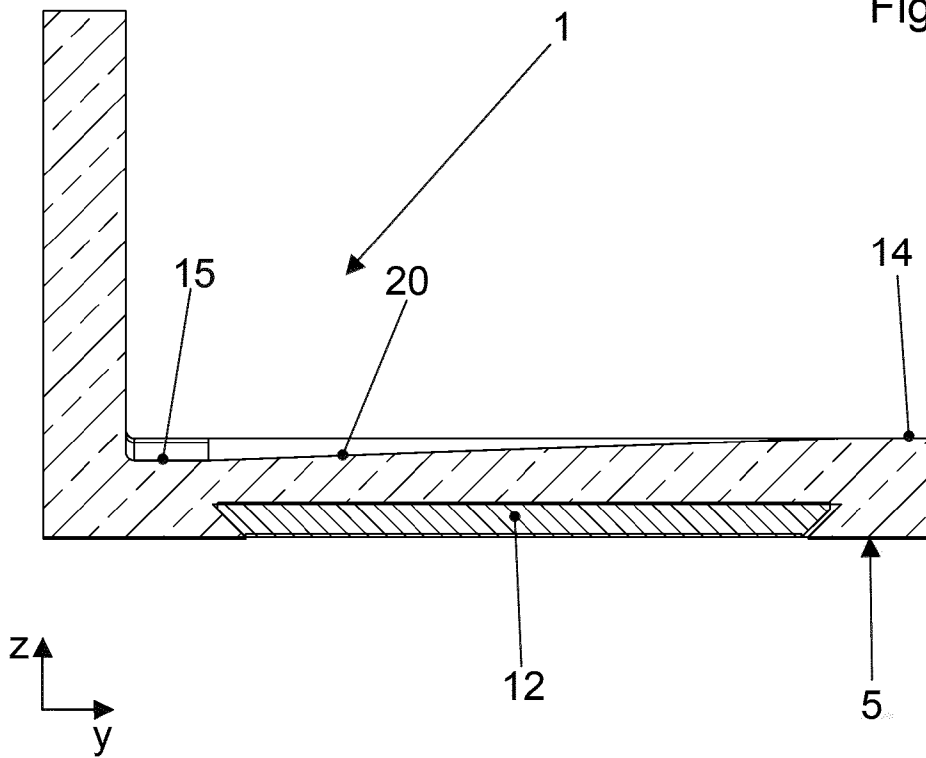

Fig. 8

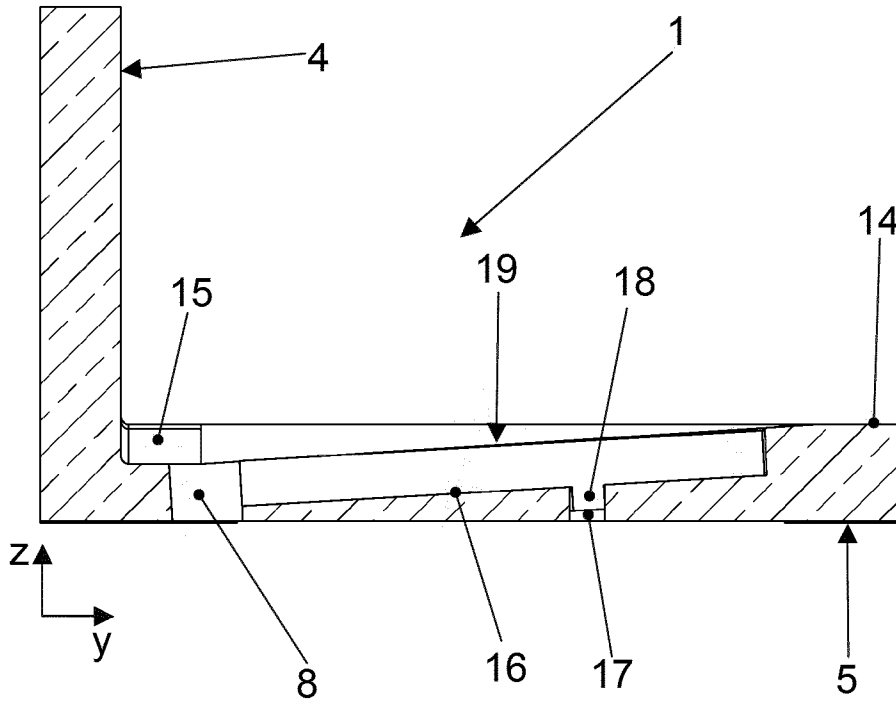

Fig. 9

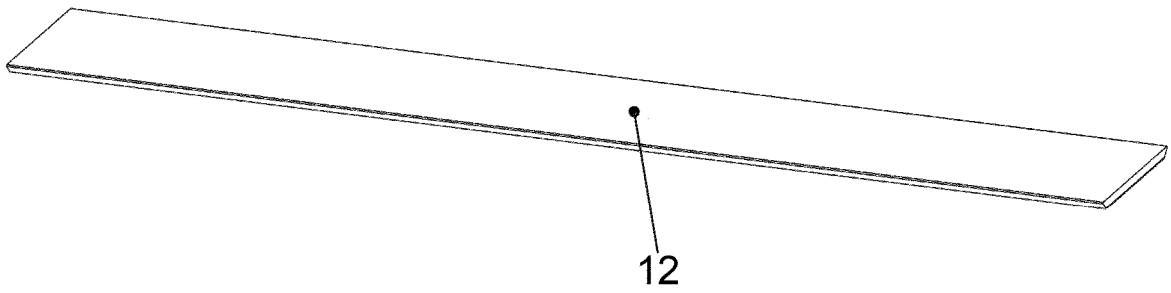

Fig. 10

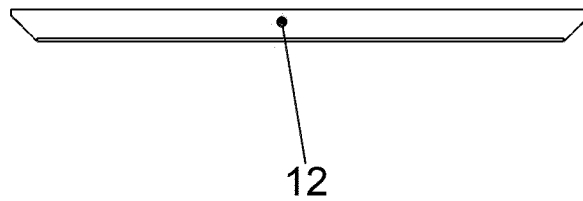

Fig. 11

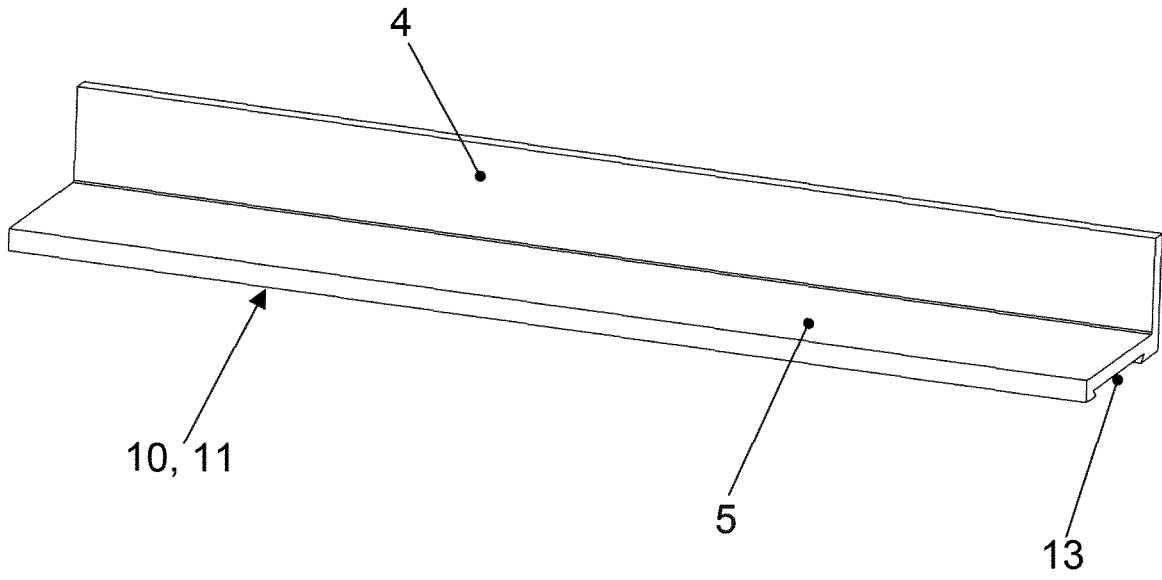

Fig. 12

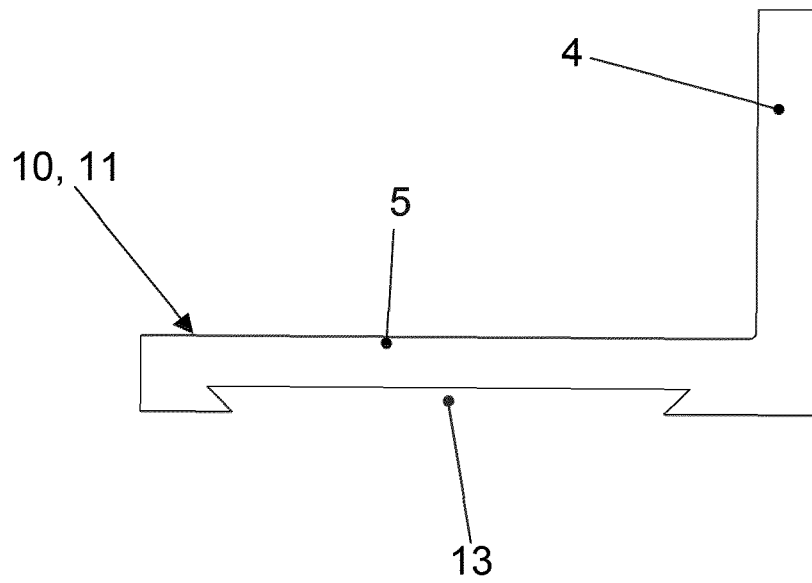

Fig. 13

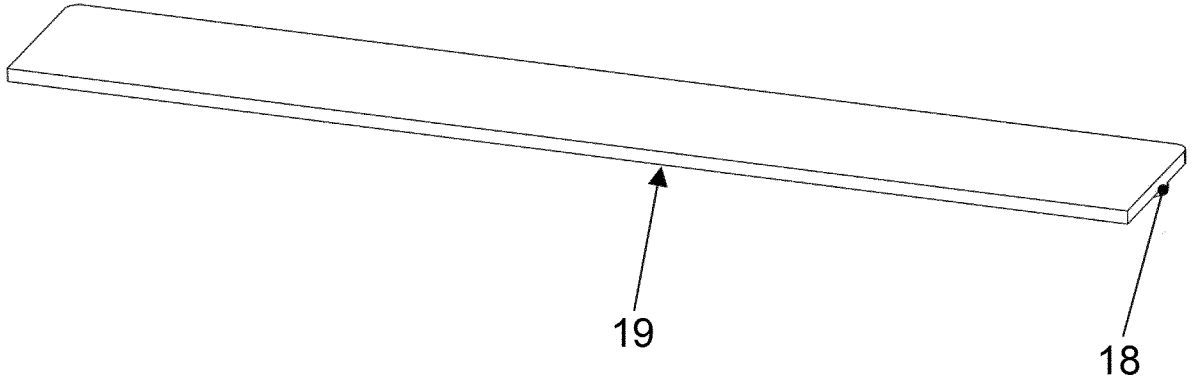

Fig. 14

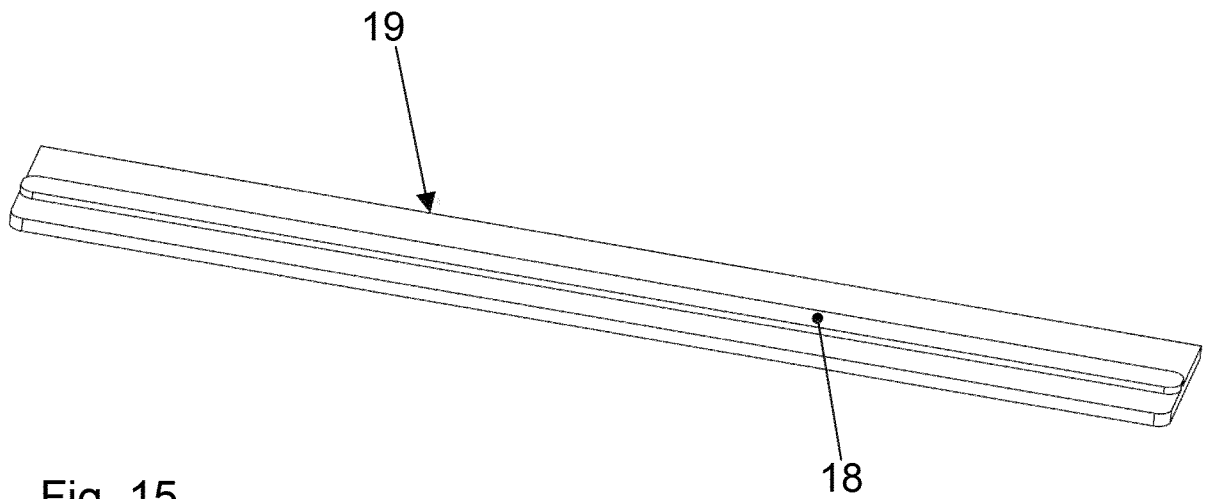
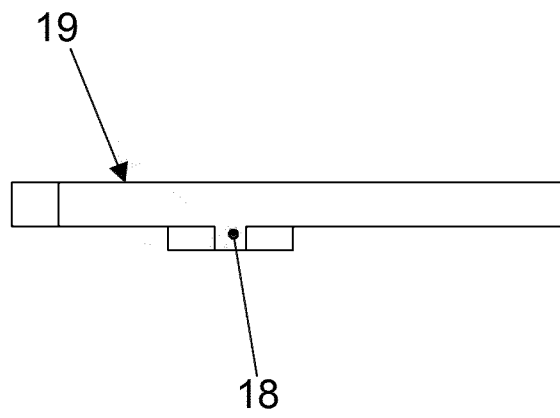

Fig. 15