



(12) **EUROPEAN PATENT APPLICATION**

(43) Date of publication:
19.11.2008 Bulletin 2008/47

(51) Int Cl.:
B65D 85/804^(2006.01)

(21) Application number: **08156048.4**

(22) Date of filing: **12.05.2008**

(84) Designated Contracting States:
AT BE BG CH CY CZ DE DK EE ES FI FR GB GR HR HU IE IS IT LI LT LU LV MC MT NL NO PL PT RO SE SI SK TR
 Designated Extension States:
AL BA MK RS

(72) Inventors:
 • **Macchiavelli, Davide**
40068 San Lazzaro Di Savena (IT)
 • **Rondelli, Raffaele**
Funo Di Argelato 40050 (IT)

(30) Priority: **10.05.2007 IT BO20070345**

(74) Representative: **Jorio, Paolo et al**
STUDIO TORTA
Via Viotti 9
10121 Torino (IT)

(71) Applicant: **Arnoplast S.r.l.**
San Lazzaro di Savena (IT)

(54) **Capsule for infusion products**

(57) The capsule (1) comprises a bowl (2) made of plastic material having a side wall (3) and a perforated base wall (4). The main characteristic of the present invention consists of the fact that it comprises a disk (6) which is arranged in correspondence with the base wall (4) and is suitable so that its peripheral edge comes into

contact with an area of the side wall (3) so that during percolation due to the pressure of the hot water entering the bowl (2) and/or the temperature of the water and/or the pressure exerted on the bowl (2) by the means defining a percolation chamber, after a given time at least one passage is defined between the side wall (3) and the disk (6).

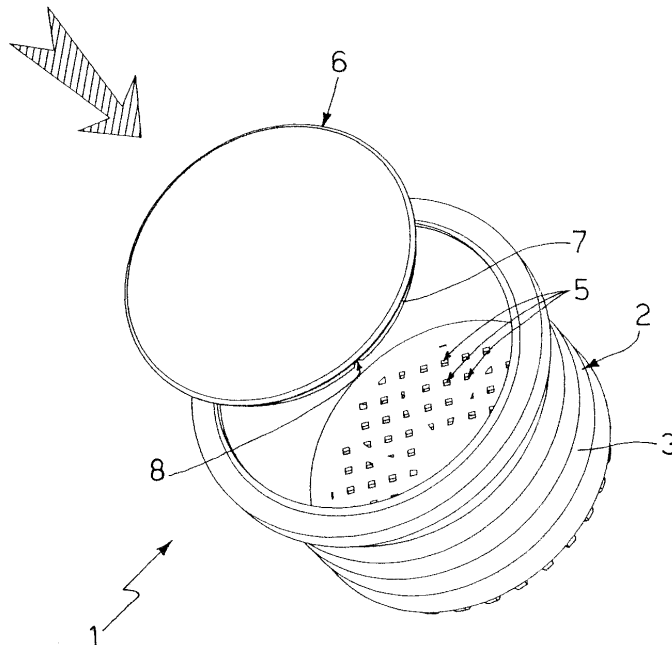

Fig.1

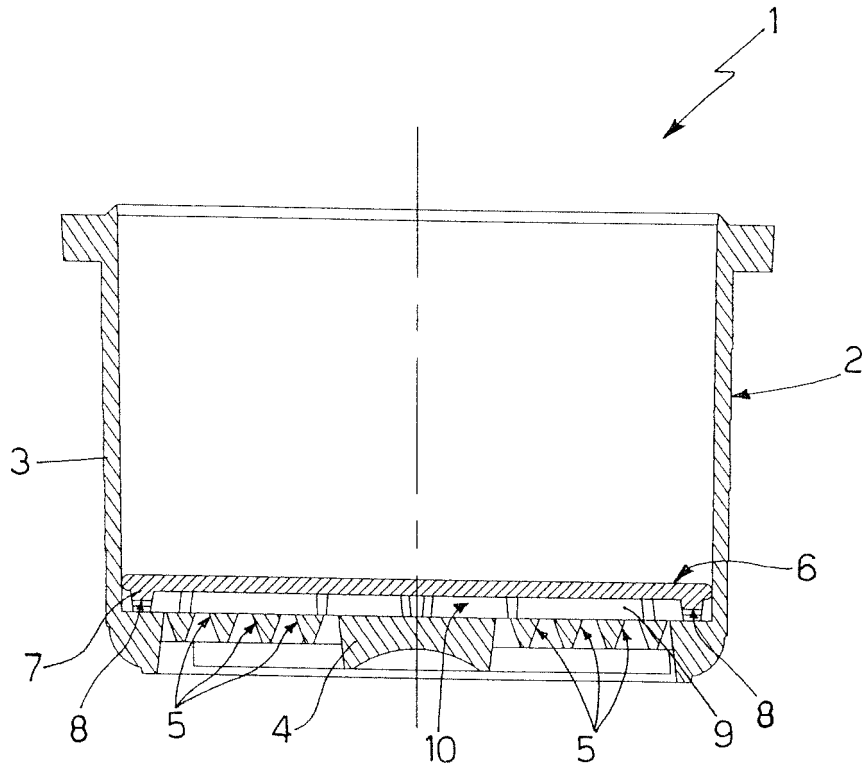

Fig.2

Description

[0001] The present invention relates to a capsule for the containment of infusion products in granular, leaf or powder form such as for example coffee, barley, milk powder, tea, chamomile, etc.

[0002] As is known, the capsules for infusion products currently available on the market comprise a bowl made of rigid plastic material closed at the top by a perforated cover made of rigid plastic material or by a perforated film. Inside the bowl there is a filter arranged so that it comes into contact with the base wall of the bowl and the infusion product; the base wall of the bowl is also perforated. In use, the capsule is inserted in a percolation chamber of a beverage extraction machine, where hot water is delivered under pressure onto the cover and reaches the product contained in the capsule. The water mixes with the product and flows out of the capsule through the holes in the base wall of the bowl; the filter is suitable to trap the powder product.

[0003] The capsules described above have a number of drawbacks.

[0004] In particular, the hot water that enters the capsule meets the product, absorbs the aromas and immediately flows out of the capsule. In this short time the water cannot absorb all of the product's aromas and frequently does not even touch some parts of the product. Consequently more product must be placed in the bowl to obtain a good beverage. To overcome this problem, some companies define a longer path for the hot water inside the bowl but this increases the cost of the bowl in that it must be provided with longer water channelling. Another drawback in the capsules described above is associated with the fact that the powder product escapes from the capsule through its base wall even before it is used and some infusion product can be found in the package containing the capsules.

[0005] The purpose of the present invention is to produce a capsule for infusion products that overcomes the drawbacks described above.

[0006] According to the present invention a capsule for infusion products is produced of the type comprising a bowl made of plastic material provided with a side wall and a perforated base wall, characterized in that it comprises a disk that is arranged in correspondence with said base wall to define a chamber and is suitable so that its peripheral edge comes into contact with an area of said side wall so that during percolation due to the pressure of the hot water entering said bowl and/or the temperature of the water and/or the pressure exerted on said bowl by the means defining a percolation chamber, after a given time at least one passage is defined between said side wall and said disk towards said chamber and from this towards the outside through holes obtained in said base wall.

[0007] The present invention will now be described with reference to the attached drawings, illustrating several embodiments thereof, in which:

figure 1 is a perspective view of a first embodiment of a capsule according to the present invention; figure 2 is a cross-sectional view of the capsule of figure 1;

figures 3 and 4 are respectively a perspective view and a cross-sectional view of an element of the capsule of figure 1;

figure 5 is a cross-sectional view of a second embodiment of a capsule according to the present invention;

figure 6 is a cross-sectional view of a third embodiment of a capsule according to the present invention; figure 7 is a cross-sectional view of a fourth embodiment of a capsule according to the present invention; and

figures 8 and 9 are respectively a perspective view and a plan view of an element of the capsule of figure 7.

[0008] With reference to figures 1 and 2, number 1 indicates, as a whole, a capsule for infusion products comprising a truncated cone-shaped bowl 2 defined by a side wall 3 and by a base wall 4 provided with a plurality of holes 5. The bowl 1 is made of rigid plastic material suitable for use with food. Inside the bowl 2 there is a disk 6 made of plastic material the diameter of which is equal to the inside diameter of an area of the side wall 3 next to the base wall 4.

[0009] With reference to figures 3 and 4, the face of the disk 6 facing towards the base wall 4 is provided with an annular crown 7 along which notches 8 are arranged in a radial direction. Tabs 9 also originate radially from the crown 7 towards the centre of the disk. The crown 7 and the tabs 9 preferably rest on the base wall 4 of the bowl 2 so as to define between the crown 7 and the base wall 4 a chamber 10 as illustrated in figure 2. The bowl 4 is provided with a perforated cover which is not illustrated made either of rigid plastic material or plastic film.

[0010] In actual use, the capsule 1 is inserted in a percolation chamber (of a known type and not illustrated) of a beverage extraction machine (not illustrated). Said percolation chamber is defined by an upper hot water supply element that rests sealingly against the cover of the capsule 1 and by a lower beverage extraction element on which the base wall 4 of the bowl 2 rests sealingly. Hot water is delivered under pressure through the cover which is not illustrated into the bowl 2. The water comes into contact with the product contained in the bowl and for the time being does not flow out of the latter due to the seal defined between the peripheral edge of the disk 6 and the side wall 3. Due to the pressure of the hot water and/or the temperature of the water and/or the pressure exerted on the bowl 2 by the elements of the percolation chamber, the side wall 3 is deformed exactly in correspondence with the area in which it comes into contact with the disk 6. Said deformation allows the beverage to flow between the disk 6 and the side wall 3; said beverage flows directly and through the notches 8 into the chamber

10 and from here towards a container beneath which is not illustrated.

[0011] Figure 5 illustrates a second embodiment of the capsule 1 which differs from that illustrated in figures 1 and 2 in that the disk 6 rests on projecting parts 11 defined between the base wall 4 and the side wall 3 of the bowl 2.

[0012] Figure 6 illustrates a third embodiment of the capsule 1 which differs from that illustrated in figures 1 and 2 in that the disk 6 rests on a projecting part 12 which extends upwards from the base wall 4 of the bowl 2.

[0013] Figure 7 illustrates a further embodiment of the capsule 1 which differs from that illustrated in figures 1 and 2 in that the disk 6 is provided with a hole in the centre 13 engaged by a cone-shaped projecting part 14 which extends upwards from the base wall 4 of the bowl 2.

[0014] In the embodiments illustrated in figures 5, 6 and 7 the disk 6 may not be provided with the crown 7 and the tabs 9. In said embodiments the functioning of the percolation chamber is similar to that described with reference to figure 1. In the embodiment illustrated in figures 7, 8 and 9 the disk 6 is provided with a break-off line 15 along a radius of said disk 6 so that again due to the pressure of the hot water and/or the temperature of the water and/or the pressure exerted on the bowl 2 by the elements of the percolation chamber the disk 6 ruptures along said break-off line 15 and the beverage flows towards the chamber 10 which is defined between the disk 6 and the base wall 4 of the bowl 2.

[0015] The advantages of the present invention are apparent from the above description.

[0016] In particular, with the capsule 1 the beverage flows out after a given period which is conducive to increased and more effective absorption of the aromas. The beverage remains in the bowl 2 above the disk 6 and only after passing, due to the pressure of the hot water and/or the temperature of the water and/or the pressure exerted on the bowl 2 by the elements of the percolation chamber, between the disk 6 and the base wall 4 of the bowl 2, the beverage flows out of the bowl through the holes 5. It is apparent that with the capsule 1 the beverage that is obtained is of better quality and requires the use of a smaller amount of infusion product. Moreover the disk 6 acts as a seal between the infusion product and the holes 5 so that said product does not escape from the bowl 2 prior to use.

[0017] Lastly, it is clear that modifications and variations may be made to the capsule 1 described and illustrated herein without departing from the scope of the present invention, as set forth in the appended claims.

[0018] For example the bowl 2 could have an essentially cylindrical or polygonal shape; in the latter case the development of the perimeter of the disk 6 would be essentially similar to the development of the inside of the bowl 2. The crown 7 and the tabs 9 constitute feet via which the disk 6 rests against the wall 4. It is apparent that the disk 6 could be provided with feet of a different shape and development from those described with reference to the attached drawings.

Claims

1. Capsule for infusion products of the type comprising a bowl (2) made of plastic material having a side wall (3) and a perforated base wall (4), **characterized in that** it comprises a disk (6) arranged in correspondence with said base wall (4) to define a chamber (10) and suitable so that its peripheral edge comes into contact with an area of said side wall (3) so that during percolation due to the pressure of the hot water entering said bowl (2) and/or the temperature of the water and/or the pressure exerted on said bowl (2) by the means defining a percolation chamber, after a given time at least one passage is defined between said side wall (3) and said disk (6) towards said chamber (10) and from this towards the outside through holes (5) obtained in said base wall (4).
2. Capsule, according to claim 1, **characterized in that** the development of the perimeter of said disk (6) is essentially similar to the development of the inside face of said side wall (3).
3. Capsule, according to claim 2, **characterized in that** said disk (6) has a diameter that is essentially equal to the inside diameter of an area of said side wall (3) next to said base wall (4).
4. Capsule, according to claim 2 and/or 3, **characterized in that** the face of said disk (6) facing towards said base wall (4) is provided with a plurality of feet (7 and/or 9) via which it rests against said base wall (4).
5. Capsule, according to claim 4, **characterized in that** said feet (7) are defined along a circular crown.
6. Capsule, according to claim 5, **characterized in that** said feet (7) are defined by a circular crown provided with notches (8) for the passage of the beverage towards said chamber (10).
7. Capsule, according to any one of the claims from 4 to 6, **characterized in that** said feet comprise radial tabs (9).
8. Capsule, according to claim 3, **characterized in that** said disk (6) rests on projecting parts (11) defined between said base wall (4) and said side wall (3) of said bowl (2).
9. Capsule, according to claim 3, **characterized in that** said disk (6) rests on a projecting part (12) which extends upwards from said base wall (4) of said bowl (2).
10. Capsule, according to claim 3, **characterized in that** said disk (6) is provided with a hole in the centre (13)

engaged by a cone-shaped projecting part (14) which extends upwards from said base wall (4) of said bowl (2).

11. Capsule, according to any one of the previous claims, **characterized in that** said disk (6) is provided with a break-off line (15) so that again due to the pressure of the hot water and/or the temperature of the water and/or the pressure exerted on said bowl (2) by the elements of the percolation chamber said disk (6) ruptures along said break-off line (15) and the beverage thus flows towards the base wall (4) of said bowl (2).

15

20

25

30

35

40

45

50

55

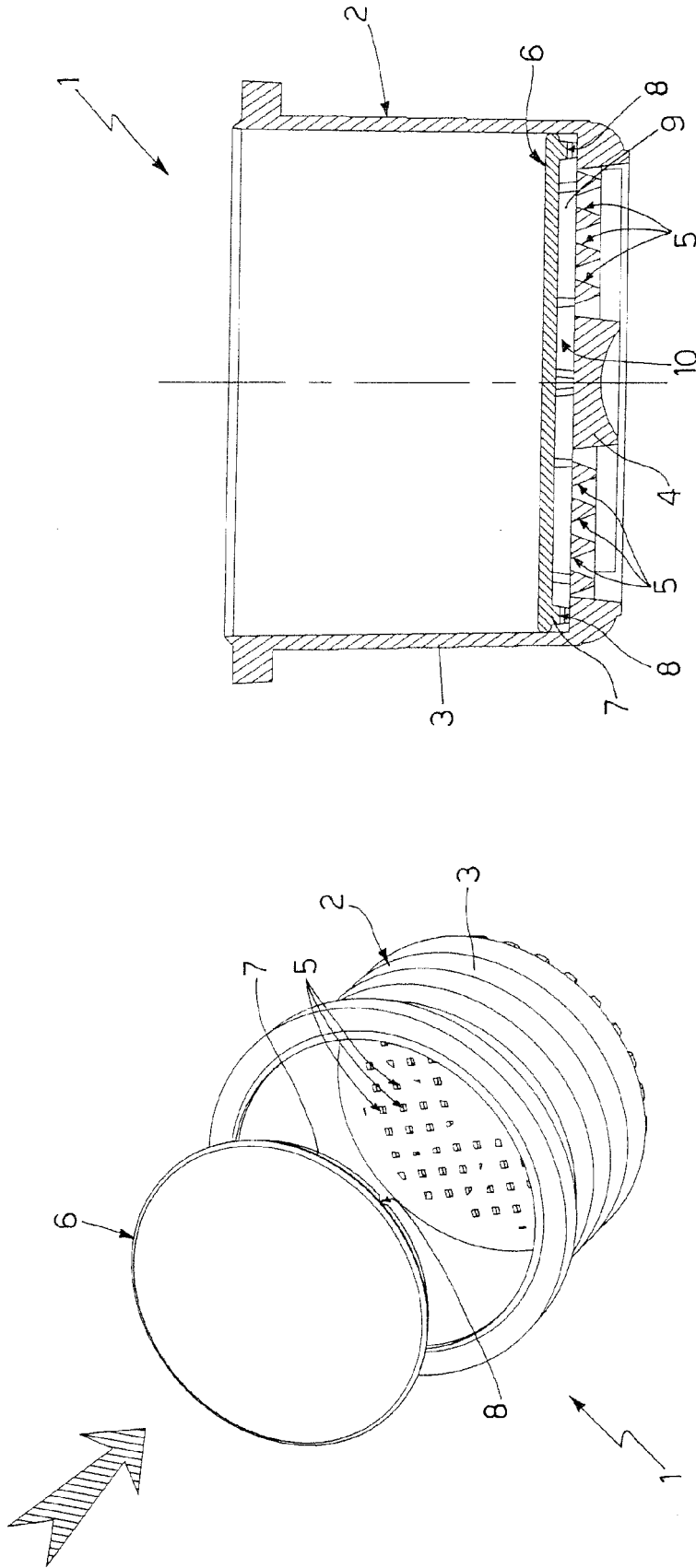

Fig.2

Fig.1

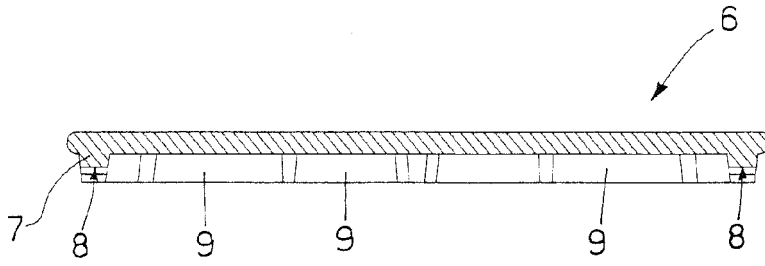

Fig.4

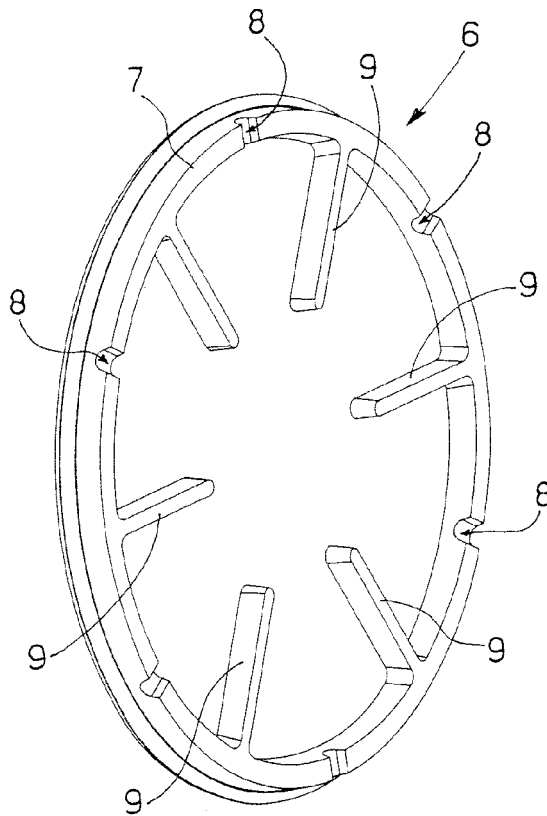

Fig.3

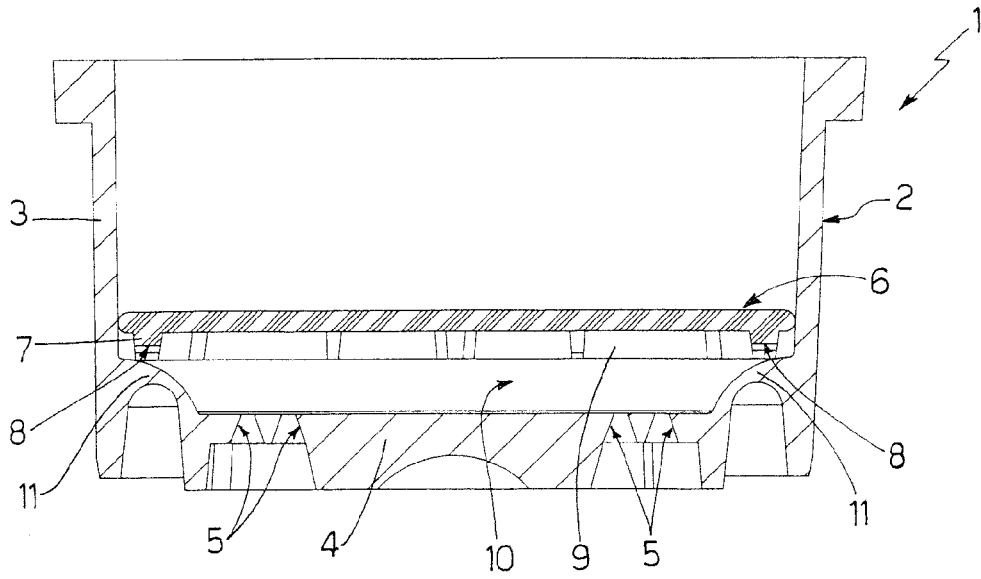

Fig.5

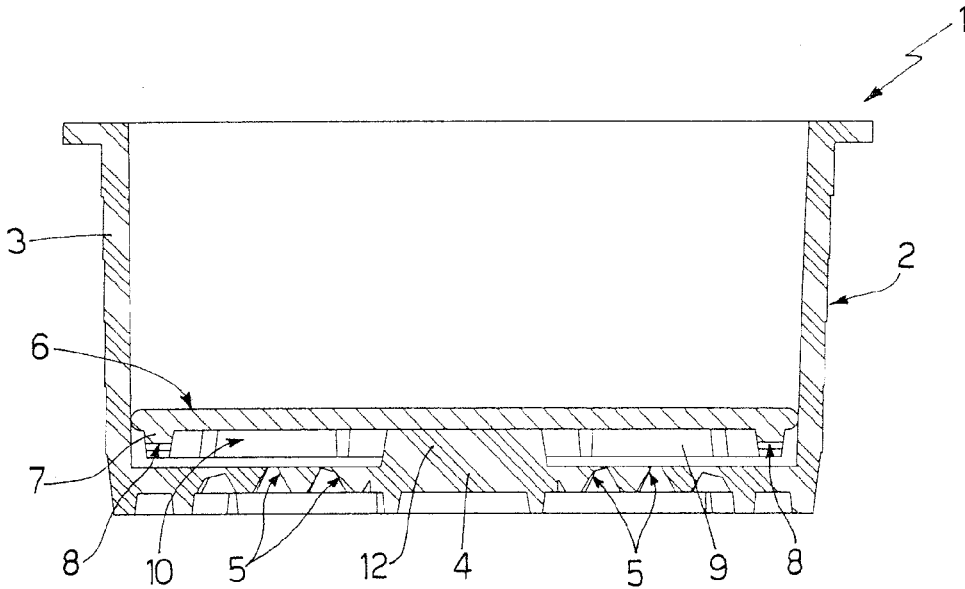

Fig.6

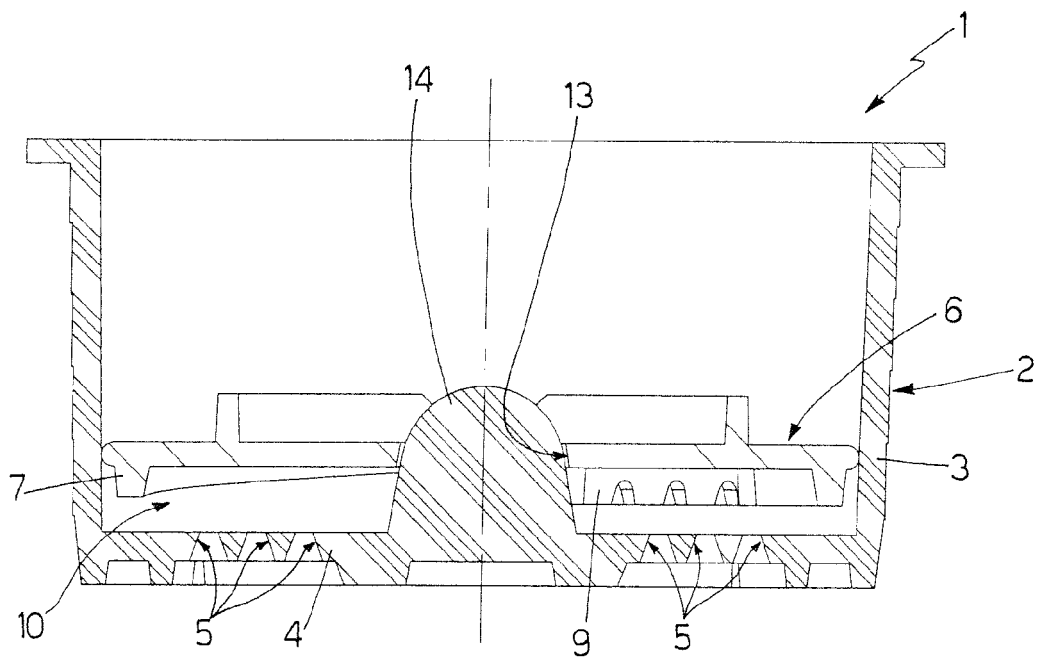
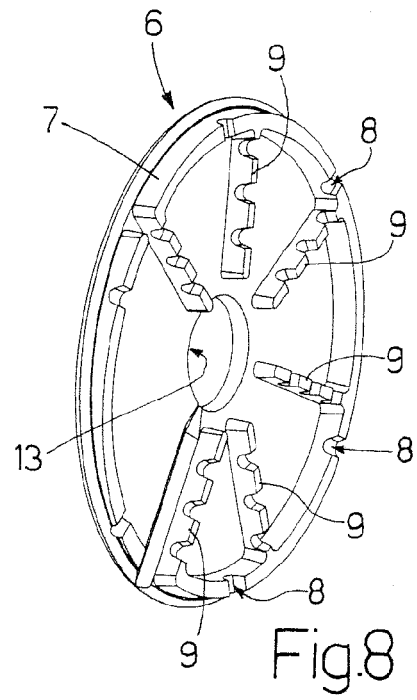
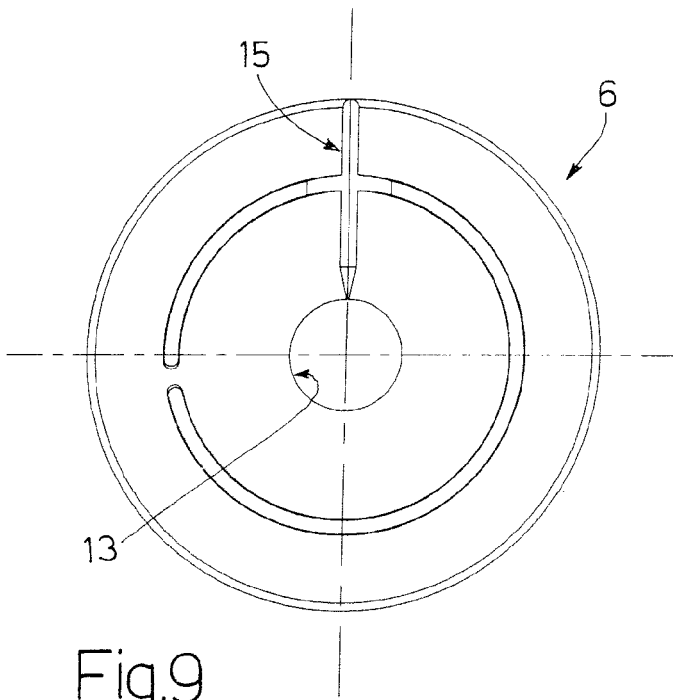

Fig.7



DOCUMENTS CONSIDERED TO BE RELEVANT			
Category	Citation of document with indication, where appropriate, of relevant passages	Relevant to claim	CLASSIFICATION OF THE APPLICATION (IPC)
X	US 4 077 551 A (MANARESI ADRIANA) 7 March 1978 (1978-03-07) * column 2, line 25 - column 3, line 29 *	1-3,8,9	INV. B65D85/804
X	CA 900 870 A (DOVER S PER KUP LTD) 23 May 1972 (1972-05-23) * the whole document *	1-3	
X	FR 1 247 875 A (KOFFIE F ROMBOUITS N V IN HET F) 24 February 1961 (1961-02-24) * the whole document *	1-3	
A	US 3 937 134 A (MOLENAAR ALBERT MEIJLOM ET AL) 10 February 1976 (1976-02-10) * figures *	1	
A	BE 778 730 A1 (DAMME PIERRE E VAN) 16 May 1972 (1972-05-16) * figures *	1	
The present search report has been drawn up for all claims			TECHNICAL FIELDS SEARCHED (IPC)
			B65D
Place of search		Date of completion of the search	Examiner
The Hague		4 August 2008	Fournier, Jacques
CATEGORY OF CITED DOCUMENTS			
X : particularly relevant if taken alone Y : particularly relevant if combined with another document of the same category A : technological background O : non-written disclosure P : intermediate document		T : theory or principle underlying the invention E : earlier patent document, but published on, or after the filing date D : document cited in the application L : document cited for other reasons & : member of the same patent family, corresponding document	

2
EPO FORM 1503 03.82 (FOAC01)

**ANNEX TO THE EUROPEAN SEARCH REPORT
ON EUROPEAN PATENT APPLICATION NO.**

EP 08 15 6048

This annex lists the patent family members relating to the patent documents cited in the above-mentioned European search report. The members are as contained in the European Patent Office EDP file on
The European Patent Office is in no way liable for these particulars which are merely given for the purpose of information.

04-08-2008

Patent document cited in search report	Publication date	Patent family member(s)	Publication date
US 4077551 A	07-03-1978	NONE	
CA 900870 A	23-05-1972	US 3764017 A	09-10-1973
FR 1247875 A	24-02-1961	NONE	
US 3937134 A	10-02-1976	NONE	
BE 778730 A1	16-05-1972	NONE	

EPC FORM P0459

For more details about this annex : see Official Journal of the European Patent Office, No. 12/82