

Aug. 2, 1938.

C. E. WHEELER

2,125,762

OIL OR GAS WELL SNUFFER

Filed Aug. 16, 1937

2 Sheets-Sheet 1

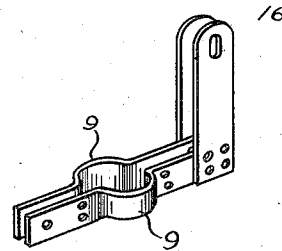
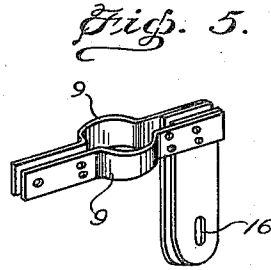
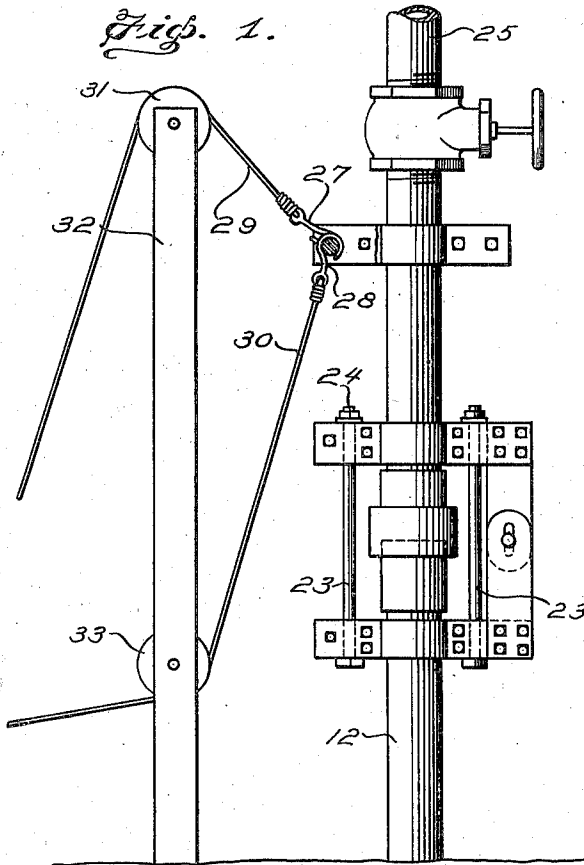

Fig. 6.

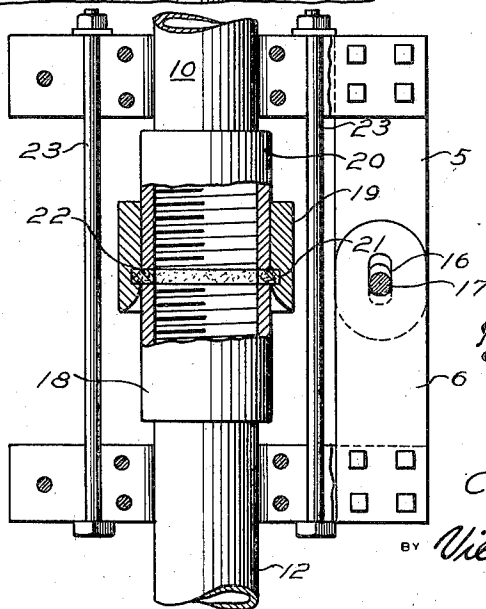

Fig. 4.

Charles E. Wheeler
INVENTOR

BY Victor J. Enns & Co.
ATTORNEYS

Aug. 2, 1938.

C. E. WHEELER

2,125,762

OIL OR GAS WELL SNUFFER

Filed Aug. 16, 1937

2 Sheets-Sheet 2

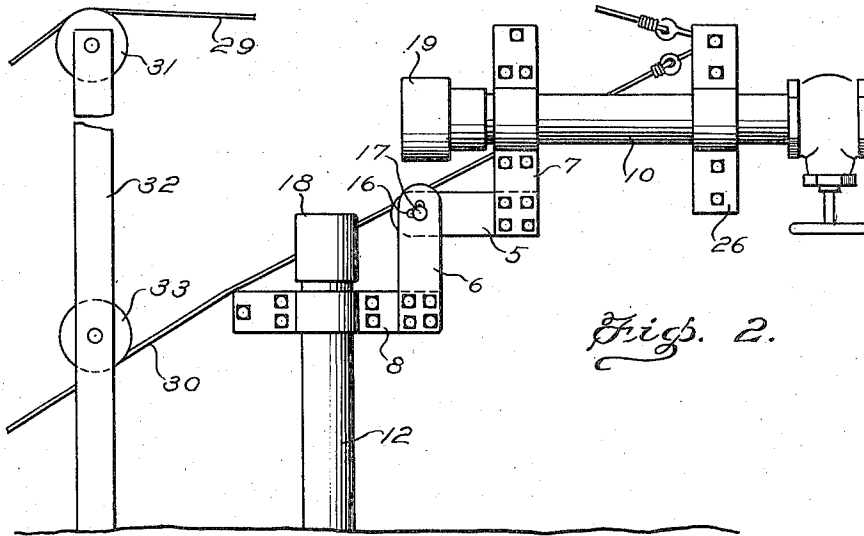

Fig. 2.

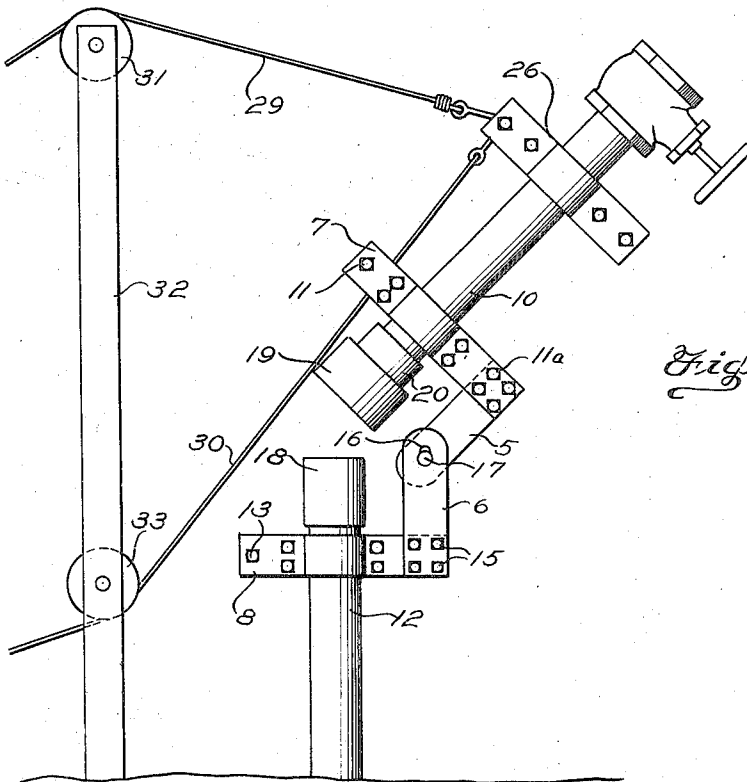

Fig. 3.

Charles E. Wheeler
INVENTOR.

By *Victor J. Evans & Co.*
ATTORNEYS

UNITED STATES PATENT OFFICE

2,125,762

OIL OR GAS WELL SNUFFER

Charles E. Wheeler, Casper, Wyo., assignor of
twenty-five per cent to Marcel L. Gehres and
twenty-five per cent to Bryant S. Cromer, both
of Casper, Wyo.

Application August 16, 1937, Serial No. 159,395

1 Claim. (Cl. 166—15)

My invention relates to improvements in oil or gas well snuffers and more particularly to that class known as control heads for controlling the flow of oil or gas from wells.

One of the principal objects of my invention is to provide a control head for wells equipped with means for readily attaching the same to a well casing.

Another object of my invention is to provide a device of the above described character equipped with means for quickly and effectively bringing the well under control.

A further object of my invention is to provide means of the above described character which is simple in operation, durable in construction and economical in manufacture.

Other objects and advantages will be apparent from the following description, appended claim and annexed drawings.

Referring to the drawings wherein like reference characters designate like parts throughout the several views:

Fig. 1 is a side elevation of my invention illustrating the same in connection with a well casing and in controlled position.

Fig. 2 is a similar view illustrating the control head disengaged from the well casing and in position for immediate connection thereto.

Fig. 3 is a side elevation illustrating the intermediate position of the control head during the engaging or disengaging movement with the casing.

Fig. 4 is a detail view illustrating the control head secured to a well casing.

Figures 5 and 6 are detail perspective views of the hinge member.

In practicing my invention I employ pairs of pivoted hinge members 5 and 6 having pairs of casing engaging arms 7 and 8, respectively, secured thereto. Each pair of the casing engaging arms 7 and 8 are formed with outwardly offset arcuate sections 9 forming a casing receiving sleeve. The arms 7 are clamped about a control head casing 10 by means of suitable bolts and nuts 11. The arms 7 have interposed therebetween at one end the hinge members 5 secured thereto by bolts and nuts 11a.

The arms 8 are secured to a well casing 12 by bolts and nuts 13. The hinge members 6 are secured on the outer face of the arms 8 by nuts and bolts 15.

The pivoted ends of the hinge members are formed with corresponding elongated slots 16 through which is secured a pivot pin 17, the slot permitting relative adjustment between the head

and casing when the head is being secured in position.

The well casing 12, on the upper end thereof adjacent the arms 8, is provided with a coupling 18 of ordinary construction which is adapted to seat within a sleeve 19 carried by a similar coupling 20 secured to the head casing 10. The inner periphery of the sleeve 19, adjacent the lower end thereof, is formed with a circumferentially extending groove 21 having secured therein a gasket 22 constructed of suitable material. Said gasket is of ring shape, the body portion extending without the groove 21 and of a sufficient width to permit the central aperture formed therethrough to register with the apertures formed in the couplings 18 and 20.

When the control head is connected to the well casing in control position, there is provided a pair of stay bolts 23 having nuts 24 for securing the head to the well casing in adjusted position as illustrated in Fig. 4 of the drawings. In this position, the nuts 24 are adjustable to cause the couplings to compress the gasket 22 therebetween and prevent leakage therefrom. The lower face of the sleeve 19 is tapered inwardly to guide the upper end of the coupling 18 into proper seating position.

Secured to the upper end of the head casing is a suitable cutoff valve adapted for connection with an outlet pipe 25 when the control head is in controlled position. Operation of the valve serves to govern and control the flow of liquid or gas through the pipe 25 and to close the end of the head casing 10 when the occasion warrants.

The casing 10 has secured thereto, intermediate of the valve and arms 7, a pair of similar arms 26 clamped thereon by means of bolts and nuts. Attached to one of the bolts, on the side opposite the hinge members, are a pair of hooks 27 and 28 to which are attached operating cables 29 and 30 respectively. The cable 29 engages a pulley 31 rotatably supported by a standard 32 located adjacent the casing 12, and the cable 30 engages a similar pulley 33 mounted on the standard subjacent the pulley 31.

The pulley 31 is mounted on the standard a sufficient distance above the horizontal axis of the control head casing, when in the non-operating position illustrated in Fig. 2, and the pulley 33 is mounted on the standard somewhat below the horizontal plane of the sleeve 19.

When a well is running wild and it is desired to place the same under control, the arms 8 are attached to the well casing, placing the parts in the position illustrated in Fig. 2. Pull on the

cable 29 about the pulley 31 serves to pivot the control head about the pivot pin 17 and raise the same upwardly. When the control head reaches the intermediate position as illustrated in Fig. 3, the cable 30 is then brought into operation to continue the movement of the control head to engaging or control position with the coupling 18 carried by the casing 12. When the sleeve 19 engages the coupling 18, the stay bolts 23 are then applied to lock the parts together and pull on the cable 30 may then be released. In this position, the pipe 25 may be secured to the valve and the valve operated to permit the flow of liquid or gas from the well.

From the foregoing, it will be apparent that my invention provides a simple and effective means for bringing wells under control and that the same may lend itself to other uses and adaptations without departing from the spirit of the invention or scope of the appended claim.

Having described my invention, what I claim is:

In combination with a well casing having an upper end section, a well snuffer device comprising a control head casing equipped with a

coupling on the lower end thereof, a sleeve fixed to said coupling and having a lower section extending below the lower end of the coupling, said sleeve formed with an interior circumferentially extending groove adjacent said lower section, a gasket mounted in said groove for effecting a seal between said coupling and said well casing, said lower section fashioned with an arcuate shaped circumferentially extending inner face for guiding said lower section over the upper section of said well casing, pairs of relatively adjustable hinged arms clamped to said control head and said well casing respectively and permitting vertical adjustment of said control head relative to said well casing, means connected to said control head above said coupling for pivoting said control head above said well casing for connection with the latter through the medium of said sleeve, and bolts equipped with nuts and extending through the respective pairs of arms for adjusting said control head on said well casing in a manner to compress said gasket and thereby seal said sleeve on said upper end of said well casing.

CHARLES E. WHEELER. 25