

(19) World Intellectual Property Organization
International Bureau



(43) International Publication Date
21 April 2011 (21.04.2011)

(10) International Publication Number
WO 2011/045617 A1

(51) International Patent Classification:
A61L 9/12 (2006.01)

Reckitt Benckiser, Dansom Lane, Hull Yorkshire HU8 7DS (GB).

(21) International Application Number:
PCT/GB2010/051749

(74) Agents: **CARLIN, Robert G** et al.; Reckitt Benckiser Corporate Services Limited, Legal Department - Patents Group, Dansom Lane, Hull Yorkshire HU15 1PT (GB).

(22) International Filing Date:
18 October 2010 (18.10.2010)

(81) Designated States (unless otherwise indicated, for every kind of national protection available): AE, AG, AL, AM, AO, AT, AU, AZ, BA, BB, BG, BH, BR, BW, BY, BZ, CA, CH, CL, CN, CO, CR, CU, CZ, DE, DK, DM, DO, DZ, EC, EE, EG, ES, FI, GB, GD, GE, GH, GM, GT, HN, HR, HU, ID, IL, IN, IS, JP, KE, KG, KM, KN, KP, KR, KZ, LA, LC, LK, LR, LS, LT, LU, LY, MA, MD, ME, MG, MK, MN, MW, MX, MY, MZ, NA, NG, NI, NO, NZ, OM, PE, PG, PH, PL, PT, RO, RS, RU, SC, SD, SE, SG, SK, SL, SM, ST, SV, SY, TH, TJ, TM, TN, TR, TT, TZ, UA, UG, US, UZ, VC, VN, ZA, ZM, ZW.

(25) Filing Language: English

(26) Publication Language: English

(30) Priority Data:
0918119.9 16 October 2009 (16.10.2009) GB

(71) Applicant (for all designated States except US):
RECKITT & COLMAN (OVERSEAS) LIMITED [GB/GB]; 103-105 Bath Road, Slough Berkshire SL1 3UH (GB).

(72) Inventors; and

(75) Inventors/Applicants (for US only): **AN, Yuan** [CN/CN]; Reckitt Benckiser, 5th Floor, Raffles City Beijing Office Tower, No. 1, Dongzhimen South Street, Dongcheng District Beijing 10007 (CN). **BLAGG, Adrian** [GB/GB]; Reckitt Benckiser, Dansom Lane, Hull Yorkshire HU8 7DS (GB). **MARRS, Paul** [GB/GB]; Reckitt Benckiser, Dansom Lane, Hull Yorkshire HU8 7DS (GB). **SOUTHERN, Louise** [GB/GB]; Reckitt Benckiser, Dansom Lane, Hull Yorkshire HU8 7DS (GB). **TOYNE, Suzanne** [GB/GB]; Reckitt Benckiser, Dansom Lane, Hull Yorkshire HU8 7DS (GB). **WITTY, Chris** [GB/GB]; Reckitt Benckiser, Dansom Lane, Hull Yorkshire HU8 7DS (GB). **WOOLLEY, Simon** [GB/GB];

(84) Designated States (unless otherwise indicated, for every kind of regional protection available): ARIPO (BW, GH, GM, KE, LR, LS, MW, MZ, NA, SD, SL, SZ, TZ, UG, ZM, ZW), Eurasian (AM, AZ, BY, KG, KZ, MD, RU, TJ, TM), European (AL, AT, BE, BG, CH, CY, CZ, DE, DK, EE, ES, FI, FR, GB, GR, HR, HU, IE, IS, IT, LT, LU, LV, MC, MK, MT, NL, NO, PL, PT, RO, RS, SE, SI, SK, SM, TR), OAPI (BF, BJ, CF, CG, CI, CM, GA, GN, GQ, GW, ML, MR, NE, SN, TD, TG).

Published:

— with international search report (Art. 21(3))

(54) Title: AIR TREATMENT AGENT DISPENSER WITH IMPROVED ODOUR SENSOR FUNCTIONALITY

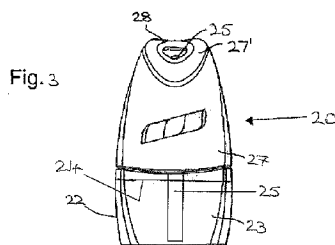

(57) Abstract: A dispensing device for at least one air treatment agent is described herein, the dispensing device comprises: a housing having one or more walls to define an interior adapted to receive at least one removable container of air treatment agent at least partially therein; and within said housing the device comprises, an airborne agent detector means operable to detect airborne agents in the air, wherein said means are provided with at least one aperture to the exterior of the device to permit, in use, air from outside of the device to enter said airborne agent detector means; receiving means for receiving said at least one container of air treatment agent; emanation means adapted, in use, to emanate the air treatment agent from the device through one or more exit orifices in the housing, control means in communication with the emanation means and in communication with said airborne agent detector means; characterised in that said airborne agent detector means is substantially completely isolated from any fluid present in the interior of the housing such that any fluid present in the interior of the housing is substantially completely prevented from passing through said one or more housing walls to be detectable by the airborne agent detector means.

WO 2011/045617 A1

Air Treatment Agent Dispenser with Improved Odour Sensor Functionality

Field of the Invention

The present invention relates to an emanation device that is configured to adapt the emanation of a fluid into the surrounding environment based on a determination of the characteristics of the surrounding environment and particularly, but not exclusively, for the emanation of air treatment agents such as fragrances, deodorizing and/or pest control materials.

Background

Devices are known in which a bottle of volatile liquid has a upwardly projecting wick and a heater is located in the vicinity of the upper end of the wick to accelerate the evaporation of volatile liquid from the wick. The bottle, wick and heater are retained within a housing which carries an electric plug. To operate the heater the device is plugged into a wall socket. Devices of this type commonly claim to allow control of the rate of evaporation of the volatile liquids, for example, by varying the distance between the heater and the wick.

Devices are also known in which an aerosol air freshener is held within an automatic spraying device. A powered mechanism actuates the valve on the aerosol to periodically emit a spray of the air freshener. Devices of this type commonly claim to allow control of the amount of spray over a fixed time period by the consumer being able to vary the time period between emissions. Such automatic spraying devices are typically unable to provide adjustment in response to external stimuli.

Known prior art devices suffer from the drawback of efficiency and convenience. Typically the user has to manually change the apparatus from "normal" to "boost" mode, and then to switch it back to "normal" mode when this effect is no longer necessary (e.g. when the room is empty, or at night). Given the typical location of sources of electrical supply on walls (at a low level near the floor) or placement of electrical devices, this makes the switching process inefficient and inconvenient.

Timed devices are available which are configured to release air treatment agent at user-defined time periods but these device are not capable of dynamically adjusting their operation to take account of changes in the surrounding environment.

In order to overcome some of the drawbacks associated with a device having a timer function, devices consisting of a combination of a timed functional with a motion sensor functional have been made available and go some way to addressing this problem, however, increased motion

surrounding the device does not necessarily linearly equate to a need for increased air treatment agent.

To improve the known devices yet further to make them truly adaptive to their surrounding environment it has been suggested that an odour sensor could be included with such devices such that when the device's 'electronic nose' detects malodour or the like air treatment agent could be emanated, however, such devices are fraught with sensitivity and reliability issues which renders them largely unsuitable for mass commercialisation.

There is a need, therefore, for a device which overcomes the defects of the prior art.

Summary of Invention

According to a first aspect of the present invention there is provided therefore a dispensing device for at least one air treatment agent, the dispensing device comprising:

a housing having one or more walls to define an interior adapted to receive at least one removable container of air treatment agent at least partially therein; and within said housing the device comprises:

an airborne agent detector means operable to detect airborne agents in the air, wherein said means are provided with at least one aperture to the exterior of the device to permit, in use, air from outside of the device to enter said airborne agent detector means;

receiving means for receiving said at least one container of air treatment agent;

emanation means adapted, in use, to emanate the air treatment agent from the device through one or more exit orifices in the housing;

control means in communication with the emanation means and in communication with said airborne agent detector means;

characterised in that said airborne agent detector means is substantially completely isolated from any fluid present in the interior of the housing such that any fluid present in the interior of the housing is substantially completely prevented from passing through said one or more housing walls to be detectable by the airborne agent detector means.

The housing preferably comprises a bottom wall, a top wall remote therefrom and one or more side walls therebetween. The one or more side walls preferably consist of a front wall, a rear wall opposed thereto and a left side wall and a right side wall between said front and rear walls. Most preferably the top wall is angled such it slopes downwardly toward the front wall. The exit orifice(s) is preferably provided in the top wall and/or in the side wall(s) at a position substantially adjacent to the top wall. In one most preferred arrangement the exit orifice(s) is provided in the sloping top wall such that air treatment agent emanated from the device, in use, is directed in a

generally upward direction or a generally upward and forward direction perpendicular to the slope of the top wall. In an alternatively preferred arrangement the exit orifice(s) is provided in the front wall preferably located in a part of said front wall that is closer to the top wall than the bottom wall such that air treatment agent emanated from the device, in use, is directed in a generally forward direction at a height that may be suitable to permit the air treatment agent to be well dispersed in the surrounding environment.

Preferably the at least one aperture for the airborne agent detector means is spaced away from the one or more exit orifices. In one preferred arrangement the at least one aperture may be located in a housing wall that is substantially perpendicular with the housing wall of the exit orifice(s). In an alternatively preferred arrangement the at least one aperture may be located in a housing wall that is substantially opposite to the housing wall of the exit orifice(s). More preferably the at least one aperture is located in the side wall(s) of the housing and, even more preferably, is located in the rear wall.

The housing is preferably provided with a concave recess in a wall thereof that extends into the interior of the housing. The concave recess is preferably sized to receive the airborne agent detector means therein. The concave recess may be provided with a cover that is sized to fill the recess and to substantially follow the shape and/or contour of the side wall, and wherein said cover comprises the at least one aperture. In a preferred arrangement the airborne agent detector means is located within the recess and the cover is substantially permanently sealed to the adjacent side walls to substantially completely prevent ingress of any unwanted materials into the recess other than through the aperture(s) in the cover, and even more preferably completely prevent ingress of any unwanted materials into the recess other than through the aperture(s) in the cover.

Providing the airborne agent detector means within the recess in order to substantially completely isolate it from the interior of the housing has been found to be particularly advantageous insofar as the device may be better protected against false detections by said detector means due to the air treatment agent emanated by the device. With many known devices when the air treatment agent is emanated small quantities of the emanated agent are not successfully emanated into the surrounding environment but instead can get trapped within the device or impinge on the housing walls to circulate inside the device and/or pool inside the device and subsequently evaporate within the device. Without the isolation of the detector means the trapped emanated agent is able to interfere with, and in some cases completely saturate, the detector means such that it is rendered almost completely incapable of reading variations in airborne agents in the environment surrounding the device. Exposure to such high levels of detectable material, and particularly

prolonged exposure, may also lead to problems associated with loss of sensitivity, detector means contamination, reduction of detector means lifetime and, ultimately, loss of detector means functionality.

The airborne agent detector means may be configured to wirelessly communicate with the control means in order to preserve the integrity of the recess against ingress of trapped emanated air treatment agent. Alternatively, a small conduit into the recess may be provided to permit a wired communication between the airborne agent detector means and the control means wherein any gaps between the conduit and the wire(s) is substantially completely sealed, and preferably completely sealed, to prevent the ingress of trapped emanated air treatment agent into the recess.

The aperture(s) may be provided with a filter membrane to prevent or substantially prevent particulate contamination of the airborne agent detector means whilst allowing gas diffusion therethrough. The filter membrane may be a plastics material with suitable diffusion properties such as a polyethylene membrane.

The device may be provided with a movable closure means which is configured to close the aperture(s) to the airborne agent detector means to the outside environment shortly before the device emanates an air treatment agent and, preferably said closure means remains closed for a period of time after emanation has occurred. It may be advantageous for the closure means to keep the aperture(s) closed for a period of time after emanation to allow the initial high concentration of air treatment agent surrounding the device immediately after emanation to subside as the agent emanates further into the surrounding environment in order to prevent false detections of airborne agent by the detector means. Preferably the closure means closes the aperture(s) between 1 to 60 seconds before emanation, and more preferably 1 to 30 seconds before emanation, and even more preferably 1 to 10 seconds before emanation. Preferably the closure means moves away from the aperture(s) to permit air from the surrounding environment to enter the aperture(s) between 1 second to 30 minutes after emanation, and more preferably 5 seconds to 15 minutes after emanation, and even more preferably 10 seconds to 10 minutes after emanation, and most preferably 15 seconds to 5 minutes after emanation.

The housing wall(s) may be provided with an outwardly extending protrusion adjacent to the aperture(s) communicating with the airborne agent detector means in order to prevent an emanated air treatment agent from entering the aperture(s) to falsely trigger the airborne agent detector means and/or potentially saturate the airborne agent detector means. Preferably the

outwardly extending protrusion is provided in the form of a cowl located above the aperture(s) the divert any air treatment agent away from the aperture(s).

Preferably the airborne agent detector means comprises at least one odour sensor means. The odour sensor may comprise one or more metal oxide semiconductor sensors and/or one or more metal oxide sensors. The at least one odour sensor means may be combined with one or more additional sensors from the list of: a motion sensor; a person sensor; a light sensor; a sound sensor; a humidity sensor; a smoke sensor; a temperature sensor.

In order for any metal oxide semiconductor/metal oxide odour sensor to be operational the sensor must heat up to an operational temperature to facilitate suitably active surface chemistry on said sensor, typically this temperature is in the order of 300 to 380°C. The need to access such high operation temperatures makes devices containing such sensors consume large amounts of energy. It is a further object of the present invention to improve the energy consumption of devices containing oxide semiconductor/metal oxide odour sensor(s) and to this end the inventors have realised that it is possible to achieve this aim via pulsing the energy applied to said sensor(s).

In one preferred arrangement power is applied to the sensor(s) substantially continuously in order to get the sensor(s) to an operational temperature to ensure that said sensor(s) surface chemistry is suitably active to detect airborne agents and thereafter the power is applied intermittently to the sensor(s) to keep the sensor(s) at or close to an operational temperature and/or to ensure that said sensor(s) surface chemistry is suitably active to detect airborne agents.

In another preferred embodiment after the power has been applied to the sensor(s) substantially continuously to get the sensor(s) to an operational temperature to ensure that said sensor(s) surface chemistry is suitably active to detect airborne agents, thereafter the power is applied intermittently to the sensor(s) to keep the sensor(s) at an operational temperature and/or to ensure that said sensor(s) surface chemistry is suitably active to detect airborne agents such that the odour sensor may substantially continuously or routinely measure the to quantities of airborne agents entering the aperture(s).

In an alternatively preferred embodiment after the power has been applied to the sensor(s) substantially continuously to get the sensor(s) to an operational temperature to ensure that said sensor(s) surface chemistry is suitably active to detect airborne agents, thereafter the power is applied generally intermittently to the sensor(s) to keep the sensor(s) close to an operational temperature and/or to ensure that said sensor(s) surface chemistry is suitably active to detect

airborne agents. Within the period of intermittent power application may be periods of continual power application and/or increased power application to temporally place the sensor(s) at the operation temperature and/or to ensure that said sensor(s) surface chemistry is suitably active to detect airborne agents, wherein the odour sensor is arranged to cooperate with this application of power thereto to only measure the quantities of airborne agents entering the aperture(s) when the sensor(s) is at the operational temperature and/or to ensure that said sensor(s) surface chemistry is suitably active to detect airborne agents in the power application cycle.

In a further alternatively preferred embodiment after the power has been applied to the sensor(s) substantially continuously to get the sensor(s) to an operational temperature to ensure that said sensor(s) surface chemistry is suitably active to detect airborne agents, thereafter follows a period of no application of power, wherein the non-application of power is followed by the application of power substantially continually to get the sensor(s) to an operational temperature to ensure that said sensor(s) surface chemistry is suitably active to detect airborne agents, and the cycle continues in accordance with the same pattern throughout the operation of the device.

Preferably the once the metal oxide semiconductor/metal oxide odour sensor to has been heated up to an operational temperature the pulses of power may last for a 5 to 1000ms period with an off-period lasting between 0.5 to 10 seconds, and more preferably the pulses of power last for a 5 to 250ms period with an off-period lasting between 0.5 to 7.5 seconds, and even more preferably the pulses of power last for a 5 to 100ms period with an off-period lasting between 0.5 to 5.5 seconds, and most preferably the pulses of power last for a 5 to 60ms period with an off-period lasting between 0.5 to 3.5 seconds, ideally the pulses of power last for substantially 35ms with an off-period lasting for substantially 2.2 seconds.

In the context of the present invention and for the avoidance of doubt "operational temperature" is used in relation to the present invention to relate to the temperatures that the sensor(s) must access to facilitate suitably active surface chemistry on said sensor. For the further avoidance of doubt, in the context of the present invention "close to an operational temperature" is understood to mean the temperature is only permitted to drop below an operation temperature defined by the duration of time (as defined above) that it would take the device under the application of power to the sensor to heat up to an operational temperature. The skilled person would understand the boundaries of "close" to be based on how the system had been tuned when the sensor(s) of the device may be powered 5 to 1000ms period with an off-period lasting between 0.5 to 10 seconds; such that a temperature would not be defined as "close to an operational temperature" if the sensor was not capable of reaching an operational temperature within the operational boundaries the device was tuned to.

In order to maintain and/or improve the sensitivity of the airborne agent detector means and prevent the false triggering thereof, once a quantity of air treatment agent has been emanated the control means may prevent the airborne detection means from operating for a period of time to allow the initial high concentration of air treatment agent surrounding the device immediately after emanation to subside as the agent emanates further into the surrounding environment in order to prevent false detections of airborne agent by the detector means. Preferably the control means is operable to disable the airborne agent detector means from operating for between 1 second to 30 minutes after emanation, and more preferably 5 seconds to 15 minutes after emanation, and even more preferably 10 seconds to 10 minutes after emanation, and most preferably 15 seconds to 5 minutes after emanation, and ideally for substantially between 90 to 180 seconds after emanation; by virtue of this arrangement the airborne agent detector will also be conserving power consumption which is particularly useful if the device is to be non-mains electric powered. Alternatively the control means may be operable to ignore and/or dismiss signals from the airborne agent detector means for between 1 second to 30 minutes after emanation, and more preferably 5 seconds to 15 minutes after emanation, and even more preferably 10 seconds to 10 minutes after emanation, and most preferably 15 seconds to 5 minutes after emanation, and ideally for substantially between 90 to 180 seconds after emanation.

In order to further maintain and/or improve the sensitivity of the airborne agent detector means the control means may be provided with auto-ranging functionality whereby said functionality is operable to select the correct range of the signals received from the airborne agent detector in order to ensure consistent response is maintained to further airborne agents whilst the detector means is already under the influence of previously existing airborne agent(s) or other environmental factors.

Preferably the at least one airborne agent detector operable, in use, to detect whether the current airborne agent level deviates from a background airborne agent level detected by more than a predetermined amount, wherein the background airborne agent level and the current airborne agent level is calculated by the device, preferably by the control means.

Preferably, the control means are operable to calculate the current airborne agent level by calculating an average of a predetermined number of most recent readings of the airborne agent detector means. Preferably, two to five of the most recent readings, more preferably three of the most recent readings.

The control means may be operable to calculate the deviation of the current airborne agent level from the background level by means of a subtraction of one from the other, and/or by means of a ratio of one to the other.

Preferably, the deviation is calculated by subtracting the background level from the current airborne agent level and dividing that amount by the background level value. The result may be multiplied by a constant, for ease of display and/or use.

Unlike several known prior art devices the device of the present invention does not operate using a pre-defined value for the background airborne agent level, rather the device of the present invention calculates this level and uses this calculated level to control the release of the at least one air treatment agent. This arrangement may be advantageous as the device is operable to adapt how it releases the one or more air treatment agent depending on the characteristics of the surrounding environment in which it is used.

Preferably, the control means are operable to calculate the background airborne agent level by calculating an average of a longer time period than that over which the current airborne agent level is calculated.

Preferably, the background airborne agent level and the current airborne agent level are temporally offset, preferably by at least 5 seconds, more preferably by at least 10 second, more preferably by at least 20 seconds.

Once the device is placed into an operational mode, the background airborne agent level may be an average of the levels of airborne agent detected by the device throughout the duration of that operational mode. In this arrangement the device may better 'learn' the characteristics of its local environment and, during use, will be better able to provide for the release of an air treatment agent(s) when the current airborne agent level deviates from the background level by more than the predetermined amount. If a user wishes to move the device to an alternative location, a user may be encouraged to reset the device from the operational mode, this resetting of the device may have the effect of zeroing the average levels of background agent such that the device is operable to 'learn' the characteristics of its new environment when placed back into the operational mode by calculating the average background agent level from no existing starting point.

Preferably, the control means are operable to calculate the background airborne agent level by calculating an average of a predetermined number of some or all of the most recent readings of

the detector. Preferably 10 to 10,000 of the most recent readings, more preferably 20 to 5,000 of the most recent readings, and most preferably 50 to 1000 of the most recent readings.

The device may be provided with an initial setting mode wherein when the device is first powered up, the control means will automatically calibrate based on the existing background odour when the device is first switched on.

In an alternative or additional arrangement, the control means are preferably operable to calculate the background level based on calculating a series of averages from rolling windows of measurements from the airborne agent detector means. Each rolling window may be an average of between two and ten readings, preferably six readings. Preferably, the windows do not overlap. Preferably, the windows span a time period of between 5 and 30 minutes, preferably between 10 and 25 minutes, preferably between 15 and 20 minutes. There may be approximately 30 to 50 windows.

Preferably, the control means are operable to discard the oldest window when a new window becomes available, preferably taking into account an offset between the current and background levels.

Preferably, the control means are operable to adjust the predetermined level of deviation from the background level that results in air treatment agent being released. The predetermined level may be manually adjustable. The deviation may be a positive or negative deviation.

Where the airborne agent detector means is provided in the form of one or more metal oxide semiconductor/metal oxide odour sensor said sensor(s) may be provided with one or more resistors in series therewith to ensure a consistent output of signal from the sensor(s) as their resistance changes during their operation in response to their detection of airborne agent. Preferably the device is provided with between 3 to 5 dynamic range resistors with a 1 to 300K Ω range.

The emanation means could be provided by one or more known emanation mechanisms for air treatment agents. For instance, where the air treatment agent is contained in a pressurised container with a suitable propellant (such as hydrocarbon propellant, compressed gas, compressed nitrogen, or the like) the emanation mechanism may be the mechanical movement of the container's valve either by direct contact with the valve or by movement of the valve actuator; in this arrangement the container may be a metered dose aerosol to improve the spray performance and reproducibility thereof. Alternatively the pressurised container could be

engaged in the device with its valve held open and an electro-magnetic solenoid is employed to control the release of the air treatment agent. Other suitable emanation means may include, but is not necessarily limited to, one or more heaters, one or more nebulisers, one or more piezo-electric emanation means.

The device is preferably provided with one exit orifice per replaceable container of air treatment agent secured in the device, this arrangement is preferably to prevent cross-contamination of the air treatment agents.

Preferably the container of air treatment agent is received entirely within the housing of the device.

The device may be provided with a user-controlled boost mechanism. In use of the device, the activation of said boost mechanism may substantially immediately cause the dispensing of the at least one air treatment agent.

The airborne agents detected by the airborne agent detector means may be common household odours (and the chemicals which constitute) these malodours. For example: kitchen malodour; bathroom malodour; tobacco smoke; pet odours; mould and/or mildew; body odour; fish; onions; garbage; fragrance from other products (such as detergents, polishes, cleaning products etc). To facilitate such detection the odour sensor means may be operable to detect at least some of the following chemical components: amines and nitrogen compounds; acids and/or sulphur compounds, such as mercaptans, thioacids, thioesters, sulfides, phenols and skatole odours..

The device of any of the above-mentioned aspects may be provided with an indicator wherein said indicator is operable to indicate to a user what function the device is currently performing. The indicator may be operable to provide a visual indication and/or provide an audible indication.

Preferably the indicator is configured to provide a visual indication by emitting light from one or more light sources, preferably one or more LEDs.

The one or more light sources may be adapted to emit a different colour of light to indicate the current function the device is performing. Additionally or alternatively, the one or more light sources may blink or flash to indicate the current function the device is performing.

Alternatively or additionally, the device may be operable to visually indicate the function currently being performed by the device via a screen. The screen may be an LCD screen that is adapted

to provide a message to a user, for instance such messages could include "ON", "SENSING", "MOTION DETECTED", "RESTING", "NORMAL MODE", "DETECTION MODE", "OFF".

The device may be power by mains-supplied electricity and/or be battery powered and/or be powered by solar cells located on the device. Most preferably the device is battery powered.

According to a second aspect of the present invention there is provided therefore a method of improving the sensitivity of a dispensing device with an airborne agent detector mean for at least one air treatment agent, wherein the dispensing device comprises:

a housing having one or more walls to define an interior adapted to receive at least one removable container of air treatment agent at least partially therein; and within said housing the device comprises:

an airborne agent detector means operable to detect airborne agents in the air, wherein said means are provided with at least one aperture to the exterior of the device to permit, in use, air from outside of the device to enter said airborne agent detector means;

receiving means for receiving said at least one container of air treatment agent;

emanation means adapted, in use, to emanate the air treatment agent from the device through one or more exit orifices in the housing;

control means in communication with the emanation means and in communication with said airborne agent detector means;

and wherein said airborne agent detector means is substantially completely isolated from any fluid present in the interior of the housing such that any fluid present in the interior of the housing is substantially completely prevented from passing through said one or more housing walls to be detectable by the airborne agent detector means;

and wherein the method comprises the steps of:

loading a container of air treatment agent into said housing and engaging the receiving means;

placing the device in an operational mode wherein the emanation means engage with the container of air treatment agent to cause a quantity of air treatment agent to emanate from the device;

characterised in that any air treatment agent that remains in the device after the emanation thereof is not capable to emanate from within the device to come into contact with the airborne agent detector which is substantially completely isolated therefrom.

Any of the features described herein may be combined with any of the above aspects in any combination.

Description of an Embodiment

Embodiments of the invention will now be described, by way of example only, with reference to the following drawings in which:

Fig. 1 illustrates a cross sectional view of an autospray device according to the present invention;

Fig. 2 illustrates a rear elevation of an autospray device according to the present invention.

Fig. 3 illustrates a front elevation of a plug-in electrical device according to the present invention;

Fig. 4 illustrates a top elevation of the plug-in electrical device according to the present invention;

Fig. 5 illustrates a cross sectional view of the plug-in electrical device according to the present invention; and

Fig. 6 illustrates a side elevation of a plug-in electrical device according to the present invention;

Fig.1 illustrates a cross-sectional view of an autospray device 1 for the emanation of air treatment agent according to the present invention. The device 1 comprises a housing 2 and Fig. 1, in essence, shows the housing absent the front wall of the housing 2. The front wall of the housing is provided with one or more exit orifices (not shown). The housing is sized to receive a removable container 3 of air treatment agent therein. In Fig. 1 the container 2 of air treatment agent is provided in the form of an aerosol canister containing air treatment agent under pressure, the canister sits on receiving means 4 which in this embodiment are provided in the form of a platform that supports the base of the aerosol. Also illustrated in Fig.1 are the emanation means 5, the control means 6, airborne agent detector means 7 and a power source 8 which is Fig.1 are depicted as a pair of batteries, and these will all be discussed in great detail below.

The emanation means 5 is provided with an arm 9 that is movable between at least two positions, the first of these positions is illustrated in Fig.1 in which the arm is in a raised position above the aerosol canister. The aerosol canister has a valve connected to an actuator 10 via a valve stem 11 therebetween. In the first position the arm 9 is held at least partially above the actuator 10 and the aerosol valve remains in a closed position. In the second position of the arm 9, the emanation means 5 causes the arm to move in a substantially downward direction to depress the actuator 10 toward the valve, the valve stem 11 is depressed and the valve opens to permit air treatment agent to exit from the aerosol canister. Preferably the container 3 is a metered dose aerosol canister which may be advantageous as a single depression of the spray head will release a predefined quantity of fluid from the aerosol canister regardless of the duration of time the actuator is depressed. However, a non-metered dose aerosol may be used in the device 1 as could a non-pressurised container possessing a pump mechanism to spray the air treatment agent therefrom.

Alternatively, the emanation means 5 could take the form of a valve system, such as a solenoid

valve system (not shown). Such a solenoid valve system may work together with a pressurised aerosol engaged therewith. Rather than initiate actuation by movement, the solenoid valve would be energised to initiate the release of a quantity of fluid from the aerosol.

Although not illustrated, the device 1 may be provided with means to receive at least two separate containers of air treatment agent. In this arrangement the device 1 may be provided with additional emanation means to cause the emanation of the agent, or a single set of emanation means 5 to emanate agent from both containers as directed by the control means 6.

The control means 6 is operationally connected to the airborne agent detector means 7 and the emanation means 5 such that it is able to communicate therebetween.

The airborne agent detector means 7 is shown to be located within dotted lines, that is because in Fig.1 the detector means 7 is substantially completely isolated from the interior of the housing such that any fluid present in the interior of the housing is substantially completely prevented from passing through the housing walls 2 to be detectable by the detector means 7.

The housing 2 comprises a bottom wall 2', a top wall 2'', a front wall (not shown) and a rear wall 2'''. The rear wall 2''' is provided with a recess 12 that extends into the interior of the housing 2, the recess 12 being concave in shape when the device is viewed from the angle depicted in Fig.2. The recess 12 is sized to receive the airborne agent detector means 7 therein. The recess is provided with a cover 13 that is sized to fill the recess to and substantially follow the shape and/or contour of the exterior-facing rear wall 2'''. The cover 13 is provided with at least one aperture 14 to permit air outside of the device 1 to enter and its content be analysed by the detector means 7. As shown in Figs. 1 & 2, the airborne agent detector means 7 is located within the recess 12 and the cover 13 is substantially permanently sealed to the adjacent rear wall 2''' to substantially completely prevent ingress of any unwanted materials into the recess other than through the aperture 14 in the cover 13.

The arrangement shown in Figs. 1 & 2 illustrates how the airborne agent detector means 7 is substantially completely isolated from the interior of the housing and this is considered to be advantageous insofar as the device may be better protected against false detections by said detector means 7 due to the air treatment agent erroneously and/or routinely being emanated by the device within the interior of the housing 2. A small conduit 15 into the recess is provided to permit a wired communication between the airborne agent detector means 7 and the control means 6, the gap between the conduit 15 and the wire(s) is sealed to prevent the ingress of trapped emanated air treatment agent into the recess such as with resin or adhesive or the like.

Although not illustrated, the airborne agent detector means 7 could wirelessly communicate with the control means 6 in order to preserve the integrity of recess against ingress of air treatment agent present in the interior of the housing 2.

Although not illustrated the aperture 14 can be filled with a filter membrane to prevent or substantially prevent particulate contamination of the airborne agent detector means whilst allowing gas diffusion therethrough. The filter membrane may be a plastics material with suitable diffusion properties such as a poly ethylene membrane.

It can be seen in Fig.1 that the actuator 10 of the aerosol canister is arranged to spray air treatment agent in a forward direction through the front wall of the housing (not shown) at an angle that is generally parallel or at a slightly elevated angle to the bottom wall 2' of the housing, typically the device 1 will stand on a surface with its bottom wall 2' in contact with said surface. This arrangement ensures that the aperture 14 is spaced away from the exit orifice, and in the arrangement illustrated the aperture 14 is located in a housing wall that is substantially opposite to the housing wall of the exit orifice such that air treatment agent sprayed from the container 2 will not immediately come into contact with the aperture 14.

Turning now to Figs. 3-6 the device 20 is a plug-in device intended to be connected to a mains electricity socket, the device being mounted on or carried by electrical plug formations 21 that extend out of the rear side of the device 20. The device 20 is illustrated in Figs. 3 & 4 with a container 22 of volatile liquid air treatment agent engaged therewith, held in place by receiving means 34. The container 22 has a reservoir portion 23 in the form of a glass bottle containing the air treatment agent 24 and a wick 25 extending from the reservoir 23 to above the top of the bottle through a seal (not shown) and into a chimney means 26 of the device 20. The wick 25 may be substantially cylindrical and the seal is present to retain the air treatment agent 24 within the bottle should the device 20 be knocked over and/or inverted when the container 22 is engaged therewith.

The device 20 has a housing 27 which partially extends over an upper part of the container 22. The top of the housing 27 has a generally circular central exit orifice 28 which is aligned with the intended airflow from the chimney means 26.

The emanation means may be provided in the form of at least one heater means 29 and/or at least one electric fan (not shown). The heating means 29 are illustrated as resistors, such as positive temperature coefficient (PTC) thermistors but said means could be provided by way of a ring heater or the like, or a combination thereof.

Although not illustrated, the device 20 may be provided with means to receive at least two separate containers of liquid 22. In this arrangement the device 20 may be provided with additional emanation means to cause the emanation of the air treatment agent 24.

Most preferably the top wall 27' of the housing 27 is angled such it slopes downwardly toward the front wall 27'' and the exit orifice 28 is provided in the top wall 27'. In use, to be discussed in more detail below, air treatment agent 24 emanated from the device 20 is directed in a generally upward direction or a generally upward and forward direction perpendicular to the slope of the top wall 27'.

The airborne agent detector means 30 is provided in the side wall 27''' generally adjacent the bottom wall 27'''' of the housing 27 located within dotted lines as said detector means 30 is substantially completely isolated from the interior of the housing such that any fluid present in the interior of the housing is substantially completely prevented from passing through the housing walls to be detectable by the detector means 30.

The housing 27 comprises is provided with a recess 31 that extends into the interior of the housing 27, the recess 31 being concave in shape when the device is viewed from the angle depicted in Fig.6. The recess 31 is sized to receive the airborne agent detector means 30 therein. The recess is provided with a cover 32 that is sized to fill the recess to and substantially follow the shape and/or contour of the exterior-facing side wall 27'''. The cover 32 is provided with at least one aperture 33 to permit air outside of the device 20 to enter and its content be analysed by the detector means 30. The airborne agent detector means 30 is located within the recess 31 and the cover 32 is substantially permanently sealed to the adjacent side wall 27''' to substantially completely prevent ingress of any unwanted materials into the recess other than through the aperture 33 in the cover 32.

As with the arrangement shown in Figs. 1 & 2, device 20 is arranged such that the airborne agent detector means 30 is substantially completely isolated from the interior of the housing and this is considered to be advantageous insofar as the device may be better protected against false detections by said detector means 30 due to the air treatment agent erroneously and/or routinely being emanated by the device 20 within the interior of the housing. A small conduit (not shown) into the recess is provided to permit a wired communication between the airborne agent detector means 30 and a control means (not shown), the gap between the conduit and the wire(s) is sealed to prevent the ingress of trapped emanated air treatment agent into the recess such as with resin or adhesive or the like. Although not illustrated, the airborne agent detector means 30

could wirelessly communicate with the control means in order to preserve the integrity of recess 31 against ingress of air treatment agent 24 present in the interior of the housing.

Although not illustrated the aperture 33 can be filled with a filter membrane to prevent or substantially prevent particulate contamination of the airborne agent detector means whilst allowing gas diffusion therethrough. The filter membrane may be a plastics material with suitable diffusion properties such as a poly ethylene membrane.

For both devices 1, 20 illustrated, the air borne agent detector means 7, 30 generally comprises at least one odour sensor means, and preferably one or more metal oxide semiconductor sensors and/or one or more metal oxide sensors.

The mode of operation of the devices 1, 20 and the inter-relation of the components will now be explained.

In order for any metal oxide semiconductor/metal oxide odour sensor to be operational the sensor must heat up to an operational temperature, typically this temperature is in the order of 300 to 350°C. The devices 1, 20 may be arranged such that their control means allows power to be applied to the sensor(s) substantially continuously in order to get the sensor(s) to an operational temperature and thereafter the power is applied intermittently to the sensor(s) to keep the sensor(s) at, or close to, an operational temperature such that the odour sensor may substantially continuously or routinely measure the to quantities of airborne agents entering the aperture 14, 33.

Once the metal oxide semiconductor/metal oxide odour sensor to has been heated up to an operational temperature the pulses of power may last for a 5 to 1000ms period with an off-period lasting between 0.5 to 10 seconds, and more preferably the pulses of power last for a 5 to 250ms period with an off-period lasting between 0.5 to 7.5 seconds, and even more preferably the pulses of power last for a 5 to 100ms period with an off-period lasting between 0.5 to 5.5 seconds, and most preferably the pulses of power last for a 5 to 60ms period with an off-period lasting between 0.5 to 7.5 seconds, ideally the pulses of power last for substantially 35ms with an off-period lasting for substantially 2.2 seconds.

To improve and/or maintain the sensitivity of the airborne agent detector means 7, 30 and prevent the false triggering thereof, once a quantity of air treatment agent has been emanated the control means prevents the airborne detection means 7, 30 from operating for a period of time to allow the initial high concentration of air treatment agent surrounding the device immediately after

emanation to subside as the agent emanates further into the surrounding environment in order to prevent false detections of airborne agent by the detector means 7, 30. Preferably the control means is operable to disable the airborne agent detector means 7, 30 from operating for between 1 second to 30 minutes after emanation, and more preferably 5 seconds to 15 minutes after emanation, and even more preferably 10 seconds to 10 minutes after emanation, and most preferably 15 seconds to 5 minutes after emanation, and ideally for substantially 100 seconds after emanation; by virtue of this arrangement the airborne agent detector 7, 30 will also be conserving power consumption which is particularly useful if the device depicted in Figs.1 & 2 which may be non-mains electric powered.

In use the control means is arranged to analyse signals received from the airborne agent detector means 7, 30 to detect whether the current airborne agent level deviates from a background airborne agent level detected by more than a predetermined amount, wherein the background airborne agent level and the current airborne agent level is calculated by said control means.

The control means are operable to calculate the current airborne agent level by calculating an average of a predetermined number of most recent readings of the airborne agent detector means 7, 30. Preferably, two to five of the most recent readings, more preferably three of the most recent readings.

The control means may be operable to calculate the deviation of the current airborne agent level from the background level by means of a subtraction of one from the other, and/or by means of a ratio of one to the other.

Preferably however, the deviation is calculated by subtracting the background level from the current airborne agent level and dividing that amount by the background level value. The result may be multiplied by a constant, for ease of display and/or use.

The control means are operable to calculate the background airborne agent level by calculating an average of a longer time period than that over which the current airborne agent level is calculated. To improve the sensitivity the background airborne agent level and the current airborne agent level are temporally offset, preferably by at least 5 seconds, more preferably by at least 10 second, more preferably by at least 20 seconds.

Once the device 1, 20 is placed into an operational mode, the background airborne agent level may be an average of the levels of airborne agent detected by the device throughout the duration of that operational mode. In this arrangement the device 1, 20 may better 'learn' the

characteristics of its local environment and, during use, will be better able to provide for the release of an air treatment agent(s) when the current airborne agent level deviates from the background level by more than the predetermined amount.

If a user wishes to move the device 1, 20 to an alternative location, a user may be encouraged to reset the device from the operational mode, this resetting of the device may have the effect of zeroing the average levels of background agent such that the device is operable to 'learn' the characteristics of its new environment when placed back into the operational mode by calculating the average background agent level from no existing starting point.

The control means are operable to calculate the background airborne agent level by calculating an average of a predetermined number of some or all of the most recent readings of the detector, preferably 10 to 10,000 of the most recent readings.

The device 1, 20 may be provided with an initial setting mode wherein when the device is first powered up, the control means will automatically calibrate based on the existing background odour when the device is first switched on. Thereafter the control means are operable to calculate the background level based on calculating a series of averages from rolling windows of measurements from the airborne agent detector means. Each rolling window may be an average of between two and ten readings, preferably six readings. Preferably, the windows do not overlap. Preferably, the windows span a time period of between 5 and 30 minutes, preferably between 10 and 25 minutes, preferably between 15 and 20 minutes. There may be approximately 30 to 50 windows. The control means are operable to discard the oldest window when a new window becomes available, preferably taking into account an offset between the current and background levels.

Preferably, the control means are operable to adjust the predetermined level of deviation from the background level that results in air treatment agent being released. The predetermined level may be manually adjustable. The deviation may be a positive or negative deviation.

Where the airborne agent detector means is provided in the form of one or more metal oxide semiconductor/metal oxide odour sensor said sensor(s) may be provided with one or more resistors in series therewith to ensure a consistent output of signal from the sensor(s) as their resistance changes during their operation in response to their detection of airborne agent. Preferably the device is provided with between 3 to 5 dynamic range resistors with a 1 to 300K Ω range.

The device 1, 20 may be provided with a user-controlled boost mechanism (not shown). In use of the device, the activation of said boost mechanism may substantially immediately cause the dispensing of the at least one air treatment agent.

All of the features disclosed in this specification (including any accompanying claims, abstract and drawings), and/or all of the steps of any method or process so disclosed, may be combined in any combination, except combinations where at least some of such features and/or steps are mutually exclusive.

Each feature disclosed in this specification (including any accompanying claims, abstract and drawings) may be replaced by alternative features serving the same, equivalent or similar purpose, unless expressly stated otherwise. Thus, unless expressly stated otherwise, each feature disclosed is one example only of a generic series of equivalent or similar features.

The invention is not restricted to the details of the foregoing embodiment(s). The invention extends to any novel one, or any novel combination, of the features disclosed in this specification (including any accompanying claims, abstract and drawings), or to any novel one, or any novel combination, of the steps of any method or process so disclosed.

Claims

1. A dispensing device for at least one air treatment agent, the dispensing device comprising:
a housing having one or more walls to define an interior adapted to receive at least one removable container of air treatment agent at least partially therein; and within said housing the device comprises:
an airborne agent detector means operable to detect airborne agents in the air, wherein said means are provided with at least one aperture to the exterior of the device to permit, in use, air from outside of the device to enter said airborne agent detector means;
receiving means for receiving said at least one container of air treatment agent;
emanation means adapted, in use, to emanate the air treatment agent from the device through one or more exit orifices in the housing;
control means in communication with the emanation means and in communication with said airborne agent detector means;
characterised in that said airborne agent detector means is substantially completely isolated from any fluid present in the interior of the housing such that any fluid present in the interior of the housing is substantially completely prevented from passing through said one or more housing walls to be detectable by the airborne agent detector means.
2. A dispensing device according to claim 1, wherein the at least one aperture for the airborne agent detector means is spaced away from the one or more exit orifices.
3. A dispensing device according to claim 1 or claim 2, wherein the at least one aperture is located in a housing wall that is substantially perpendicular with a housing wall of the exit orifice(s).
4. A dispensing device according to claim 1 or claim 2, wherein the at least one aperture is located in a housing wall that is substantially opposite to a housing wall of the exit orifice(s).
5. A dispensing device according to any preceding claim, wherein the housing is provided with a concave recess in a wall thereof that extends into the interior of the housing, said recess being sized to receive the airborne agent detector means therein.
6. A dispensing device according to claim 5, wherein the concave recess is provided with a cover that is sized to fill the recess to and substantially follow the shape and/or contour of the housing wall, and wherein said cover comprises the at least one aperture.

7. A dispensing device according to any preceding claim, wherein the aperture(s) are provided with a filter membrane to prevent or substantially prevent particulate contamination of the airborne agent detector means whilst allowing gas diffusion therethrough.
8. A dispensing device according to any preceding claim, wherein the device is provided with a movable closure means which is configured to close the aperture(s) to the airborne agent detector means to the outside environment shortly before the device emanates an air treatment agent and remain closed for a period after emanation has occurred.
9. A dispensing device according to any preceding claim, wherein the housing is provided with an outwardly extending protrusion adjacent to the aperture(s) communicating with the airborne agent detector means in order to prevent an emanated air treatment agent from entering the aperture(s).
10. A dispensing device according to any preceding claim, wherein the airborne agent detector means comprises at least one odour sensor means.
11. A dispensing device according to claim 10, wherein the odour sensor means comprises one or more metal oxide semiconductor sensors and/or one or more metal oxide sensors.
12. A dispensing device according to claim 10, wherein the at least one odour sensor means is combined with one or more additional sensors from the list of: a motion sensor; a person sensor; a light sensor; a sound sensor; a humidity sensor; a smoke sensor; a temperature sensor.
13. A dispensing device according to claim 11, wherein, in use, energy applied to said metal oxide semiconductor/metal oxide odour sensor(s) is pulsed.
14. A dispensing device according to claim 11, wherein, in use, power is applied to the sensor(s) substantially continuously to get the sensor(s) to an operational temperature, thereafter the power is applied intermittently to the sensor(s) to keep the sensor(s) at an operational temperature.
15. A dispensing device according to claim 11, wherein, in use, power is applied to the sensor(s) substantially continuously to get the sensor(s) to an operational temperature, thereafter

the power is applied intermittently to the sensor(s) to keep the sensor(s) close to an operational temperature.

16. A dispensing device according to claim 11, wherein, in use, power is applied to the sensor(s) substantially continuously to get the sensor(s) to an operational temperature, thereafter followed by a period of no application of power, wherein the non-application of power is followed by the application of power substantially continually to get the sensor(s) to an operational temperature, and the resultant cycle continues thereafter throughout the operation of the device.

17. A dispensing device according to claim 11, wherein, in use, once the metal oxide semiconductor/metal oxide odour sensor has been heated up to an operational temperature the pulses of power may last for a 5 to 1000ms period with an off-period lasting between 0.5 to 10 seconds.

18. A dispensing device according to claim 11, wherein, in use, once the metal oxide semiconductor/metal oxide odour sensor has been heated up to an operational temperature the pulses of power may last for a 5 to 250ms period with an off-period lasting between 0.5 to 7.5 seconds.

19. A dispensing device according to claim 11, wherein, in use, once the metal oxide semiconductor/metal oxide odour sensor has been heated up to an operational temperature the pulses of power may last for a 5 to 100ms period with an off-period lasting between 0.5 to 5.5 seconds.

20. A dispensing device according to claim 11, wherein, in use, once the metal oxide semiconductor/metal oxide odour sensor has been heated up to an operational temperature the pulses of power may last for substantially 35ms with an off-period lasting for substantially 2.2 seconds.

21. A dispensing device according to any preceding claim, wherein, in use, once a quantity of air treatment agent has been emanated the control means prevents the airborne detection means from operating for a period of time.

22. A dispensing device according to claim 20, wherein, in use, the control means is operable to disable the airborne agent detector means from operating for between 1 second to 30 minutes after emanation.

23. A dispensing device according to claim 20, wherein, in use, the control means is operable to disable the airborne agent detector means from operating for substantially between 90 to 180 seconds after emanation.

24. A dispensing device according to any preceding claim, wherein, in use, the at least one airborne agent detector is operable to detect whether the current airborne agent level deviates from a background airborne agent level detected by more than a predetermined amount, wherein the background airborne agent level and the current airborne agent level is calculated by the device.

25. A dispensing device according to claim 24, wherein, in use, the control means are operable to calculate the current airborne agent level by calculating an average of a predetermined number of most recent readings of the airborne agent detector means.

26. A method of improving the sensitivity of a dispensing device with an airborne agent detector mean for at least one air treatment agent, wherein the dispensing device comprises: a housing having one or more walls to define an interior adapted to receive at least one removable container of air treatment agent at least partially therein; and within said housing the device comprises:
an airborne agent detector means operable to detect airborne agents in the air, wherein said means are provided with at least one aperture to the exterior of the device to permit, in use, air from outside of the device to enter said airborne agent detector means;
receiving means for receiving said at least one container of air treatment agent;
emanation means adapted, in use, to emanate the air treatment agent from the device through one or more exit orifices in the housing;
control means in communication with the emanation means and in communication with said airborne agent detector means;
and wherein said airborne agent detector means is substantially completely isolated from any fluid present in the interior of the housing such that any fluid present in the interior of the housing is substantially completely prevented from passing through said one or more housing walls to be detectable by the airborne agent detector means;
and wherein the method comprises the steps of:
loading a container of air treatment agent into said housing and engaging the receiving means;
placing the device in an operational mode wherein the emanation means engage with the container of air treatment agent to cause a quantity of air treatment agent to emanate from the device;

characterised in that any air treatment agent that remains in the device after the emanation thereof is not capable to emanate from within the device to come into contact with the airborne agent detector which is substantially completely isolated therefrom.

27. A dispensing device substantially as described herein with reference to Figures 1 & 2 or Figures 3 to 6 of the drawings.

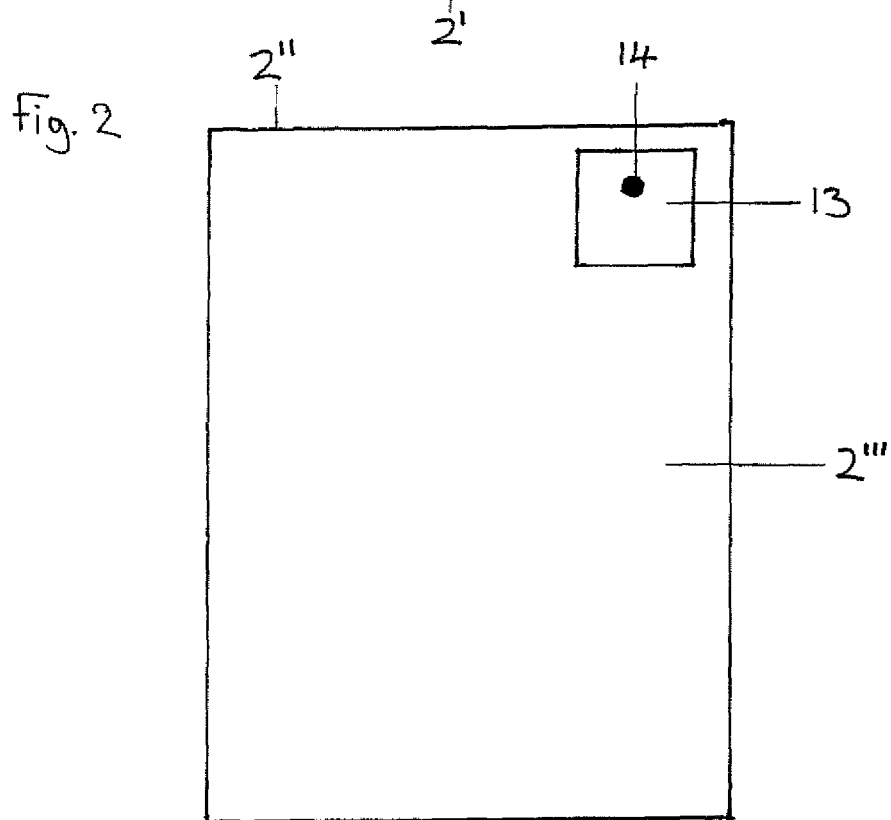
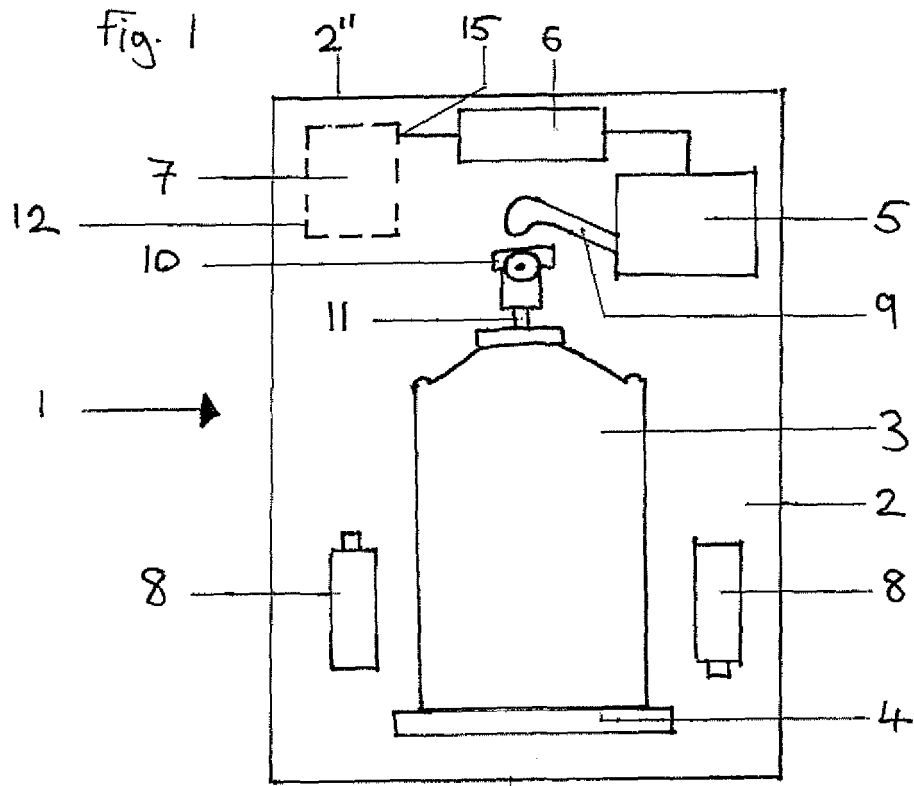

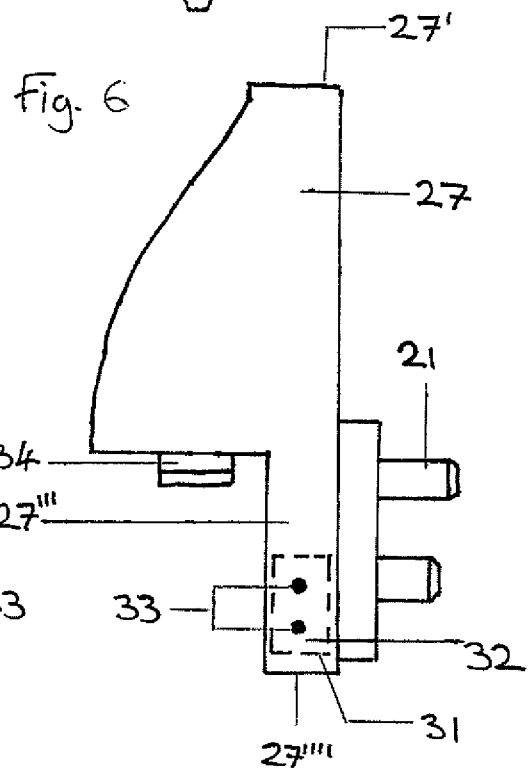
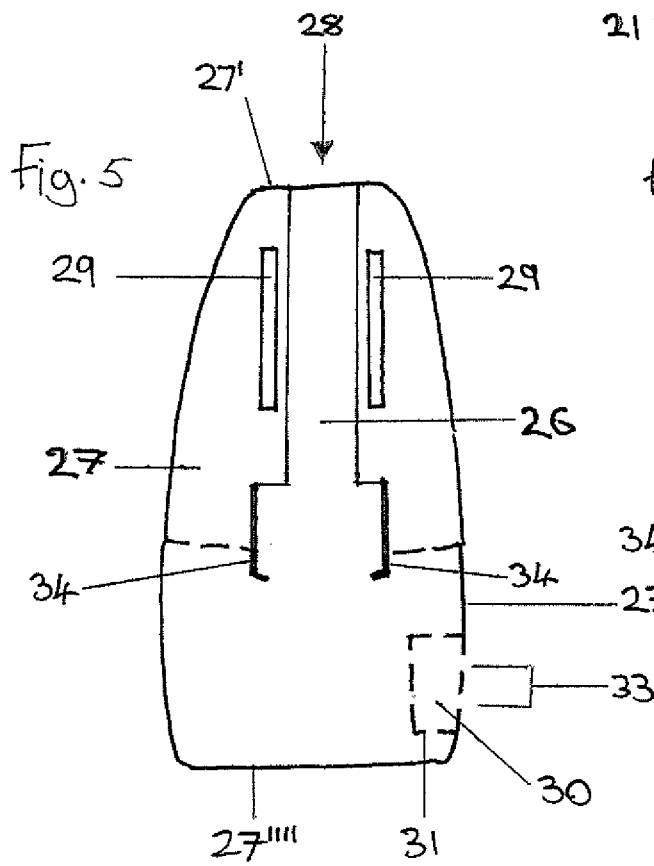
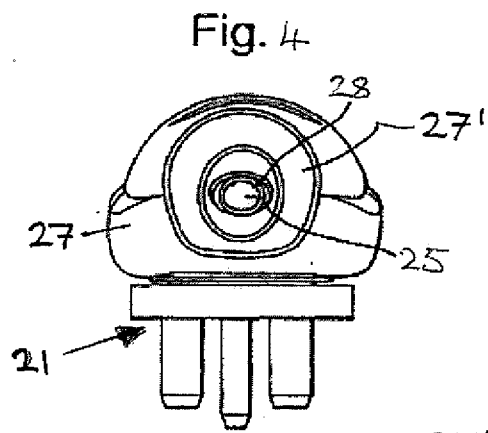
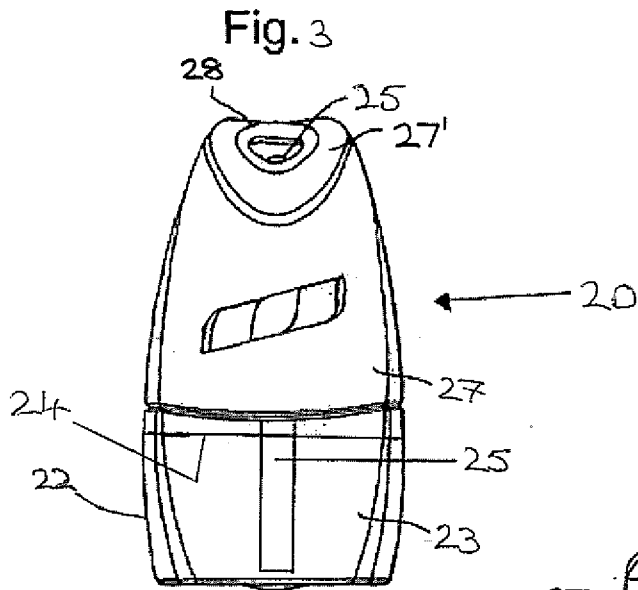

INTERNATIONAL SEARCH REPORT

International application No
PCT/GB2010/051749

A. CLASSIFICATION OF SUBJECT MATTER
INV. A61L9/12
ADD.
According to International Patent Classification (IPC) or to both national classification and IPC

B. FIELDS SEARCHED
Minimum documentation searched (classification system followed by classification symbols)
A61L
Documentation searched other than minimum documentation to the extent that such documents are included in the fields searched

Electronic data base consulted during the international search (name of data base and, where practical, search terms used)
EPO-Internal, WPI Data

C. DOCUMENTS CONSIDERED TO BE RELEVANT

Category*	Citation of document, with indication, where appropriate, of the relevant passages	Relevant to claim No.
X	WO 2009/060212 A2 (RECKITT BENCKISER UK LTD [GB]; BUTLER MARTIN [GB]; JONES CHRIS [US]; L) 14 May 2009 (2009-05-14) page 9, paragraph 8 - page 10, line 3; figure 2 page 9, paragraph 4 page 12, column 1 figure 3	1-4,7-27
X	WO 2008/068486 A2 (RECKITT BENCKISER UK LTD [GB]; BELMONTE ELIAS [GB]; COPEMAN MATTHEW [G] 12 June 2008 (2008-06-12) page 9, line 1; claim 1 page 8, line 6 - page 9 figure 1	1-6
	----- -/--	

Further documents are listed in the continuation of Box C. See patent family annex.

* Special categories of cited documents :

<p>"A" document defining the general state of the art which is not considered to be of particular relevance</p> <p>"E" earlier document but published on or after the international filing date</p> <p>"L" document which may throw doubts on priority claim(s) or which is cited to establish the publication date of another citation or other special reason (as specified)</p> <p>"O" document referring to an oral disclosure, use, exhibition or other means</p> <p>"P" document published prior to the international filing date but later than the priority date claimed</p>	<p>"T" later document published after the international filing date or priority date and not in conflict with the application but cited to understand the principle or theory underlying the invention</p> <p>"X" document of particular relevance; the claimed invention cannot be considered novel or cannot be considered to involve an inventive step when the document is taken alone</p> <p>"Y" document of particular relevance; the claimed invention cannot be considered to involve an inventive step when the document is combined with one or more other such documents, such combination being obvious to a person skilled in the art.</p> <p>"&" document member of the same patent family</p>
--	--

Date of the actual completion of the international search 25 January 2011	Date of mailing of the international search report 03/02/2011
--	--

Name and mailing address of the ISA/ European Patent Office, P.B. 5818 Patentlaan 2 NL - 2280 HV Rijswijk Tel. (+31-70) 340-2040, Fax: (+31-70) 340-3016	Authorized officer Fischer, Michael
--	--

INTERNATIONAL SEARCH REPORT

International application No
PCT/GB2010/051749

C(Continuation). DOCUMENTS CONSIDERED TO BE RELEVANT		
Category*	Citation of document, with indication, where appropriate, of the relevant passages	Relevant to claim No.
X	WO 2009/090415 A2 (RECKITT BENCKISER UK LTD [GB]; BUTLER MARTIN [GB]; JONES CHRIS [US]; L) 23 July 2009 (2009-07-23) page 4, paragraph 2; figure 2 page 8, paragraph 6 -----	1-3, 12-27
X	WO 2006/044416 A2 (JOHNSON & SON INC S C [US]; FURNER PAUL E [US]; GASPER THOMAS P [US];) 27 April 2006 (2006-04-27) odour sensor; paragraph [0060]; figures 1-3 -----	1-3,26, 27
X	JP 2004 141618 A (TOTO LTD) 20 May 2004 (2004-05-20) paragraph [0064]; figure 6 claims 4-6 -----	1-3,26, 27
A	WO 2004/037304 A1 (BEHR GMBH & CO [DE]; GROEMMER CHRISTIAN [DE]; INGELMANN HANS-JOACHIM []) 6 May 2004 (2004-05-06) page 5, lines 28-30 -----	1

INTERNATIONAL SEARCH REPORT

Information on patent family members

International application No

PCT/GB2010/051749

Patent document cited in search report	Publication date	Publication date	Patent family member(s)	Publication date
WO 2009060212	A2	14-05-2009	EP 2227258 A2	15-09-2010

WO 2008068486	A2	12-06-2008	AU 2007330616 A1	12-06-2008
			CA 2670480 A1	12-06-2008
			CN 101541351 A	23-09-2009
			EP 2091575 A2	26-08-2009
			GB 2444636 A	11-06-2008
			JP 2010511460 T	15-04-2010
			KR 20090094260 A	04-09-2009
			US 2010143186 A1	10-06-2010
			ZA 200902900 A	28-07-2010

WO 2009090415	A2	23-07-2009	NONE	

WO 2006044416	A2	27-04-2006	AT 383315 T	15-01-2008
			AT 419197 T	15-01-2009
			AT 417003 T	15-12-2008
			AU 2005295822 A1	27-04-2006
			BR PI0515993 A	19-08-2008
			CA 2583628 A1	27-04-2006
			CA 2683181 A1	27-04-2006
			CN 101065299 A	31-10-2007
			DE 602005004309 T2	17-04-2008
			EP 1807322 A2	18-07-2007
			EP 1832526 A2	12-09-2007
			EP 1832527 A2	12-09-2007
			ES 2296228 T3	16-04-2008
			ES 2319235 T3	05-05-2009
			ES 2317607 T3	16-04-2009
			JP 2008515738 T	15-05-2008
			KR 20070072873 A	06-07-2007
			PT 1807322 E	25-02-2008
			RU 2363634 C2	10-08-2009
			ZA 200703607 A	28-01-2009

JP 2004141618	A	20-05-2004	NONE	

WO 2004037304	A1	06-05-2004	AU 2003277872 A1	13-05-2004
			DE 10249510 A1	06-05-2004
			EP 1558296 A1	03-08-2005
