

(12) STANDARD PATENT
(19) AUSTRALIAN PATENT OFFICE

(11) Application No. **AU 2013328702 B2**

(54) Title
Operating unit

(51) International Patent Classification(s)
H03K 17/96 (2006.01) **H05K 1/03** (2006.01)
G05B 15/02 (2006.01) **H05K 1/16** (2006.01)

(21) Application No: **2013328702** (22) Date of Filing: **2013.10.10**

(87) WIPO No: **WO14/057010**

(30) Priority Data

(31) Number	(32) Date	(33) Country
10 2012 218 647.6	2012.10.12	DE

(43) Publication Date: **2014.04.17**

(44) Accepted Journal Date: **2017.02.16**

(71) Applicant(s)
Schneider Electric Industries SAS

(72) Inventor(s)
Szeflinski, Yoann;Senechault, Emmanuel;KUHNER, Jurgen;LECOANET, Benoit

(74) Agent / Attorney
Watermark Intellectual Property Pty Ltd, L 1 109 Burwood Rd, Hawthorn, VIC, 3122, AU

(56) Related Art
EP 1924000 A2

(12) NACH DEM VERTRAG ÜBER DIE INTERNATIONALE ZUSAMMENARBEIT AUF DEM GEBIET DES PATENTWESENS (PCT) VERÖFFENTLICHTE INTERNATIONALE ANMELDUNG

(19) Weltorganisation für geistiges Eigentum

Internationales Büro

(43) Internationales Veröffentlichungsdatum
17. April 2014 (17.04.2014)



(10) Internationale Veröffentlichungsnummer
WO 2014/057010 A1

- (51) Internationale Patentklassifikation:
H03K 17/96 (2006.01) *H05K 1/03* (2006.01)
G05B 15/02 (2006.01) *H05K 1/16* (2006.01)
- (21) Internationales Aktenzeichen: PCT/EP2013/071107
- (22) Internationales Anmeldedatum:
10. Oktober 2013 (10.10.2013)
- (25) Einreichungssprache: Deutsch
- (26) Veröffentlichungssprache: Deutsch
- (30) Angaben zur Priorität:
10 2012 218 647.6
12. Oktober 2012 (12.10.2012) DE
- (71) Anmelder: SCHNEIDER ELECTRIC INDUSTRIES SAS [FR/FR]; 35 rue Joseph Monier - CS30323, F-92500 Rueil-Malmaison (FR).
- (72) Erfinder: SZEFLINSKI, Yoann; 50 rue de la Marelle, F-38500 La Buisse (FR). SENECHAULT, Emmanuel; 1 rue Louis Vidal, F-38100 Grenoble (FR).
- (74) Anwalt: MANITZ FINSTERWALD UND PARTNER GBR; Postfach 31 02 20, 80102 München (DE).
- (81) Bestimmungsstaaten (soweit nicht anders angegeben, für jede verfügbare nationale Schutzrechtsart): AE, AG, AL, AM, AO, AT, AU, AZ, BA, BB, BG, BH, BN, BR, BW, BY, BZ, CA, CH, CL, CN, CO, CR, CU, CZ, DE, DK, DM, DO, DZ, EC, EE, EG, ES, FI, GB, GD, GE, GH, GM, GT, HN, HR, HU, ID, IL, IN, IR, IS, JP, KE, KG, KN, KP, KR, KZ, LA, LC, LK, LR, LS, LT, LU, LY, MA, MD, ME, MG, MK, MN, MW, MX, MY, MZ, NA, NG, NI, NO, NZ, OM, PA, PE, PG, PH, PL, PT, QA, RO, RS, RU, RW, SA, SC, SD, SE, SG, SK, SL, SM, ST, SV, SY, TH, TJ, TM, TN, TR, TT, TZ, UA, UG, US, UZ, VC, VN, ZA, ZM, ZW.
- (84) Bestimmungsstaaten (soweit nicht anders angegeben, für jede verfügbare regionale Schutzrechtsart): ARIPO (BW,

[Fortsetzung auf der nächsten Seite]

(54) Title: OPERATING UNIT

(54) Bezeichnung : BEDIENEINHEIT

Fig.4

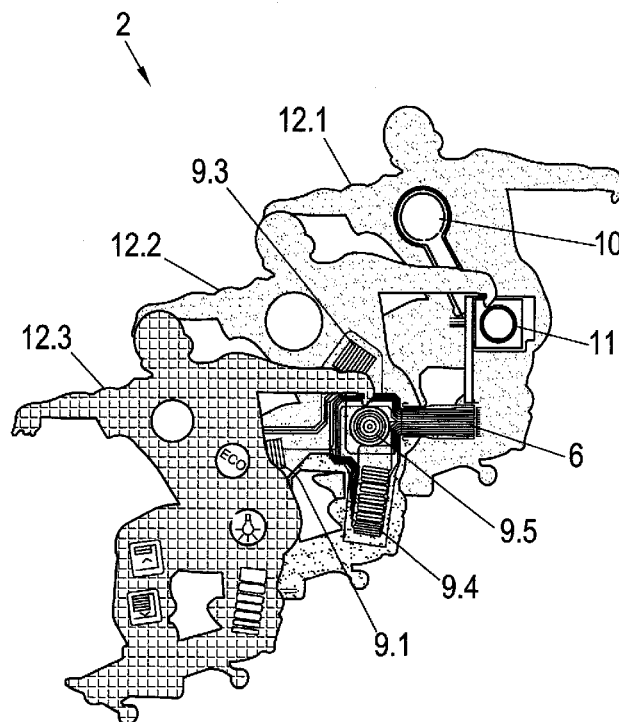

(57) Abstract: The invention relates to an operating unit of an installation device, said device comprising a communication insert for controlling electrical consumers. The operating unit has functional elements and said unit is connected by wire and/or wirelessly to the communication insert for unidirectional or bidirectional signal transmission and/or for supplying voltage. The functional elements comprise printed electronic components which are mechanically flexible and are situated on a mechanically flexible carrier foil.

(57) Zusammenfassung: Die Erfindung betrifft eine Bedieneinheit eines Installationsgerätes, wobei das Installationsgerät einen Kommunikationseinsatz zur Ansteuerung von elektrischen Verbrauchern umfasst, wobei die Bedieneinheit Funktionselemente aufweist, und wobei die Bedieneinheit drahtgebunden und/oder drahtlos mit dem Kommunikationseinsatz zur uni- oder bidirektionalen Signalübertragung und/oder zur Spannungsversorgung verbunden ist. Die Funktionselemente umfassen gedruckte elektronische Bauteile, die mechanisch flexibel ausgebildet sind, und auf einer mechanisch flexiblen Trägerfolie angeordnet sind.

WO 2014/057010 A1



GH, GM, KE, LR, LS, MW, MZ, NA, RW, SD, SL, SZ, TZ, UG, ZM, ZW), eurasisches (AM, AZ, BY, KG, KZ, RU, TJ, TM), europäisches (AL, AT, BE, BG, CH, CY, CZ, DE, DK, EE, ES, FI, FR, GB, GR, HR, HU, IE, IS, IT, LT, LU, LV, MC, MK, MT, NL, NO, PL, PT, RO, RS, SE, SI, SK, SM, TR), OAPI (BF, BJ, CF, CG, CI, CM, GA, GN, GQ, GW, KM, ML, MR, NE, SN, TD, TG).

Veröffentlicht:

- mit internationalem Recherchenbericht (Artikel 21 Absatz 3)
- vor Ablauf der für Änderungen der Ansprüche geltenden Frist; Veröffentlichung wird wiederholt, falls Änderungen eingehen (Regel 48 Absatz 2 Buchstabe h)

Title: Operating unit

Description

5 The invention relates to an operating unit.

10 Operating units for electrical installation devices for controlling circuit elements or communication inserts are known in the most varied forms, for example for building services engineering, for industrial devices and machines or also for switch cabinets. The operating units are typically a component of the installation device, with either a single compact device unit or a module device design being implemented. It is furthermore known to arrange operating units separately from the circuit elements or communication inserts to be controlled, wherein the technical signal communication and/or the electrical supply takes place via a
15 wired connection or via a wireless connection. Such operating units comprise different functional elements with which the most varied display functions and/or operating functions can be implemented.

20 The operating units are fixed with respect to their physical configuration (shape, color, design) and the arrangement of individual functional elements in the extent of the respective product spectrum. Furthermore, an integration of the operating unit into the installation device results in a binding to the installation location of the installation device. The design and the arrangement of operating units is largely non-flexible due to this system.

25 Printed electronic components, so-called printed electronics, are known from semiconductor engineering which are mechanically flexible and of flat construction. The manufacture of these printed electronic components takes place with the aid of normal printing processes. Functional materials are used
30 instead of graphic printing ink as the printing material for printing electronics. As in conventional electronics manufacture, conductive, semi-conductive, dielectric and/or insulating materials as well as active materials, e.g. for printed batteries, are

used. A printed electronic component typically comprises a plurality of layers of functional materials which are printed over one another.

5 Any discussion of documents, devices, acts or knowledge in this specification is included to explain the context of the invention. It should not be taken as an admission that any of the material formed part of the prior art base or the common general knowledge in the relevant art on or before the priority date of the claims herein.

10 Comprises/comprising and grammatical variations thereof when used in this specification are to be taken to specify the presence of stated features, integers, steps or components or groups thereof, but do not preclude the presence or addition of one or more other features, integers, steps, components or groups thereof.

15 It would be desirable to provide an operating unit with which customized and/or application-specific embodiments can be simply implemented.

20 In accordance with the present invention, there is provided an operating unit of an installation device, in particular of building services engineering, wherein the installation device comprises a communication insert for controlling electrical consumers; wherein the operating unit has functional elements; wherein the operating unit is connected in a wired and/or wireless manner to the communication insert for a unidirectional or bidirectional signal transfer and/or for
25 the voltage supply, and wherein the functional elements comprise printed electronic components which are mechanically flexible and which are arranged on a mechanically flexible carrier film.

30 The present invention has the advantage that large freedoms are provided for the design of an operating unit with respect to its physical embodiment and to the arrangement of functional elements. Customized and application-specific solutions can easily be implemented.

Printed electronic components allow a simple and inexpensive implementation in a production-orientated aspect of different embodiments of operating units. A combination of functional elements on the basis of printed electronic components with non-printed electrical/electronic construction elements as well as with
5 mechanical construction elements is furthermore possible in this respect.

The operating unit can be configured largely freely depending on the functions. Application-specific and/or customized demands can be composed directly by the manufacturer, architect, fitter or end user through corresponding planning means,
10 for example electronic or computer-

CONTINUES ON PAGE 3

assisted configuration programs, with a large variability with respect to shape, color and material as well as to the positioning of functional elements.

- 5 The operating unit in accordance with the invention can be used in a room-designing manner, with independent design embodiments being able to be included in the room design as integrating embodiments, for example by representational and/or color designs. A matching to a changing room design can advantageously easily be implemented by the
- 10 use of a correspondingly newly designed operating unit while maintaining existing functions. A room operation can thus be renewed and replaced simply and inexpensively as required.

The printed electronic components are mechanically flexible and of flat

15 construction and can be manufactured with the aid of different printing processes. A number of components can be produced in a short time using inline printing processes. To reduce production costs, cost-efficient printing techniques such as screen printing, rotogravure, flexo printing and offset printing as well as digital printing processes can be used. Products

20 manufactured in the ink jet printing process, allow different degrees of freedom with respect to design and layer thickness. Once the correct design has been found, the results can e.g. be transferred to screen printing processes; this allows larger layer thicknesses and thus very high performance of the printed material.

25

A printed electronic component comprises a plurality of layers of functional materials which are printed over one another. Conductive, semiconductive, dielectric and/or insulating materials as well as active materials can be used as print material for printing the printed electronic components. They

30 can be either organic or inorganic materials. The functional materials have to be processed into print inks or print pastes to allow them to be applied

by means of printing processes. In addition to the viscosity, factors such as adhesion and compatibility with the layer below play a large role in this respect to achieve an ideal function.

- 5 Due to the simple manufacturing process which is rich in variants with respect to material and color composition, customized and user-specific solutions from small production runs up to individual solutions can be produced in an excellent manner.
- 10 The operating unit in accordance with the invention is suitable for installation devices of building services engineering, with the installation device being able to be fastened to the building side and comprising a communication insert for controlling electric consumers. The operating unit can be releasably or non-releasably connected to the installation device.
- 15 In another embodiment, the operating unit is arranged physically separate from the installation device at the building side. Further areas of application are industrial devices and machines or also switch cabinets.

The operating unit has a multilayer film structure in which functional
20 elements can be integrated which are connected to the communication insert for technical signal communication and/or for electrical supply. In accordance with the invention, the functional elements can be designed as printed electronic components which are mechanically flexible.

- 25 The operating unit comprises, individually or in combination, functional elements which have electrical, optical or mechanical functions, for example as input elements and/or as output elements. Functional elements can be printed electronic components, for example in a capacitive, inductive, resistive, thermal, optical or photovoltaic design,
30 lighting elements, e.g. OLEDs, energy stores, data stores and/or processors, as well as non-printed electronic construction elements, e.g.

RFID elements, stores, batteries, LEDs, displays and/or mechanical components.

5 The functional elements of the operating unit typically require an electrical energy supply. In an embodiment, the electrical energy can be supplied from the installation device or from the communication insert, with wired or wireless transfer processing being possible. Electromagnetic or inductive transfer processes are suitable for a wireless energy transfer.

10 In a further embodiment, an independent energy supply takes place, for example, by replaceable or self-charging energy stores. Micro fuel cells, which can be realized in a largely freely definable format, from a button cell to film structures, are advantageously suitable for this purpose. An energy store which recharges itself is an advantageous solution for
15 applications where small construction sizes and very long running times are important. This can be achieved by a combination of a miniaturized energy store and a so-called micro energy harvesting (MEH) generator which is able to acquire electrical energy from the environment, e.g. light irradiation.

20 In a further embodiment, an independent energy supply takes place, for example by actuation-dependent generation of energy, e.g. by means of piezoelectric or mechanical effects. These embodiments allow a space-saving and long-life energy supply. The operating unit can be operated
25 autonomously and thus in a mobile manner and remote from the installation location at freely selectable use locations, for example in a meeting room or in a lecture hall, by an independent energy supply.

30 An illumination of the operating unit or the output of light signals by the operating unit can be fed by illumination sources of the communication insert in that light is conducted through optical conductors to the

corresponding lighting elements. Alternatively, autonomous illumination sources can also be used in the operating unit which gain the required electrical or optical energy from the environment of the operating unit, e.g. by electroluminescence or by photovoltaic effects.

5

The operating unit has a multilayer film structure into which different functional elements can be integrated. The functional elements in the form of printed electronic components are mechanically flexible and can be arranged on a flexible carrier film, preferably by a printing process, after or

10 during their manufacture. A plurality of such carrier films with printed electronic components can be arranged within the film structure. Each carrier film has at least one film at at least one side, advantageously at both sides, the film comprising a flexible, preferably thin substrate.

Functional elements in the form of non-printed electronic construction

15 elements and/or mechanical components can also be arranged on each film, including the carrier film. The positioning of the functional elements on the respective films is largely freely selectable within the framework of the configuration.

20 The film of the film structure at the building side can preferably be used for the reception of non-printed electronic components and for decoupling from electrical conductors. The user-side film can serve as a protective layer for the operating unit, including all the functional elements.

Furthermore, decorative elements and operating elements or operating

25 panels can be integrated. Intuitive operating fields are advantageous which can be realized by large-area regions as well as by tactile and/or haptic surfaces. The user-side film can advantageously be cleaned easily by using suitable materials or has dirt-repelling or self-cleaning properties.

The color and area design of all films is freely selectable. The film

30 structure made up in total of a plurality of layers can form a self-supporting structure of the operating unit and is thus mechanically flexible overall. In a

further embodiment, the operating unit can be integrated in a stable frame or in a housing structure, for example in the form of a so-called panel.

5 The operating unit can be fastened to a carrier element at the building side, preferably to a building wall or to a piece of furniture, wherein different types of fastening are possible, for example by means of adhesive, magnetic or electrostatic adhesion or mechanical fastening techniques. The type of fastening can be matched to the properties of the carrier element, in particular to the material property and/or to the surface
10 property. An intermediate layer is preferably formed at the rear side to be able to compensate irregularities at the carrier element, e.g. at the plaster or at wallpaper. A releasable/reversible fastening technique can advantageously also be realized to allow changing operating locations.

15 The functional elements of the operating unit are connected via electrical lines to a coupling point which can be connected to a coupling point at the communication insert in a wired or wireless manner for transferring signals or electrical energy. A wired connection can take place via a flexible PCB and a plug-in connection. The wireless connection in particular allows a
20 large freedom with respect to the arrangement of the operating unit.

The communication between the communication insert and the electrical consumers can take place in a wired and/or wireless manner. The consumers can be connected directly or indirectly. On the one hand,
25 starting from the operating element, load-switching actions can be triggered directly by the communication insert. In another embodiment, a signal transfer to load-switching actuators which then control the electrical consumers as an intermediate member can follow via the communication insert. Different communication programs serve for this, for example, bus-
30 assisted systems such as LON, KNX or Zigbee.

The above-described design allows individual customized operating units with respect to the design aspect and with respect to the function and positioning of functional elements on a film/film structure.

- 5 Further details, features and advantages of the invention result from the following description of a preferred embodiment with reference to the drawings.

There are shown:

10

Figure 1 a schematic representation of an arrangement of an installation device in an exploded view;

Figure 2 a front view of the operating unit in accordance with Figure 1,

15

Figure 3 a front view of a further operating unit;

Figure 4 an exploded view of a further operating unit;

- 20 Figure 5 a schematic representation of a further arrangement of an installation device in an exploded view; and

Figure 6 a from view of the operating unit in accordance with Figure 6.

- 25 Components which are the same or which have the same effect are provided with the same reference numerals in the following description.

An installation device 1 is shown schematically in Figure 1 which is an installation device of building services engineering in the embodiment
30 shown, having an operating unit 2 at the front side, wherein the different units are shown in an exploded view. The installation device 1 is fastened

in an installation socket 4 arranged in a building wall 3. The installation device 1 has a communication insert 5 which serves for the control of electrical consumers, not shown. The operating unit 2 has different functional elements 9-11 which are connected to the communication insert 5 in a wired manner to allow an electrical supply and a technical signal supply. For this purpose, the functional elements in the operating unit 2 are connected via a flexible conductor structure 6 to a coupling point 7 in the form of a plug-in connection. A coupling point 8 in the form of a complementary plug-n connection at the communication insert 5 completes the electrical connection. In an assembled position of all units, the operating unit 2 covers the installation socket 4 and the communication insert 5 and is arranged in a surface-flush manner to the building wall 3, wherein the coupling points 7 and 8 are completely located in the installation socket 4. In accordance with an embodiment, not shown, the plug-in connection can also serve, by corresponding housing bodies, for the mechanically releasable or non-releasable connection between the operating unit 2 and the installation device 1.

The communication between the communication insert 5 and the electrical consumers is not shown in any more detail here, but can take place in a wired and/or wireless manner. The consumers can be connected directly or indirectly. On the one hand, starting from the operating element 2, electrical consumers can be directly connected by the communication insert 5. In another embodiment, a signal transfer to load-switching actuators which then control the electrical consumers as an intermediate member can follow via the communication insert 5. Different communication programs serve for this, for example, bus-assisted systems such as LON, KNX or Zigbee.

In accordance with Figure 2, the operating unit 2 comprises different functional elements 9-11, which are each surrounded in a circular manner

and which produce, combined in an areal manner, an operating surface in the form of a film 12.3. Printed electronic components 9 are designed in the form of capacitive sensors as switches or push-buttons 9-1 and 9.2 for upward and downward movements of blinds and as switches or push-
5 buttons 9.3 for an energy-saving function. A display 10 having a temperature display as well as an annular lighting element 11 for illumination purposes is furthermore arranged. The lighting element 11 is fed via light sources, not shown, in the communication insert 5, wherein the light source and the lighting element 11 are aligned with respect to one
10 another and are preferably fixed with respect to one another in the final assembly position to be able to transfer light. Alternatively, the lighting element 11 can also be controlled by signals transmitted electrically to the operating unit 2. The functional elements 9-11 can only be identified with reference to the visible operating fields in this representation.

15

A further embodiment of an operating unit 2 is shown by way of example in a front view in Figure 3. The operating unit 2 is cruciform. Printed electronic components 9 are configured in the form of capacitive sensors as switches or push-buttons 9.1 and 9.2 for upward and downward
20 movements of blinds, as switches or push-buttons 9.3 for an energy saving function and arranged in a sequence of a plurality of capacitive sensors as slide buttons 9-4 for a dimmable lighting. A brightness display 10.1 for the degree of dimming of the lighting is furthermore arranged as a feedback. The functional elements 9-11 can only be identified with
25 reference to the visible operating fields in this representation.

The basic design of an operating unit 2 is shown in more detail in Figure 4. The operating unit 2 is in this respect implemented as an areal image of a person. Printed electronic components 9 are configured in the form of
30 capacitive sensors as switches or push-buttons 9.1 and 9.2 for upward and downward movements of blinds, as switches or push-buttons 9.3 for

an energy saving function and arranged in a sequence of a plurality of capacitive sensors as slide buttons 9-4 for a dimmable lighting. An operating field lighting 9.5 is furthermore present.

- 5 The operating unit 2 comprises a film structure which is built up of a plurality of layers 12 overall and which is mechanically flexible per se. A film 12.1 at the building side has a display 10 and an annular brightness display 11 which comprises a plurality of LEDs and which reproduces the degree of dimming of the lighting. Furthermore, the film 12.1 is equipped at
- 10 the rear side with an adhesive material to fasten the complete film structure to a building wall 3, for example. A middle carrier film 12.2 has the printed electronic components 9.1, 9.2, 9.3 and 9.4 which are preferably arranged on this flexible carrier film 12.2 by a printing method during their manufacture. The printed electronic components 9.1, 9.2, 9.3
- 15 and 9.4 comprise a plurality of layers of functional materials printed over one another and are designed as capacitive sensors. Connectors of the functional elements 9-11 are combined centrally on the carrier film 12.2 and are connected via a flexible conductor structure 6 to the coupling point 7 not shown here. A user-side film 12.3 serves, on the one hand, as a
- 20 protective film for the operating unit 2 itself and, on the other hand, for the functional elements 9-11 arranged on the films below. Furthermore, operating fields for the functional elements 9.-11 arranged on the films lying below are located on the film 12.3.
- 25 The operating unit 2 in accordance with the invention can become a component of the decoration or can be largely (invisibly) integrated. The operating unit 2 can be manufactured in a completely customized manner, for example directly by the customer by corresponding electronic configuration programs with great variability with respect to shape,
- 30 background (design, color) and to the combination of functions.

A further embodiment of the operating unit 2 is shown in Figures 5 and 6, with the operating unit 2 being arranged at a building wall 3 remote from the other installation device 1. Printed electronic components 9 are each designed in a sequence of a plurality of capacitive sensors as sliding
5 buttons 9.3 for different electrical consumers (lighting 13.1, blinds 13.2, presentation area 13.3). A state display 10.1, 10.2 and 10.3 for the degree of actuation of the consumer is furthermore arranged as feedback in each case.

10 The functional elements 9-11 of the operating unit 2 are connected to a coupling point 7, not shown, which is connected wirelessly to a coupling point 8 at the communication insert 5 for the transfer of signals. The electrical supply takes place via energy stores, not shown, arranged in the operating unit 2. The control of the electrical consumers 13.1, 13.2 and
15 13.3 takes place via a bus-assisted communication system. The wireless connection allows a large freedom with respect to the arrangement of the operating unit 2. The operating unit 2 can then be operated autonomously and in a mobile manner and remote from the installation location at freely selectable use locations, for example in a meeting room or in a lecture
20 hall.

The above description of the embodiment serves only for illustrative purposes and not for the purpose of restricting the invention. Various changes and modifications are possible within the framework of the
25 invention without going beyond the extent of the invention or its equivalents.

Reference numeral list

	1	installation device
	2	operating unit
5	3	building wall
	4	installation socket
	5	communication insert
	6	conductor structure
	7	coupling point
10	8	coupling point
	9	printed electronic component
	10	display, indication
	11	lighting element
	12	film
15	13	electrical consumer

CLAIMS:

1. An operating unit of an installation device, in particular of building services engineering,
 - wherein the installation device comprises a communication insert for controlling electrical consumers;
 - wherein the operating unit has functional elements;
 - wherein the operating unit is connected in a wired and/or wireless manner to the communication insert for a unidirectional or bidirectional signal transfer and/or for the voltage supply, and
 - wherein the functional elements comprise printed electronic components which are mechanically flexible and which are arranged on a mechanically flexible carrier film.
2. An operating unit in accordance with claim 1, wherein the printed electronic components comprise sensors, displays, lighting elements, energy stores, data stores and/or processors.
3. An operating unit in accordance with any one of the preceding claims, wherein the carrier film with the functional elements has at least one film at at least one side.
4. An operating unit in accordance with any one of the preceding claims, wherein the film comprises a flexible substrate.
5. An operating unit in accordance with any one of the preceding claims, wherein the operating unit comprises mechanical construction elements and/or non-printed electrical construction elements.

6. An operating unit in accordance with any one of the preceding claims, wherein the functional elements at the operating unit are connected to a first coupling point which can be connected electronically in a wired or wireless manner to a second coupling part at the communication insert.
7. An operating unit in accordance with any one of the preceding claims, wherein the functional elements are electrically supplied by the communication insert, independently and/or by user-side actuation.
8. An operating unit in accordance with any one of the preceding claims, wherein lighting elements of the operating unit are fed by illumination sources of the communication insert and/or by independent illumination sources.
9. An operating unit in accordance with any one of the preceding claims, wherein signals can be transferred in a wired and/or wireless manner between the communication insert and the electrical consumers.
10. An operating unit in accordance with any one of the preceding claims, wherein the operating unit is fastened to a carrier element.
11. An operating unit in accordance with any one of the preceding claims, wherein the operating unit and the installation device are not physically connected.
12. An operating unit in accordance with any one of the preceding claims, wherein the arrangement and/or configuration of the functional elements and/or of the films can be planned using a planning means in accordance with individual and/or application-specific presettings and can be used as parameters for the manufacture of the operating unit.
13. An operating unit in accordance with any one of the preceding claims, wherein the areal positioning of the functional elements between the films can be individually configured.

14. An operating unit in accordance with any one of the preceding claims, wherein the shape, the material, the surface and/or the design of the films can be individually configured.

SCHNEIDER ELECTRIC INDUSTRIES SAS

WATERMARK INTELLECTUAL PROPERTY PTY LTD

P40350AU00

Fig.1

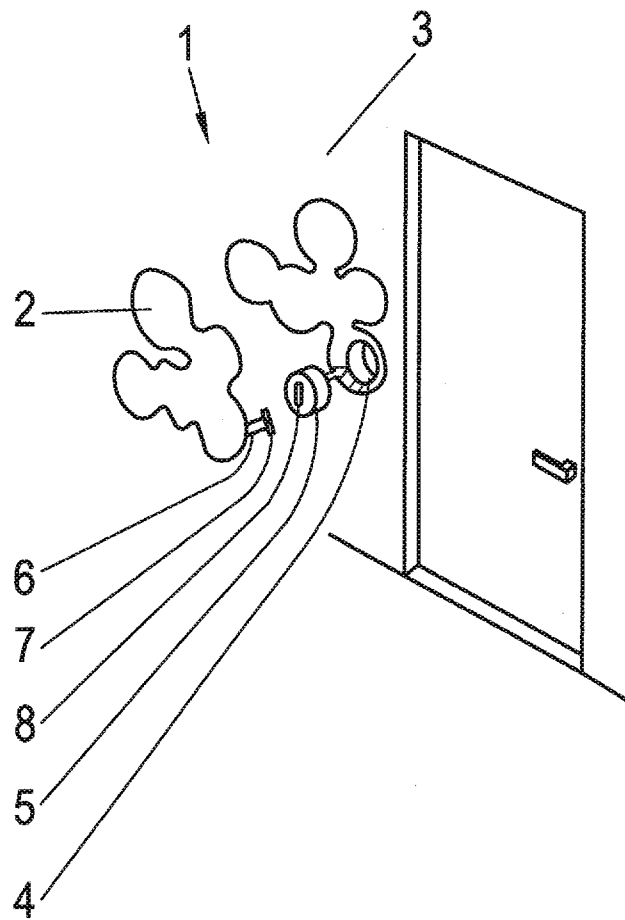

Fig.2

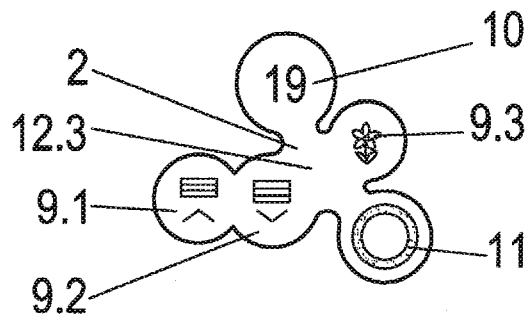

Fig.3

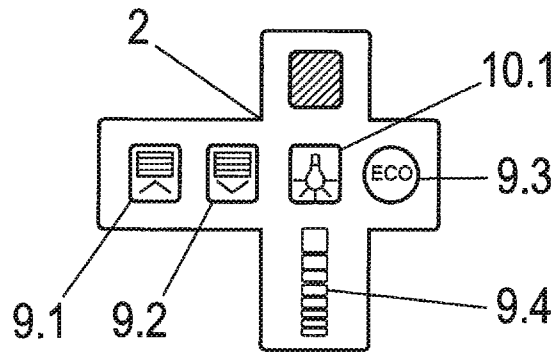

Fig.5

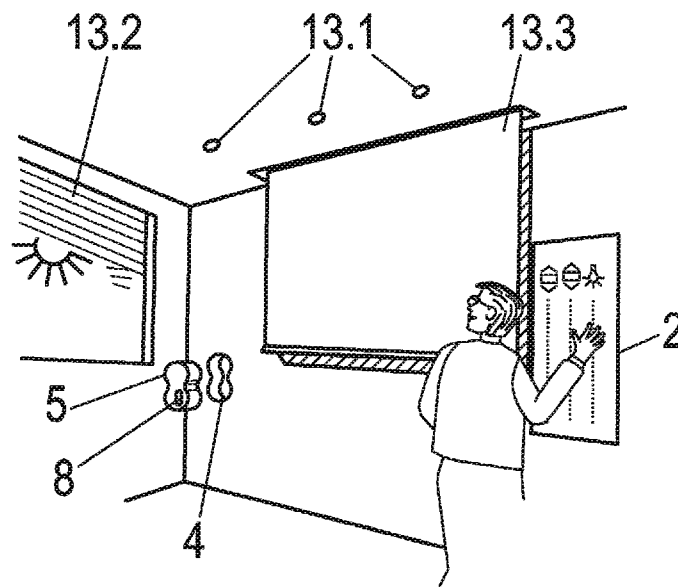

Fig.6

