



- (51) International Patent Classification:
B29C 67/00 (2006.01)
- (21) International Application Number:
PCT/US2016/016304
- (22) International Filing Date:
3 February 2016 (03.02.2016)
- (25) Filing Language: English
- (26) Publication Language: English
- (30) Priority Data:
62/112,283 5 February 2015 (05.02.2015) US
- (71) Applicant: CARBON3D, INC. [US/US]; 312 Chestnut St., Redwood City, California 94063 (US).
- (72) Inventors: ERMOSHKIN, Alexander; 440 Robin Road, Chapel Hill, North Carolina 27516 (US). SHIRVAN-YANTS, David; 427 Summerwalk Circle, Chapel Hill, North Carolina 27517 (US). TUMBLESTON, John R.; 1095 Santa Cruz Ave. #3, Menlo Park, California 94025 (US).
- (74) Agent: SIBLEY, Kenneth D.; Myers Bigel Sibley & Sajovec, P.A., P.O. Box 37428, Raleigh, North Carolina 27627 (US).

- (81) Designated States (unless otherwise indicated, for every kind of national protection available): AE, AG, AL, AM, AO, AT, AU, AZ, BA, BB, BG, BH, BN, BR, BW, BY, BZ, CA, CH, CL, CN, CO, CR, CU, CZ, DE, DK, DM, DO, DZ, EC, EE, EG, ES, FI, GB, GD, GE, GH, GM, GT, HN, HR, HU, ID, IL, IN, IR, IS, JP, KE, KG, KN, KP, KR, KZ, LA, LC, LK, LR, LS, LU, LY, MA, MD, ME, MG, MK, MN, MW, MX, MY, MZ, NA, NG, NI, NO, NZ, OM, PA, PE, PG, PH, PL, PT, QA, RO, RS, RU, RW, SA, SC, SD, SE, SG, SK, SL, SM, ST, SV, SY, TH, TJ, TM, TN, TR, TT, TZ, UA, UG, US, UZ, VC, VN, ZA, ZM, ZW.
- (84) Designated States (unless otherwise indicated, for every kind of regional protection available): ARIPO (BW, GH, GM, KE, LR, LS, MW, MZ, NA, RW, SD, SL, ST, SZ, TZ, UG, ZM, ZW), Eurasian (AM, AZ, BY, KG, KZ, RU, TJ, TM), European (AL, AT, BE, BG, CH, CY, CZ, DE, DK, EE, ES, FI, FR, GB, GR, HR, HU, IE, IS, IT, LT, LU, LV, MC, MK, MT, NL, NO, PL, PT, RO, RS, SE, SI, SK, SM, TR), OAPI (BF, BJ, CF, CG, CI, CM, GA, GN, GQ, GW, KM, ML, MR, NE, SN, TD, TG).

Published: — with international search report (Art. 21(3))

(54) Title: METHOD OF ADDITIVE MANUFACTURING BY FABRICATION THROUGH MULTIPLE ZONES

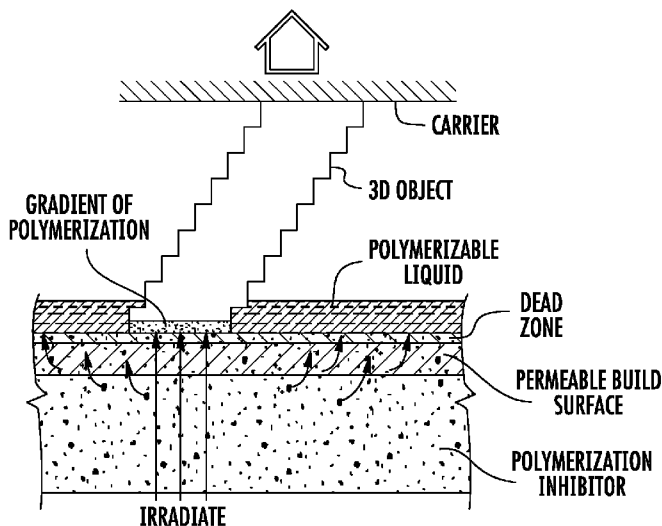

FIG. 1

(57) Abstract: A method of forming a three-dimensional object is carried out by: (a) providing a carrier and an optically transparent member having a build surface, the carrier and the build surface defining a build region therebetween, with the carrier positioned adjacent and spaced apart from the build surface at a start position; then (b) forming an adhesion segment of the three-dimensional object (c) optionally but preferably forming a transition segment of the three dimensional object; and then (d) forming a body segment of the three dimensional object. In each case, the segment can be formed by: (i) filling the build region with a polymerizable liquid, (ii) continuously or intermittently irradiating the build region with light through the optically transparent, and (iii) continuously or intermittently advancing the carrier away from the build surface, to thereby form that segment from the polymerizable liquid.



METHOD OF ADDITIVE MANUFACTURING BY FABRICATION THROUGH MULTIPLE ZONES

5 Alexander Ermoshkin, David Shirvanyants, and John R. Tumbleston

Related Applications

This application claims the benefit of United States Provisional Application No. 62/112,283, filed February 5, 2015, the disclosure of which is incorporated by reference
10 herein in its entirety.

Field of the Invention

The present invention concerns methods and apparatus for the fabrication of solid
three-dimensional objects from liquid materials.

15

Background of the Invention

In conventional additive or three-dimensional fabrication techniques, construction of a
three-dimensional object is performed in a step-wise or layer-by-layer manner. In particular,
layer formation is performed through solidification of photo curable resin under the action of
20 visible or UV light irradiation. Two techniques are known: one in which new layers are
formed at the top surface of the growing object; the other in which new layers are formed at
the bottom surface of the growing object.

If new layers are formed at the top surface of the growing object, then after each
irradiation step the object under construction is lowered into the resin "pool," a new layer of
25 resin is coated on top, and a new irradiation step takes place. An early example of such a
technique is given in Hull, US Patent No. 5,236,637, at Figure 3. A disadvantage of such "top
down" techniques is the need to submerge the growing object in a (potentially deep) pool of
liquid resin and reconstitute a precise overlayer of liquid resin.

If new layers are formed at the bottom of the growing object, then after each
30 irradiation step the object under construction must be separated from the bottom plate in the
fabrication well. An early example of such a technique is given in Hull, US Patent No.
5,236,637, at Figure 4. While such "bottom up" techniques hold the potential to eliminate the
need for a deep well in which the object is submerged by instead lifting the object out of a

relatively shallow well or pool, a problem with such “bottom up” fabrication techniques, as commercially implemented, is that extreme care must be taken, and additional mechanical elements employed, when separating the solidified layer from the bottom plate due to physical and chemical interactions therebetween. For example, in US Patent No. 7,438,846, an elastic separation layer is used to achieve “non-destructive” separation of solidified material at the bottom construction plane. Other approaches, such as the B9Creator™ 3-dimensional printer marketed by B9Creations of Deadwood, South Dakota, USA, employ a sliding build plate. *See, e.g.*, M. Joyce, US Patent App. 2013/0292862 and Y. Chen et al., US Patent App. 2013/0295212 (both Nov. 7, 2013); *see also* Y. Pan et al., *J. Manufacturing Sci. and Eng.* **134**, 051011-1 (Oct. 2012). Such approaches introduce a mechanical step that may complicate the apparatus, slow the method, and/or potentially distort the end product.

Continuous processes for producing a three-dimensional object are suggested at some length with respect to “top down” techniques in US Patent No. 7,892,474, but this reference does not explain how they may be implemented in “bottom up” systems in a manner non-destructive to the article being produced. Accordingly, there is a need for alternate methods and apparatus for three-dimensional fabrication that can obviate the need for mechanical separation steps in “bottom-up” fabrication.

Summary of the Invention

Described herein are methods, systems and apparatus (including associated control methods, systems and apparatus), for the production of a three-dimensional object by additive manufacturing. In preferred (but not necessarily limiting) embodiments, the method is carried out continuously. In preferred (but not necessarily limiting) embodiments, the three-dimensional object is produced from a liquid interface. Hence they are sometimes referred to, for convenience and not for purposes of limitation, as “continuous liquid interphase printing” or “continuous liquid interface production” (“CLIP”) herein (the two being used interchangeably). *See, e.g.*, J. Tumbleston et al., *Continuous liquid interface production of 3D objects*, *Science* **347**, 1349-1352 (published online March 16, 2015). A schematic representation is given in **Figure 1** herein.

The present invention provides a method of forming a three-dimensional object, comprising:

providing a carrier and an optically transparent member having a build surface, said carrier and said build surface defining a build region therebetween;

filling said build region with a polymerizable liquid,
continuously or intermittently irradiating said build region with light through said
optically transparent member to form a solid polymer from said polymerizable liquid, and
continuously or intermittently advancing (*e.g.*, sequentially or concurrently with said
5 irradiating step) said carrier away from said build surface to form said three-dimensional
object from said solid polymer.

In some embodiments, illumination is carried out sequentially, and preferably at
higher intensity (*e.g.*, in “strobe” mode), as described further below.

In some embodiments, fabrication is carried out in two or three sequential patterns,
10 from a base zone, through an optional transition zone, to a body zone, as described further
below.

In some embodiments, the carrier is vertically reciprocated with respect to the build
surface, to enhance or speed the refilling of the build region with the polymerizable liquid.

Preferably the filling, irradiating, and/or advancing steps are carried out while also
15 concurrently: (i) continuously maintaining a dead zone of polymerizable liquid in contact
with said build surface, and (ii) continuously maintaining a gradient of polymerization zone
between said dead zone and said solid polymer and in contact with each thereof, said gradient
of polymerization zone comprising said polymerizable liquid in partially cured form. The
dead zone and gradient of polymerization zone may be maintained through some or all of the
20 formation of the object being made, for example (and in some embodiments) for a time of at
least 5, 10, 20, or 30 seconds, and in some embodiments for a time of at least 1 or 2 minutes.

Apparatus for carrying out the present invention generally comprises:

(a) a support;

(b) a carrier operatively associated with said support on which carrier said three-
25 dimensional object is formed;

(c) an optically transparent member having a build surface, with said build surface
and said carrier defining a build region therebetween;

(d) a liquid polymer supply operatively associated with said build surface and
configured to supply liquid polymer into said build region for solidification or
30 polymerization;

(e) a radiation source configured to irradiate said build region through said optically
transparent member to form a solid polymer from said polymerizable liquid;

(f) optionally at least one drive operatively associated with either said transparent member or said carrier;

(g) a controller operatively associated with said carrier, and/or optionally said at least one drive, and said radiation source for advancing said carrier away from said build surface to form said three-dimensional object from said solid polymer,

with the controller preferably further configured to oscillate or reciprocate said carrier with respect to said build surface to enhance or speed the refilling of said build region with said polymerizable liquid.

In some embodiments, the polymerizable liquid comprises a mixture of (i) a light polymerizable liquid first component, and (ii) a second solidifiable component that is different from the first component. In this case, the method may further include, concurrently with or following the forming of the three dimensional object, solidifying and/or curing the second solidifiable component in the three-dimensional object (e.g., by removing the three-dimensional object as an "intermediate" object from the carrier, and heating and/or microwave irradiating the object).

In some embodiments, the second component comprises a polymerizable liquid solubilized in or suspended in the first component.

In some embodiments, the second component comprises: (i) a polymerizable solid suspended in the first component; (ii) a polymerizable solid solubilized in the first component; or (iii) a polymer solubilized in the first component.

In some embodiments, the three-dimensional intermediate is collapsible or compressible.

In some embodiments, the three-dimensional object, following the further solidifying and/or curing, comprises a polymer blend, interpenetrating polymer network, semi-interpenetrating polymer network, or sequential interpenetrating polymer network formed from the first component and the second component.

In some embodiments, the polymerizable liquid comprises: from 1 or 10 percent by weight to 40, 90 or 99 percent by weight of the first component; and from 1, 10 or 60 percent by weight to 90 or 99 percent by weight of the second component.

In some embodiments, the further solidifying and/or curing step (d) is carried out concurrently with the irradiating step (c) and: (i) the solidifying and/or curing step is carried out by precipitation; or (ii) the irradiating step generates heat from the polymerization of the

first component in an amount sufficient to thermally solidify or polymerize the second component.

In some embodiments, the further solidifying and/or curing step is carried out subsequent to the irradiating step (c) and is carried out by: (i) heating the second solidifiable component; (ii) irradiating the second solidifiable component with light at a wavelength
5 different from that of the light in the irradiating step (c); (iii) contacting the second polymerizable component to water; and/or (iv) contacting the second polymerizable component to a catalyst.

In some embodiments, the second component comprises the precursors to a
10 polyurethane, polyurea, or copolymer thereof, a silicone resin, an epoxy resin, a cyanate ester resin, or a natural rubber; and the solidifying step is carried out by heating and/or microwave irradiating.

In some embodiments, the second component comprises the precursors to a
15 polyurethane, polyurea, or copolymer thereof, and the solidifying and/or curing step is carried out by contacting the second component to water.

In some embodiments, the further solidifying and/or curing step is carried out subsequent to the irradiating step; and the solidifying and/or curing step is carried out under conditions in which the solid polymer scaffold degrades and forms a constituent necessary for the polymerization of the second component.

In some embodiments, the second component comprises precursors to a polyurethane,
20 polyurea, or copolymer thereof, a silicone resin, a ring-opening metathesis polymerization resin, or a click chemistry resin, a cyanate ester resin, and the solidifying and/or curing step is carried out by contacting the second component to a polymerization catalyst.

In some embodiments, the polymerizable liquid comprises a first component (Part
25 A) and at least one additional component (Part B), the first component comprising monomers and/or prepolymers that can be polymerized by exposure to actinic radiation or light; the second component solidifiable on contacting to heat, water, water vapor, light at a different wavelength than that at which the first component is polymerized, catalysts, evaporation of a solvent from the polymerizable liquid, exposure to microwave irradiation, and combinations
30 thereof.

In some embodiments employing two-component polymerizable liquids, the three-dimensional object comprises an interpenetrating polymer network (IPN), the interpenetrating polymer network comprising a sol-gel composition, a hydrophobic-hydrophilic IPN, a

phenolic resin, a polyimide, a conductive polymer, a natural product-based IPN, a sequential IPN, a polyolefin, or a combination thereof.

Non-limiting examples and specific embodiments of the present invention are explained in greater detail in the drawings herein and the specification set forth below. The disclosure of all United States Patent references cited herein are to be incorporated herein by reference in their entirety.

Brief Description of the Drawings

Figure 1 is a schematic illustration of one embodiment of a method of the present invention.

Figure 2 is a perspective view of one embodiment of an apparatus of the present invention.

Figure 3 is a first flow chart illustrating control systems and methods for carrying out the present invention.

Figure 4 is a second flow chart illustrating control systems and methods for carrying out the present invention.

Figure 5 is a third flow chart illustrating control systems and methods for carrying out the present invention.

Figure 6 is a graphic illustration of a process of the invention indicating the position of the carrier in relation to the build surface or plate, where both advancing of the carrier and irradiation of the build region is carried out continuously. Advancing of the carrier is illustrated on the vertical axis, and time is illustrated on the horizontal axis.

Figure 7 is a graphic illustration of another process of the invention indicating the position of the carrier in relation to the build surface or plate, where both advancing of the carrier and irradiation of the build region is carried out stepwise, yet the dead zone and gradient of polymerization are maintained. Advancing of the carrier is again illustrated on the vertical axis, and time is illustrated on the horizontal axis.

Figure 8 is a graphic illustration of still another process of the invention indicating the position of the carrier in relation to the build surface or plate, where both advancing of the carrier and irradiation of the build region is carried out stepwise, the dead zone and gradient of polymerization are maintained, and a reciprocating step is introduced between irradiation steps to enhance the flow of polymerizable liquid into the build region. Advancing of the carrier is again illustrated on the vertical axis, and time is illustrated on the horizontal axis.

Figure 9 is a detailed illustration of a reciprocation step of Figure 23, showing a period of acceleration occurring during the upstroke (*i.e.*, a gradual start of the upstroke) and a period of deceleration occurring during the downstroke (*i.e.*, a gradual end to the downstroke).

5 **Figure 10** schematically illustrates the movement of the carrier (z) over time (t) in the course of fabricating a three-dimensional object by processes of the present invention through a first base (or “adhesion”) zone, a second transition zone, and a third body zone.

10 **Figure 11A** schematically illustrates the movement of the carrier (z) over time (t) in the course of fabricating a three-dimensional object by continuous advancing and continuous exposure.

Figure 11B illustrates the fabrication of a three-dimensional object in a manner similar to Figure 11A, except that illumination is now in an intermittent (or “strobe”) pattern.

15 **Figure 12A** schematically illustrates the movement of the carrier (z) over time (t) in the course of fabricating a three-dimensional object by intermittent (or “stepped”) advancing and intermittent exposure.

Figure 12B illustrates the fabrication of a three-dimensional object in a manner similar to Figure 12A, except that illumination is now in a shortened intermittent (or “strobe”) pattern.

20 **Figure 13A** schematically illustrates the movement of the carrier (z) over time (t) in the course of fabricating a three-dimensional object by oscillatory advancing and intermittent exposure.

Figure 13B illustrates the fabrication of a three-dimensional object in a manner similar to Figure 13A, except that illumination is now in a shortened intermittent (or “strobe”) pattern.

25 **Figure 14A** schematically illustrates one segment of a “strobe” pattern of fabrication, where the duration of the static portion of the carrier has been shortened to near the duration of the “strobe” exposure

30 **Figure 14B** is a schematic illustration of a segment of a strobe pattern of fabrication similar to Figure 14A, except that the carrier is now moving slowly upward during the period of strobe illumination.

Detailed Description of Illustrative Embodiments

The present invention is now described more fully hereinafter with reference to the accompanying drawings, in which embodiments of the invention are shown. This invention may, however, be embodied in many different forms and should not be construed as limited to the embodiments set forth herein; rather these embodiments are provided so that this disclosure will be thorough and complete and will fully convey the scope of the invention to those skilled in the art.

Like numbers refer to like elements throughout. In the figures, the thickness of certain lines, layers, components, elements or features may be exaggerated for clarity. Where used, broken lines illustrate optional features or operations unless specified otherwise.

The terminology used herein is for the purpose of describing particular embodiments only and is not intended to be limiting of the invention. As used herein, the singular forms “a,” “an” and “the” are intended to include plural forms as well, unless the context clearly indicates otherwise. It will be further understood that the terms “comprises” or “comprising,” when used in this specification, specify the presence of stated features, integers, steps, operations, elements components and/or groups or combinations thereof, but do not preclude the presence or addition of one or more other features, integers, steps, operations, elements, components and/or groups or combinations thereof.

As used herein, the term “and/or” includes any and all possible combinations or one or more of the associated listed items, as well as the lack of combinations when interpreted in the alternative (“or”).

Unless otherwise defined, all terms (including technical and scientific terms) used herein have the same meaning as commonly understood by one of ordinary skill in the art to which this invention belongs. It will be further understood that terms, such as those defined in commonly used dictionaries, should be interpreted as having a meaning that is consistent with their meaning in the context of the specification and claims and should not be interpreted in an idealized or overly formal sense unless expressly so defined herein. Well-known functions or constructions may not be described in detail for brevity and/or clarity.

It will be understood that when an element is referred to as being “on,” “attached” to, “connected” to, “coupled” with, “contacting,” etc., another element, it can be directly on, attached to, connected to, coupled with and/or contacting the other element or intervening elements can also be present. In contrast, when an element is referred to as being, for example, “directly on,” “directly attached” to, “directly connected” to, “directly coupled” with or “directly contacting” another element, there are no intervening elements present. It

will also be appreciated by those of skill in the art that references to a structure or feature that is disposed “adjacent” another feature can have portions that overlap or underlie the adjacent feature.

Spatially relative terms, such as “under,” “below,” “lower,” “over,” “upper” and the like, may be used herein for ease of description to describe an element’s or feature’s relationship to another element(s) or feature(s) as illustrated in the figures. It will be understood that the spatially relative terms are intended to encompass different orientations of the device in use or operation in addition to the orientation depicted in the figures. For example, if the device in the figures is inverted, elements described as “under” or “beneath” other elements or features would then be oriented “over” the other elements or features. Thus the exemplary term “under” can encompass both an orientation of over and under. The device may otherwise be oriented (rotated 90 degrees or at other orientations) and the spatially relative descriptors used herein interpreted accordingly. Similarly, the terms “upwardly,” “downwardly,” “vertical,” “horizontal” and the like are used herein for the purpose of explanation only, unless specifically indicated otherwise.

It will be understood that, although the terms first, second, etc., may be used herein to describe various elements, components, regions, layers and/or sections, these elements, components, regions, layers and/or sections should not be limited by these terms. Rather, these terms are only used to distinguish one element, component, region, layer and/or section, from another element, component, region, layer and/or section. Thus, a first element, component, region, layer or section discussed herein could be termed a second element, component, region, layer or section without departing from the teachings of the present invention. The sequence of operations (or steps) is not limited to the order presented in the claims or figures unless specifically indicated otherwise.

25

1. Polymerizable liquids/part A components.

Any suitable polymerizable liquid can be used to enable the present invention. In some embodiments, the polymerizable liquid comprises, in addition to a first component (or “part A”) such as described in this section, a second component (or “part B”) such as described in the “Dual Hardening” section below. The liquid (sometimes also referred to as “liquid resin” “ink,” or simply “resin” herein) can include a monomer, particularly photopolymerizable and/or free radical polymerizable monomers, and a suitable initiator such as a free radical initiator, and combinations thereof. Examples include, but are not limited to,

30

acrylics, methacrylics, acrylamides, styrenics, olefins, halogenated olefins, cyclic alkenes, maleic anhydride, alkenes, alkynes, carbon monoxide, functionalized oligomers, multifunctional cute site monomers, functionalized PEGs, etc., including combinations thereof. Examples of liquid resins, monomers and initiators include but are not limited to those set forth in US Patents Nos. 8,232,043; 8,119,214; 7,935,476; 7,767,728; 7,649,029; 5 WO 2012129968 A1; CN 102715751 A; JP 2012210408 A.

Acid catalyzed polymerizable liquids. While in some embodiments as noted above the polymerizable liquid comprises a free radical polymerizable liquid (in which case an inhibitor may be oxygen as described below), in other embodiments the polymerizable liquid 10 comprises an acid catalyzed, or cationically polymerized, polymerizable liquid. In such embodiments the polymerizable liquid comprises monomers contain groups suitable for acid catalysis, such as epoxide groups, vinyl ether groups, etc.. Thus suitable monomers include olefins such as methoxyethene, 4-methoxystyrene, styrene, 2-methylprop-1-ene, 1,3-butadiene, etc.; heterocyclic monomers (including lactones, lactams, and cyclic amines) 15 such as oxirane, thietane, tetrahydrofuran, oxazoline, 1,3-dioxepane, oxetan-2-one, etc., and combinations thereof. A suitable (generally ionic or non-ionic) photoacid generator (PAG) is included in the acid catalyzed polymerizable liquid, examples of which include, but are not limited to onium salts, sulfonium and iodonium salts, etc., such as diphenyl iodide hexafluorophosphate, diphenyl iodide hexafluoroarsenate, diphenyl iodide 20 hexafluoroantimonate, diphenyl p-methoxyphenyl triflate, diphenyl p-toluenyl triflate, diphenyl p-isobutylphenyl triflate, diphenyl p-tert-butylphenyl triflate, triphenylsulfonium hexafluorophosphate, triphenylsulfonium hexafluoroarsenate, triphenylsulfonium hexafluoroantimonate, triphenylsulfonium triflate, dibutyl-naphthylsulfonium triflate, etc., including mixtures thereof. See, e.g., US Patents Nos. 7,824,839; 7,550,246; 7,534,844; 25 6,692,891; 5,374,500; and 5,017,461; see also *Photoacid Generator Selection Guide for the electronics industry and energy curable coatings* (BASF 2010).

Hydrogels. In some embodiments suitable resins includes photocurable hydrogels like poly(ethylene glycols) (PEG) and gelatins. PEG hydrogels have been used to deliver a variety of biologicals, including Growth factors; however, a great challenge facing PEG 30 hydrogels crosslinked by chain growth polymerizations is the potential for irreversible protein damage. Conditions to maximize release of the biologicals from photopolymerized PEG diacrylate hydrogels can be enhanced by inclusion of affinity binding peptide sequences in the monomer resin solutions, prior to photopolymerization allowing sustained delivery.

Gelatin is a biopolymer frequently used in food, cosmetic, pharmaceutical and photographic industries. It is obtained by thermal denaturation or chemical and physical degradation of collagen. There are three kinds of gelatin, including those found in animals, fish and humans. Gelatin from the skin of cold water fish is considered safe to use in pharmaceutical applications. UV or visible light can be used to crosslink appropriately modified gelatin. Methods for crosslinking gelatin include cure derivatives from dyes such as Rose Bengal.

Photocurable silicone resins. A suitable resin includes photocurable silicones. UV cure silicone rubber, such as Siliopren™ UV Cure Silicone Rubber can be used as can LOCTITE™ Cure Silicone adhesives sealants. Applications include optical instruments, medical and surgical equipment, exterior lighting and enclosures, electrical connectors / sensors, fiber optics and gaskets.

Biodegradable resins. Biodegradable resins are particularly important for implantable devices to deliver drugs or for temporary performance applications, like biodegradable screws and stents (US patents 7,919,162; 6,932,930). Biodegradable copolymers of lactic acid and glycolic acid (PLGA) can be dissolved in PEG dimethacrylate to yield a transparent resin suitable for use. Polycaprolactone and PLGA oligomers can be functionalized with acrylic or methacrylic groups to allow them to be effective resins for use.

Photocurable polyurethanes. A particularly useful resin is photocurable polyurethanes. A photopolymerizable polyurethane composition comprising (1) a polyurethane based on an aliphatic diisocyanate, poly(hexamethylene isophthalate glycol) and, optionally, 1,4-butanediol; (2) a polyfunctional acrylic ester; (3) a photoinitiator; and (4) an anti-oxidant, can be formulated so that it provides a hard, abrasion-resistant, and stain-resistant material (US Patent 4,337,130). Photocurable thermoplastic polyurethane elastomers incorporate photoreactive diacetylene diols as chain extenders.

High performance resins. In some embodiments, high performance resins are used. Such high performance resins may sometimes require the use of heating to melt and/or reduce the viscosity thereof, as noted above and discussed further below. Examples of such resins include, but are not limited to, resins for those materials sometimes referred to as liquid crystalline polymers of esters, ester-imide, and ester-amide oligomers, as described in US Patents Nos. 7,507,784; 6,939,940. Since such resins are sometimes employed as high-temperature thermoset resins, in the present invention they further comprise a suitable photoinitiator such as benzophenone, anthraquinone, and fluoroenone initiators (including derivatives thereof), to initiate cross-linking on irradiation, as discussed further below.

Additional example resins. Particularly useful resins for dental applications include EnvisionTEC's Clear Guide, EnvisionTEC's E-Denstone Material. Particularly useful resins for hearing aid industries include EnvisionTEC's e-Shell 300 Series of resins. Particularly useful resins include EnvisionTEC's HTM140IV High Temperature Mold Material for use
5 directly with vulcanized rubber in molding / casting applications. A particularly useful material for making tough and stiff parts includes EnvisionTEC's RC31 resin. A particularly useful resin for investment casting applications includes EnvisionTEC's Easy Cast EC500.

Additional resin ingredients. The liquid resin or polymerizable material can have solid particles suspended or dispersed therein. Any suitable solid particle can be used,
10 depending upon the end product being fabricated. The particles can be metallic, organic/polymeric, inorganic, or composites or mixtures thereof. The particles can be nonconductive, semi-conductive, or conductive (including metallic and non-metallic or polymer conductors); and the particles can be magnetic, ferromagnetic, paramagnetic, or nonmagnetic. The particles can be of any suitable shape, including spherical, elliptical,
15 cylindrical, etc. The particles can comprise an active agent or detectable compound as described below, though these may also be provided dissolved solubilized in the liquid resin as also discussed below. For example, magnetic or paramagnetic particles or nanoparticles can be employed. The resin or polymerizable material may contain a dispersing agent, such as an ionic surfactant, a non-ionic surfactant, a block copolymer, or the like.

20 The liquid resin can have additional ingredients solubilized therein, including pigments, dyes, active compounds or pharmaceutical compounds, detectable compounds (e.g., fluorescent, phosphorescent, radioactive), etc., again depending upon the particular purpose of the product being fabricated. Examples of such additional ingredients include, but are not limited to, proteins, peptides, nucleic acids (DNA, RNA) such as siRNA, sugars,
25 small organic compounds (drugs and drug-like compounds), etc., including combinations thereof.

Inhibitors of polymerization. Inhibitors or polymerization inhibitors for use in the present invention may be in the form of a liquid or a gas. In some embodiments, gas inhibitors are preferred. The specific inhibitor will depend upon the monomer being
30 polymerized and the polymerization reaction. For free radical polymerization monomers, the inhibitor can conveniently be oxygen, which can be provided in the form of a gas such as air, a gas enriched in oxygen (optionally but in some embodiments preferably containing additional inert gases to reduce combustibility thereof), or in some embodiments pure oxygen

gas. In alternate embodiments, such as where the monomer is polymerized by photoacid generator initiator, the inhibitor can be a base such as ammonia, trace amines (e.g. methyl amine, ethyl amine, di and trialkyl amines such as dimethyl amine, diethyl amine, trimethyl amine, triethyl amine, etc.), or carbon dioxide, including mixtures or combinations thereof.

5 ***Polymerizable liquids carrying live cells.*** In some embodiments, the polymerizable liquid may carry live cells as “particles” therein. Such polymerizable liquids are generally aqueous, and may be oxygenated, and may be considered as “emulsions” where the live cells are the discrete phase. Suitable live cells may be plant cells (e.g., monocot, dicot), animal cells (e.g., mammalian, avian, amphibian, reptile cells), microbial cells (e.g., prokaryote, 10 eukaryote, protozoal, etc.), etc. The cells may be of differentiated cells from or corresponding to any type of tissue (e.g., blood, cartilage, bone, muscle, endocrine gland, exocrine gland, epithelial, endothelial, etc.), or may be undifferentiated cells such as stem cells or progenitor cells. In such embodiments the polymerizable liquid can be one that forms a hydrogel, including but not limited to those described in US Patents Nos. 7,651,683; 7,651,682; 15 7,556,490; 6,602,975; 5,836,313; etc.

2. Apparatus.

A non-limiting embodiment of an apparatus of the invention is shown in **Figure 2**. It comprises a radiation source **11** such as a digital light processor (DLP) providing 20 electromagnetic radiation **12** which through reflective mirror **13** illuminates a build chamber defined by wall **14** and a rigid build plate **15** forming the bottom of the build chamber, which build chamber is filled with liquid resin **16**. The bottom of the chamber **15** is constructed of rigid build plate comprising a rigid semipermeable member as discussed further below. The top of the object under construction **17** is attached to a carrier **18**. The carrier is driven in the 25 vertical direction by linear stage **19**, although alternate structures can be used as discussed below.

A liquid resin reservoir, tubing, pumps liquid level sensors and/or valves can be included to replenish the pool of liquid resin in the build chamber (not shown for clarity) though in some embodiments a simple gravity feed may be employed. Drives/actuators for 30 the carrier or linear stage, along with associated wiring, can be included in accordance with known techniques (again not shown for clarity). The drives/actuators, radiation source, and in some embodiments pumps and liquid level sensors can all be operatively associated with a suitable controller, again in accordance with known techniques.

Build plates 15 used to carry out the present invention generally comprise or consist of a (typically rigid or solid, stationary, and/or fixed) semipermeable (or gas permeable) member, alone or in combination with one or more additional supporting substrates (*e.g.*, clamps and tensioning members to rigidify an otherwise flexible semipermeable material).

5 The rigid semipermeable member can be made of any suitable material that is optically transparent at the relevant wavelengths (or otherwise transparent to the radiation source, whether or not it is visually transparent as perceived by the human eye—*i.e.*, an optically transparent window may in some embodiments be visually opaque), including but not limited to porous or microporous glass, and the rigid gas permeable polymers used for the

10 manufacture of rigid gas permeable contact lenses. *See, e.g.*, Norman G. Gaylord, US Patent No. RE31,406; see also US Patents Nos. 7,862,176; 7,344,731; 7,097,302; 5,349,394; 5,310,571; 5,162,469; 5,141,665; 5,070,170; 4,923,906; and 4,845,089. In some embodiments such materials are characterized as glassy and/or amorphous polymers and/or substantially crosslinked that they are essentially non-swelling. Preferably the rigid

15 semipermeable member is formed of a material that does not swell when contacted to the liquid resin or material to be polymerized (*i.e.*, is “non-swelling”). Suitable materials for the rigid semipermeable member include rigid amorphous fluoropolymers, such as those described in US Patent Nos. 5,308,685 and 5,051,115. For example, such fluoropolymers are particularly useful over silicones that would potentially swell when used in conjunction with

20 organic liquid resin inks to be polymerized. For some liquid resin inks, such as more aqueous-based monomeric systems and / or some polymeric resin ink systems that have low swelling tendencies, silicone based window materials may be suitable. The solubility or permeability of organic liquid resin inks can be dramatically decreased by a number of known parameters including increasing the crosslink density of the window material or

25 increasing the molecular weight of the liquid resin ink. In some embodiments the build plate may be formed from a thin film or sheet of material which is flexible when separated from the apparatus of the invention, but which is clamped and tensioned when installed in the apparatus (*e.g.*, with a tensioning ring) so that it is rendered rigid in the apparatus. Particular materials include TEFLON AF® fluoropolymers, commercially available from DuPont.

30 Additional materials include perfluoropolyether polymers such as described in US Patents Nos. 8,268,446; 8,263,129; 8,158,728; and 7,435,495.

It will be appreciated that essentially all solid materials, and most of those described above, have some inherent “flex” even though they may be considered “rigid,” depending on

factors such as the shape and thickness thereof and environmental factors such as the pressure and temperature to which they are subjected. In addition, the terms “stationary” or “fixed” with respect to the build plate is intended to mean that no mechanical interruption of the process occurs, or no mechanism or structure for mechanical interruption of the process (as in a layer-by-layer method or apparatus) is provided, even if a mechanism for incremental adjustment of the build plate (for example, adjustment that does not lead to or cause collapse of the gradient of polymerization zone) is provided).

The semipermeable member typically comprises a top surface portion, a bottom surface portion, and an edge surface portion. The build surface is on the top surface portion; and the feed surface may be on one, two, or all three of the top surface portion, the bottom surface portion, and/or the edge surface portion. In the embodiment illustrated in **Figure 2** the feed surface is on the bottom surface portion, but alternate configurations where the feed surface is provided on an edge, and/or on the top surface portion (close to but separate or spaced away from the build surface) can be implemented with routine skill.

The semipermeable member has, in some embodiments, a thickness of from 0.01, 0.1 or 1 millimeters to 10 or 100 millimeters, or more (depending upon the size of the item being fabricated, whether or not it is laminated to or in contact with an additional supporting plate such as glass, etc., as discussed further below).

The permeability of the semipermeable member to the polymerization inhibitor will depend upon conditions such as the pressure of the atmosphere and/or inhibitor, the choice of inhibitor, the rate or speed of fabrication, etc. In general, when the inhibitor is oxygen, the permeability of the semipermeable member to oxygen may be from 10 or 20 Barrers, up to 1000 or 2000 Barrers, or more. For example, a semipermeable member with a permeability of 10 Barrers used with a pure oxygen, or highly enriched oxygen, atmosphere under a pressure of 150 PSI may perform substantially the same as a semipermeable member with a permeability of 500 Barrers when the oxygen is supplied from the ambient atmosphere under atmospheric conditions.

Thus, the semipermeable member may comprise a flexible polymer film (having any suitable thickness, *e.g.*, from 0.001, 0.01, 0.05, 0.1 or 1 millimeters to 1, 5, 10, or 100 millimeters, or more), and the build plate may further comprise a tensioning member (*e.g.*, a peripheral clamp and an operatively associated strain member or stretching member, as in a “drum head”; a plurality of peripheral clamps, etc., including combinations thereof) connected to the polymer film and to fix and rigidify the film (*e.g.*, at least sufficiently so that

the film does not stick to the object as the object is advanced and resiliently or elastically rebound therefrom). The film has a top surface and a bottom surface, with the build surface on the top surface and the feed surface preferably on the bottom surface. In other embodiments, the semipermeable member comprises: (i) a polymer film layer (having any suitable thickness, *e.g.*, from 0.001, 0.01, 0.1 or 1 millimeters to 5, 10 or 100 millimeters, or more), having a top surface positioned for contacting said polymerizable liquid and a bottom surface, and (ii) a rigid, gas permeable, optically transparent supporting member (having any suitable thickness, *e.g.*, from 0.01, 0.1 or 1 millimeters to 10, 100, or 200 millimeters, or more), contacting said film layer bottom surface. The supporting member has a top surface contacting the film layer bottom surface, and the supporting member has a bottom surface which may serve as the feed surface for the polymerization inhibitor. Any suitable materials that are semipermeable (that is, permeable to the polymerization inhibitor) may be used. For example, the polymer film or polymer film layer may, for example, be a fluoropolymer film, such as an amorphous thermoplastic fluoropolymer like TEFLON AF 1600™ or TEFLON AF 2400™ fluoropolymer films, or perfluoropolyether (PFPE), particularly a crosslinked PFPE film, or a crosslinked silicone polymer film. The supporting member comprises a silicone or crosslinked silicone polymer member such as a polydimethylsiloxane member, a rigid gas permeable polymer member, or a porous or microporous glass member. Films can be laminated or clamped directly to the rigid supporting member without adhesive (*e.g.*, using PFPE and PDMS materials), or silane coupling agents that react with the upper surface of a PDMS layer can be utilized to adhere to the first polymer film layer. UV-curable, acrylate-functional silicones can also be used as a tie layer between UV-curable PFPEs and rigid PDMS supporting layers.

When configured for placement in the apparatus, the carrier defines a “build region” on the build surface, within the total area of the build surface. Because lateral “throw” (*e.g.*, in the X and/or Y directions) is not required in the present invention to break adhesion between successive layers, as in the Joyce and Chen devices noted previously, the area of the build region within the build surface may be maximized (or conversely, the area of the build surface not devoted to the build region may be minimized). Hence in some embodiments, the total surface area of the build region can occupy at least fifty, sixty, seventy, eighty, or ninety percent of the total surface area of the build surface.

As shown in **Figure 2**, the various components are mounted on a support or frame assembly **20**. While the particular design of the support or frame assembly is not critical and

can assume numerous configurations, in the illustrated embodiment it is comprised of a base 21 to which the radiation source 11 is securely or rigidly attached, a vertical member 22 to which the linear stage is operatively associated, and a horizontal table 23 to which wall 14 is removably or securely attached (or on which the wall is placed), and with the build plate 5 rigidly fixed, either permanently or removably, to form the build chamber as described above.

As noted above, the build plate can consist of a single unitary and integral piece of a rigid semipermeable member, or can comprise additional materials. For example, a porous or microporous glass can be laminated or fixed to a rigid semipermeable material. Or, a semipermeable member as an upper portion can be fixed to a transparent lower member 10 having purging channels formed therein for feeding gas carrying the polymerization inhibitor to the semipermeable member (through which it passes to the build surface to facilitate the formation of a release layer of unpolymerized liquid material, as noted above and below). Such purge channels may extend fully or partially through the base plate: For example, the purge channels may extend partially into the base plate, but then end in the region directly 15 underlying the build surface to avoid introduction of distortion. Specific geometries will depend upon whether the feed surface for the inhibitor into the semipermeable member is located on the same side or opposite side as the build surface, on an edge portion thereof, or a combination of several thereof.

Any suitable radiation source (or combination of sources) can be used, depending upon 20 the particular resin employed, including electron beam and ionizing radiation sources. In a preferred embodiment the radiation source is an actinic radiation source, such as one or more light sources, and in particular one or more ultraviolet light sources. Any suitable light source can be used, such as incandescent lights, fluorescent lights, phosphorescent or luminescent lights, a laser, light-emitting diode, etc., including arrays thereof. The light source preferably 25 includes a pattern-forming element operatively associated with a controller, as noted above. In some embodiments, the light source or pattern forming element comprises a digital (or deformable) micromirror device (DMD) with digital light processing (DLP), a spatial modulator (SLM), or a microelectromechanical system (MEMS) mirror array, a mask (aka a reticle), a silhouette, or a combination thereof. See, US Patent No. 7,902,526. Preferably the 30 light source comprises a spatial light modulation array such as a liquid crystal light valve array or micromirror array or DMD (e.g., with an operatively associated digital light processor, typically in turn under the control of a suitable controller), configured to carry out

exposure or irradiation of the polymerizable liquid without a mask, *e.g.*, by maskless photolithography. *See, e.g.*, US Patents Nos. 6,312,134; 6,248,509; 6,238,852; and 5,691,541.

In some embodiments, as discussed further below, there may be movement in the X and/or Y directions concurrently with movement in the Z direction, with the movement in the X and/or Y direction hence occurring during polymerization of the polymerizable liquid (this is in contrast to the movement described in Y. Chen et al., or M. Joyce, *supra*, which is movement between prior and subsequent polymerization steps for the purpose of replenishing polymerizable liquid). In the present invention such movement may be carried out for purposes such as reducing “burn in” or fouling in a particular zone of the build surface.

Because an advantage of some embodiments of the present invention is that the size of the build surface on the semipermeable member (*i.e.*, the build plate or window) may be reduced due to the absence of a requirement for extensive lateral “throw” as in the Joyce or Chen devices noted above, in the methods, systems and apparatus of the present invention lateral movement (including movement in the X and/or Y direction or combination thereof) of the carrier and object (if such lateral movement is present) is preferably not more than, or less than, 80, 70, 60, 50, 40, 30, 20, or even 10 percent of the width (in the direction of that lateral movement) of the build region.

While in some embodiments the carrier is mounted on an elevator to advance up and away from a stationary build plate, on other embodiments the converse arrangement may be used: That is, the carrier may be fixed and the build plate lowered to thereby advance the carrier away therefrom. Numerous different mechanical configurations will be apparent to those skilled in the art to achieve the same result.

Depending on the choice of material from which the carrier is fabricated, and the choice of polymer or resin from which the article is made, adhesion of the article to the carrier may sometimes be insufficient to retain the article on the carrier through to completion of the finished article or “build.” For example, an aluminum carrier may have lower adhesion than a poly(vinyl chloride) (or “PVC”) carrier. Hence one solution is to employ a carrier comprising a PVC on the surface to which the article being fabricated is polymerized. If this promotes too great an adhesion to conveniently separate the finished part from the carrier, then any of a variety of techniques can be used to further secure the article to a less adhesive carrier, including but not limited to the application of adhesive tape such as “Greener Masking Tape for Basic Painting #2025 High adhesion” to further secure the article to the carrier during fabrication.

3. Controller and process control.

The methods and apparatus of the invention can include process steps and apparatus features to implement process control, including feedback and feed-forward control, to, for example, enhance the speed and/or reliability of the method.

A controller for use in carrying out the present invention may be implemented as hardware circuitry, software, or a combination thereof. In one embodiment, the controller is a general purpose computer that runs software, operatively associated with monitors, drives, pumps, and other components through suitable interface hardware and/or software. Suitable software for the control of a three-dimensional printing or fabrication method and apparatus as described herein includes, but is not limited to, the ReplicatorG open source 3d printing program, 3DPrint™ controller software from 3D systems, Slic3r, Skeinforge, KISSlicer, Repetier-Host, PrintRun, Cura, etc., including combinations thereof.

Process parameters to directly or indirectly monitor, continuously or intermittently, during the process (*e.g.*, during one, some or all of said filling, irradiating and advancing steps) include, but are not limited to, irradiation intensity, temperature of carrier, polymerizable liquid in the build zone, temperature of growing product, temperature of build plate, pressure, speed of advance, pressure, force (*e.g.*, exerted on the build plate through the carrier and product being fabricated), strain (*e.g.*, exerted on the carrier by the growing product being fabricated), thickness of release layer, etc.

Known parameters that may be used in feedback and/or feed-forward control systems include, but are not limited to, expected consumption of polymerizable liquid (*e.g.*, from the known geometry or volume of the article being fabricated), degradation temperature of the polymer being formed from the polymerizable liquid, etc.

Process conditions to directly or indirectly control, continuously or step-wise, in response to a monitored parameter, and/or known parameters (*e.g.*, during any or all of the process steps noted above), include, but are not limited to, rate of supply of polymerizable liquid, temperature, pressure, rate or speed of advance of carrier, intensity of irradiation, duration of irradiation (*e.g.* for each “slice”), etc.

For example, the temperature of the polymerizable liquid in the build zone, or the temperature of the build plate, can be monitored, directly or indirectly with an appropriate thermocouple, non-contact temperature sensor (*e.g.*, an infrared temperature sensor), or other suitable temperature sensor, to determine whether the temperature exceeds the degradation

temperature of the polymerized product. If so, a process parameter may be adjusted through a controller to reduce the temperature in the build zone and/or of the build plate. Suitable process parameters for such adjustment may include: decreasing temperature with a cooler, decreasing the rate of advance of the carrier, decreasing intensity of the irradiation, decreasing duration of radiation exposure, etc.

In addition, the intensity of the irradiation source (*e.g.*, an ultraviolet light source such as a mercury lamp) may be monitored with a photodetector to detect a decrease of intensity from the irradiation source (*e.g.*, through routine degradation thereof during use). If detected, a process parameter may be adjusted through a controller to accommodate the loss of intensity. Suitable process parameters for such adjustment may include: increasing temperature with a heater, decreasing the rate of advance of the carrier, increasing power to the light source, etc.

As another example, control of temperature and/or pressure to enhance fabrication time may be achieved with heaters and coolers (individually, or in combination with one another and separately responsive to a controller), and/or with a pressure supply (*e.g.*, pump, pressure vessel, valves and combinations thereof) and/or a pressure release mechanism such as a controllable valve (individually, or in combination with one another and separately responsive to a controller).

In some embodiments the controller is configured to maintain the gradient of polymerization zone described herein (*see, e.g.*, **Figure 1**) throughout the fabrication of some or all of the final product. The specific configuration (*e.g.*, times, rate or speed of advancing, radiation intensity, temperature, etc.) will depend upon factors such as the nature of the specific polymerizable liquid and the product being created. Configuration to maintain the gradient of polymerization zone may be carried out empirically, by entering a set of process parameters or instructions previously determined, or determined through a series of test runs or “trial and error”; configuration may be provided through pre-determined instructions; configuration may be achieved by suitable monitoring and feedback (as discussed above), combinations thereof, or in any other suitable manner.

In some embodiments, a method and apparatus as described above may be controlled by a software program running in a general purpose computer with suitable interface hardware between that computer and the apparatus described above. Numerous alternatives are commercially available. Non-limiting examples of one combination of components is shown in **Figures 3 to 5**, where “Microcontroller” is Parallax Propeller, the Stepper Motor

Driver is Sparkfun EasyDriver, the LED Driver is a Luxeon Single LED Driver, the USB to Serial is a Parallax USB to Serial converter, and the DLP System is a Texas Instruments LightCrafter system.

5 4. General Methods.

As noted above, the present invention provides a method of forming a three-dimensional object, comprising the steps of: (a) providing a carrier and a build plate, said build plate comprising a semipermeable member, said semipermeable member comprising a build surface and a feed surface separate from said build surface, with said build surface and said carrier defining a build region therebetween, and with said feed surface in fluid contact with a polymerization inhibitor; then (concurrently and/or sequentially) (b) filling said build region with a polymerizable liquid, said polymerizable liquid contacting said build segment, (c) irradiating said build region through said build plate to produce a solid polymerized region in said build region, with a liquid film release layer comprised of said polymerizable liquid formed between said solid polymerized region and said build surface, the polymerization of which liquid film is inhibited by said polymerization inhibitor; and (d) advancing said carrier with said polymerized region adhered thereto away from said build surface on said stationary build plate to create a subsequent build region between said polymerized region and said top zone. In general the method includes (e) continuing and/or repeating steps (b) through (d) to produce a subsequent polymerized region adhered to a previous polymerized region until the continued or repeated deposition of polymerized regions adhered to one another forms said three-dimensional object.

Since no mechanical release of a release layer is required, or no mechanical movement of a build surface to replenish oxygen is required, the method can be carried out in a continuous fashion, though it will be appreciated that the individual steps noted above may be carried out sequentially, concurrently, or a combination thereof. Indeed, the rate of steps can be varied over time depending upon factors such as the density and/or complexity of the region under fabrication.

Also, since mechanical release from a window or from a release layer generally requires that the carrier be advanced a greater distance from the build plate than desired for the next irradiation step, which enables the window to be recoated, and then return of the carrier back closer to the build plate (*e.g.*, a “two steps forward one step back” operation), the present invention in some embodiments permits elimination of this “back-up” step and allows

the carrier to be advanced unidirectionally, or in a single direction, without intervening movement of the window for re-coating, or “snapping” of a pre-formed elastic release-layer. However, in other embodiments of the invention, reciprocation is utilized not for the purpose of obtaining release, but for the purpose of more rapidly filling or pumping polymerizable liquid into the build region.

In some embodiments, the advancing step is carried out sequentially in uniform increments (*e.g.*, of from 0.1 or 1 microns, up to 10 or 100 microns, or more) for each step or increment. In some embodiments, the advancing step is carried out sequentially in variable increments (*e.g.*, each increment ranging from 0.1 or 1 microns, up to 10 or 100 microns, or more) for each step or increment. The size of the increment, along with the rate of advancing, will depend in part upon factors such as temperature, pressure, structure of the article being produced (*e.g.*, size, density, complexity, configuration, etc.)

In other embodiments of the invention, the advancing step is carried out continuously, at a uniform or variable rate.

In some embodiments, the rate of advance (whether carried out sequentially or continuously) is from about 0.1 1, or 10 microns per second, up to about to 100, 1,000, or 10,000 microns per second, again depending again depending on factors such as temperature, pressure, structure of the article being produced, intensity of radiation, etc

As described further below, in some embodiments the filling step is carried out by forcing said polymerizable liquid into said build region under pressure. In such a case, the advancing step or steps may be carried out at a rate or cumulative or average rate of at least 0.1, 1, 10, 50, 100, 500 or 1000 microns per second, or more. In general, the pressure may be whatever is sufficient to increase the rate of said advancing step(s) at least 2, 4, 6, 8 or 10 times as compared to the maximum rate of repetition of said advancing steps in the absence of said pressure. Where the pressure is provided by enclosing an apparatus such as described above in a pressure vessel and carrying the process out in a pressurized atmosphere (*e.g.*, of air, air enriched with oxygen, a blend of gasses, pure oxygen, etc.) a pressure of 10, 20, 30 or 40 pounds per square inch (PSI) up to, 200, 300, 400 or 500 PSI or more, may be used. For fabrication of large irregular objects higher pressures may be less preferred as compared to slower fabrication times due to the cost of a large high pressure vessel. In such an embodiment, both the feed surface and the polymerizable liquid can be are in fluid contact with the same compressed gas (*e.g.*, one comprising from 20 to 95 percent by volume of oxygen, the oxygen serving as the polymerization inhibitor.

On the other hand, when smaller items are fabricated, or a rod or fiber is fabricated that can be removed or exited from the pressure vessel as it is produced through a port or orifice therein, then the size of the pressure vessel can be kept smaller relative to the size of the product being fabricated and higher pressures can (if desired) be more readily utilized.

5 As noted above, the irradiating step is in some embodiments carried out with patterned irradiation. The patterned irradiation may be a fixed pattern or may be a variable pattern created by a pattern generator (*e.g.*, a DLP) as discussed above, depending upon the particular item being fabricated.

10 When the patterned irradiation is a variable pattern rather than a pattern that is held constant over time, then each irradiating step may be any suitable time or duration depending on factors such as the intensity of the irradiation, the presence or absence of dyes in the polymerizable material, the rate of growth, etc. Thus in some embodiments each irradiating step can be from 0.001, 0.01, 0.1, 1 or 10 microseconds, up to 1, 10, or 100 minutes, or more, in duration. The interval between each irradiating step is in some embodiments preferably as
15 brief as possible, *e.g.*, from 0.001, 0.01, 0.1, or 1 microseconds up to 0.1, 1, or 10 seconds.

While the dead zone and the gradient of polymerization zone do not have a strict boundary therebetween (in those locations where the two meet), the thickness of the gradient of polymerization zone is in some embodiments at least as great as the thickness of the dead zone. Thus, in some embodiments, the dead zone has a thickness of from 0.01, 0.1, 1, 2, or 10
20 microns up to 100, 200 or 400 microns, or more, and/or said gradient of polymerization zone and said dead zone together have a thickness of from 1 or 2 microns up to 400, 600, or 1000 microns, or more. Thus the gradient of polymerization zone may be thick or thin depending on the particular process conditions at that time. Where the gradient of polymerization zone is thin, it may also be described as an active surface on the bottom of the growing three-
25 dimensional object, with which monomers can react and continue to form growing polymer chains therewith. In some embodiments, the gradient of polymerization zone, or active surface, is maintained (while polymerizing steps continue) for a time of at least 5, 10, 15, 20 or 30 seconds, up to 5, 10, 15 or 20 minutes or more, or until completion of the three-dimensional product.

30 The method may further comprise the step of disrupting said gradient of polymerization zone for a time sufficient to form a cleavage line in said three-dimensional object (*e.g.*, at a predetermined desired location for intentional cleavage, or at a location in said object where prevention of cleavage or reduction of cleavage is non-critical), and then

reinstating said gradient of polymerization zone (e.g. by pausing, and resuming, the advancing step, increasing, then decreasing, the intensity of irradiation, and combinations thereof

5 In some embodiments the build surface is flat; in other the build surface is irregular such as convexly or concavely curved, or has walls or trenches formed therein. In either case the build surface may be smooth or textured.

10 Curved and/or irregular build plates or build surfaces can be used in fiber or rod formation, to provide different materials to a single object being fabricated (that is, different polymerizable liquids to the same build surface through channels or trenches formed in the build surface, each associated with a separate liquid supply, etc.

Carrier Feed Channels for Polymerizable liquid. While polymerizable liquid may be provided directly to the build plate from a liquid conduit and reservoir system, in some embodiments the carrier include one or more feed channels therein. The carrier feed channels are in fluid communication with the polymerizable liquid supply, for example a reservoir and associated pump. Different carrier feed channels may be in fluid communication with the same supply and operate simultaneously with one another, or different carrier feed channels may be separately controllable from one another (for example, through the provision of a pump and/or valve for each). Separately controllable feed channels may be in fluid communication with a reservoir containing the same polymerizable liquid, or may be in fluid communication with a reservoir containing different polymerizable liquids. Through the use of valve assemblies, different polymerizable liquids may in some embodiments be alternately fed through the same feed channel, if desired.

5. Reciprocating feed of polymerizable liquid.

25 In an embodiment of the present invention, the carrier is vertically reciprocated with respect to the build surface to enhance or speed the refilling of the build region with the polymerizable liquid.

30 In some embodiments, the vertically reciprocating step, which comprises an upstroke and a downstroke, is carried out with the distance of travel of the upstroke being greater than the distance of travel of the downstroke, to thereby concurrently carry out the advancing step (that is, driving the carrier away from the build plate in the Z dimension) in part or in whole.

In some embodiments, the speed of the upstroke gradually accelerates (that is, there is provided a gradual start and/or gradual acceleration of the upstroke, over a period of at least

20, 30, 40, or 50 percent of the total time of the upstroke, until the conclusion of the upstroke, or the change of direction which represents the beginning of the downstroke. Stated differently, the upstroke begins, or starts, gently or gradually.

5 In some embodiments, the speed of the downstroke gradually decelerates (that is, there is provided a gradual termination and/or gradual deceleration of the downstroke, over a period of at least 20, 30, 40, or 50 percent of the total time of the downstroke. Stated differently, the downstroke concludes, or ends, gently or gradually.

10 While in some embodiments there is an abrupt end, or abrupt deceleration, of the upstroke, and an abrupt beginning or deceleration of the downstroke (*e.g.*, a rapid change in vector or direction of travel from upstroke to downstroke), it will be appreciated that gradual transitions may be introduced here as well (*e.g.*, through introduction of a “plateau” or pause in travel between the upstroke and downstroke). It will also be appreciated that, while each reciprocating step may be consist of a single upstroke and downstroke, the reciprocation step may comprise a plurality of 2, 3, 4 or 5 or more linked set of reciprocations, which may e the
15 same or different in frequent and/or amplitude

In some embodiments, the vertically reciprocating step is carried out over a total time of from 0.01 or 0.1 seconds up to 1 or 10 seconds (*e.g.*, per cycle of an upstroke and a downstroke).

20 In some embodiments, the upstroke distance of travel is from 0.02 or 0.2 millimeters (or 20 or 200 microns) to 1 or 10 millimeters (or 1000 to 10,000 microns). The distance of travel of the downstroke may be the same as, or less than, the distance of travel of the upstroke, where a lesser distance of travel for the downstroke serves to achieve the advancing of the carrier away from the build surface as the three-dimensional object is gradually formed. Where a reciprocation step comprises multiple linked reciprocations, the sum
25 distance of travel of all upstrokes in that set is preferably greater than the sum distance of travel of all downstrokes in that set, to achieve the advancing of the carrier away from the build surface as the three-dimensional object is gradually formed.

30 Preferably the vertically reciprocating step, and particularly the upstroke thereof, does not cause the formation of gas bubbles or a gas pocket in the build region, but instead the build region remains filled with the polymerizable liquid throughout the reciprocation steps, and the gradient of polymerization zone or region remains in contact with the “dead zone” and with the growing object being fabricated throughout the reciprocation steps. As will be appreciated, a purpose of the reciprocation is to speed or enhance the refilling of the build

region, particularly where larger build regions are to be refilled with polymerizable liquid, as compared to the speed at which the build region could be refilled without the reciprocation step.

In some embodiments, the advancing step is carried out intermittently at a rate of 1, 2, 5 or 10 individual advances per minute up to 300, 600, or 1000 individual advances per minute, each followed by a pause during which an irradiating step is carried out. It will be appreciated that one or more reciprocation steps (*e.g.*, upstroke plus downstroke) may be carried out within each advancing step. Stated differently, the reciprocating steps may be nested within the advancing steps.

In some embodiments, the individual advances are carried out over an average distance of travel for each advance of from 10 or 50 microns to 100 or 200 microns (optionally including the total distance of travel for each vertically reciprocating step, *e.g.*, the sum of the upstroke distance minus the downstroke distance).

Apparatus for carrying out the invention in which the reciprocation steps described herein are implemented substantially as described above, with the drive associated with the carrier, and/or with an additional drive operatively associated with the transparent member, and with the controller operatively associated with either or both thereof and configured to reciprocate the carrier and transparent member with respect to one another as described above.

6. Increased speed of fabrication by increasing light intensity.

In general, it has been observed that speed of fabrication can increase with increased light intensity. In some embodiments, the light is concentrated or "focused" at the build region to increase the speed of fabrication. This may be accomplished using an optical device such as an objective lens.

The speed of fabrication may be generally proportional to the light intensity. For example, the build speed in millimeters per hour may be calculated by multiplying the light intensity in milliWatts per square centimeter and a multiplier. The multiplier may depend on a variety of factors, including those discussed below. A range of multipliers, from low to high, may be employed. On the low end of the range, the multiplier may be about 10, 15, 20 or 30. On the high end of the multiplier range, the multiplier may be about 150, 300, 400 or more.

The relationships described above are, in general, contemplated for light intensities of from 1, 5 or 10 milliWatts per square centimeter, up to 20 or 50 milliWatts per square centimeter.

5 Certain optical characteristics of the light may be selected to facilitate increased speed of fabrication. By way of example, a band pass filter may be used with a mercury bulb light source to provide 365 ± 10 nm light measured at Full Width Half Maximum (FWHM). By way of further example, a band pass filter may be used with an LED light source to provide 375 ± 15 nm light measured at FWHM.

10 As noted above, polymerizable liquids used in such processes are, in general, free radical polymerizable liquids with oxygen as the inhibitor, or acid-catalyzed or cationically polymerizable liquids with a base as the inhibitor. Some specific polymerizable liquids will of course cure more rapidly or efficiently than others and hence be more amenable to higher speeds, though this may be offset at least in part by further increasing light intensity.

15 At higher light intensities and speeds, the "dead zone" may become thinner as inhibitor is consumed. If the dead zone is lost then the process will be disrupted. In such case, the supply of inhibitor may be enhanced by any suitable means, including providing an enriched and/or pressurized atmosphere of inhibitor, a more porous semipermeable member, a stronger or more powerful inhibitor (particularly where a base is employed), etc.

20 In general, lower viscosity polymerizable liquids are more amenable to higher speeds, particularly for fabrication of articles with a large and/or dense cross section (although this can be offset at least in part by increasing light intensity). Polymerizable liquids with viscosities in the range of 50 or 100 centipoise, up to 600, 800 or 1000 centipoise or more (as measured at room temperature and atmospheric pressure with a suitable device such as a HYDRAMOTION REACTAVISCTM Viscometer (available from Hydramotion Ltd, 1 York Road Business Park, Malton, York YO17 6YA England). In some embodiments, where
25 necessary, the viscosity of the polymerizable liquid can advantageously be reduced by heating the polymerizable liquid, as described above.

30 In some embodiments, such as fabrication of articles with a large and/or dense cross-section, speed of fabrication can be enhanced by introducing reciprocation to "pump" the polymerizable liquid, as described above, and/or the use of feeding the polymerizable liquid through the carrier, as also described above, and/or heating and/or pressurizing the polymerizable liquid, as also described above.

7. Tiling.

It may be desirable to use more than one light engine to preserve resolution and light intensity for larger build sizes. Each light engine may be configured to project an image (e.g., an array of pixels) into the build region such that a plurality of "tiled" images are projected into the build region. As used herein, the term "light engine" can mean an assembly including a light source, a DLP device such as a digital micromirror device and an optical device such as an objective lens. The "light engine" may also include electronics such as a controller that is operatively associated with one or more of the other components.

In some embodiments, the configuration with the overlapped images is employed with some form of "blending" or "smoothing" of the overlapped regions as generally discussed in, for example, U.S. Patent Nos. 7,292,207, 8,102,332, 8,427,391, 8,446,431 and U.S. Patent Application Publication Nos. 2013/0269882, 2013/0278840 and 2013/0321475, the disclosures of which are incorporated herein in their entireties.

The tiled images can allow for larger build areas without sacrificing light intensity, and therefore can facilitate faster build speeds for larger objects. It will be understood that more than two light engine assemblies (and corresponding tiled images) may be employed. Various embodiments of the invention employ at least 4, 8, 16, 32, 64, 128 or more tiled images.

8. Fabrication in multiple zones.

As noted above, embodiments of the invention may carry out the formation of the three-dimensional object through multiple zones or segments of operation. Such a method generally comprises:

- (a) providing a carrier and an optically transparent member having a build surface, the carrier and the build surface defining a build region therebetween, with the carrier positioned adjacent and spaced apart from the build surface at a start position; then
- (b) forming an adhesion segment of the three-dimensional object by:
 - (i) filling the build region with a polymerizable liquid,
 - (ii) irradiating the build region with light through the optically transparent member (e.g., by a single exposure), while
 - (iii) maintaining the carrier stationary or advancing the carrier away from the build surface at a first cumulative rate of advance, to thereby form from the

polymerizable liquid a solid polymer adhesion segment of the object adhered to the carrier; then

(c) optionally but preferably forming a transition segment of the three dimensional object by

5 (i) filling the build region with a polymerizable liquid,
(ii) continuously or intermittently irradiating the build region with light through the optically transparent member, and

(iii) continuously or intermittently advancing (e.g., sequentially or concurrently with the irradiating step) the carrier away from the build surface at a second cumulative rate of advance to thereby form from the polymerizable liquid a transition segment of the object between the adhesion segment and the build surface;

10 wherein the second cumulative rate of advance is greater than the first cumulative rate of advance; and then

(d) forming a body segment of the three dimensional object by:

15 (i) filling the build region with a polymerizable liquid,
(ii) continuously or intermittently irradiating the build region with light through the optically transparent, and

(iii) continuously or intermittently advancing (e.g., sequentially or concurrently with the irradiating step) the carrier away from the build surface at a third cumulative rate of advance, to thereby form from the polymerizable liquid a body segment of the object between the transition segment and the build surface;

20 wherein the third cumulative rate of advance is greater than the first and/or the second cumulative rate of advance.

Note that the start position can be any position among a range of positions (e.g., a range of up to 5 or 10 millimeters or more), and the irradiating step (b)(ii) is carried out at an intensity sufficient to adhere the solid polymer to the carrier when the carrier is at any position within that range of positions. This advantageously reduces the possibility of failure of adhesion of the three-dimensional object to the carrier due to variations in uniformity of the carrier and/or build surfaces, variations inherent in drive systems in positioning the carrier adjacent the build surface, etc.

9. Fabrication with Intermittent (or Strobe”) illumination.

As noted above, in some embodiments the invention may be carried out with the illumination in intermittent periods or burst. In one embodiment, such a method comprises:

providing a carrier and an optically transparent member having a build surface, the carrier and the build surface defining a build region therebetween;

5 filling the build region with a polymerizable liquid,

intermittently irradiating the build region with light through the optically transparent member to form a solid polymer from the polymerizable liquid,

continuously advancing the carrier away from the build surface to form the three-dimensional object from the solid polymer.

10 Another embodiment of such a mode of operation comprises:

providing a carrier and an optically transparent member having a build surface, the carrier and the build surface defining a build region therebetween;

filling the build region with a polymerizable liquid,

15 intermittently irradiating the build region with light through the optically transparent member to form a solid polymer from the polymerizable liquid,

continuously or intermittently advancing (*e.g.*, sequentially or concurrently with the irradiating step) the carrier away from the build surface to form the three-dimensional object from the solid polymer.

In some embodiments, the intermittently irradiating comprises alternating periods of
20 active and inactive illumination, where the average duration of the periods of active illumination is less than the average duration of the periods of inactive illumination (*e.g.*, is not more than 50, 60, or 80 percent thereof).

In other embodiments, the intermittently irradiating comprises alternating periods of
25 active and inactive illumination, where the average duration of the periods of active illumination is the same as or greater than the average duration of the periods of inactive illumination (*e.g.*, is at least 100, 120, 160, or 180 percent thereof).

Examples of such modes of operation are given further below. These features may be combined with any of the other features and operating steps or parameters described herein.

30 **10. DUAL HARDENING POLYMERIZABLE LIQUIDS: PART B.**

As noted above, in some embodiments of the invention, the polymerizable liquid comprises a first light polymerizable component (sometimes referred to as "Part A" herein) and a second component that solidifies by another mechanism, or in a different manner from,

the first component (sometimes referred to as “Part B” herein), typically by further reacting, polymerizing, or chain extending. Numerous embodiments thereof may be carried out. In the following, note that, where particular acrylates such as methacrylates are described, other acrylates may also be used.

5 **Part A chemistry.** As noted above, in some embodiments of the present invention, a resin will have a first component, termed “Part A.” Part A comprises or consists of a mix of monomers and/or prepolymers that can be polymerized by exposure to actinic radiation or light. This resin can have a functionality of 2 or higher (though a resin with a functionality of 1 can also be used when the polymer does not dissolve in its monomer). A purpose of Part A
10 is to “lock” the shape of the object being formed or create a scaffold for the one or more additional components (*e.g.*, Part B). Importantly, Part A is present at or above the minimum quantity needed to maintain the shape of the object being formed after the initial solidification. In some embodiments, this amount corresponds to less than ten, twenty, or thirty percent by weight of the total resin (polymerizable liquid) composition.

15 In some embodiments, Part A can react to form a cross-linked polymer network or a solid homopolymer.

 Examples of suitable reactive end groups suitable for Part A constituents, monomers, or prepolymers include, but are not limited to: acrylates, methacrylates, α -olefins, N-vinyls, acrylamides, methacrylamides, styrenics, epoxides, thiols, 1,3-dienes, vinyl halides,
20 acrylonitriles, vinyl esters, maleimides, and vinyl ethers.

 An aspect of the solidification of Part A is that it provides a scaffold in which a second reactive resin component, termed “Part B,” can solidify during a second step (which may occur concurrently with or following the solidification of Part A). This secondary reaction preferably occurs without significantly distorting the original shape defined during
25 the solidification of Part A. Alternative approaches would lead to a distortion in the original shape in a desired manner.

 In particular embodiments, when used in the methods and apparatus described herein, the solidification of Part A is continuously inhibited during printing within a certain region, by oxygen or amines or other reactive species, to form a liquid interface between the
30 solidified part and an inhibitor-permeable film or window (*e.g.*, is carried out by continuous liquid interphase/interface printing).

Part B chemistry. Part B may comprise, consist of or consist essentially of a mix of monomers and/or prepolymers that possess reactive end groups that participate in a second

solidification reaction after the Part A solidification reaction. In some embodiments, Part B could be added simultaneously to Part A so it is present during the exposure to actinide radiation, or Part B could be infused into the object made during the 3D printing process in a subsequent step. Examples of methods used to solidify Part B include, but are not limited to, contacting the object or scaffold to heat, water or water vapor, light at a different wavelength than that at which Part A is cured, catalysts, (with or without additional heat), evaporation of a solvent from the polymerizable liquid (e.g., using heat, vacuum, or a combination thereof), microwave irradiation, etc., including combinations thereof.

Examples of suitable reactive end group pairs suitable for Part B constituents, monomers or prepolymers include, but are not limited to: epoxy/amine, epoxy/hydroxyl, oxetane/amine, oxetane/alcohol, isocyanate*/hydroxyl, Isocyanate*/amine, isocyanate/carboxylic acid, anhydride/amine, amine/carboxylic acid, amine/ester, hydroxyl/carboxylic acid, hydroxyl/acid chloride, amine/acid chloride, vinyl/Si-H (hydrosilylation), Si-Cl /hydroxyl, Si-Cl/amine, hydroxyl/aldehyde, amine/aldehyde, hydroxymethyl or alkoxymethyl amide/alcohol, aminoplast, alkyne/Azide (also known as one embodiment of "Click Chemistry," along with additional reactions including thiolene, Michael additions, Diels-Alder reactions, nucleophilic substitution reactions, etc.), alkene/Sulfur (polybutadiene vulcanization), alkene/peroxide, alkene/thiol, alkyne/thiol, hydroxyl/halide, isocyanate*/water (polyurethane foams), Si-OH/hydroxyl, Si-OH/water, Si-OH/Si-H (tin catalyzed silicone), Si-OH/Si-OH (tin catalyzed silicone), Perfluorovinyl (coupling to form perfluorocyclobutane), etc., where *Isocyanates include protected isocyanates (e.g. oximes)), diene/dienophiles for Diels-Alder reactions, olefin metathesis polymerization, olefin polymerization using Ziegler-Natta catalysis, ring-opening polymerization (including ring-opening olefin metathesis polymerization, lactams, lactones, Siloxanes, epoxides, cyclic ethers, imines, cyclic acetals, etc.), etc.

Other reactive chemistries suitable for Part B will be recognizable by those skilled in the art. Part B components useful for the formation of polymers described in "Concise Polymeric Materials Encyclopedia" and the "Encyclopedia of Polymer Science and Technology" are hereby incorporated by reference.

Organic peroxides. In some embodiments, an organic peroxide may be included in the polymerizable liquid or resin, for example to facilitate the reaction of potentially unreacted double bonds during heat and/or microwave irradiation curing. Such organic peroxides may be included in the resin or polymerizable liquid in any suitable amount, such

as from 0.001 or 0.01 or 0.1 percent by weight, up to 1, 2, or 3 percent by weight. Examples of suitable organic peroxides include, but are not limited to, 2,5-bis(tert-butylperoxy)-2,5-dimethylhexane (e.g., LUPEROX 101™), dilauroyl peroxide (e.g. LUPEROX LP™), benzoyl peroxide (e.g., LUPEROX A98™), and bis(tert-butylperoxyisopropyl)benzene (e.g., VulCUP R™), etc., including combinations thereof. Such organic peroxides are available from a variety of sources, including but not limited to Arkema (420 rue d'Estienne d'Orves, 92705 Colombes Cedex, France).

Elastomers. A particularly useful embodiment for implementing the invention is for the formation of elastomers. Tough, high-elongation elastomers are difficult to achieve using only liquid UV-curable precursors. However, there exist many thermally cured materials (polyurethanes, silicones, natural rubber) that result in tough, high-elongation elastomers after curing. These thermally curable elastomers on their own are generally incompatible with most 3D printing techniques.

In embodiments of the current invention, small amounts (e.g., less than 20 percent by weight) of a low-viscosity UV curable material (Part A) are blended with thermally-curable precursors to form (preferably tough) elastomers (e.g. polyurethanes, polyureas, or copolymers thereof (e.g., poly(urethane-urea)), and silicones) (Part B). The UV curable component is used to solidify an object into the desired shape using 3D printing as described herein and a scaffold for the elastomer precursors in the polymerizable liquid. The object can then be heated after printing, thereby activating the second component, resulting in an object comprising the elastomer.

Adhesion of formed objects. In some embodiments, it may be useful to define the shapes of multiple objects using the solidification of Part A, align those objects in a particular configuration, such that there is a hermetic seal between the objects, then activate the secondary solidification of Part B. In this manner, strong adhesion between parts can be achieved during production. A particularly useful example may be in the formation and adhesion of sneaker components.

Fusion of particles as Part B. In some embodiments, "Part B" may simply consist of small particles of a pre-formed polymer. After the solidification of Part A, the object may be heated above the glass transition temperature of Part B in order to fuse the entrapped polymeric particles.

Evaporation of solvent as Part B. In some embodiments, "Part B" may consist of a pre-formed polymer dissolved in a solvent. After the solidification of Part A into the desired

object, the object is subjected to a process (e.g. heat + vacuum) that allows for evaporation of the solvent for Part B, thereby solidifying Part B.

Thermally cleavable end groups. In some embodiments, the reactive chemistries in Part A can be thermally cleaved to generate a new reactive species after the solidification of Part A. The newly formed reactive species can further react with Part B in a secondary solidification. An exemplary system is described by Velankar, Pezos and Cooper, *Journal of Applied Polymer Science*, **62**, 1361-1376 (1996). Here, after UV-curing, the acrylate/methacrylate groups in the formed object are thermally cleaved to generate diisocyanate prepolymers that further react with blended chain-extender to give high molecular weight polyurethanes/polyureas within the original cured material or scaffold. Such systems are, in general, dual-hardening systems that employ blocked or reactive blocked prepolymers, as discussed in greater detail below. It may be noted that later work indicates that the thermal cleavage above is actually a displacement reaction of the chain extender (usually a diamine) with the hindered urea, giving the final polyurethanes/polyureas without generating isocyanate intermediates.

Methods of mixing components. In some embodiments, the components may be mixed in a continuous manner prior to being introduced to the printer build plate. This may be done using multi-barrel syringes and mixing nozzles. For example, Part A may comprise or consist of a UV-curable di(meth)acrylate resin, Part B may comprise or consist of a diisocyanate prepolymer and a polyol mixture. The polyol can be blended together in one barrel with Part A and remain unreacted. A second syringe barrel would contain the diisocyanate of Part B. In this manner, the material can be stored without worry of "Part B" solidifying prematurely. Additionally, when the resin is introduced to the printer in this fashion, a constant time is defined between mixing of all components and solidification of Part A.

Additional examples of "dual cure" polymerizable liquids (or "resins"), and methods that may be used in carrying out the present invention include, but are not limited to, those set forth in J. Rolland et al., *Method of Producing Polyurethane Three-Dimensional Objects from Materials having Multiple Mechanisms of Hardening*, PCT Publication No. WO 2015/200179 (published 30 Dec. 2015); J. Rolland et al., *Methods of Producing Three-Dimensional Objects from Materials Having Multiple Mechanisms of Hardening*, PCT Publication No. WO 2015/200173 (published 30 Dec. 2015); J. Rolland et al., *Three-Dimensional Objects Produced from Materials Having Multiple Mechanisms of Hardening*,

PCT Publication No. WO/2015/200189 (published 30 Dec. 2015); J. Rolland et al., *Polyurethane Resins Having Multiple Mechanisms of Hardening for Use in Producing Three-Dimensional Objects* published 30 Dec. 2015); and

J. Rolland et al., *Method of Producing Three-Dimensional Objects from Materials having Multiple Mechanisms of Hardening*, US Patent Application No. 14/977,822 (filed 22 Dec. 2015); J. Rolland et al., *Method of Producing Polyurethane Three-Dimensional Objects from Materials having Multiple Mechanisms of Hardening*, US Patent Application No. 14/977,876 (filed 22 Dec. 2015), J. Rolland et al., *Three-Dimensional Objects Produced from Materials having Multiple Mechanisms of Hardening*, US Patent Application No. 14/977,938 (filed 22 Dec. 2015), and J. Rolland et al., *Polyurethane Resins having Multiple Mechanisms of Hardening for Use in Producing Three-Dimensional Objects*, US Patent Application No. 14/977,974 (filed 22 Dec. 2015);

the disclosures of all of which are incorporated by reference herein in their entirety.

11. Fabrication products.

Three-dimensional products produced by the methods and processes of the present invention may be final, finished or substantially finished products, or may be intermediate products subject to further manufacturing steps such as surface treatment, laser cutting, electric discharge machining, etc., is intended. Intermediate products include products for which further additive manufacturing, in the same or a different apparatus, may be carried out). For example, a fault or cleavage line may be introduced deliberately into an ongoing “build” by disrupting, and then reinstating, the gradient of polymerization zone, to terminate one region of the finished product, or simply because a particular region of the finished product or “build” is less fragile than others.

Numerous different products can be made by the methods and apparatus of the present invention, including both large-scale models or prototypes, small custom products, miniature or microminiature products or devices, etc. Examples include, but are not limited to, medical devices and implantable medical devices such as stents, drug delivery depots, functional structures, microneedle arrays, fibers and rods such as waveguides, micromechanical devices, microfluidic devices, etc.

Thus in some embodiments the product can have a height of from 0.1 or 1 millimeters up to 10 or 100 millimeters, or more, and/or a maximum width of from 0.1 or 1 millimeters up to 10 or 100 millimeters, or more. In other embodiments, the product can have a height of

from 10 or 100 nanometers up to 10 or 100 microns, or more, and/or a maximum width of from 10 or 100 nanometers up to 10 or 100 microns, or more. These are examples only: Maximum size and width depends on the architecture of the particular device and the resolution of the light source and can be adjusted depending upon the particular goal of the embodiment or article being fabricated.

In some embodiments, the ratio of height to width of the product is at least 2:1, 10:1, 50:1, or 100:1, or more, or a width to height ratio of 1:1, 10:1, 50:1, or 100:1, or more.

In some embodiments, the product has at least one, or a plurality of, pores or channels formed therein, as discussed further below.

The processes described herein can produce products with a variety of different properties. Hence in some embodiments the products are rigid; in other embodiments the products are flexible or resilient. In some embodiments, the products are a solid; in other embodiments, the products are a gel such as a hydrogel. In some embodiments, the products have a shape memory (that is, return substantially to a previous shape after being deformed, so long as they are not deformed to the point of structural failure). In some embodiments, the products are unitary (that is, formed of a single polymerizable liquid); in some embodiments, the products are composites (that is, formed of two or more different polymerizable liquids). Particular properties will be determined by factors such as the choice of polymerizable liquid(s) employed.

In some embodiments, the product or article made has at least one overhanging feature (or “overhang”), such as a bridging element between two supporting bodies, or a cantilevered element projecting from one substantially vertical support body. Because of the unidirectional, continuous nature of some embodiments of the present processes, the problem of fault or cleavage lines that form between layers when each layer is polymerized to substantial completion and a substantial time interval occurs before the next pattern is exposed, is substantially reduced. Hence, in some embodiments the methods are particularly advantageous in reducing, or eliminating, the number of support structures for such overhangs that are fabricated concurrently with the article.

12. Additional and alternate methods and apparatus.

Additional examples of apparatus, polymerizable liquids (or “resins”), and methods that may be used in carrying out the present invention include, but are not limited to, those set forth in J. DeSimone et al., *Three-Dimensional Printing Using Tiled Light Engines*, PCT

Publication No. WO/2015/195909 (published 23 Dec. 2015); J. DeSimone et al., *Three-Dimensional Printing Method Using Increased Light Intensity and Apparatus Therefore*, PCT Publication No. WO/2015/195920 (published 23 Dec. 2015), A. Ermoshkin et al., *Three-Dimensional Printing with Reciprocal Feeding of Polymerizable Liquid*, PCT Publication No. WO/2015/195924 (published 23 Dec. 2015); J. Rolland et al., *Method of Producing Polyurethane Three-Dimensional Objects from Materials having Multiple Mechanisms of Hardening*, PCT Publication No. WO 2015/200179 (published 30 Dec. 2015); J. Rolland et al., *Methods of Producing Three-Dimensional Objects from Materials Having Multiple Mechanisms of Hardening*, PCT Publication No. WO 2015/200173 (published 30 Dec. 2015); J. Rolland et al., *Three-Dimensional Objects Produced from Materials Having Multiple Mechanisms of Hardening*, PCT Publication No. WO/2015/200189 (published 30 Dec. 2015); J. Rolland et al., *Polyurethane Resins Having Multiple Mechanisms of Hardening for Use in Producing Three-Dimensional Objects* published 30 Dec. 2015); and J. DeSimone et al., *Methods and Apparatus for Continuous Liquid Interface Production with Rotation*, PCT Publication No. WO/2016/007495, the disclosures of which are incorporated by reference herein in their entirety.

In an alternate embodiment of the invention, the methods may be carried out with a method and apparatus as described in Hull, US Patent No. 5,236,637, at Figure 4, where the polymerizable liquid is floated on top of an immiscible liquid layer (said to be “non-wetting” therein). Here, the immiscible liquid layer serves as the build surface. If so implemented, the immiscible liquid (which may be aqueous or non-aqueous) preferably: (i) has a density greater than the polymerizable liquid, (ii) is immiscible with the polymerizable liquid, and (iii) is wettable with the polymerizable liquid. Ingredients such as surfactants, wetting agents, viscosity-enhancing agents, pigments, and particles may optionally be included in either or both of the polymerizable liquid or immiscible liquid.

While the present invention is preferably carried out by continuous liquid interphase polymerization, as described in detail above, in some embodiments alternate methods and apparatus for bottom-up three-dimension fabrication may be used, including layer-by-layer fabrication. Examples of such methods and apparatus include, but are not limited to, those described U.S. Patents No. 7,438,846 to John and U.S. Patent No. 8,110,135 to El-Siblani, and in U.S. Patent Application Publication Nos. 2013/0292862 to Joyce and 2013/0295212 to Chen et al. The disclosures of these patents and applications are incorporated by reference herein in their entirety.

The present invention is explained in greater detail in the following non-limiting Examples.

EXAMPLE 1

5 Continuous Fabrication with Intermittent Irradiation and Advancing

A process of the present invention is illustrated in **Figure 6**, where the vertical axis illustrates the movement of the carrier away from the build surface. In this embodiment, the vertical movement or advancing step (which can be achieved by driving either the carrier or the build surface, preferably the carrier), is continuous and unidirectional, and the irradiating step is carried out continuously. Polymerization of the article being fabricated occurs from a gradient of polymerization, and hence creation of “layer by layer” fault lines within the article is minimized.

An alternate embodiment of the present invention is illustrated in **Figure 7**. In this embodiment, the advancing step is carried out in a step-by-step manner, with pauses introduced between active advancing of the carrier and build surface away from one another. In addition, the irradiating step is carried out intermittently, in this case during the pauses in the advancing step. We find that, as long as the inhibitor of polymerization is supplied to the dead zone in an amount sufficient to maintain the dead zone and the adjacent gradient of polymerization during the pauses in irradiation and/or advancing, the gradient of polymerization is maintained, and the formation of layers within the article of manufacture is minimized or avoided. Stated differently, the polymerization is continuous, even though the irradiating and advancing steps are not. Sufficient inhibitor can be supplied by any of a variety of techniques, including but not limited to: utilizing a transparent member that is sufficiently permeable to the inhibitor, enriching the inhibitor (*e.g.*, feeding the inhibitor from an inhibitor-enriched and/or pressurized atmosphere), etc. In general, the more rapid the fabrication of the three-dimensional object (that is, the more rapid the cumulative rate of advancing), the more inhibitor will be required to maintain the dead zone and the adjacent gradient of polymerization.

EXAMPLE 2

30 Continuous Fabrication with Reciprocation During Advancing to Enhance Filling of Build Region with Polymerizable Liquid

A still further embodiment of the present invention is illustrated in **Figure 8**. As in Example 1, Fig. 7, above, this embodiment, the advancing step is carried out in a step-by-step manner, with pauses introduced between active advancing of the carrier and build surface away from one another. Also as in Example 1 above, the irradiating step is carried out intermittently, again during the pauses in the advancing step. In this example, however, the ability to maintain the dead zone and gradient of polymerization during the pauses in advancing and irradiating is taken advantage of by introducing a vertical reciprocation during the pauses in irradiation.

We find that vertical reciprocation (driving the carrier and build surface away from and then back towards one another), particularly during pauses in irradiation, serves to enhance the filling of the build region with the polymerizable liquid, apparently by pulling polymerizable liquid into the build region. This is advantageous when larger areas are irradiated or larger parts are fabricated, and filling the central portion of the build region may be rate-limiting to an otherwise rapid fabrication.

Reciprocation in the vertical or Z axis can be carried out at any suitable speed in both directions (and the speed need not be the same in both directions), although it is preferred that the speed when reciprocating away is insufficient to cause the formation of gas bubbles in the build region.

While a single cycle of reciprocation is shown during each pause in irradiation in Figure 23, it will be appreciated that multiple cycles (which may be the same as or different from one another) may be introduced during each pause.

As in Example 1 above, as long as the inhibitor of polymerization is supplied to the dead zone in an amount sufficient to maintain the dead zone and the adjacent gradient of polymerization during the reciprocation, the gradient of polymerization is maintained, the formation of layers within the article of manufacture is minimized or avoided, and the polymerization/fabrication remains continuous, even though the irradiating and advancing steps are not.

EXAMPLE 3

Acceleration during Reciprocation Upstroke and

Deceleration during Reciprocation Downstroke to Enhance Part Quality

We observe that there is a limiting speed of upstroke, and corresponding downstroke, which if exceeded causes a deterioration of quality of the part or object being fabricated

(possibly due to degradation of soft regions within the gradient of polymerization caused by lateral shear forces a resin flow). To reduce these shear forces and/or enhance the quality of the part being fabricated, we introduce variable rates within the upstroke and downstroke, with gradual acceleration occurring during the upstroke and gradual deceleration occurring during the downstroke, as schematically illustrated in **Figure 9**.

EXAMPLE 4

Fabrication in Multiple Zones

Figure 10 schematically illustrates the movement of the carrier (z) over time (t) in the course of fabricating a three-dimensional object by methods as described above, through a first base (or “adhesion”) zone, an optional second transition zone, and a third body zone. The overall process of forming the three-dimensional object is thus divided into three (or two) immediately sequential segments or zones. The zones are preferably carried out in a continuous sequence without pause substantial delay (*e.g.*, greater than 5 or 10 seconds) between the three zones, preferably so that the gradient of polymerization is not disrupted between the zones.

The first base (or “adhesion”) zone includes an initial light or irradiation exposure at a higher dose (longer duration and/or greater intensity) than used in the subsequent transition and/or body zones. This is to obviate the problem of the carrier not being perfectly aligned with the build surface, and/or the problem of variation in the positioning of the carrier from the build surface, at the start of the process, by insuring that the resin is securely polymerized to the carrier. Note an optional reciprocation step (for initial distributing or pumping of the polymerizable liquid in or into the build region) is shown before the carrier is positioned in its initial, start, position. Note that a release layer (not shown) such as a soluble release layer may still be included between the carrier and the initial polymerized material, if desired. In general, a small or minor portion of the three-dimensional object is produced during this base zone (*e.g.*, less than 1, 2 or 5 percent by volume). Similarly, the duration of this base zone is, in general, a small or minor portion of the sum of the durations of the base zone, the optional transition zone, and the body zone (*e.g.*, less than 1, 2 or 5 percent).

Immediately following the first base zone of the process, there is optionally (but preferably) a transition zone. In this embodiment, the duration and/or intensity of the illumination is less, and the displacement of the oscillatory step less, compared to that employed in the base zone as described above. The transition zone may (in the illustrated

embodiment) proceed through from 2 or 5, up to 50 or more oscillatory steps and their corresponding illuminations. In general, an intermediate portion (greater than that formed during the base zone, but less than that formed of during the body zone), of the three dimensional object is produced during the transition zone (*e.g.*, from 1, 2 or 5 percent to 10, 20 or 40 percent by volume). Similarly, the duration of this transition zone is, in general, greater than that of the base zone, but less than that of the body zone (*e.g.*, a duration of from 1, 2 or 5 percent to 10, 20 or 40 percent that of the sum of the durations of the base zone, the transition zone, and the body zone (*e.g.*, less than 1, 2 or 5 percent).

Immediately following the transition zone of the process (or, if no transition zone is included, immediately following the base zone of the process), there is a body zone, during which the remainder of the three-dimensional object is formed. In the illustrated embodiment, the body zone is carried out with illumination at a lower dose than the base zone (and, if present, preferably at a lower dose than that in the transition zone), and the reciprocation steps are (optionally but in some embodiments preferably) carried out at a smaller displacement than that in the base zone (and, if present, optionally but preferably at a lower displacement than in the transition zone). In general, a major portion, typically greater than 60, 80, or 90 percent by volume, of the three-dimensional object is produced during the transition zone. Similarly, the duration of this body zone is, in general, greater than that of the base zone and/or transition zone (*e.g.*, a duration of at least 60, 80, or 90 percent that of the sum of the durations of the base zone, the transition zone, and the body zone).

Note that, in this example, the multiple zones are illustrated in connection with an oscillating mode of fabrication, but the multiple zone fabrication technique described herein may also be implemented with other modes of fabrication as illustrated further in the examples below (with the transition zone illustrated as included, but again being optional).

EXAMPLE 5

Fabrication with Intermittent (or “Strobe”) Illumination

The purpose of a “strobe” mode of operation is to reduce the amount of time that the light or radiation source is on or active (*e.g.*, to not more than 80, 70, 60, 50, 40, or 30 percent of the total time required to complete the fabrication of the three-dimensional object), and increase the intensity thereof (as compared to the intensity required when advancing is carried out at the same cumulative rate of speed without such reduced time of active illumination or radiation), so that the overall dosage of light or radiation otherwise remains

substantially the same. This allows more time for resin to flow into the build region without trying to cure it at the same time. The stobe mode technique can be applied to any of the existing general modes of operation described herein above, including continuous, stepped, and oscillatory modes, as discussed further below.

5 **Figure 11A** schematically illustrates one embodiment of **continuous mode**. In the conventional continuous mode, an image is projected and the carrier starts to move upwards. The image is changed at intervals to represent the cross section of the three-dimensional object being produced corresponding to the height of the build platform. The speed of the motion of the build platform can vary for a number of reasons. As illustrated, often there is a
10 base zone where the primary goal is to adhere the object to the build platform, a body zone which has a speed which is suitable for the whole object being produced, and a transition zone which is a gradual transition from the speed and/or dosages of the base zone to the speeds and/or dosages of the body zone. Note that cure is still carried out so that a gradient of polymerization, which prevents the formation of layer-by-layer fault lines, in the
15 polymerizable liquid in the build region, is preferably retained, and with the carrier (or growing object) remaining in liquid contact with the polymerizable liquid, as discussed above.

Figure 11B schematically illustrates one embodiment of **strobe continuous mode**. In strobe continuous the light intensity is increased but the image is projected in short flashes or
20 intermittent segments. The increased intensity allows the resin to cure more quickly so that the amount of flow during cure is minimal. The time between flashes lets resin flow without being cured at the same time. This can reduce problems caused by trying to cure moving resin, such as pitting.

 In addition, the reduced duty cycle on the light source which is achieved in strobe
25 mode can allow for use of increased intermittent power. For example: If the intensity for the conventional continuous mode was $5\text{mW}/\text{cm}^2$ the intensity could be doubled to $10\text{mW}/\text{cm}^2$ and the time that the image is projected could be reduced to half of the time, or the intensity could be increased 5-fold to $25\text{mW}/\text{cm}^2$ and the time could be reduced to $1/5^{\text{th}}$ of the previous light on time.

30 **Figure 12A** schematically illustrates one embodiment of **stepped mode**: In the conventional stepped mode an image is projected while the build platform is stationary (or moving slowly as compared to more rapid movement in between illumination). When one height increment is sufficiently exposed the image is turned off and the build platform is

moved upwards by some increment. This motion can be at one speed or the speed can vary such as by accelerating from a slow speed when the thickness of uncured resin is thin to faster as the thickness of the uncured resin is thicker. Once the build platform is in the new position the image of the next cross section is projected to sufficiently expose the next height increment.

Figure 12B schematically illustrates one embodiment of **strobe stepped mode**: In the strobe stepped mode the light intensity is increased and the amount of time that the image is projected is reduced. This allows more time for resin flow so the overall speed of the print can be reduced or the speed of movement can be reduced. For example: If the intensity for the conventional stepped mode was $5\text{mW}/\text{cm}^2$ and the build platform moves in increments of 100um in 1 second and the image is projected for 1 second the intensity could be doubled to $10\text{mW}/\text{cm}^2$, the time that the image is projected could be reduced to 0.5 seconds, and the speed of movement could be reduced to 50um/second, or the time that the stage is moving could be reduced to 0.5 seconds. The increased intensity could be as much as 5 fold or more allowing the time allotted for image projection to be reduced to $1/5^{\text{th}}$ or less.

Figure 13A schematically illustrates one embodiment of **oscillatory mode**: In the oscillatory mode an image is again projected while the build platform is stationary (or moving slowly as compared to more rapid movement in-between illuminations). When one height increment is cured the image is turned off and the build platform is moved upwards to pull additional resin into the build zone and then moved back down to the next height increment above the last cured height. This motion can be at one speed or the speed can vary such as by accelerating from a slow speed when the thickness of uncured resin is thin to faster as the thickness of the uncured resin is thicker. Once the build platform is in the new position the image of the next cross section is projected to cure the next height increment.

Figure 13B illustrates one embodiment of **strobe oscillatory mode**. In the strobe oscillatory mode the light intensity is increased and the amount of time that the image is projected is reduced. This allows more time for resin flow so the overall speed of the print can be reduced or the speed of movement can be reduced. For example: If the intensity for the conventional oscillatory mode was $5\text{mW}/\text{cm}^2$ and the build platform moves up by 1mm and back down to an increment of 100um above the previous height in 1 second and the image is projected for 1 second the intensity could be doubled to $10\text{mW}/\text{cm}^2$, the time that the image is projected could be reduced to 0.5 seconds, and the speed of movement could be reduced to by half or the time that the stage is moving could be reduced to 0.5 seconds. The

increased intensity could be as much as 5 fold or more allowing the time allotted for image projection to be reduced to 1/5th or less. Segment "A" of **Figure 13B** is discussed further below.

5 **Figure 14A** illustrates a segment of a fabrication method operated in another embodiment of strobe oscillatory mode. In this embodiment, the duration of the segment during which the carrier is static is shortened to close that of the duration of the strobe illumination, so that the duration of the oscillatory segment may—if desired—be lengthened without changing the cumulative rate of advance and the speed of fabrication.

10 **Figure 14B** illustrates a segment of another embodiment of strobe oscillatory mode, similar to that of Figure 14A, except that the carrier is now advancing during the illumination segment (relatively slowly, as compared to the upstroke of the oscillatory segment).

EXAMPLE 6

Varying of Process Parameters During Fabrication

15 In the methods of Example 13-14, the operating conditions during the body zone are shown as constant throughout that zone. However, various parameters can be altered or modified in the course of the body zone, as discussed further below.

20 A primary reason for altering a parameter during production would be variations in the cross section geometry of the three-dimensional object; that is, smaller (easier to fill), and larger (harder to fill) segments or portions of the same three-dimensional object. For easier to fill segments (*e.g.*, 1-5mm diameter equivalents), the speed of upwards movement could be quick (up to 50-1000m/hr) and/or the pump height could be minimal (*e.g.*, as little as 100 to 300um). For larger cross sectional segments (*e.g.*, 5-500mm diameter equivalents) the speed of upward movement can be slower (*e.g.*, 1-50 mm/hr) and/or the pump height can be larger
25 (*e.g.*, 500 to 5000um). Particular parameters will, of course, vary depending on factors such as illumination intensity, the particular polymerizable liquid (including constituents thereof such as dye and filler concentrations), the particular build surface employed, etc.

30 In some embodiments, the overall light dosage (determined by time and intensity) may be reduced as the "bulk" of the cross section being illuminated increases. Said another way, small points of light may need higher per unit dosage than larger areas of light. Without wishing to be bound to any specific theory, this may relate to the chemical kinematics of the polymerizable liquid. This effect could cause us to *increase* the overall light dosage for *smaller* cross sectional diameter equivalents.

In some embodiments, vary the thickness of each height increment between steps or pumps can be varied. This could be to increase speed with decreased resolution requirements (that is, fabricating a portion that requires less precision or permits more variability, versus a portion of the object that requires greater precision or requires more precise or narrow tolerances). For example, one could change from 100um increments to 200um or 400um increments and group all the curing for the increased thickness into one time period. This time period may be shorter, the same or longer than the combined time for the equivalent smaller increments.

In some embodiments, the light dosage (time and/or intensity) delivered could be varied in particular cross sections (vertical regions of the object) or even in different areas within the same cross section or vertical region. This could be to vary the stiffness or density of particular geometries. This can, for example, be achieved by changing the dosage at different height increments, or changing the grayscale percentage of different zones of each height increment illumination.

The foregoing is illustrative of the present invention, and is not to be construed as limiting thereof. The invention is defined by the following claims, with equivalents of the claims to be included therein.

THAT WHICH IS CLAIMED IS:

1. A method of forming a three-dimensional object, comprising:

(a) providing a carrier and an optically transparent member having a build surface, said carrier and said build surface defining a build region therebetween, with said carrier positioned adjacent and spaced apart from said build surface at a start position; then

(b) forming an adhesion segment of said three-dimensional object by:

(i) filling said build region with a polymerizable liquid,

(ii) irradiating said build region with light through said optically transparent member (e.g., by a single exposure), while

(iii) maintaining said carrier stationary or advancing said carrier away from said build surface at a first cumulative rate of advance, to thereby form from said polymerizable liquid a solid polymer adhesion segment of said object adhered to said carrier; then

(c) optionally but preferably forming a transition segment of said three dimensional object by

(i) filling said build region with a polymerizable liquid,

(ii) continuously or intermittently irradiating said build region with light through said optically transparent member, and

(iii) continuously or intermittently advancing (e.g., sequentially or concurrently with said irradiating step) said carrier away from said build surface at a second cumulative rate of advance to thereby form from said polymerizable liquid a transition segment of said object between said adhesion segment and said build surface;

wherein said second cumulative rate of advance is greater than said first cumulative rate of advance; and then

(d) forming a body segment of said three dimensional object by:

(i) filling said build region with a polymerizable liquid,

(ii) continuously or intermittently irradiating said build region with light through said optically transparent, and

(iii) continuously or intermittently advancing (e.g., sequentially or concurrently with said irradiating step) said carrier away from said build surface at a third cumulative rate of advance, to thereby form from said polymerizable liquid a body segment of said object between said transition segment and said build surface;

wherein said third cumulative rate of advance is greater than said first and/or said second cumulative rate of advance.

2. The method of claim 1, wherein said start position can be any position among a range of positions, and said irradiating step (b)(ii) is carried out at an intensity sufficient to adhere said solid polymer to said carrier when said carrier is at any position within said range of positions.

3. The method of claim 1 or 2, wherein said filling step (d)(i), said irradiating step(d)(ii), and/or said advancing step (d)(iii), and/or wherein said filling step (c)(i), said irradiating step(c)(ii), and/or said advancing step (d)(iii), are carried out while also concurrently:

(i) continuously maintaining a dead zone of polymerizable liquid in contact with said build surface, and

(ii) continuously maintaining a gradient of polymerization zone between said dead zone and said solid polymer and in contact with each thereof, said gradient of polymerization zone comprising said polymerizable liquid in partially cured form.

4. The method of any preceding claim, wherein said build surface is fixed and stationary in the lateral (*e.g.*, X and Y) dimensions.

5. The method of any preceding claim, wherein said advancing is carried out at a cumulative rate (*e.g.*, through all zones) of at least 0.1, 1, 10, 100 or 1000 microns per second.

6. The method of any preceding claim, wherein said optically transparent member comprises a semipermeable member, and said continuously maintaining a dead zone is carried out by feeding an inhibitor of polymerization through said optically transparent member in an amount sufficient to maintain said dead zone and said gradient of polymerization.

7. The method of any preceding claim, wherein said optically transparent member is comprised of a semipermeable polymer (*e.g.*, a fluoropolymer).

8. The method of any preceding claim, wherein said gradient of polymerization zone and said dead zone together have a thickness of from 1 to 1000 microns.

9. The method of any preceding claim, wherein said gradient of polymerization zone is maintained for a time of at least 5, 10, 20, or 30 seconds, or at least 1 or 2 minutes.

10. The method of any preceding claim, further comprising the step of heating said polymerizable liquid to reduce the viscosity thereof in said build region.

11. The method of any preceding claim, wherein said irradiating step is carried out by maskless photolithography.

12. The method of any preceding claim, wherein:
said polymerizable liquid comprises a free radical polymerizable liquid and said inhibitor comprises oxygen; or
said polymerizable liquid comprises an acid-catalyzed or cationically polymerizable liquid, and said inhibitor comprises a base.

13. A method of any preceding claim, wherein:
said polymerizable liquid comprises a mixture of (i) a light polymerizable liquid first component, and (ii) a second solidifiable component that is different from said first component,
said method further comprising:
concurrently with or following the forming of said three dimensional object, solidifying and/or curing said second solidifiable component in said three-dimensional object.

14. The method of claim 13, wherein said second component comprises a polymerizable liquid solubilized in or suspended in said first component.

15. The method of claim 13, wherein said second component comprises:
(i) a polymerizable solid suspended in said first component;
(ii) a polymerizable solid solubilized in said first component; or

(iii) a polymer solubilized in said first component.

16. The method of claim 13, wherein said three-dimensional intermediate is collapsible or compressible.

17. The method of claim 13, wherein said three-dimensional object comprises a polymer blend, interpenetrating polymer network, semi-interpenetrating polymer network, or sequential interpenetrating polymer network formed from said first component and said second component.

18. The method of claim 13, wherein said polymerizable liquid comprises:
from 1 or 10 percent by weight to 40, 90 or 99 percent by weight of said first component; and
from 1, 10 or 60 percent by weight to 90 or 99 percent by weight of said second component.

19. The method of claim 13, wherein said solidifying and/or curing step (d) is carried out concurrently with said irradiating step (c) and:

(i) said solidifying and/or curing step is carried out by precipitation; or
(ii) said irradiating step generates heat from the polymerization of said first component in an amount sufficient to thermally solidify or polymerize said second component.

20. The method of claim 13, wherein said solidifying and/or curing step (d) is carried out subsequent to said irradiating step (c) and is carried out by:

(i) heating said second solidifiable component;
(ii) irradiating said second solidifiable component with light at a wavelength different from that of the light in said irradiating step (c);
(iii) contacting said second polymerizable component to water; and/or
(iv) contacting said second polymerizable component to a catalyst.

21. The method of claim 13, wherein: said second component comprises the precursors to a polyurethane, polyurea, or copolymer thereof, a silicone resin, an epoxy resin,

a cyanate ester resin, or a natural rubber; and said solidifying step is carried out by heating and/or microwave irradiating.

22. The method of claim 13, wherein:

said second component comprises the precursors to a polyurethane, polyurea, or copolymer thereof, and

said solidifying and/or curing step is carried out by contacting said second component to water.

23. The method of claim 13, wherein:

said solidifying and/or curing step (d) is carried out subsequent to said irradiating step; and

said solidifying and/or curing step (d) is carried out under conditions in which said solid polymer scaffold degrades and forms a constituent necessary for the polymerization of said second component.

24. The method of claim 13, wherein:

said second component comprises precursors to a polyurethane, polyurea, or copolymer thereof, a silicone resin, a ring-opening metathesis polymerization resin, or a click chemistry resin, a cyanate ester resin, and

said solidifying and/or curing step is carried out by contacting said second component to a polymerization catalyst.

25. The method of claim 13, wherein said polymerizable liquid comprises a first component (Part A) and at least one additional component (Part B),

said first component comprising monomers and/or prepolymers that can be polymerized by exposure to actinic radiation or light;

said second component solidifiable on contacting to heat, water, water vapor, light at a different wavelength than that at which said first component is polymerized, catalysts, evaporation of a solvent from the polymerizable liquid, exposure to microwave irradiation, and combinations thereof.

26. The method of claim 25, said first component monomers and/or prepolymers comprising reactive end groups selected from the group consisting of acrylates, methacrylates, α -olefins, N-vinyls, acrylamides, methacrylamides, styrenics, epoxides, thiols, 1,3-dienes, vinyl halides, acrylonitriles, vinyl esters, maleimides, and vinyl ethers.

27. The method of claim 25, said additional component comprising monomers and/or prepolymers comprising reactive end groups selected from the group consisting of: epoxy/amine, epoxy/hydroxyl, oxetane/amine, oxetane/alcohol, isocyanate/hydroxyl, isocyanate/amine, isocyanate/carboxylic acid, cyanate ester, anhydride/amine, amine/carboxylic acid, amine/ester, hydroxyl/carboxylic acid, hydroxyl/acid chloride, amine/acid chloride, vinyl/Si-H, Si-Cl/hydroxyl, Si-Cl/amine, hydroxyl/aldehyde, amine/aldehyde, hydroxymethyl or alkoxymethyl amide/alcohol, aminoplast, alkyne/azide, click chemistry reactive groups, alkene/sulfur, alkene/thiol, alkyne/thiol, hydroxyl/halide, isocyanate/water, Si-OH/hydroxyl, Si-OH/water, Si-OH/Si-H, Si-OH/Si-OH, perfluorovinyl, diene/dienophiles, olefin metathesis polymerization groups, olefin polymerization groups for Ziegler-Natta catalysis, and ring-opening polymerization groups and mixtures thereof.

28. The method of claim 13, wherein said three-dimensional object comprises an interpenetrating polymer network (IPN), said interpenetrating polymer network comprising a sol-gel composition, a hydrophobic-hydrophilic IPN, a phenolic resin, a polyimide, a conductive polymer, a natural product-based IPN, a sequential IPN, a polyolefin, or a combination thereof.

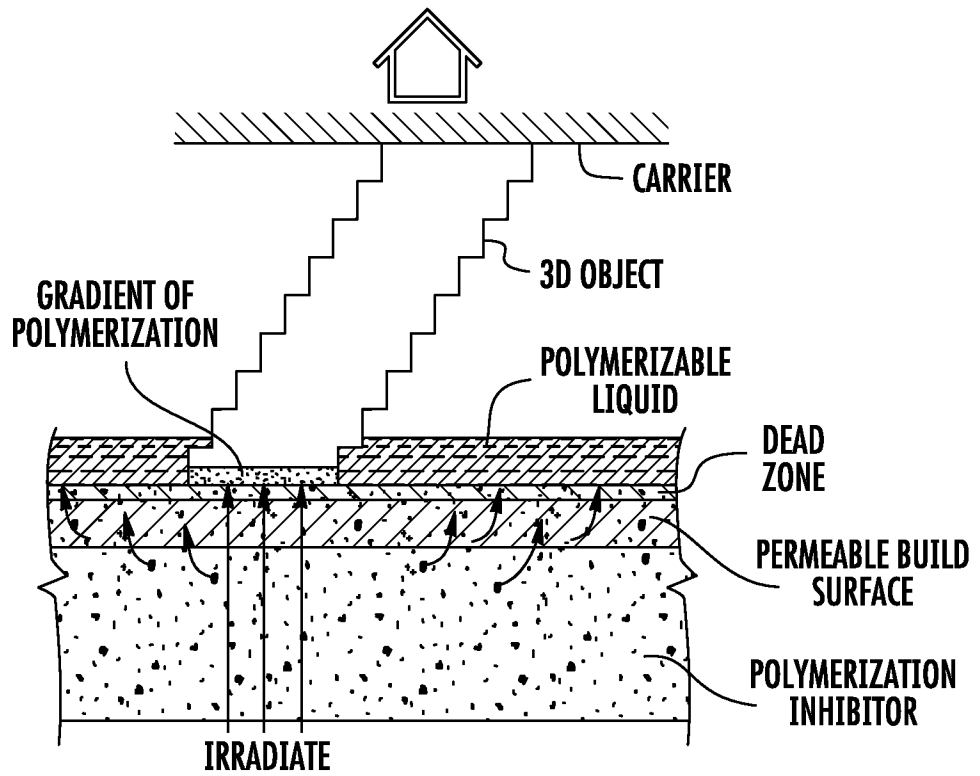

FIG. 1

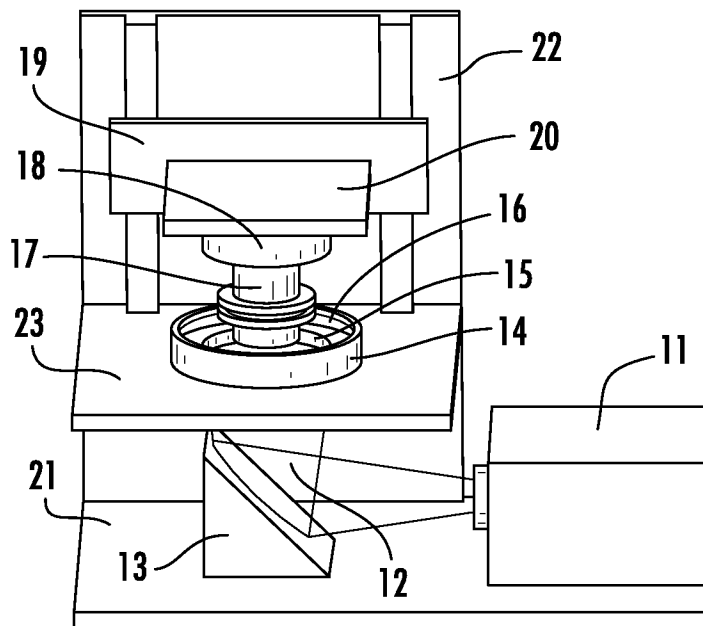

FIG. 2

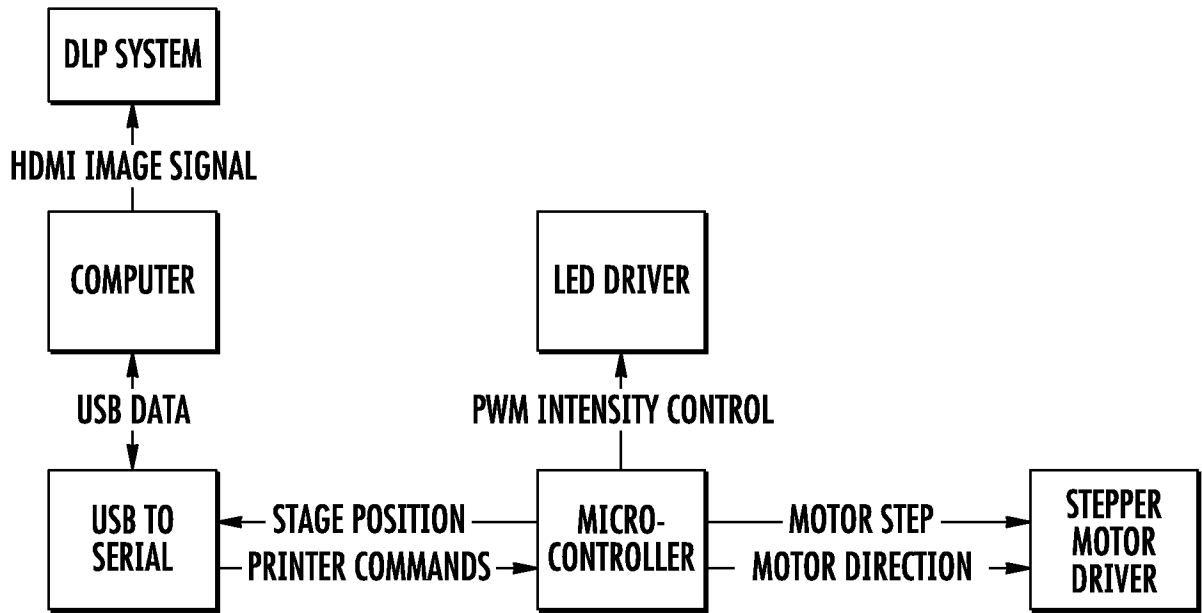

FIG. 3

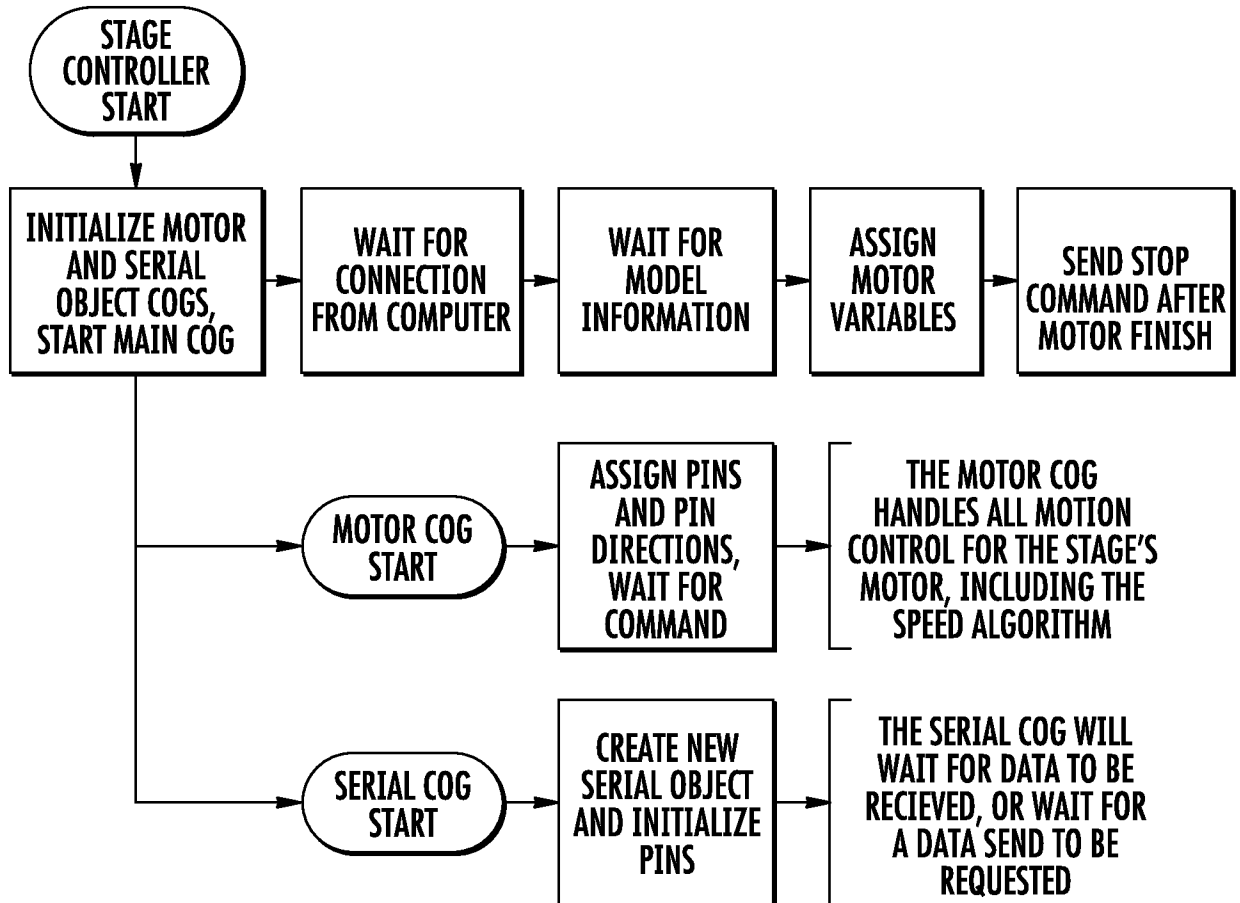

FIG. 4

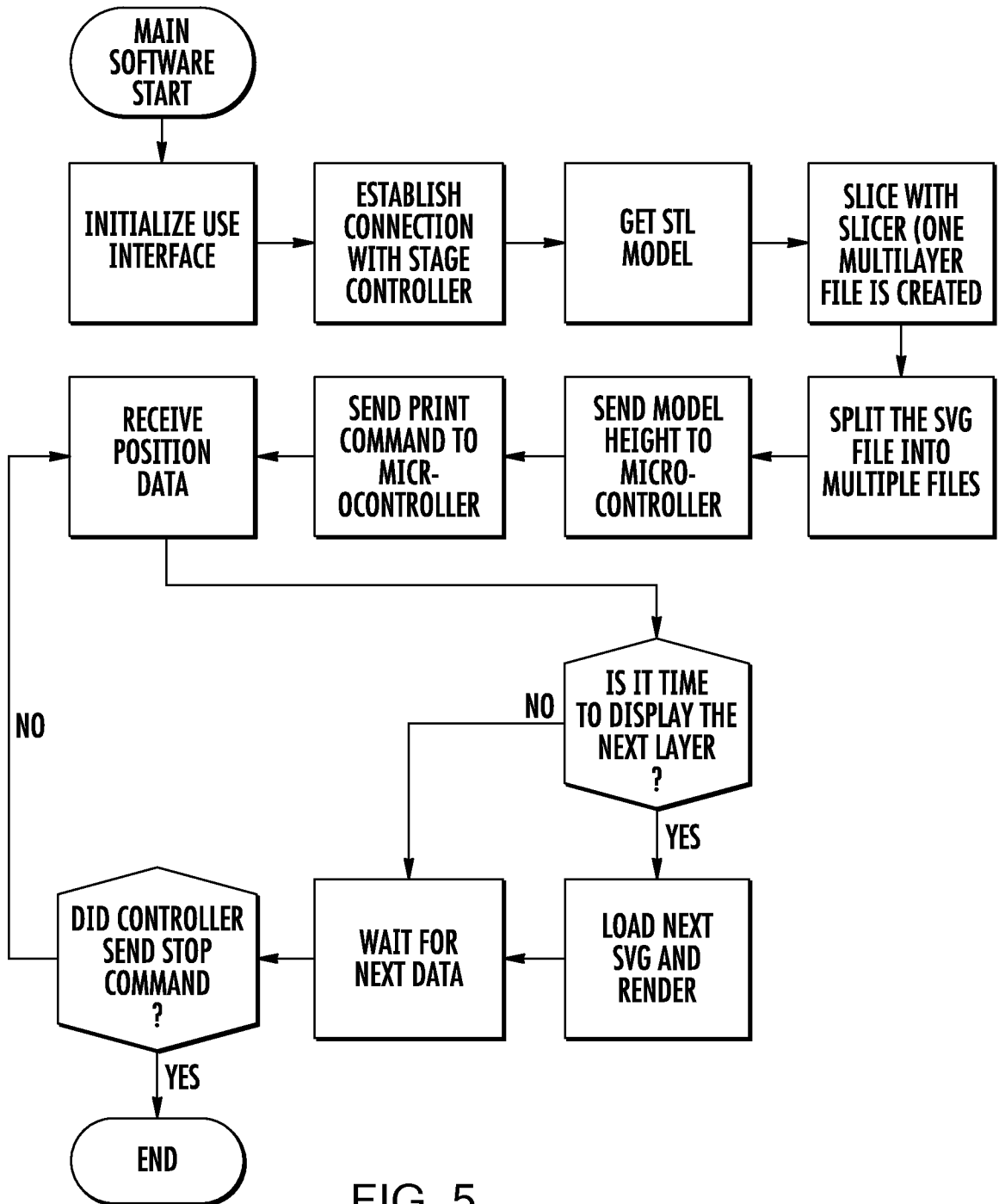

FIG. 5

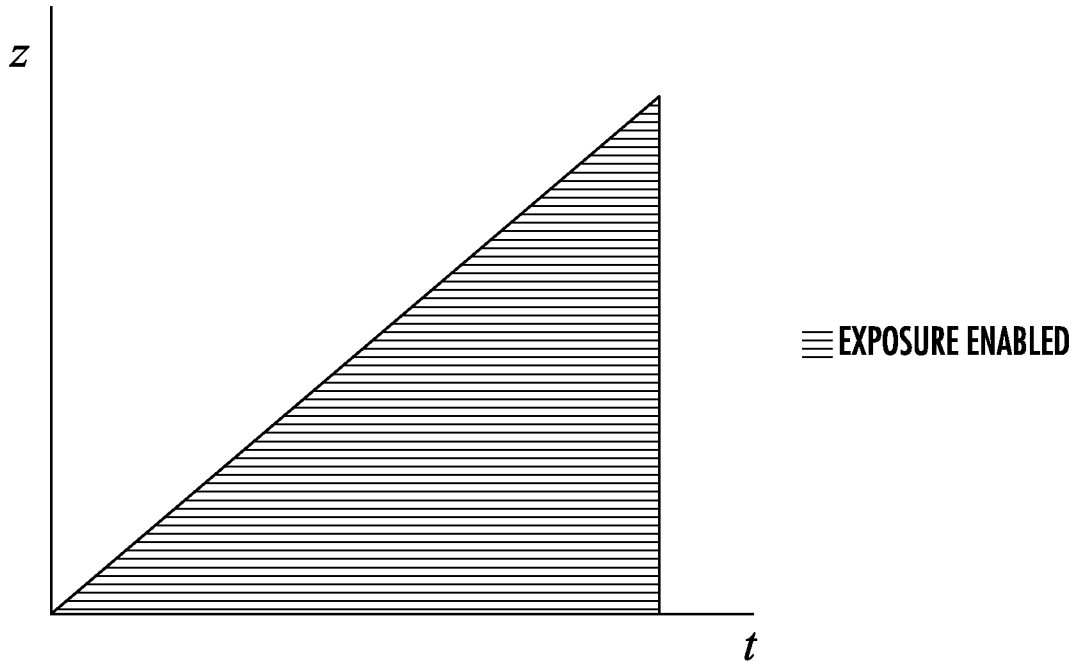

FIG. 6

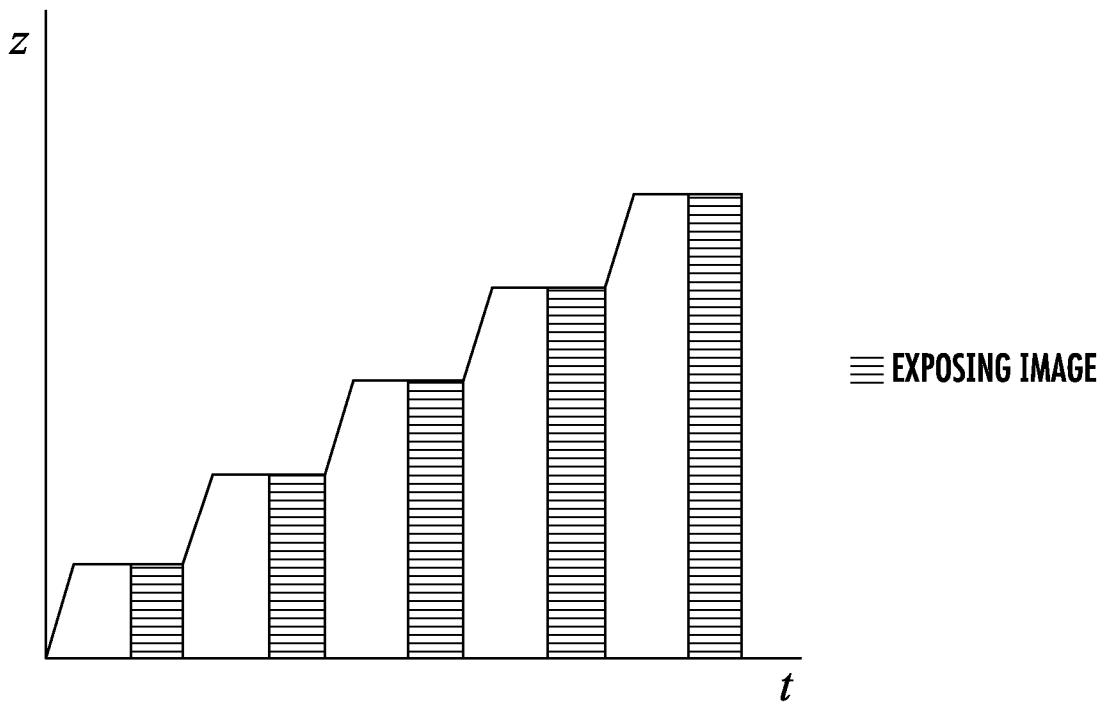

FIG. 7

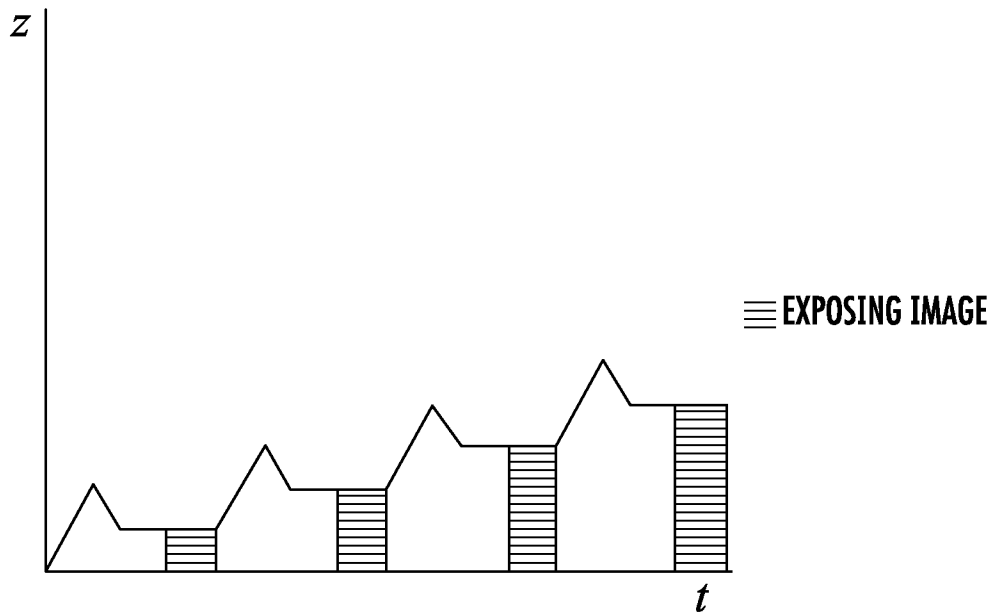

FIG. 8

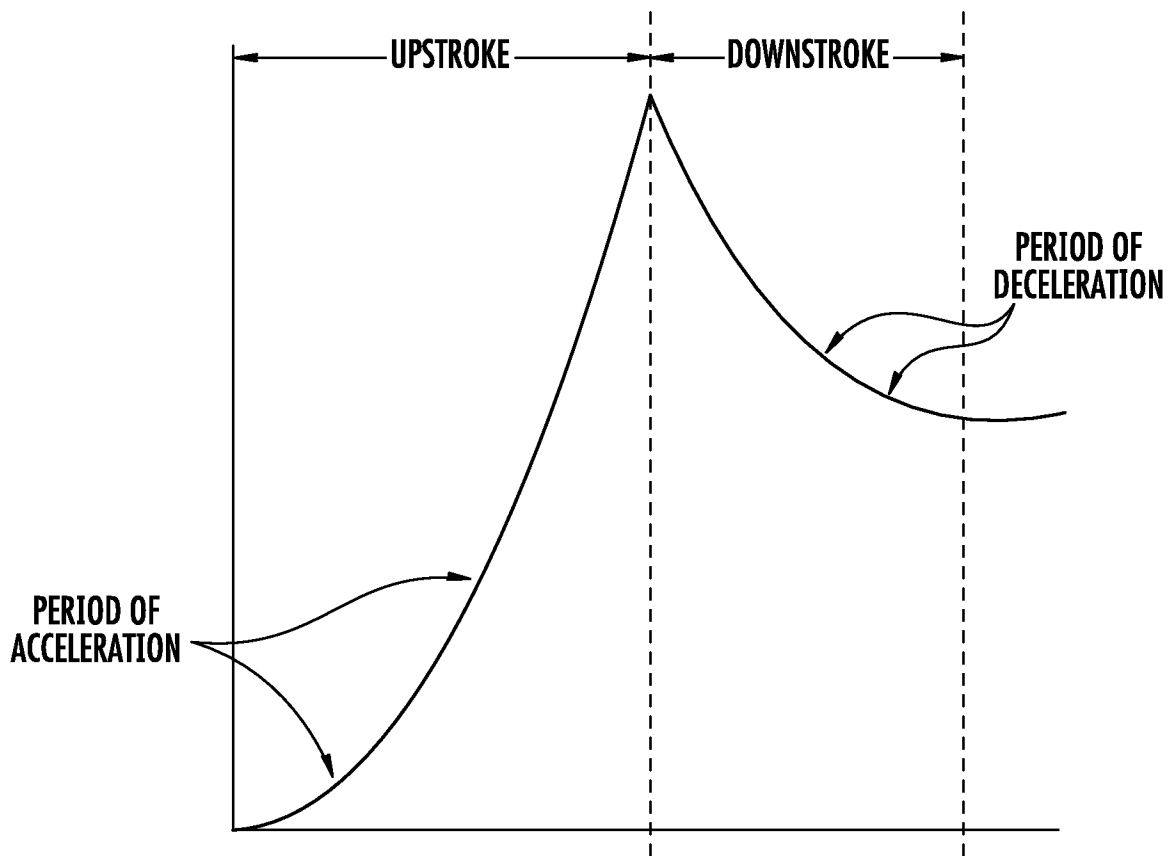

FIG. 9

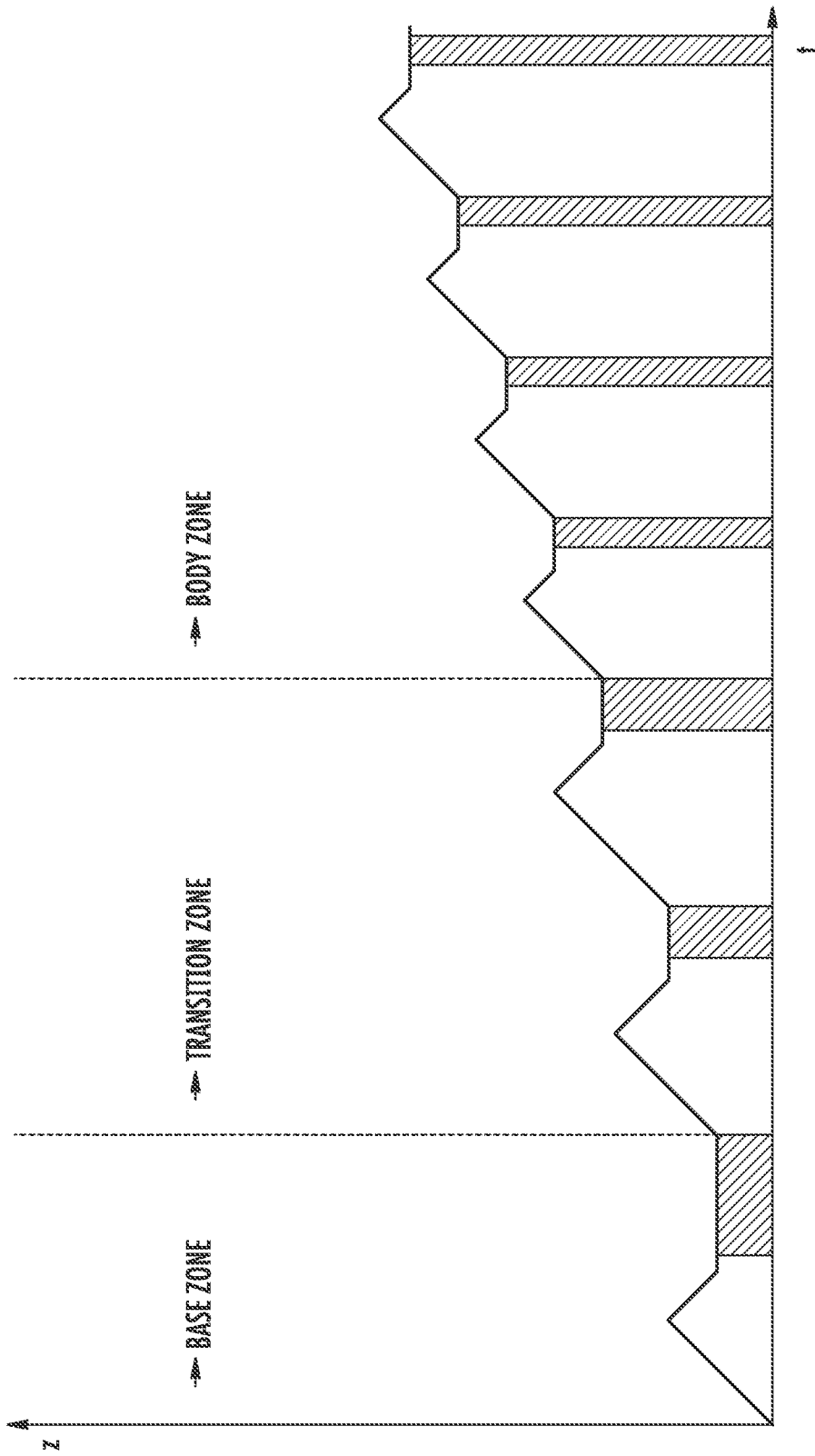

FIG. 10

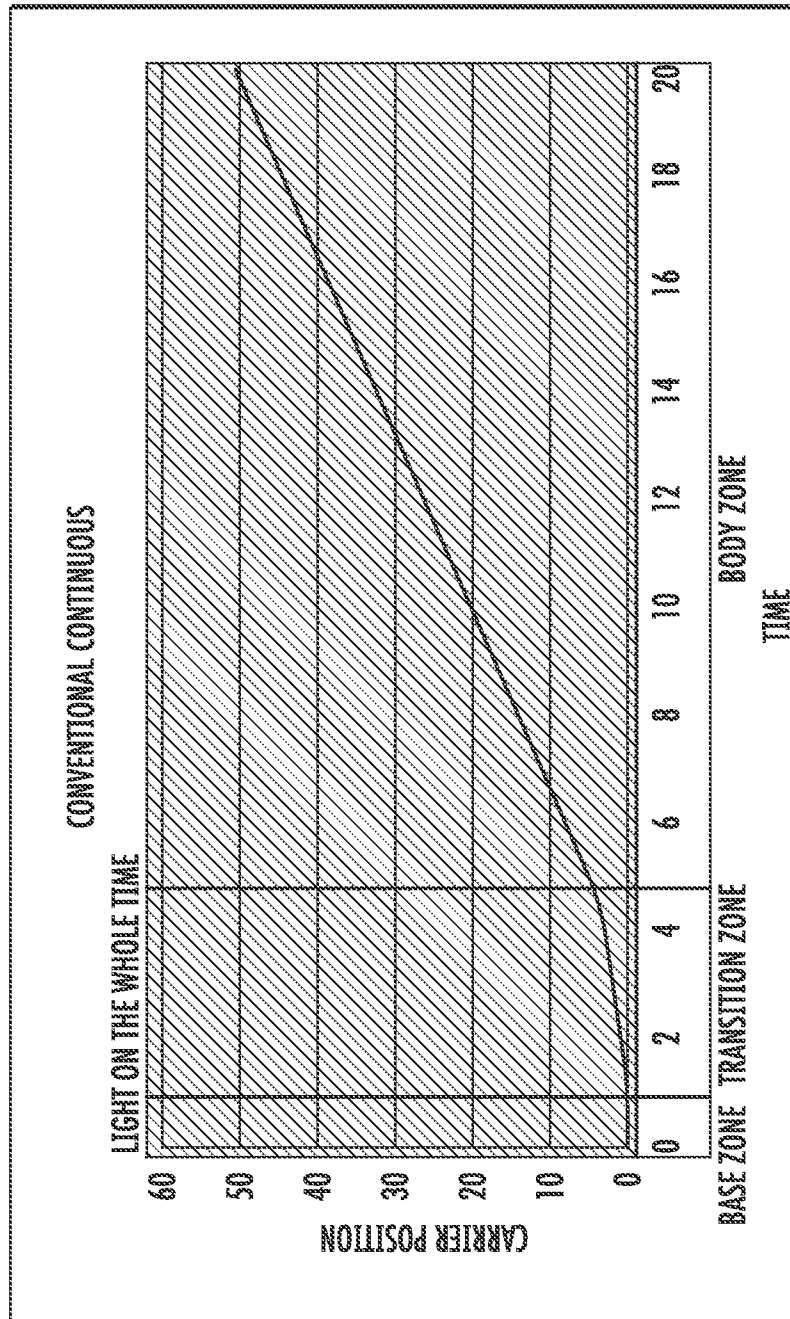

FIG. 11A

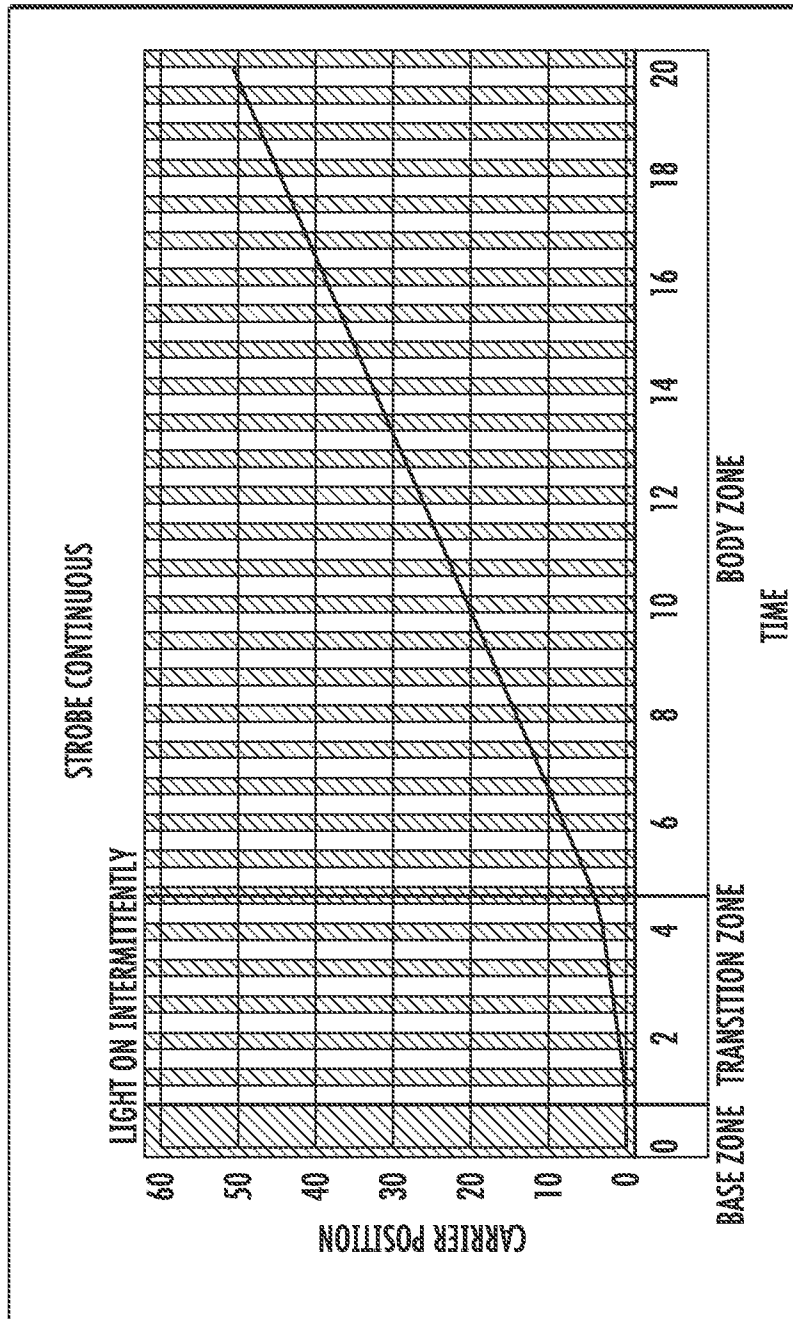

FIG. 11B

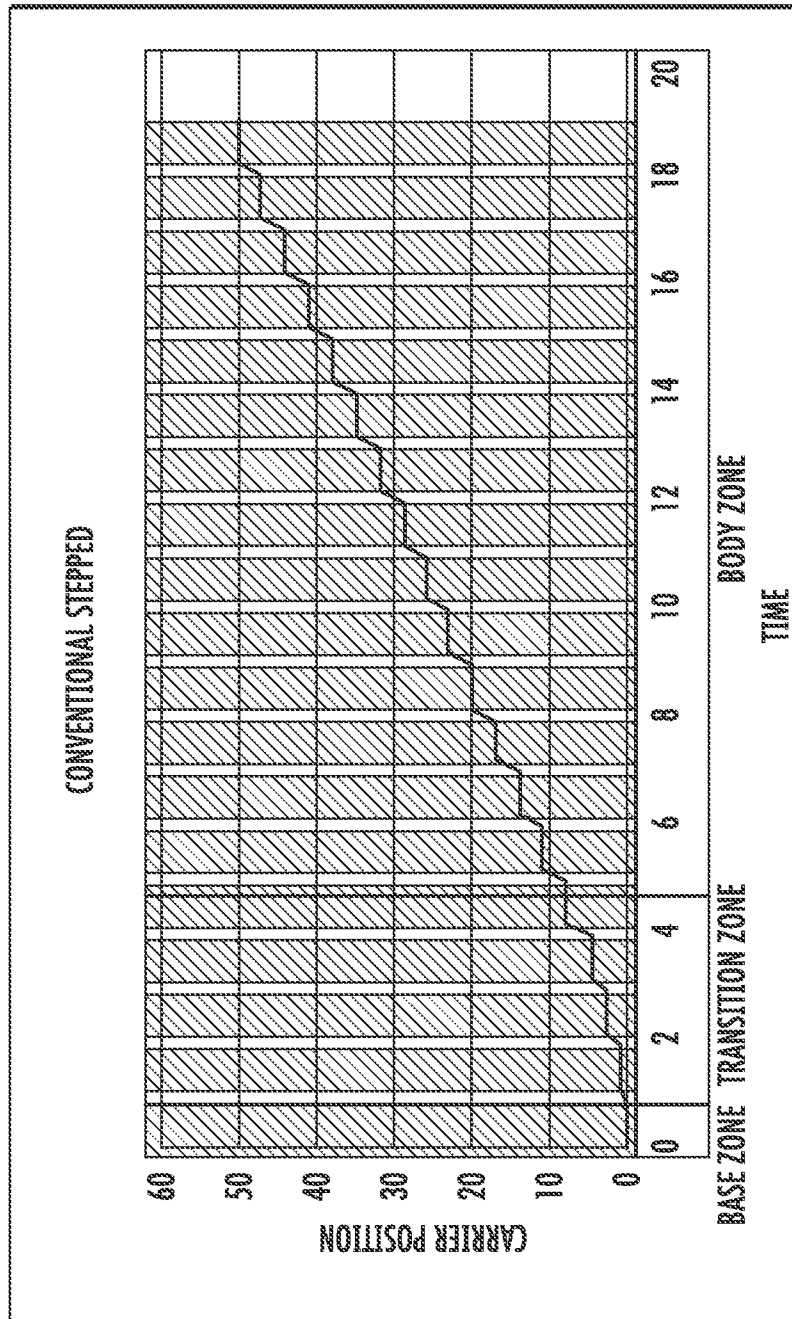

FIG. 12A

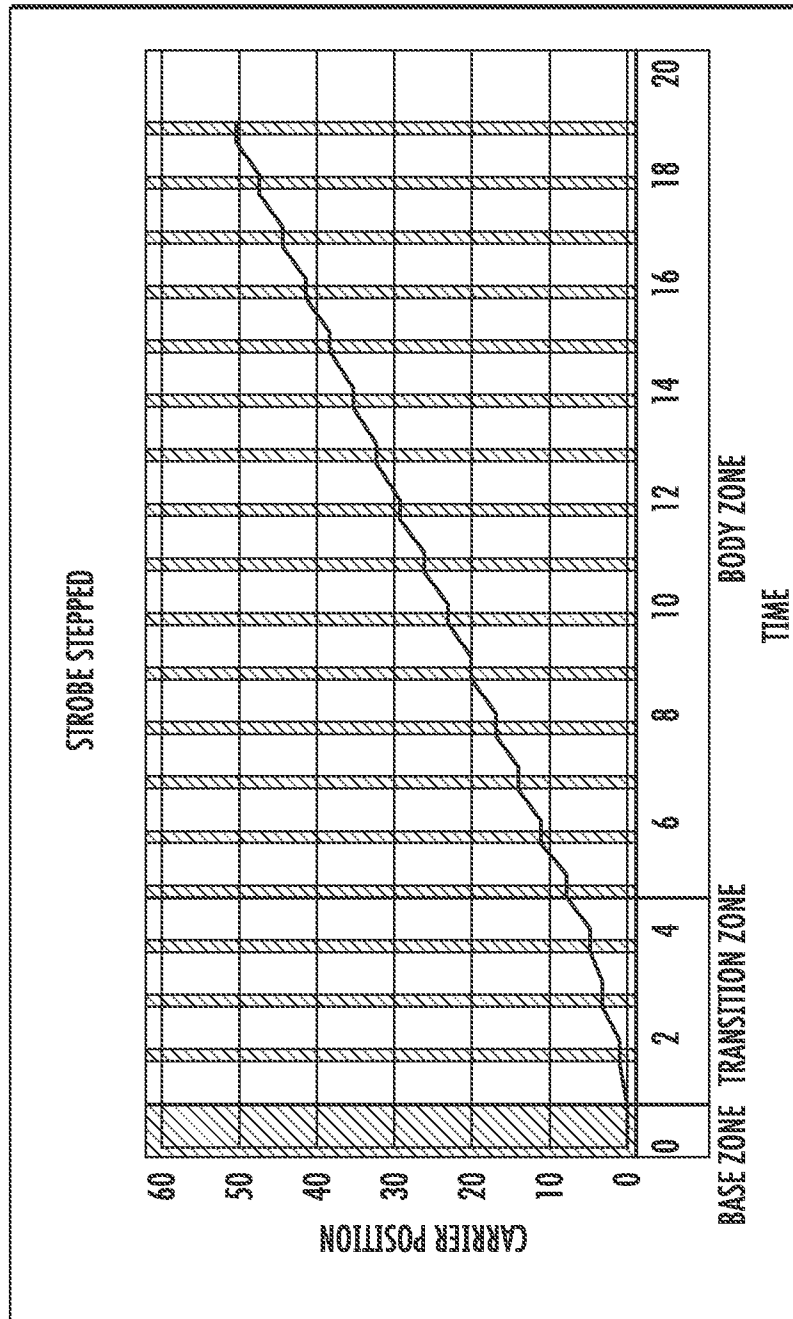

FIG. 12B

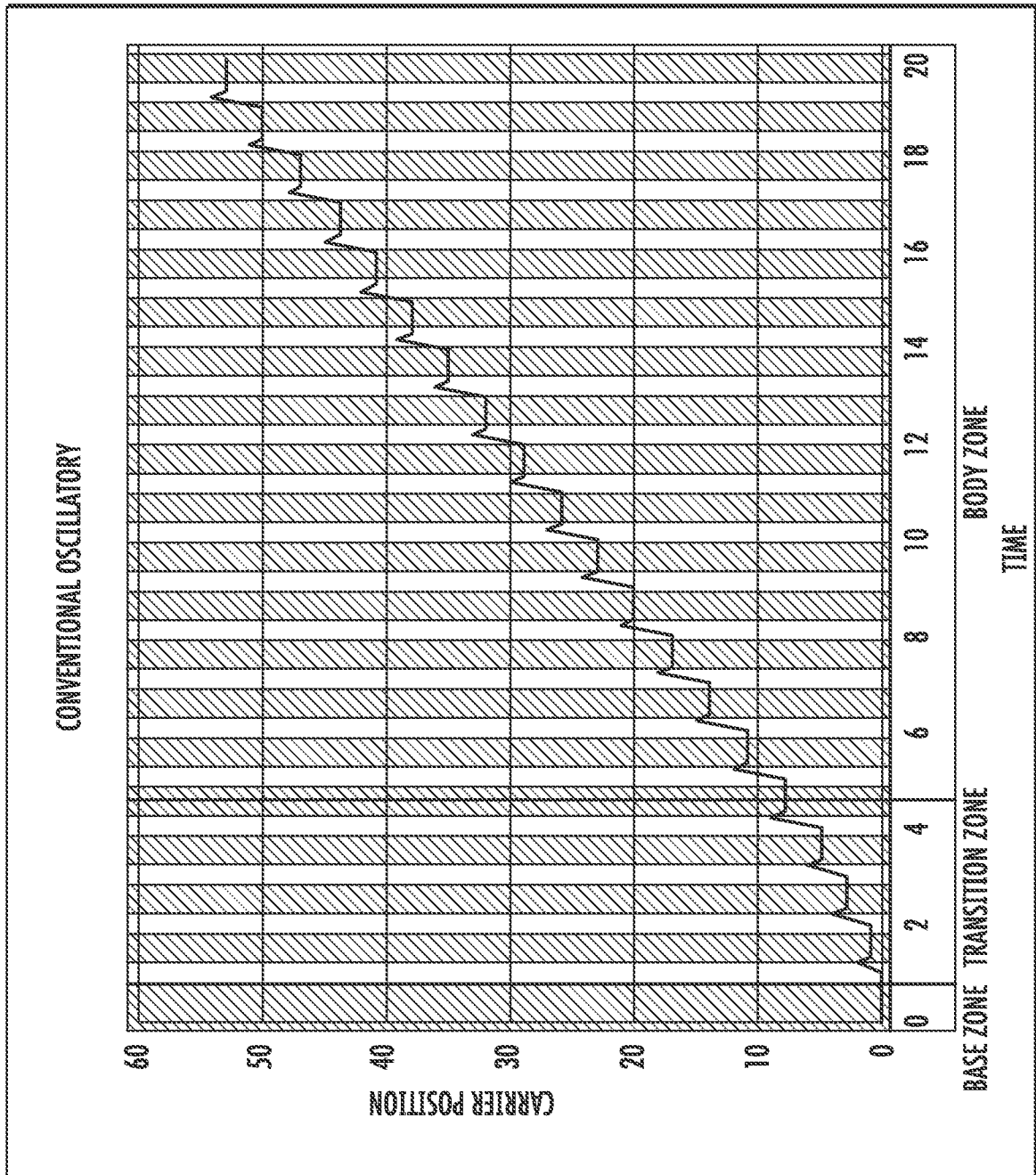

FIG. 13A

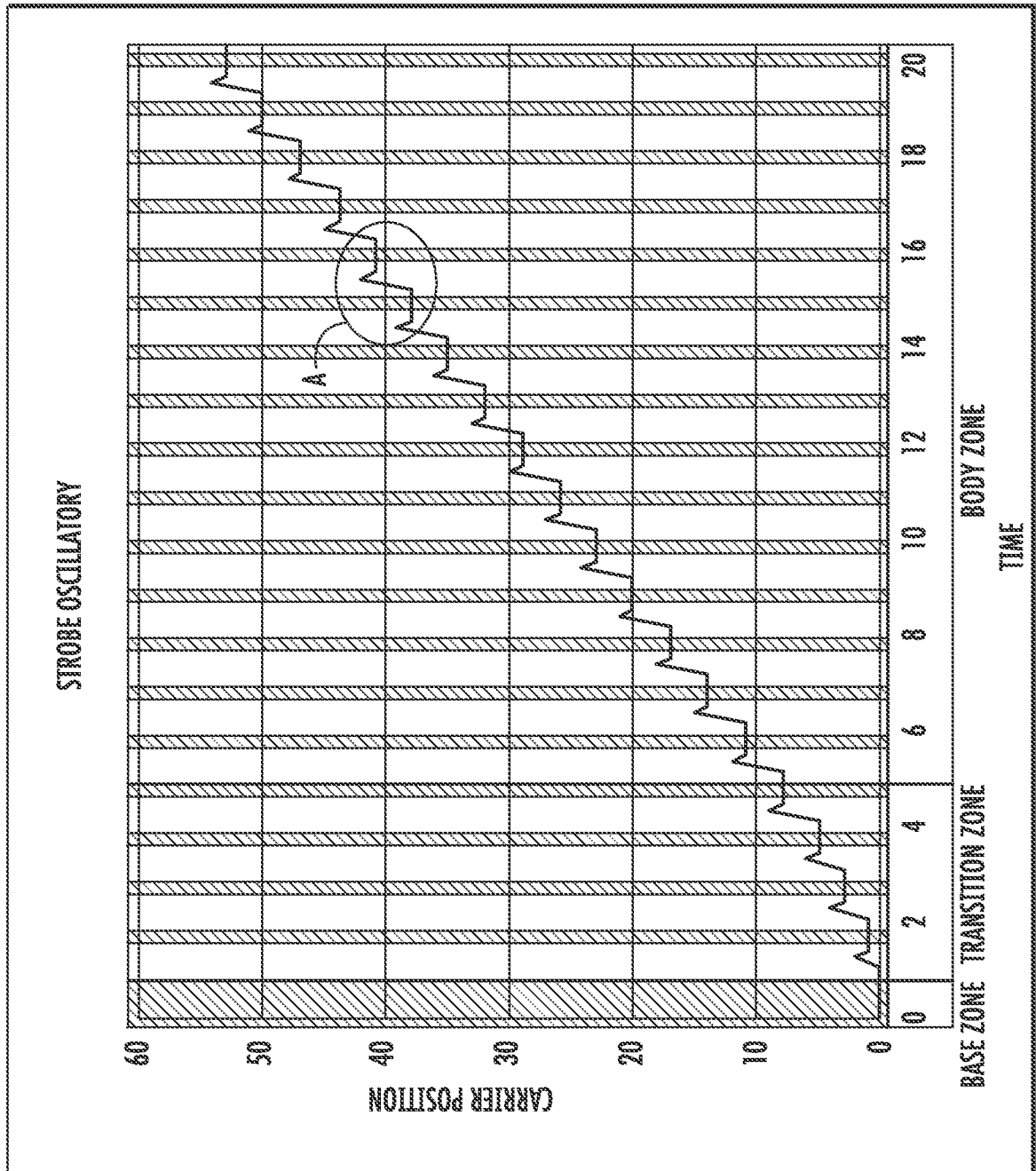

FIG. 13B

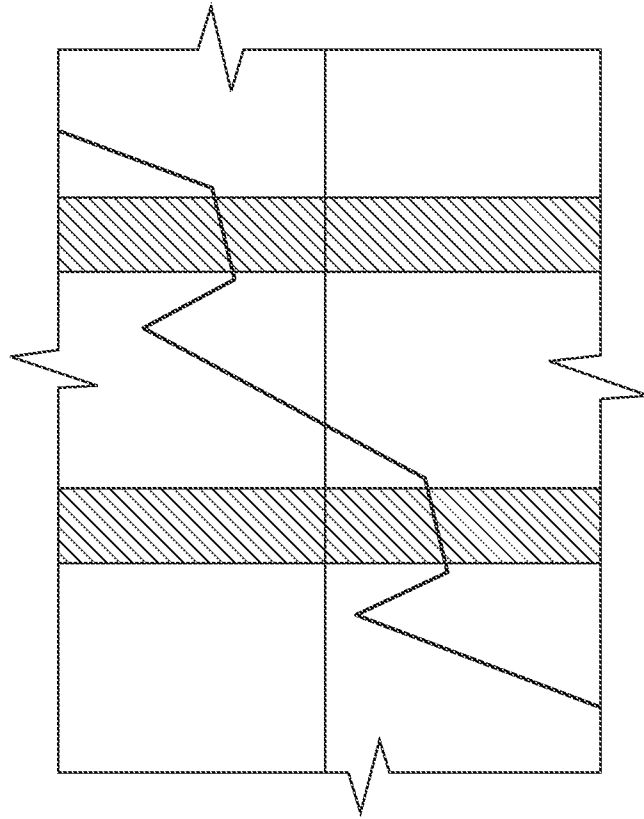

FIG. 14B

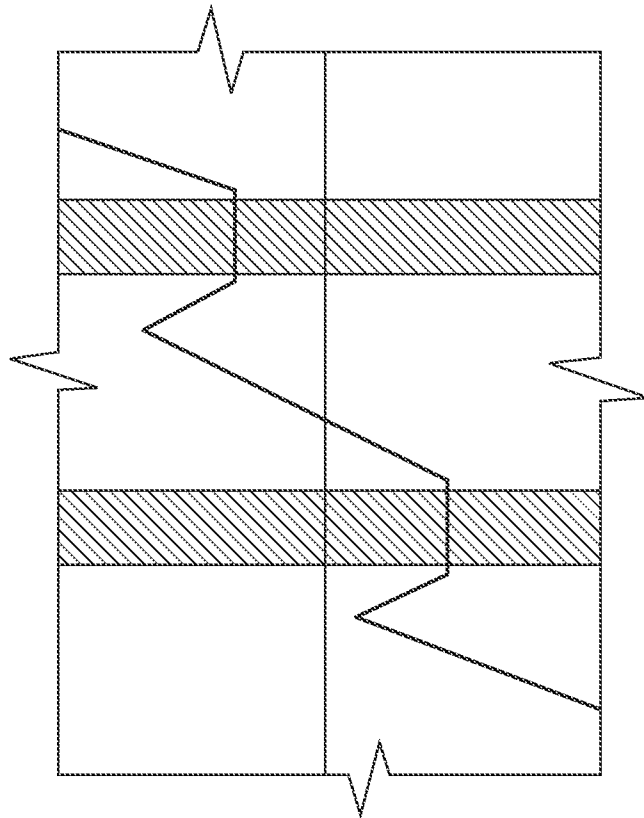

FIG. 14A

INTERNATIONAL SEARCH REPORT

International application No
PCT/US2016/016304

A. CLASSIFICATION OF SUBJECT MATTER
 INV. B29C67/00
 ADD.
 According to International Patent Classification (IPC) or to both national classification and IPC

B. FIELDS SEARCHED
 Minimum documentation searched (classification system followed by classification symbols)
 B29C
 Documentation searched other than minimum documentation to the extent that such documents are included in the fields searched

Electronic data base consulted during the international search (name of data base and, where practicable, search terms used)
 EPO-Internal

C. DOCUMENTS CONSIDERED TO BE RELEVANT

Category*	Citation of document, with indication, where appropriate, of the relevant passages	Relevant to claim No.
X,P	WO 2015/195909 A1 (CARBON3D INC [US]) 23 December 2015 (2015-12-23) Paragraph 8.; pages 31, 32; figure 25	1-15,17
A	WO 2014/126830 A2 (EIPi SYSTEMS INC [US]) 21 August 2014 (2014-08-21) claims 1-28; figures 1,2	1-28

Further documents are listed in the continuation of Box C. See patent family annex.

* Special categories of cited documents :

"A" document defining the general state of the art which is not considered to be of particular relevance	"T" later document published after the international filing date or priority date and not in conflict with the application but cited to understand the principle or theory underlying the invention
"E" earlier application or patent but published on or after the international filing date	"X" document of particular relevance; the claimed invention cannot be considered novel or cannot be considered to involve an inventive step when the document is taken alone
"L" document which may throw doubts on priority claim(s) or which is cited to establish the publication date of another citation or other special reason (as specified)	"Y" document of particular relevance; the claimed invention cannot be considered to involve an inventive step when the document is combined with one or more other such documents, such combination being obvious to a person skilled in the art
"O" document referring to an oral disclosure, use, exhibition or other means	"&" document member of the same patent family
"P" document published prior to the international filing date but later than the priority date claimed	

Date of the actual completion of the international search 20 April 2016	Date of mailing of the international search report 09/05/2016
--	--

Name and mailing address of the ISA/ European Patent Office, P.B. 5818 Patentlaan 2 NL - 2280 HV Rijswijk Tel. (+31-70) 340-2040, Fax: (+31-70) 340-3016	Authorized officer Van Wallene, Allard
--	---

INTERNATIONAL SEARCH REPORT

Information on patent family members

International application No

PCT/US2016/016304

Patent document cited in search report	Publication date	Patent family member(s)	Publication date
WO 2015195909	A1	23-12-2015	NONE

WO 2014126830	A2	21-08-2014	CA 2898098 A1 21-08-2014
		CN 105122136 A	02-12-2015
		EP 2956821 A2	23-12-2015
		JP 2016509962 A	04-04-2016
		KR 20150117274 A	19-10-2015
		WO 2014126830 A2	21-08-2014
