

Feb. 19, 1929.

1,702,964

G. GOUDIS

WALL CONSTRUCTION

Filed Feb. 2, 1927

2 Sheets-Sheet 1

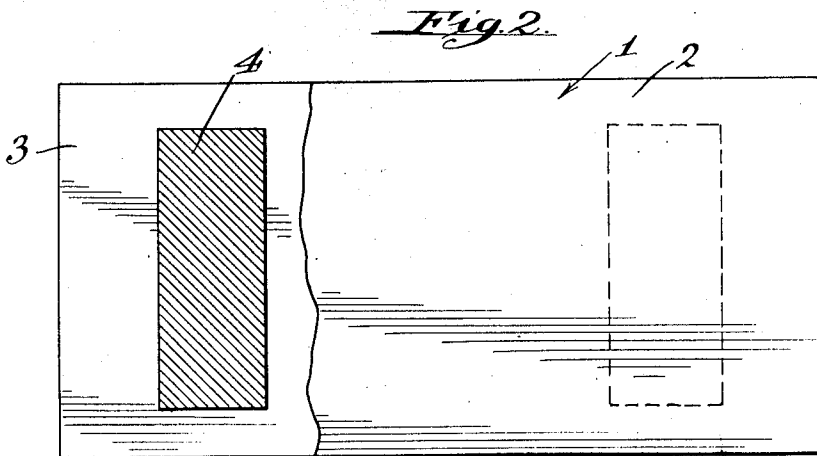
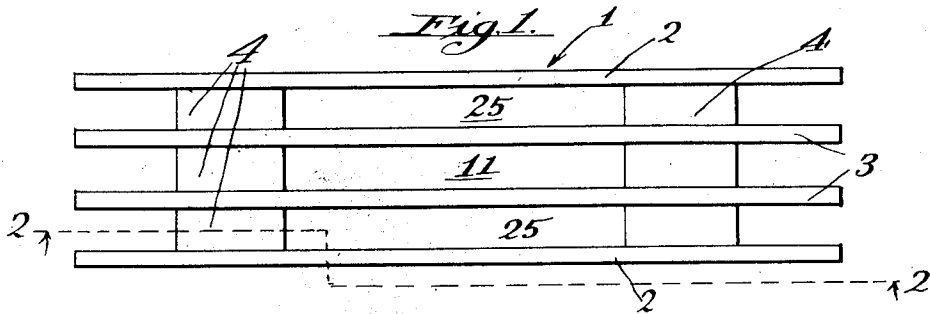
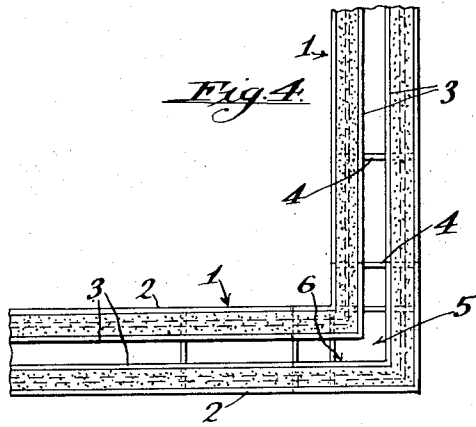
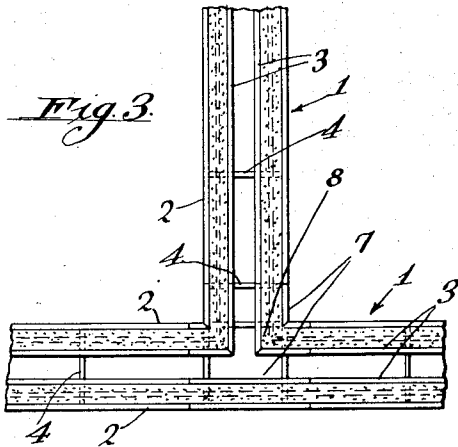

Witness:
[Signature]

Inventor:
George Goudis
by Hazard and Miller
Attorneys

Feb. 19, 1929.

1,702,964

G. GOUDIS

WALL CONSTRUCTION

Filed Feb. 2, 1927

2 Sheets-Sheet 2

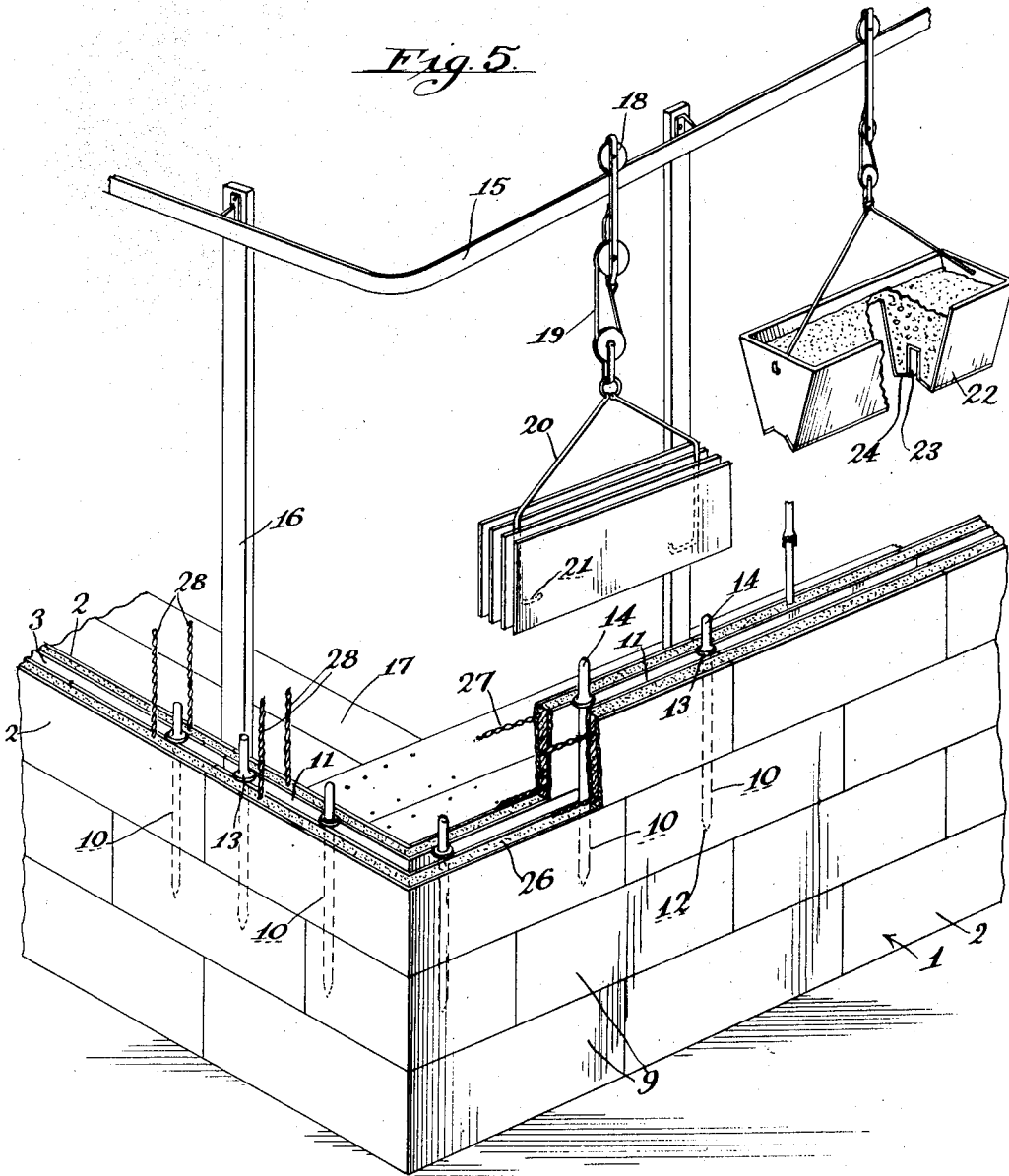

Inventor
George Goudis
by Hazard and Miller
Attorneys

Patented Feb. 19, 1929.

1,702,964

UNITED STATES PATENT OFFICE.

GEORGE GOUDIS, OF LOS ANGELES, CALIFORNIA.

WALL CONSTRUCTION.

Application filed February 2, 1927. Serial No. 165,334.

My invention is in a wall construction and comprises the various units for building up a wall and the method of constructing a wall.

An object of my invention is the construction of walls by using blocks, forming units of construction, these blocks having one or more partitions parallel to the outside or inside faces of the blocks, the blocks being adapted for building up in tiers, and to have a plastic material filled between the partitions, or the partitions and the outer face of the blocks.

Another object of my invention is a wall construction having blocks with outer faces forming the opposite faces, and with a pair of partitions parallel thereto, the partitions and the outer faces being connected together. The blocks are built up in tiers on the wall and concrete or the like is filled between the partitions and the outside faces, leaving a central hollow space.

Another object of my invention is in using the type of blocks above described and having pegs which may be inserted in the central space between two of the inner partitions, these pegs extending downwardly from an upper tier of blocks into a lower tier, and thus centering the blocks. The pegs also form a centering means for a bucket which, with a bottom dumping trap, may discharge concrete between the outer faces and inner partitions.

My invention comprehends both the structure of the blocks, the wall so built up, and the manner or method of constructing.

My invention will be more readily understood from the following description and drawings, in which:

Figure 1 is a plan view of one of the blocks.

Figure 2 is a vertical section taken on the line 2—2 of Fig. 1 in the direction of the arrows.

Figure 3 is a plan of a partly built wall showing a longitudinal wall and a transverse wall joining therewith.

Figure 4 is a plan of a partly built wall showing a corner.

Figure 5 is a perspective view of a wall under construction, showing the manner of building up the blocks, and indicating the method of filling, with the apparatus therefor.

Referring to the construction of the block, as illustrated in Fig. 2, such block is designated generally by the numeral 1 and has outside faces 2, and illustrated as having a pair

of partitions 3. The outside faces and the partitions are joined together by spacer sections 4. The outside faces, the partitions and the spacer sections, are preferably formed integral and may be made of material such as concrete, or of a clay product such as tiles or hollow bricks.

Preferably the blocks are made rectangular, as shown in Figs. 1 and 2, and as these blocks may be readily cut they can be used to make a miter corner, as indicated at 5 in Fig. 4 or, if desired, a certain number of blocks can be cast or molded with a beveled end to be built up into miter blocks 6 to form miter corners. In order to form angles for adjoining walls certain of the blocks may be made into what may be termed angle blocks 7, as indicated in Fig. 3, or a cross wall connection may be made by cutting blocks as indicated by the dotted lines 8 in Fig. 3.

In building a wall, such as shown in Fig. 5, the blocks are built up in tiers 9 starting from the foundation and a series of pegs 10 are inserted in the center space 11 between the two inner partitions. These pegs are preferably pointed at the end 12 and have a shoulder 13 to rest on the upper edge of the two center partitions, these pegs having a projecting hand grip end 14. The pegs are preferably inserted longitudinally of the wall so that they will extend downwardly from the upper tier of blocks to be filled into the central space of a lower tier or tiers of blocks which have already been filled with concrete or other plastic material.

The blocks are preferably handled from an overhead track 15 supported by suitable posts 16, trolleys 18 traveling on the track and having rope 19 operating through pulley 95 blocks with a hook 20 with inturned ends 21 to engage underneath the spacer sections of each block.

When the blocks are properly positioned and centered by the pegs, the concrete is brought to the work in buckets 22 suitably suspended from the track, each of these buckets having a central recess 23 with bottom dumping traps 24 on each side of the recess. The buckets are lowered so that the hand grip end 14 of the pegs fits in the recess of the bucket, thus centering the bucket so that when the traps are tripped the concrete will fill in the outside space 25 between the two outer faces and the partition adjacent each outer face. After a certain amount of concrete has been deposited, horizontal re-

inforcing bars 26 may be inserted in place and then after more concrete has been poured upper reinforcing bars 27 may be inserted extending longitudinally of a tier being filled with concrete. If desired, such reinforcing bars may be suspended in the tier of blocks to be filled in any known manner and vertical reinforcing bars 28 may also be built into the tiers in a vertical direction.

It will thus be seen that I have developed a block for building construction having outside faces with a plurality of partitions parallel thereto, the outside faces and partitions being spaced apart by spacer sections which form a comparatively small section of the blocks considered in a longitudinal direction. It will be noted that these spacer sections are preferably set inwardly from each end of the block and also from the top and lower edges of same. My invention also comprises a wall built up of such blocks with plastic material poured between the outside faces and the partitions next thereto, thus leaving a central hollow or air space.

It is to be understood that the blocks may be varied in shape to suit different types of construction, not only for forming angles or corners but for curved construction and different ornamental features and also that, if desired, the filling of the blocks may be varied so that the center space 10 may be filled in whole or in part, thus constructing the equivalent of solid posts or the like extending vertically. My invention also comprehends the method of constructing the wall, as set forth above.

When cross walls, such as shown in Fig. 3, are built they are constructed at the same time as the outside wall is made up, thus forming an interlocking of the partition and outside walls, giving a monolithic construction.

Referring to Fig. 3, it will be noted that the block connected to the partition has two opposite outside faces which extend at the proper angle to the inside face of the main wall in the direction of the partition wall and that two partition faces also extend inwardly, these being connected to the inner partitions. Thus when the concrete is poured it is molded between the outer face and the partition next thereto of the main wall and also between the inner face and the partition next thereto, this concrete extending into the transverse partition wall.

This invention embodies certain features of my prior application Serial No. 659,889, filed August 29, 1923, for a construction block and method.

Various changes may be made in the principles of my invention without departing from the spirit thereof, as set forth in the description, drawings and claims.

I claim:

1. In a building construction a plurality of

tiers of building blocks, each having an outside layer and a plurality of inner partitions, the partitions being spaced from the layers and from each other by spacer sections, pegs extending downwardly from an upper layer of blocks into a lower layer, said pegs being positioned between two inner partitions, said pegs having a shoulder resting on the upper edge of two of the inner partitions, and a hardening composition between the outer layers and the partitions next thereto, leaving an open space adjacent the pegs.

2. In a building construction, as claimed in claim 1, the said pegs having a hand grip extending above the shoulder, and a bottom dumping bucket having a recess in the bottom, said recess fitting over the handle of the pegs, said bucket having traps to dump a plastic composition into the space between the outer layers and the partition next thereto.

3. The method of wall construction comprising building up a wall with a plurality of blocks, each block having opposite outside faces with a plurality of inner partitions, the partitions being spaced from the outside faces and from each other by spacer sections, inserting pegs downwardly through an upper block into a lower block, said pegs fitting in the space between two inner partitions, centering a filling bucket on the upper ends of said pegs, and discharging a composition into the space between the outer faces and a partition next thereto in the blocks, and removing said pegs.

4. The method of wall construction comprising building a wall with tiers of blocks, each block having opposite outside faces with a plurality of inner partitions, the partitions being spaced from the outer faces and from each other by spacer sections, inserting pegs downwardly in the space between two inner partitions, the pegs being supported on the upper edge of said partitions, filling the space between the outer faces and the partitions next thereto, leaving an open space between the inner partitions, and removing the pegs.

5. The method of wall construction comprising building up a wall with a plurality of blocks, each block having opposite outside faces with a plurality of inner partitions, the partitions being spaced from the outside faces and from each other by spacer sections, said blocks being lifted by engaging the spacer sections, inserting pegs downwardly through an upper block into a lower block, said pegs fitting in the space between two inner partitions, centering a filling bucket on the upper ends of said pegs, and discharging a composition into the space between the outer layers and a partition next thereto in the blocks, and removing said pegs.

In testimony whereof I have signed my name to this specification.

GEORGE GOUDIS.