

CORRECTED VERSION

(19) World Intellectual Property Organization
International Bureau
(43) International Publication Date
16 July 2020 (16.07.2020)



(10) International Publication Number
WO 2020/146509 A9

- (51) International Patent Classification:
G06Q 10/00 (2012.01) G06Q 50/28 (2012.01)
G06Q 10/08 (2012.01) G06Q 50/30 (2012.01)
- (21) International Application Number:
PCT/US2020/012754
- (22) International Filing Date:
08 January 2020 (08.01.2020)
- (25) Filing Language: English
- (26) Publication Language: English
- (30) Priority Data:
62/789,775 08 January 2019 (08.01.2019) US
62/884,351 08 August 2019 (08.08.2019) US
16/543,105 16 August 2019 (16.08.2019) US
16/661,820 23 October 2019 (23.10.2019) US

Christopher; 56 Churchill Avenue, Arlington, MA 02476 (US). **AMEND, John, Richard, Jr.**; 49 Hill Road, Apt. 47, Belmont, MA 02478 (US). **MARONEY, Kyle**; 17 Veterans Way, North Attleboro, MA 02760 (US). **ROMANO, Joseph**; 685 E Taylor Street, San Jose, CA 95112 (US). **HINCHEY, Victoria**; 172 Highland Avenue, Winchester, MA 01890 (US). **KITTREDGE, Jeffrey**; 102 Grove Street, Lexington, MA 02420 (US). **GAUTHIER, Andrew**; 6 Clifton Street, Unit 1, Somerville, MA 02144 (US). **KUMAR, Lakshman**; 130 Middlesex Turnpike, Room 410, Burlington, MA 01803 (US). **VELAGAPUDI, Prasanna**; 5836 Northumberland Street, Pittsburgh, PA 15217 (US).

(74) Agent: **HILTON, William, E.** et al.; Gesmer Updegrave LLP, 40 Broad Street, Boston, MA 02109 (US).

(81) Designated States (unless otherwise indicated, for every kind of national protection available): AE, AG, AL, AM, AO, AT, AU, AZ, BA, BB, BG, BH, BN, BR, BW, BY, BZ, CA, CH, CL, CN, CO, CR, CU, CZ, DE, DJ, DK, DM, DO, DZ, EC, EE, EG, ES, FI, GB, GD, GE, GH, GM, GT, HN, HR, HU, ID, IL, IN, IR, IS, JO, JP, KE, KG, KH, KN, KP, KR, KW, KZ, LA, LC, LK, LR, LS, LU, LY, MA, MD, ME, MG, MK, MN, MW, MX, MY, MZ, NA, NG, NI, NO, NZ, OM, PA, PE, PG, PH, PL, PT, QA, RO, RS, RU, RW, SA,

- (71) Applicant: **BERKSHIRE GREY, INC.** [US/US]; 10 Maguire Road, Building 4, Suite 190, Lexington, MA 02421 (US).
- (72) Inventors: **WAGNER, Thomas**; 97 Alden Road, Concord, MA 01742 (US). **MASON, Matthew, T.**; 3060 Beechwood Boulevard, Pittsburgh, PA 15217 (US). **GEYER,**

(54) Title: SYSTEMS AND METHODS FOR DISTRIBUTING INDUCTION OF OBJECTS TO A PLURALITY OF OBJECT PROCESSING SYSTEMS

(57) Abstract: An induction system is disclosed for filtering the induction of objects to a plurality of object processing systems. The induction system includes an evaluation means for evaluating at least one characteristic of an object, and routing means for routing the object in one of a plurality of directions responsive to the evaluated characteristic, at least one of the plurality of directions leading to a selected one of the plurality of object processing systems.

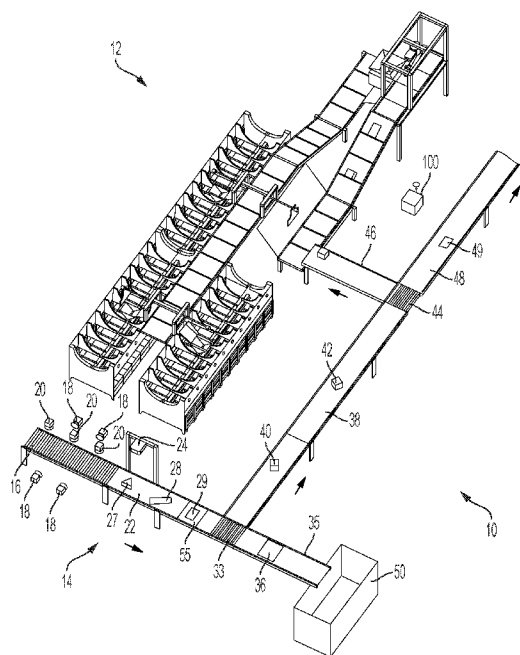

FIG. 1

WO 2020/146509 A9

SC, SD, SE, SG, SK, SL, ST, SV, SY, TH, TJ, TM, TN, TR,
TT, TZ, UA, UG, US, UZ, VC, VN, WS, ZA, ZM, ZW.

- (84) Designated States** (*unless otherwise indicated, for every kind of regional protection available*): ARIPO (BW, GH, GM, KE, LR, LS, MW, MZ, NA, RW, SD, SL, ST, SZ, TZ, UG, ZM, ZW), Eurasian (AM, AZ, BY, KG, KZ, RU, TJ, TM), European (AL, AT, BE, BG, CH, CY, CZ, DE, DK, EE, ES, FI, FR, GB, GR, HR, HU, IE, IS, IT, LT, LU, LV, MC, MK, MT, NL, NO, PL, PT, RO, RS, SE, SI, SK, SM, TR), OAPI (BF, BJ, CF, CG, CI, CM, GA, GN, GQ, GW, KM, ML, MR, NE, SN, TD, TG).

Published:

— *with international search report (Art. 21(3))*

(48) Date of publication of this corrected version:

03 September 2020 (03.09.2020)

(15) Information about Correction:

see Notice of 03 September 2020 (03.09.2020)

SYSTEMS AND METHODS FOR DISTRIBUTING INDUCTION OF OBJECTS TO
A PLURALITY OF OBJECT PROCESSING SYSTEMS

PRIORITY

The present application claims priority to U.S. Provisional Patent Application Ser. No. 62/789,775 filed January 8, 2019; and the present application claims priority to U.S. Patent Application Ser. No. 16/661,820 filed October 23, 2019, which claims priority to U.S. Provisional Patent Application Ser. No. 62/884,351 filed August 8, 2019 and U.S. Provisional Patent Application Ser. No. 62/749,509 filed October 23, 2018; and the present application further claims priority to U.S. Patent Application Ser. No. 16/543,105 filed August 16, 2019, which is a continuation application of U.S. Patent Application Ser. No. 15/956,442 filed April 18, 2018, which claims priority to U.S. Provisional Patent Application Ser. No. 62/486,783 filed April 18, 2017, the disclosures of all of which are hereby incorporated by reference in their entireties.

BACKGROUND

The invention generally relates to automated (e.g., programmable motion) and other processing systems, and relates in particular to programmable motion (e.g., robotic) systems intended for use in environments requiring, for example, that a variety of objects (e.g., articles, parcels or packages) be processed (e.g., sorted and/or otherwise distributed) to several output destinations.

Many object distribution systems receive objects in an organized or disorganized stream that may be provided as individual objects or objects aggregated in groups such as in bags, arriving on any of several different conveyances, commonly a conveyor, a truck, a pallet, a Gaylord, or a bin. Each object must then be distributed to the correct destination container, as determined by identification information associated with the object, which is commonly determined by a label printed on the object. The destination container may take many forms, such as a bag or a bin or a tote.

The processing of such objects has traditionally been done by human workers that scan the objects, e.g., with a hand-held barcode scanner, and then place the objects at assigned locations. For example many order fulfillment operations achieve high efficiency by employing a process called wave picking. In wave picking, orders are picked from warehouse shelves and placed at locations (e.g., into bins) containing multiple orders that are sorted downstream. At

the processing stage individual objects are identified, and multi-object orders are consolidated, for example into a single bin or shelf location, so that they may be packed and then shipped to customers. The processing (e.g., sorting) of these objects has traditionally been done by hand. A human sorter picks an object from an incoming bin, finds a barcode on the object, scans the barcode with a handheld barcode scanner, determines from the scanned barcode the appropriate bin or shelf location for the article, and then places the article in the so-determined bin or shelf location where all objects for that order have been defined to belong. Automated systems for order fulfillment have also been proposed. See for example, U.S. Patent Application Publication No. 2014/0244026, which discloses the use of a robotic arm together with an arcuate structure that is movable to within reach of the robotic arm.

In conventional parcel sortation systems, human workers or automated systems typically retrieve objects in an arrival order, and sort each object into a collection bin based on a set of given heuristics. For instance, all objects of like type might go to a collection bin, or all objects in a single customer order, or all objects destined for the same shipping destination, etc. The human workers or automated systems are required to receive objects and to move each to their assigned collection bin. If the number of different types of input (received) objects is large, a large number of collection bins is required.

Such a system has inherent inefficiencies as well as inflexibilities since the desired goal is to match incoming objects to assigned collection bins. Such systems may require a large number of collection bins (and therefore a large amount of physical space, large capital costs, and large operating costs) in part, because sorting all objects to all destinations at once is not always most efficient.

Certain partially automated sortation systems involve the use of recirculating conveyors and tilt trays, where the tilt trays receive objects by human sortation (human induction), and each tilt tray moves past a scanner. Each object is then scanned and moved to a pre-defined location assigned to the object. The tray then tilts to drop the object into the location. Further, partially automated systems, such as the bomb-bay style recirculating conveyor, involve having trays open doors on the bottom of each tray at the time that the tray is positioned over a predefined chute, and the object is then dropped from the tray into the chute. Again, the objects are scanned while in the tray, which assumes that any identifying code is visible to the scanner.

Such partially automated systems are lacking in key areas. As noted, these conveyors have discrete trays that can be loaded with an object; they then pass through scan tunnels that scan the object and associate it with the tray in which it is riding. When the tray passes the correct bin, a trigger mechanism causes the tray to dump the object into the bin. A drawback

with such systems however, is that every divert requires an actuator, which increases the mechanical complexity and the cost per divert can be very high.

An alternative is to use human labor to increase the number of diverts, or collection bins, available in the system. This decreases system installation costs, but increases the operating costs. Multiple cells may then work in parallel, effectively multiplying throughput linearly while keeping the number of expensive automated diverts at a minimum. Such diverts do not ID an object and cannot divert it to a particular spot, but rather they work with beam breaks or other sensors to seek to ensure that indiscriminate bunches of objects get appropriately diverted. The lower cost of such diverts coupled with the low number of diverts keep the overall system divert cost low.

Unfortunately, these systems don't address the limitations to total number of system bins. The system is simply diverting an equal share of the total objects to each parallel manual cell. Thus each parallel sortation cell must have all the same collection bins designations; otherwise an object might be delivered to a cell that does not have a bin to which that object is mapped. There remains a need for a more efficient and more cost effective object sortation system that sorts objects of a variety of sizes and weights into appropriate collection bins or trays of fixed sizes, yet is efficient in handling objects of such varying sizes and weights.

Further, such systems require human personnel to oversee the induction of objects where the processing system may receive objects that it may not be able to efficiently handle or be able to handle at all.

SUMMARY

In accordance with an aspect, the invention provides an induction system for filtering the induction of objects to a plurality of object processing systems. The induction system includes an evaluation means for evaluating at least one characteristic of an object, and routing means for routing the object in one of a plurality of directions responsive to the evaluated characteristic, at least one of the plurality of directions leading to a selected one of the plurality of object processing systems.

In accordance with another aspect, the invention provides an induction system for filtering the induction of objects to any of a plurality of object processing stations. The induction system includes discrimination means for routing the object in one of a plurality of directions responsive to a discriminating characteristic of the object, at least one of the plurality of directions leading to a selected one of the object processing stations.

In accordance with a further aspect, the invention provides a method of distributing induction of objects to an object processing system including a plurality of object processing stations. The method includes evaluating at least one characteristic of an object, and routing the object in one of a plurality of directions responsive to the evaluated characteristic, at least one of the plurality of directions leading to a selected one of a plurality of object processing stations.

BRIEF DESCRIPTION OF THE DRAWINGS

The following description may be further understood with reference to the accompanying drawings in which:

Figure 1 shows an illustrative diagrammatic view of a processing system and an induction system in accordance with an embodiment of the present invention;

Figure 2 shows an illustrative diagrammatic view of the input station of the induction system of Figure 1;

Figures 3A – 3D show illustrative diagrammatic views of stages of an object moving by perception units at the input station of Figure 2;

Figures 4A – 4D show illustrative diagrammatic side views of stages of the object moving in the input station of Figures 3A – 3D;

Figure 5 shows an illustrative diagrammatic underside view of a perception unit of Figure 1;

Figures 6A – 6C show illustrative diagrammatic views of an object from the perception unit of Figure 5 employing imaging (Figure 6A), edge detection (Figure 6B) and volumetric scanning (Figure 6C);

Figure 7 shows an illustrative diagrammatic view of a label that includes special processing words in accordance with aspect of the system;

Figure 8 shows an illustrative diagrammatic view of a labelled object where the label includes special processing image(s) in accordance with an aspect of the system;

Figure 9 shows an illustrative diagrammatic view of a processing system and an induction system in accordance with another embodiment of the present invention that includes a deformable object induction limiting system;

Figures 10A – 10C show illustrative diagrammatic side views of an object being processed in the deformable object induction limiting system of Figure 9;

Figure 11 shows an illustrative diagrammatic view of a processing system and an induction system in accordance with a further embodiment of the present invention that includes a programmable motion device at the input station;

Figure 12 shows an illustrative diagrammatic view of the input station of the system of Figure 11;

Figure 13 shows an illustrative diagrammatic view of the programmable motion device of the input station of Figures 11 and 12, including additional optional engaged-object perception units (not shown in Figures 11 and 12);

Figure 14 shows an illustrative diagrammatic view of a grasped object with the additional optional engaged-object perception units of Figure 13;

Figure 15 shows an illustrative diagrammatic view of the grasped object of Figure 14 with a set of illumination sources and perception units engaged in accordance with an aspect of the invention;

Figure 16 shows an illustrative diagrammatic side view of the system of Figure 14 showing two sets of perception units;

Figure 17 shows an illustrative diagrammatic side view of the system of Figure 15 showing the two sets of perception units shown in Figure 16;

Figure 18 shows an illustrative diagrammatic view of a 3D scanner system for use in accordance with another aspect of the invention;

Figure 19 shows an illustrative diagrammatic view of a plurality of 3D scanner systems being used in accordance with a further aspect of the invention;

Figure 20 shows an illustrative diagrammatic view of a 3D scan process of an end effector grasping an object;

Figure 21 shows an illustrative diagrammatic view of a net 3D scan of an object and a portion of the end effector that is grasping the object, showing the portion of the 3D scan of the end effector that will be removed;

Figures 22A -- 22D show illustrative diagrammatic views of an object being subjected to deformability testing in accordance with an aspect of the invention;

Figure 23 shows an illustrative diagrammatic view of an object processing system for use with a pre-processing system in accordance with an aspect of the invention;

Figure 24 shows an illustrative diagrammatic side view of the object processing system of Figure 23;

Figure 25 shows an illustrative diagrammatic rear view of the object processing system of Figure 23;

Figure 26 shows an illustrative diagrammatic view of the processing station in the object processing system of Figure 23;

Figure 27 shows an illustrative diagrammatic front view of a primary perception system in the object processing system of Figure 23;

Figures 28A – 28C show an illustrative diagrammatic views of a diverting station in the object processing system of Figure 23 showing an object on a conveyor (Figure 28A), engaged by a diverting paddle (Figure 28B), and discharging the object into a carriage (Figure 28C);

Figure 29 shows an illustrative diagrammatic view of a destination section in the object processing system of Figure 23;

Figure 30 shows an illustrative diagrammatic view of the destination section of Figure 29, with the carriage moved along the track and discharging the object into a destination bin;

Figure 31 shows an illustrative diagrammatic layout model view of an induction system in accordance an aspect of the invention;

Figure 32 shows an illustrative diagrammatic layout model view of another induction system in accordance another aspect of the invention showing a layout similar to the system of Figure 9;

Figure 33 shows an illustrative diagrammatic model view of an induction system in accordance another aspect of the invention that includes a classification system;

Figure 34 shows an illustrative diagrammatic view of an induction system in accordance with an embodiment of the present invention together with a plurality of processing systems;

Figure 35 shows an illustrative diagrammatic view of an induction system in accordance with another embodiment of the present invention together with a plurality of processing systems;

Figure 36 shows an illustrative diagrammatic view of an induction system in accordance with a further embodiment of the present invention together with a plurality of processing systems;

Figure 37 shows an illustrative diagrammatic view of a plurality of induction systems in accordance with an embodiment of the present invention together with a plurality of processing systems;

Figure 38 shows an illustrative diagrammatic view of a plurality of different induction systems in accordance with another embodiment of the present invention together with a plurality of processing systems;

Figures 39A and 39B show illustrative diagrammatic views of a weight sensing conveyor section in accordance with an aspect of the invention that includes a weight scale;

Figures 40A and 40B show illustrative diagrammatic views of a weight sensing conveyor section in accordance with an aspect of the invention that includes load cells or force torque sensors;

Figures 41A – 41D show illustrative diagrammatic views of a weight sensing conveyor section in accordance with an aspect of the invention that further determines a center of mass of an object;

Figures 42A and 42B show illustrative diagrammatic views of a weight sensing conveyor section in accordance with an aspect of the invention that includes multiple scales;

Figures 43A – 43C show illustrative diagrammatic views of a weight sensing conveyor section in accordance with an aspect of the invention that includes multiple rollers with any of load cells or force torque sensors;

Figure 44 shows an illustrative diagrammatic view of an end effector for use in accordance with an aspect of the invention that includes any of load cells or force torque sensors;

Figure 45 shows an illustrative diagrammatic view of an end effector for use in accordance with an aspect of the invention that includes a magnetic sensor;

Figure 46 shows an illustrative diagrammatic view of an end effector for use in accordance with an aspect of the invention that includes vacuum flow and/or pressure sensor;

Figure 47 shows an illustrative diagrammatic view of a weight sensing carriage for use in accordance with an aspect of the invention;

Figure 48 shows an illustrative diagrammatic side view of the weight sensing carriage of Figure 47;

Figure 49 shows an illustrative diagrammatic view of an induction system in accordance with an aspect of the invention that includes a sloping conveyor with a conveyor section that includes bomb-bay drop doors;

Figures 50A and 50B show illustrative diagrammatic views of the conveyor section of Figure 49 over a horizontal conveyor in accordance with an aspect of the invention;

Figures 51A and 51B show illustrative diagrammatic end views of the conveyor section of Figures 50A and 50B;

Figures 52A and 52B show illustrative diagrammatic views of a conveyor section for use in accordance with an aspect of the invention that includes bomb-bay doors over a further sloped conveyor;

Figure 53 shows an illustrative diagrammatic view of an air-permeable conveyor section for use in accordance with an aspect of the invention with a vacuum roller;

Figure 54 shows an illustrative diagrammatic view of an induction system in accordance with an aspect of the present invention that includes an air-permeable conveyor section and a vacuum roller;

Figures 55A – 55D show illustrative diagrammatic side views of the air-permeable conveyor section and vacuum roller of Figure 54 in a system providing sortation by weight;

Figure 56 shows an illustrative diagrammatic view of an induction system in accordance with an aspect of the present invention that includes a conveyor-to-conveyor transfer station;

Figure 57 shows an illustrative diagrammatic view of an air-permeable conveyor section for use in accordance with an aspect of the invention with a blower and a vacuum source;

Figure 58 shows an illustrative diagrammatic side view of the air-permeable conveyor section, blower and vacuum of Figure 57;

Figures 59A – 59C show illustrative diagrammatic side views of the air-permeable conveyor section, blower and vacuum of Figure 57 being used to move an object;

Figure 60 shows an illustrative diagrammatic view of an air-permeable conveyor section for use in accordance with an aspect of the invention with a side blower and a side vacuum source;

Figure 61 shows an illustrative diagrammatic view of an air-permeable conveyor section for use in accordance with an aspect of the invention with a side blower and a side vacuum source, as well as an underside blower source;

Figure 62 shows an illustrative diagrammatic view of a conveyor section for use in accordance with an aspect of the invention with a side blower and a side vacuum source;

Figure 63 shows an illustrative diagrammatic view of the conveyor section, side blower and side vacuum source of Figure 62 for use in accordance with an aspect of the invention with opposing chutes;

Figure 64 shows an illustrative diagrammatic side view of the conveyor section, side blower, side vacuum source and opposing chutes of Figure 63;

Figure 65 shows an illustrative diagrammatic view of a conveyor section for use in accordance with an aspect of the invention that includes bi-directional rollers and a pair of opposing chutes;

Figures 66A and 66B show illustrative diagrammatic views of a conveyor section for use in accordance with an aspect of the invention that includes bi-directional rollers and a pair of opposing chutes with bomb-bay doors;

Figure 67 shows an illustrative diagrammatic view of a conveyor section for use in accordance with an aspect of the invention that includes a side blower and a side vacuum source, and a pair of opposing chutes with bomb-bay doors;

Figures 68A and 68B show illustrative diagrammatic views of a conveyor section for use in accordance with an aspect of the invention with side paddles and a pair of opposing chutes;

Figure 69 shows an illustrative diagrammatic view of a conveyor section for use in accordance with an aspect of the invention with side paddles and opposing chutes, one of which includes bomb-bay doors;

Figure 70 shows an illustrative diagrammatic view of multiple processing systems for use with an induction system as disclosed with reference to Figures 1, 9, 11, 34 – 38, 49, 54, 56 and 63 – 69 employing manual and automated processing stations;

Figure 71 shows an illustrative diagrammatic view of an object processing system for use with induction systems employing automated carriers as disclosed with reference to Figures 63 – 69 and an automated processing station;

Figure 72 shows an illustrative diagrammatic view of an object processing system for use with induction systems employing automated carriers as disclosed with reference to Figures 63 – 69 and a manual processing station; and

Figure 73 shows an illustrative diagrammatic view of an object processing system for use with an induction system employing automated carriers as disclosed with reference to Figures 63 – 69 that includes both manual and automated processing stations.

The drawings are shown for illustrative purposes only.

DETAILED DESCRIPTION

In accordance with an embodiment, the invention provides an induction filtering system in which objects (e.g., packages) are screened and limited from entering an object processing system. Only objects that meet defined criteria may be processed by the object processing system in accordance with certain aspects of the invention. The induction filtering system includes at least one evaluation system as well as multiple processing paths, at least one of which leads to the object processing system in accordance with certain aspects of the invention.

An automated package sortation system needs to be able to singulate and sort individual packages, in order to route them to specific destinations. Some package sortation systems handle packages using a robotic picking system. The robot acquires a grip on the package, separating it from a pile of other packages, where it can then be scanned and sent to a sorting location. Such

automated package handling systems inevitably encounter packages that cannot be processed, because, for example, the packages are outside of the system's package specifications. The robot or the gripper, for example, can only pick items that are within a weight specification. Thus items that it cannot handle might include items that are too light or too heavy, that are too big or too small, or that in some other way cannot be handled by the system.

These incompatible packages can jam up the system. If they are too big, they may get stuck on the conveying systems through the robot package sortation system, and therefore prevent other packages from flowing through. The incompatible packages may also reduce the effective throughput of the sortation system. If they do get through and are presented in a pile to the robot picking system, then the robot may try to pick the incompatible packages. If the package is outside of the system's specification, then the resulting grip on the object might be inadequate to safely transfer the item, and the robot might drop the package and potentially damage the package. Alternatively, if it is able to successfully pick and transfer the package, in doing so it could potentially damage the robotic picking system in some way while straining to move the out-of-specification package.

Compatible package specifications might include: a range of valid package weights, a range of compatible package dimensions, a set of valid labeling types (e.g., whether they employ a printed-on label vs. an adhesive-applied label), exclusion of items marked as fragile, exclusion of items marked as having been insured at high value, and therefore would prefer to be sorted with greater care by hand, exclusion of items marked as containing hazardous materials, such as lithium-ion batteries, and exclusion for any other reason for which the package might be flagged in a database as requiring exception or manual handling. It is desired to provide a system that filters out incompatible packages before they arrive at the package handling system, and/or improves the ability of the package handling system to specifically recognize incompatible packages so that robotic picks are not attempted on objects needing to be handled manually.

In accordance with an embodiment, the invention provides an induction system that limits or manages the induction of objects to an object processing system. In certain aspects, the system provides a variety of approaches to automatically re-route incompatible packages before they arrive at a package sortation system consisting of one or more robotic pickers, or to minimize their impact should they arrive at a robotic picking area.

Figure 1, for example, shows an induction system 10 that filters (e.g., limits, or manages) objects that are being fed to an object processing system 12. The induction system 10 includes an input station 14 to which objects are presented, for example, in a singulated stream on a conveyor 22. Any of the conveyors of the systems of Figures 1, 9, 11, 23, 34 – 38, 49, 56 and

70 may be cleated or non-cleated conveyors, and the systems may monitor movement of the conveyors (and thereby the objects thereon) via a plurality of sensors and/or conveyor speed control systems. A response evaluation section 16 of the conveyor 22 includes one or more transport sets of rollers 30, as well as one or more perturbation rollers 32 as shown in Figure 2. With further reference to Figures 3A – 3D, perception units (e.g., cameras or scanners) 18 are directed horizontally toward the conveyor section 16, and perception units (e.g., cameras or scanners) 20 are directed downward onto the conveyor section 16.

With reference to Figures 4A – 4D, when an object 34 travels along the transport rollers 30, it will contact a perturbation roller 32 (as shown in Figure 4B). The perturbation roller(s) 32 may be any of a larger diameter roller, or may be raised with respect to the transport rollers 30, and may be rotating at a faster rotational velocity than the transport rollers 30. In this way, and using the perception units 18, 20, the system may determine (together with computer processing system 100) a wide variety of characteristics of the object 34. For example, the rollers 32 may be mounted on force torque sensors (as discussed further below with reference to Figures 40A – 42C), and the system may determine an estimated weight when the object 34 is determined (using the perception units 18) to be balanced on the roller 32. The roller(s) 32 on force torque sensors may therefore be used to determine an object's weight as it passes over the roller(s).

Further, if the roller(s) 32 are rotating at a faster rotational velocity, the system may determine an inertial value for the object 34 as the roller(s) engage and discharge the object from the roller(s). A wide variety of further characteristics may also be determined or estimated, such as for example, center of mass (COM) using the roller(s) in combination with the perception unit(s) as discussed herein and further below. The system may further use the perception units and roller(s) 32 (together with computer processing system 100) to determine whether the object is a collapsible bag, and/or whether the presumed object 34 is actually a multi-pick (includes multiple objects), again, using the perception unit(s) in combination with the roller(s) by observing whether the objects move apart and/or whether the shape of the object changes as it rides over the roller(s) 32. In accordance with further aspects of the invention, the transport rollers 30 may be replaced by conveyor sections that stand below the height of the perturbation rollers 32.

The induction system 10 may further include a multi-purpose perception unit 24 positioned above the conveyor 22 (e.g., higher above than units 20) for viewing an object 27 as shown in Figure 1. The perception unit 24 includes lights 74 as well as one or more perception units 76 (e.g., scanners or cameras) for detecting any identifying indicia (e.g., barcode, QR code, RFID, labels etc.) on objects on the conveyor 22.

The perception unit 24 also includes scanning and receiving units 80, 82, as well as edge detection units 84 for capturing a variety of characteristics of a selected object on the conveyor 22. Figure 6A shows a view from the capture system, and knowing the recorded volume of the view of an empty conveyor 22, the volume of the object 27, V_{27} may be estimated. In particular, the object 27 is volumetrically scanned as shown in Figure 6C. This volume is compared with recorded data regarding the item that is identified by the identifying indicia as provided by the perception units 18, 20 or the recorded object data.

In accordance with further aspects of the invention, the system may additionally employ edge detection sensors 84 that are employed (again together with the processing system 100), to detect edges of any objects in a bin, for example using data regarding any of intensity, shadow detection, or echo detection etc., and may be employed for example, to determine any of size, shape and/or contours as shown in Figure 6B.

The volumetric scanning may be done using the scanning unit 80 and receiving unit 82 (together with the processing system 100 shown in Figure 1), that send and receive signals, e.g., infrared signals. With reference to Figure 6C, the volumetric data may be obtained for example, using any of light detection and ranging (LIDAR) scanners, pulsed time of flight cameras, continuous wave time of flight cameras, structured light cameras, or passive stereo cameras.

As discussed in more detail below with reference to Figures 39A – 43C, an object's weight may also be determined using weight sensing conveyor sections. For example, weight sensing conveyor section 55 of Figure 1 may be used to determine a weight (again, as discussed below) of an object 8. As an object is fed through the input station, the object will pass through the response evaluation section 16 and multi-purpose perception unit 24 (e.g., object 28), and may then be evaluated by the weight sensing conveyor section.

With reference again to Figure 1, the induction system 10 may provide that unidentified objects (as well as objects identified as not being appropriate for processing) 36 are passed through to a conveyor 35 to an exception bin 50. If an object (e.g., 40, 42) is identified as being appropriate for processing, the object is diverted by multi-directional conveyor 33 toward conveyor 38. Conveyor 38 may direct the object(s) toward an infeed conveyor 46 via multi-directional conveyor 44, or the system may determine that that the object (e.g., object 49) should be directed along conveyor 48 toward any of additional processing stations (e.g., similar to processing station 12 but able to handle different types of objects). For example, and as discussed in more detail below, the system may employ multiple processing stations, each able to handle different objects (such as different size or weight ranges of objects).

In accordance with yet further aspects of the invention, the system may employ optical character recognition (OCR) to read labels and detect, for example, trigger words such as “paint” or “hazardous” or “hazardous?: Y” or “Fragile” as shown at 110 in Figure 7. In further aspects, the system may identify images, such as trigger images as shown at 112 in Figure 8, indicating that the contents are flammable, are required to remain upright, or are otherwise hazardous or require specialized handling, making them not suitable for processing by the object processing system 12. The use of such processes permits the detection of objects that are incompatible with the processing system because of their contents as indicated by trigger indicia on an external label. This may involve reading labels as noted above and either not picking the object or moving the object to an exception processing area, or may involve simply identifying the object. For example, if the system includes an object database, the system may recognize indicia (such as a bar code), and then look up information regarding the scanned code (such as that the object contains hazardous material or otherwise needs special processing. In this case, the system will route the object toward an exception area.

Figure 9 shows an induction system 11 that may provide selected objects to the object processing system 12. The induction system 11 includes an input station 14 as discussed above with reference to Figures 1 – 8 that includes a conveyor 22 (with a response evaluation section 16 including transport rollers 30, perturbation rollers 32, and perception units 18, 20), as well as multipurpose perception unit 24, and weighing conveyor 55 for evaluating objects 34, 27, 28 and 29 as discussed above. Again, the system may, for example, determine which of the infeed objects are provided as bags by observing the object as it passes over a perturbation roller(s) using the perception unit(s), and in particular, observing the rate or amount of change in speed and/or the shape of the object as the object is processed.

In the induction system of Figure 9, when each object arrives at an infeed multi-directional routing conveyor 132, the object is any of: routed to an out-of-specification conveyor 134 (e.g., object 136), routed to an in-specification conveyor 138 (e.g., objects 140, 142), or routed to bag-processing conveyor 144 (e.g., objects 146, 151, 153). When objects are provided as bags, for example, shipping bags made from polyethylene, it may be more difficult to determine an object’s size or other handling parameters. If an object is identified as being a bag (or other flexible, malleable object), such objects (again, e.g., 146, 148, 151, 153) are diverted to a bag-processing system.

In particular, the conveyor 144 leads to a deformable object induction limiting system 194 that includes a programmable motion device such as an articulated arm 192 having an end effector 193 with a load cell or force torque sensor 195 (shown in Figures 10A – 10C). In

particular, the system will move the end effector 193 with the object 191 into contact with an opening formed by sloped walls 133. If the load cell or force torque sensor 195 detects too much force it (above a sensor threshold) when the object contacts the sloped walls 133, then the system may reject the object for processing. The object would then be placed on a conveyor 196, which joins conveyor 134, leading to an area for objects that are not to be processing by the system 12, such as, for example a collection bin or a manual processing station.. The system may thereby limit the acceptance of objects that are deformable but still too rigid for processing by the system 12. Load cells or force torque sensors 135 may also be provided on the sloped walls as shown at 133 instead of or together with the use of the load cell or force torque sensor 195, or at the base of the sloped walls as shown at 135. If, on the other hand, movement of the object 191 into the opening provided by the sloped walls 133 does not trigger any load cell or force torque sensor above a threshold, then the system may move the object 191 to a conveyor 198 that leads to the processing system 12.

If the object 191 is determined to be insufficiently flexible for processing by the object processing system 12 (again with reference to Figure 9), the object may be placed by the articulated arm 192 onto an out-of-specification conveyor 196 (that may join with conveyor 134). If the object 191 is determined to be sufficiently flexible for processing by the object processing system (or another system coupled thereto as discussed in more detail below), the object 191 is placed by the articulated arm 192 onto conveyor 198 that leads to a bi-directional conveyor 45. If the object is to be processed by object processing system 12, then the object is directed toward conveyor 19, and if the object is to be processed by a further object processing system (as discussed below for example with reference to Figure 36), the object (e.g., 43) is directed toward a further conveyor 47. Again, the operation is controlled by one or more computer processing systems 200.

Figure 11 for example, shows a further induction system 13 in accordance with an embodiment of the present invention that limits or manages packages that are being fed to an object processing system 12. The induction system 13 includes an input station 114 that includes an induction input programmable motion device, such as an articulated arm 116 and end effector 118 (shown in Figures 12 and 13) that are designed to be able to grasp and move a wide variety of objects. In particular, the articulated arm 116 may be designed to grasp and move objects that are, for example, too large or too heavy to be handled by the processing system 12, as well as objects that the processing system 12 is designed to handle. Objects (either individually or in bins 120) are provided on an infeed conveyor 122 to the articulated arm 116. Any of a variety

of detection units 117 may also be positioned around and directed toward the end effector 118 of the articulated arm 116 as discussed further below.

The input system may, for example, determine which of the infeed objects are provided as bags by observing the object as it is held by the end effector 118 as discussed further below with reference to Figures 22A – 22D. In the induction system of Figure 11, when each object (e.g., object 128 on conveyor 130 or object 129 on weight sensing conveyor section 155) arrives at an infeed multi-directional routing conveyor 132, the object is any of: routed to an out-of-specification conveyor 134 (e.g., object 136), routed to an in-specification conveyor 138 (e.g., objects 140, 142), or routed to bag-processing conveyor 144 (e.g., objects 146, 151, 153) as discussed above with reference to Figure 9. When objects are provided as bags, for example, shipping bags made from polyethylene, it may be more difficult to determine an object's size or other handling parameters. If an object is identified as being a bag (or other flexible, malleable object), such objects (again, e.g., 146, 148, 151, 153) are diverted to a bag-processing system.

Again, the conveyor 144 leads to a deformable object induction limiting system 194 that includes a programmable motion device such as an articulated arm 192 having an end effector with a load cell or force torque sensor (as discussed above with reference to Figures 10A – 10C). The system will move the end effector with the object into contact with an opening formed by sloped walls. If the load cell or force torque sensor detects too much force it (above a sensor threshold) when the object contacts the sloped walls, then the system may reject the object for processing. The object would then be placed on a conveyor 196, which joins conveyor 134, leading to an area for objects that are not to be processing by the system 12. Again, the conveyor 134 may, for example, lead to a collection bin or a manual processing station. The system may thereby limit the acceptance of objects that are deformable but still too rigid for processing by the system 12. Load cells or force torque sensors may also be provided on the sloped walls instead of or together with the use of the load cell or force torque sensor, or at the base of the sloped walls. If, on the other hand, movement of the object into the opening provided by the sloped walls does not trigger any load cell or force torque sensor above a threshold, then the system may move the object to a conveyor 198 that leads to the processing system 12.

If the object is determined to be insufficiently flexible for processing by the object processing system 12, the object may be placed by the articulated arm 192 onto an out-of-specification conveyor 196 (again, that may join with conveyor 134). If the object is determined to be sufficiently flexible for processing by the object processing system (or another system coupled thereto as discussed in more detail below), the object is placed by the articulated arm 192 onto conveyor 198 that leads to a bi-directional conveyor 59. If the object is to be processed

by object processing system 12, then the object is directed toward conveyor 51, and if the object is to be processed by a further object processing system (as discussed below for example with reference to Figure 37), the object (e.g., 53) is directed toward a further conveyor 57. Again, the operation is controlled by one or more computer processing systems 200.

With reference to Figures 12 and 13, a perception system 124 captures perception data regarding the objects (whether or not in bins 120) that are below the perception system 124. Objects 128 are identified by the perception system 124, then grasped and are placed on routing conveyor 130. Emptied bins 120 are routed along an empty bin conveyor 126. The placement location of the objects on the conveyor 130 is noted (and again each of the conveyors may be a cleated conveyor). With reference to Figure 11, when each object arrives at an infeed-diverter 132, the object is either: routed to an out-of-specifications conveyor 134 (e.g., object 136), routed to an in-specifications conveyor 138 (e.g., objects 140, 142), or routed to bag-processing conveyor 144 (e.g., objects 146, 148, 151, 153). The conveyor 130 may also include a weight sensing conveyor section 155 for determining the weight of objects 129 as discussed below with reference to Figures 39A – 43C. The end effector 118 may further include a force torque sensor 154 for determining a weight of an object being held by the end effector 118 as discussed further below with reference to Figures 44 and 45 and/or an internal air pressure and/or air flow sensor as discussed further below with reference to Figure 46.

Again, when objects are provided as bags, for example, shipping bags made from, e.g., polyethylene, it may be more difficult to determine an object's size and handling parameters. If an object is identified as a bag (or other flexible, malleable object), such objects (again e.g., 146, 148, 151, 153) are diverted to a bag-processing system as discussed further above. The end effector 118 may also include a load cell or force torque sensor 154 (as discussed in more detail below with reference to Figures 44 and 45) for determining a weight of an object being grasped, and in further aspects, the conveyor 30 may include a weighing section 155 (again, as discussed below with reference to Figures 39A – 43C), at which each object may be weighed.

In accordance with further aspects, the system may estimate a volume of an object while the object is being held by the end effector. In particular, the system may estimate a volume of picked item while being held by gripper, and compare the estimated volume with a known volume. One approach is to estimate the volume of the one or more items while the gripper is holding the object 197 (or objects). With reference to Figures 14 and 15, in such as a system 150, one or more perception units 152, 154, 156, 158 (e.g., cameras or 3D scanners) are placed around a scanning volume. With further reference to Figures 16 and 17, opposite each perception

unit is an illumination source 162, 164, 166, 168 as well as a diffusing screen 172, 174, 176, 178 in front of each illumination source.

As shown in Figure 17, perception data regarding the object 197 as backlit by the illumination source (e.g., 168) and diffuser (e.g., 178) will be captured by each perception unit (e.g., 158). In accordance with various aspects, three perception units may be used, spaced apart by one hundred twenty degrees, and in accordance with further aspects, fewer perception units may be used (e.g., one or two), and the object may be rotated between data acquisition captures.

The scanning volume may be the volume above the area where the items are picked from; or the scanning volume may be strategically placed in between the picking location and the placing location to minimize travel time. Within the scanning volume, the system takes a snapshot of the volume of items held by the gripper. The volume could be estimated in a variety of ways depending on the sensor type as discussed above.

For example, if the sensors are cameras, then two or more cameras may be placed in a ring around the volume, directed slightly upward towards a backlighting screen (as discussed above) that may be in the shape of sections of a torus, where the gripped volume is held in between all the cameras and the brightly lit white screen. The brightly lit screen backlights the one or more held objects, so that the interior volume is black. Each perception unit and associated illumination source may be activated in a sequence so that no two illumination sources are on at the same time. This allows easy segmentation of the held volume in the image.

The illumination may be provided as a particular wavelength that is not present in the room, or the illumination may be modulated and the detector may demodulate the received perception data so that only illumination from the associated source is provided. The black region once projected back into space, becomes a frustum and the objects are known to lie within a solid frustum. Each camera generates a separate frustum, with the property that the volume of the items is a subset of all of the frustums. The intersection of all the frustums yields an upper bound on the volume of the object(s). The addition of a camera improves the accuracy of the volume estimate. The gripper may be visible within the cameras, and because its position is known, its volume can be subtracted out of the frustum or volume estimate.

In accordance with other aspects, 3D scanners may be used that obtain 3D images of the scanning volume, then the volume estimates are obtained in a similar way by fusing together the point clouds received from each sensor, but without the need for segmenting the images from the background using backlighting. Each 3D scanner returns a 3D image, which for each pixel in the image returns a depth, and again, may use any of light detection and ranging (LIDAR) scanners,

pulsed time of flight cameras, continuous wave time of flight cameras, structured light cameras, or passive stereo cameras, etc.

Figure 18, for example, shows a 3D scanner 182 that projects a grid 188 onto a field of view. The 3D scanner 182 may be used in a system 180 as shown in Figure 19 together with one, two, or three other 3D scanners (two others are shown at 184, 186). The 3D scanners are directed toward a common volume in which the object 197 is positioned while attached to the end effector 118. Again, with three such 3D scanners, the scanners may be positioned one hundred twenty degrees apart (ninety degrees apart if four are used, and opposing each other if only two are used). With reference to Figures 20 and 21, each 3D scanner (e.g., 182) captures 3D data regarding the object 197. Again, the volume of the end effector may be removed from the captured data.

In accordance with further aspects, the system may detect changes in object shape when an object is jostled. This may be done when an object is first lifted (for example at the input station 114 in Figure 11 and/or at the deformable object induction limiting system 194 in Figures 9 and 11). With reference to Figures 22A – 22D, when an object (e.g., 145) is lifted from a bin or conveyor by the end effector 118, the object 145 may be held as shown in Figure 22B, and then subjected to a quick shake motion as shown in Figures 22C and 22D. If the shape of the object changes (beyond, for example, 2%, 5% or 10%), then the object may be classified as being a deformable object such as a polyethylene shipping bag. The scanning may be done by any of the above discussed volumetric scanning, edge detection, LIDAR, and camera image analysis systems. If the object is determined to be a deformable object, it is routed to the conveyor 44 as discussed above.

Again, the conveyor 144 leads to a deformable object induction limiting system 194. The deformable object induction limiting system 194 includes a programmable motion device such as an articulated arm 192 having an end effector 193 with a load cell or force torque sensor 195 (shown in Figures 10A – 10C). In particular, the system will move the end effector 193 with the object into contact with an opening formed by sloped walls 133. If the load cell or force torque sensor 195 detects too much force it (above a sensor threshold) when the object contacts the sloped walls 133, then the system may reject the object for processing. The object would then be placed on a conveyor 196, which joins conveyor 134, leading to an area for objects that are not to be processed by the system 12. The system may thereby limit the acceptance of objects that are deformable but still too rigid for processing by the system 12. Load cells or force torque sensors may also be provided on the sloped walls as shown at 133 instead of or together with the use of the load cell or force torque sensor 195, or at the base of the sloped walls as shown at 135.

If, on the other hand, movement of the object 145 into the opening provided by the sloped walls 133 does not trigger any load cell or force torque sensor above a threshold, then the system may move the object 145 to a conveyor 198 that leads to the processing system 12.

The processing system 12, for example, may include an infeed area 201 into which objects may be provided by the processing infeed conveyor (e.g., 46, 19, 51). An infeed conveyor 202 conveys objects from the infeed area 201 to an intermediate conveyor 204 at a processing station 206. The infeed conveyor 202 may include cleats for assisting in lifting the objects from the input area 200 onto the intermediate conveyor 204.

The processing station 206 also includes a grasp perception system 208 that views the objects on the intermediate conveyor 204, and identifies grasp locations on the objects as further shown in Figure 23. The processing station 206 also includes a programmable motion device 210, such as an articulated arm, and a primary perception system 212 such as a drop perception unit. The grasp perception system 212 surveys the objects to identify objects when possible, and to determine good grasp points. The object is then grasped by the device 210, and dropped into the drop perception system 212 to ensure that the object is accurately identified. The object then falls through the primary perception system 212 onto a primary transport system 214, e.g., a conveyor. The primary transport system 214 carries the objects past one or more diverters 216, 218 that may be engaged to divert an object off of the primary transport system 214 into any of carriages 220, 222, 224 (when the respective carriage is aligned with the diverter) or into the input area 200. Each of the carriages 220, 222, 224 is reciprocally movable along a track the runs between rows of destination stations 226 of shuttle sections 228 (as discussed below in more detail).

The flow of objects is diagrammatically shown in Figure 24, which shows that objects move from the infeed area 201 to the intermediate conveyor 204. The programmable motion device 210 drops the objects into the drop perception unit 212, and the objects then land on the primary transport system 214. The objects are then conveyed by the primary transport system 214 to diverters that selectively divert objects to carriages (e.g., 220, 222, 224). The carriages bring the objects to one of a plurality of destination stations 226 (e.g., a processing box or a processing bin) and drops the object into the appropriate destination station. When a destination station is full or otherwise complete, the destination station is moved to an output conveyor.

Figure 25 shows a rear view of the system of Figure 23 that more clearly shows the programmable motion device and the drop perception system. The primary transport system 214 may be a cleated conveyor and the objects may be dropped onto the cleated conveyor such that one object is provided per cleated section. The speeds of the conveyors 202 and 214 may also

be controlled to assist in providing a singulated stream of objects to the diverters 216, 218. The system may operate using a computer processing control system 200 that communicates with the conveyor control systems, the perception units, the programmable motion devices, the diverters, the box or bin removal systems, and any and all sensors that may be provided in the system.

With reference to Figure 26, the processing station 206 includes a grasp perception system 208 that is mounted above the intermediate conveyor 204, which provides objects to be processed. The grasp perception system 208, for example, may include (on the underside thereof), a camera, a depth sensor and lights. A combination of 2D and 3D (depth) data is acquired. The depth sensor may provide depth information that may be used together with the camera image data to determine depth information regarding the various objects in view. The lights may be used to remove shadows and to facilitate the identification of edges of objects, and may be all on during use, or may be illuminated in accordance with a desired sequence to assist in object identification. The system uses this imagery and a variety of algorithms to generate a set of candidate grasp locations for the objects in the bin as discussed in more detail below.

The programmable motion device 210 may include a robotic arm equipped with sensors and computing, that when combined is assumed herein to exhibit the following capabilities: (a) it is able to pick objects up from a singulated stream of objects using, for example, an end effector; (b) it is able to move the object to arbitrary places within its workspace; and, (c) it is able to generate a map of objects that it is able to pick, represented as a candidate set of grasp points in the workcell, and as a list of polytopes enclosing the object in space. The allowable objects are determined by the capabilities of the robotic system. Their size, weight and geometry are assumed to be such that the robotic system is able to pick, move and place them. These may be any kind of ordered goods, packages, parcels, or other articles that benefit from automated processing.

The correct processing destination is determined from the symbol (e.g., barcode) on the object. It is assumed that the objects are marked in one or more places on their exterior with a visually distinctive mark such as a barcode or radio-frequency identification (RFID) tag so that they may be identified with a scanner. The type of marking depends on the type of scanning system used, but may include 1D or 2D barcode symbologies. Multiple symbologies or labeling approaches may be employed. The types of scanners employed are assumed to be compatible with the marking approach. The marking, either by barcode, RFID tag, or other means, encodes a *symbol string*, which is typically a string of letters and numbers, which identify the object.

Once grasped, the object may be moved by the programmable motion device 210 to a primary perception system 212 (such as a drop scanner). The object may even be dropped into

the perception system 212. In further aspects, if a sufficiently singulated stream of objects is provided on the intermediate conveyor 204, the programmable motion device may be provided as a diverter (e.g., a push or pull bar) that diverts object off of the intermediate conveyor into the drop scanner. Additionally, the movement speed and direction of the intermediate conveyor 204 (as well as the movement and speed of infeed conveyor 202) may be controlled to further facilitate providing a singulated stream of objects on the intermediate conveyor 204 adjacent the drop scanner.

As further shown in Figure 27, the primary perception system 212 may include a structure 234 having a top opening 236 and a bottom opening 238, and may be covered by an enclosing material 240. The structure 234 includes a plurality of sources (e.g., illumination sources such as LEDs) 242 as well as a plurality of image perception units (e.g., cameras) 244. The sources 242 may be provided in a variety of arrangements, and each may be directed toward the center of the opening. The perception units 244 are also generally directed toward the opening, although some cameras are directed horizontally, while others are directed upward, and some are directed downward. The system 212 also includes an entry source (e.g., infrared source) 246 as well as an entry detector (e.g., infrared detector) 247 for detecting when an object has entered the perception system 212. The LEDs and cameras therefore encircle the inside of the structure 234, and the cameras are positioned to view the interior via windows that may include a glass or plastic covering (e.g., 248).

In accordance with certain aspects, the invention provides the ability to identify via barcode or other visual markings of objects by employing a perception system into which objects may be dropped. Automated scanning systems would be unable to see barcodes on objects that are presented in a way that their barcodes are not exposed or visible. The system 212 therefore is designed to view an object from a large number of different views very quickly, reducing or eliminating the possibility of the system 212 not being able to view identifying indicia on an object.

Following detection by the perception unit 212, the object is now positively identified and drops onto the primary transport system 214 (e.g., a conveyor). With reference again to Figures 23 and 25, the primary transport system 214 moves the identified object toward diverters 216, 218 that are selectively engageable to divert the object off of the conveyor into any of carriages 220, 222, 224 or (if the object was not able to be identified), the object may be either returned to the input area 200 or it may be dropped off of the end of the conveyor 214 into a manual processing bin. Each carriage 220, 224, 226 is reciprocally movable among destination bins 230 of one of a plurality of destination sections 228. Efficiencies in space may be provided

in accordance with certain aspects by having objects first move from the input area 201 along the infeed conveyor 202 in a direction that has a horizontal component and a vertical component. The object then drops through the drop scanner 212 (vertically) and lands on the primary transport conveyor 214, which also moves the object in a direction that has a horizontal component (opposite in direction to that of the infeed conveyor 202) and a vertical component. The object is then moved horizontally by a carriage 220, 222, 224, and dropped (vertically) above a target destination station 230, such as a destination bin.

With reference to Figures 28A – 28C, a diverter unit (e.g., 216) may be actuated to urge an object (e.g., 250) off of the conveyor 214 into a selected carriage (e.g., 220) that runs along a rail 221 between destination locations (stations) 230. The diverter unit may include a pair of paddles 223 that are suspended by a frame 225 that provide that the paddles are actuatable linearly to move an object 250 off of the conveyor in either direction transverse to the conveyor. Again, with reference to Figure 18, one direction of diversion for diverter 216, is to return an object to the infeed area 201.

Systems of various embodiments provide numerous advantages because of the inherent dynamic flexibility. The flexible correspondence between sorter outputs and destinations provides that there may be fewer sorter outputs than destinations, so the entire system may require less space. The flexible correspondence between sorter outputs and destinations also provides that the system may choose the most efficient order in which to handle objects, in a way that varies with the particular mix of objects and downstream demand. The system is also easily scalable, by adding sorters, and more robust since the failure of a single sorter might be handled dynamically without even stopping the system. It should be possible for sorters to exercise discretion in the order of objects, favoring objects that need to be handled quickly, or favoring objects for which the given sorter may have a specialized gripper.

Figure 29 shows a destination section (e.g., such as any of sections 228 of the system 12) that includes a movable carriage (e.g., 220) that may receive an object 252 from the end effector of the programmable motion device. The movable carriage 220 is reciprocally movable between two rows of the destination bins 230 along a guide track 221. As shown in Figure 29, each destination bin 230 includes a guide chute that guides an object dropped therein into the underlying destination bin 230. The carriage 220 moves along a track 221, and the carriage may be actuated to drop an object 252 into a desired destination bin 230 via the guide chute (as shown in Figure 30).

The movable carriage is therefore reciprocally movable between the destination bins, and the/each carriage moves along a track, and may be actuated to drop an object (e.g., 252) into a desired destination bin. In certain aspects, the carriage (e.g., 220) may include sensors (e.g., transmitter and receiver pairs 260 and/or 262 that may be used to confirm that an object has been received by the carriage or confirming that an object has been discharged by the carriage. In still further aspects, the carriage may be mounted onto a rail chassis via load cells 264 such that the weight within the carriage may be determined from load cell output sensor data as discussed further below with reference to Figures 47 and 48. Knowledge of the weight in the carriage may be used to confirm that an object has been received by the carriage, and that an object has been discharged by the carriage. Knowing the weight may also confirm that the object in the carriage is indeed the object that the system expects is in the carriage (where the system includes previously recorded data regarding each object's weight).

In accordance with an aspects, the invention provides an automated material handling system that is tasked, in part, with routing objects carried in bins to stations where objects are transferred from one bin to another with one or more programmable motion devices (such as articulated arms) at automated stations, and may further include manual stations. The objects may be provided in bins, which may be containers, totes, or boxes etc. An overall objective of the system may be to sort and ship goods, to perform order fulfillment, to replenish store stock, or to provide any general-purpose system requiring the transfer of individual objects from one bin to a processing system.

The objects may be packages, boxes, flats or polybags etc. in a shipping center, or consumer products in an e-commerce order fulfillment center, or products and warehouse packs in a retail distribution center (DC). The conveyance of objects or bins of objects could take many forms, including belt or roller conveyors, chutes, mobile robots, or human workers. The picking stations, where items are transferred, might be automated systems including robotic systems, or a station manned by a human being.

Figure 31 shows a diagrammatic view of an induction limiting system 300 that includes an infeed conveyor 302 that leads to a classification system 304. Once classified by the classification system 304, objects are directed toward a routing system 306, which routes the objects to one of a plurality of directions as shown at 308, 310, 312. A model for a system similar to that shown in Figure 11 for example, is shown in Figure 32. The system 320 of Figure 32 includes an infeed conveyor 322 that directs objects to a classification system 324. The classification system 324, in combination with one or more computer processing systems 100, 200 and a database therein or coupled thereto, directs the objects toward a routing system 330

(via a conveyor 328), and directs empty bins along a bin outbound conveyor 326. The routing system 330 directs the objects into one of three different directions. Objects that are accepted for processing are directed along a conveyor 332 for processing by the object processing system 334. Objects that are outside of system specifications for processing, are directed along a non-processable objects conveyor 344 for processing by systems or methods other than the processing system 334. Certain objects that do not fall directly into either classification (e.g., objects that are provided in polyethylene bags) are provided to a bag processor 338 via a bag processing conveyor 336. At the bag processor 338, the objects are subjected to a test, and depending on the results are either directed toward the object processor 334 via processor 340, or are directed toward the non-processable objects station via a conveyor 342.

Systems of the invention may be employed in a wide variety of routing system applications. For example, induction limiting systems of the invention may be employed with multiple routing and processing system. Figure 33, for example, shows a system 350 that includes an infeed conveyor 352 that provides objects to a classification system 354. The classification system 354 determines which of a plurality of processing systems (e.g., A, B or C as shown at 362, 370, 374) to have the object sent. In particular, objects first leave the classification system 354 and travel along a conveyor 356 toward a first routing system 358. Certain objects (that are determined by the classification system 354) to be directed toward the processing system (A) 362, are directed along conveyor 360 toward processing system (A) 362. All other objects are directed along conveyor 364 toward a second routing system 366. Further objects (that are determined by the classification system 354) to be directed toward the processing system (B) 370, are directed along conveyor 368 toward processing system (B) 370. All other objects are directed along conveyor 372 toward routing system 374. Any of processing systems A, B or C may, for example, be automated processing stations (e.g., designed for large or small / heavy or light objects) or manual processing stations (e.g., at which a person may make decisions regarding object processing, or physically move objects to destination locations). In further aspects, the station C may be a pass-through exceptions bin into which objects that are to be processed manually are deposited.

As an example, Figure 34 shows the induction system 10 and object processing system 12 as discussed above with reference to Figures 1 – 8 together with additional object processing systems 25 and 26 in series. In particular, the induction system 10 includes an input station 14 with the response evaluation section 16 of conveyor 22, the multipurpose perception unit 24 and weight sensing conveyor section 55 for evaluating objects (e.g., 28), and providing objects either

to the exception bin 50 via conveyor 35 (e.g., object 35) or to conveyor 41 (e.g., objects 40, 42) using the multidirectional conveyor 53 as discussed above with reference to Figures 1 – 8.

The objects to be processed (e.g., objects 40, 42) are each assigned an object processing station (e.g., 12, 25, 26) toward which they are routed. In particular, the objects to be processed (again, e.g., 40, 42) may be routed to an appropriate processing station based on any of a variety of parameters, such as size, weight, packaging material (boxes, bags, odd shaped objects etc.), and even shipping location, and each object processing station may, for example, include components that are particularly suited for certain sizes, weights, packaging materials etc. Certain objects may be routed by multidirectional conveyor 44 along conveyor 46 to object processing station 12, while others (e.g., objects 49, 52, 54) are directed along conveyor 48 toward further processing stations. Certain of those objects may be routed by multidirectional conveyor 56 along conveyor 58 toward object processing station 25, while others (e.g., objects 61, 62, 63) are directed along conveyor 60 toward further processing stations. Certain of these objects may be routed by multidirectional conveyor 64 along conveyor 65 toward processing station 26, while others (e.g., 67) are directed along conveyor 66 toward further object processing stations. The operation of the systems may be controlled by one or more computer processing systems (e.g., 100, 68 and 69).

As another example, Figure 35 shows the induction system 11 and object processing system 12 as discussed above with reference to Figures 9 and 10, together with additional object processing systems 25 and 26 in series. In particular, the induction system 11 includes an input station 14 with the response evaluation section 16 of conveyor 22, the multipurpose perception unit 24 and weight sensing conveyor section 55 for evaluating objects, and providing objects to any of an exception bin via conveyor 134 or to conveyor 138 or to a bag processing conveyor 144 using the multidirectional conveyor 132 as discussed above with reference to Figures 9 and 10. Any objects that are detected as being packaged in bags are directed to conveyor 144 toward deformable object induction system 194 including articulated arm 192, where objects are tested as discussed above with reference to Figures 9 and 10, and either directed along non-processable object conveyor 196 or along processable object conveyor 198 as discussed above with reference to Figures 9 and 10.

Again, the objects to be processed are each assigned an object processing station (e.g., 12, 25, 26) toward which they are routed. In particular, the objects to be processed (e.g., 43, 52, 54) may be routed to an appropriate processing station based on any of a variety of parameters, such as size, weight, packaging material (boxes, bags, odd shaped objects etc.), and even shipping location, and each object processing station may, for example, include components that

are particularly suited for certain sizes, weights, packaging materials etc. Certain objects may be routed by multidirectional conveyor 45 along conveyor 19 to object processing station 12, while others (e.g., objects 43, 52, 54) are directed along conveyor 47 toward further processing stations. As discussed above with reference to Figure 34, certain of those objects may be routed by multidirectional conveyor 56 along conveyor 58 toward object processing station 25, while others (e.g., objects 61, 62, 63) are directed along conveyor 60 toward further processing stations. Certain of these objects may be routed by multidirectional conveyor 64 along conveyor 65 toward processing station 26, while others (e.g., 67) are directed along conveyor 66 toward further object processing stations. The operation of the systems may be controlled by one or more computer processing systems (e.g., 200, 68 and 69).

Figure 36 shows a system that includes the induction system 13 and object processing system 12 as discussed above with reference to Figures 11 – 22D, together with additional object processing systems 25 and 26 in series. In particular, the induction system 13 includes an input station 114 including a bin in-feed conveyor 122, a bin output conveyor 126, an articulated arm 132 and an object in-feed conveyor 13, and providing objects to any of an exception bin via conveyor 134 or to conveyor 138 using the multidirectional conveyor 132 or to a bag processing conveyor 144 as discussed above with reference to Figures 11 – 22D. Any objects that are detected as being packaged in bags are directed to conveyor 144 toward deformable object induction system 194 including articulated arm 192, where objects are tested as discussed above with reference to Figures 11 – 22D, and either directed along non-processable object conveyor 196 or along processable object conveyor 198 as discussed above with reference to Figures 11 – 22D.

Again, the objects to be processed are each assigned an object processing station (e.g., 12, 25, 26) toward which they are routed. In particular, the objects to be processed may be routed to an appropriate processing station based on any of a variety of parameters, such as size, weight, packaging material (boxes, bags, odd shaped objects etc.), and even shipping location, and each object processing station may, for example, include components that are particularly suited for certain sizes, weights, packaging materials etc. Certain objects may be routed by multidirectional conveyor 59 along conveyor 51 to object processing station 12, while others (e.g., objects 52, 53, 54) are directed along conveyor 47 toward further processing stations. As discussed above with reference to Figure 35, certain of those objects may be routed by multidirectional conveyor 56 along conveyor 55 toward object processing station 25, while others (e.g., objects 61, 62, 63) are directed along conveyor 60 toward further processing stations. Certain of these objects may be routed by multidirectional conveyor 64 along conveyor 65 toward processing station 26, while

others (e.g., 67) are directed along conveyor 66 toward further object processing stations. The operation of the systems may be controlled by one or more computer processing systems (e.g., 200, 68 and 69).

Figure 37 shows the induction system 15 and object processing systems 12, 17, 21, 23 in parallel. The induction system 15 includes not only the input station 14 including the response evaluation section of conveyor 22, the multipurpose perception unit 24, the weight sensing conveyor section 55 and the multidirectional conveyor 53 as discussed above with reference to Figures 1 – 8, the induction system 15 further includes a plurality of sets of multipurpose perception units, weight sensing conveyor sections and multidirectional conveyors for evaluating objects (e.g., 28). Multidirectional conveyor 53 leads to conveyor 41 and multidirectional conveyor 44 for providing objects (e.g., 40, 42) to object processing system 12 via conveyor 46 as well as any additional object processing systems (e.g., object 49 on conveyor 48) in series with the object processing system 12 as discussed above with reference to Figure 34.

In particular, conveyor 22 also includes an additional inspection station 86 with a multipurpose perception unit 85, a weight sensing conveyor section 87 and a multidirectional conveyor 88 for evaluating objects (e.g., 81), and for optionally directing objects (e.g., 83, 89) along conveyor 31 toward a multidirectional conveyor 90. Multidirectional conveyor 90 leads to conveyor 91 for providing objects to object processing system 17 as well as to any additional object processing systems (e.g., object 93) along conveyor 92 in series with the object processing system 17.

Conveyor 22 further includes an additional inspection station 96 with a multipurpose perception unit 95, a weight sensing conveyor section 97 and a multidirectional conveyor 99 for evaluating objects (e.g., 98), and for optionally directing objects (e.g., 111, 113) along conveyor 151 toward a multidirectional conveyor 115. Multidirectional conveyor 115 leads to conveyor 117 for providing objects to object processing system 21 as well as to any additional object processing systems (e.g., object 121) along conveyor 119 in series with the object processing system 21.

Conveyor 22 further includes an additional inspection station 127 with a multipurpose perception unit 125, a weight sensing conveyor section 129 and a multidirectional conveyor 131 for evaluating objects (e.g., 137), and for optionally directing objects (e.g., 139, 141) along conveyor 153 toward a multidirectional conveyor 145. Multidirectional conveyor 145 leads to conveyor 147 for providing objects to object processing system 23 as well as to any additional object processing systems (e.g., object 155) along conveyor 149 in series with the object processing system 21. Objects (e.g., 28, 36, 81, 94, 98, 123, 137) may therefore be routed along

conveyor 22 to any of a plurality of processing stations, and then directed along a transverse conveyor (e.g., 41, 31, 151, 153) to any of a plurality of processing stations in series along the transverse conveyor. Non-processable objects (e.g., object 157) may be provided to an exception bin 159 at the end of the conveyor 22. Operation of the system may be controlled by one or more computer processing systems 100, 161, 163, 165. Again, the objects to be processed may be routed to an appropriate processing station based on any of a variety of parameters, such as size, weight, packaging material (boxes, bags, odd shaped objects etc.), and even shipping location, and each object processing station may, for example, include components that are particularly suited for certain sizes, weights, packaging materials etc.

Figure 38 shows a plurality of different types of induction systems used with a plurality of object processing systems. The induction system 114 includes the input bin conveyor 122, output bin conveyor 126 and articulated arm 116, weight sensing conveyor 155, multidirectional conveyor 132, deformable object induction limiting system 194 and articulated arm 192 as discussed above with reference to Figures 11 – 22, together with conveyors 57, 130, 138, 144, 196, 134 and 198. Conveyors 138 and 198 lead to multidirectional conveyor 59, where objects are either directed to object processing system 12 via conveyor 51, or are directed along conveyor 57 (e.g., object 53) toward one of a plurality of further object processing systems as discussed above with reference to Figure 36. The multidirectional conveyor 132 however does not lead to a non-processable object collection bin, but rather leads to further induction systems via conveyor 181.

In particular, conveyor 181 leads to an induction system 14 that includes the response evaluation section 16, the multipurpose perception unit 24, the weight sensing conveyor section, multidirectional conveyor 132 and deformable object induction limiting system 194 and articulated arm 192 as discussed above with reference to Figures 9 and 10, together with conveyors 19, 22, 138, 144, 196 and 198. Conveyors 138 and 198 lead to multidirectional conveyor 45, where objects are either directed to object processing system 177 via conveyor 19, or are directed along conveyor 47 (e.g., object 43) toward one of a plurality of further object processing systems as discussed above with reference to Figure 35. Again, the multidirectional conveyor 132 does not lead to a non-processable object collection bin, but rather leads to a further induction systems via conveyor 183.

Conveyor 183 leads to a further induction system 14 including the response evaluation section 16, the multipurpose perception unit 24, the weight sensing conveyor section, multidirectional conveyor 132 and deformable object induction limiting system 194 and articulated arm 192 as discussed above with reference to Figures 1 - 8, together with conveyors

22, 40, 46, 48 and 35. Conveyor 41 leads to multidirectional conveyor 44, where objects are either directed to object processing system 179 via conveyor 46, or are directed along conveyor 48 (e.g., object 49) toward one of a plurality of further object processing systems as discussed above with reference to Figure 34. Objects that are not to be processed (e.g., object 36) are provided to non-processable object exception bin 50 via conveyor 35.

Again, the objects to be processed are each assigned an object processing station (e.g., 12, 177, 179) toward which they are routed. In particular, the objects to be processed may be routed to an appropriate processing station based on any of a variety of parameters, such as size, weight, packaging material (boxes, bags, odd shaped objects etc.), and even shipping location, and each object processing station may, for example, include components that are particularly suited for certain sizes, weights, packaging materials etc. Operation of the system may be controlled by one or more computer processing systems 100, 200, 301.

Any of a wide variety of detection systems may also be employed in the above disclosed and further aspects of the present invention. For example, as discussed above with regard to the weight sensing conveyors discussed above, such a weight sensing conveyor may be provided in a wide variety of systems. For example, and with reference to Figures 39A and 39B, a weight sensing conveyor system 380 that may be used in an induction system of any of Figures 1, 9, 11, 34 – 38, 49, 56 and 70, and that include a weight scale 382, including a base 384 and a scale 386, that is provided between upper 388 and lower 390 portions of a conveyor section 392. Objects on the conveyor may thereby be weighed while on the conveyor.

Figures 40A and 40B show a weight sensing conveyor system 400 that may be used in an induction system of any of Figures 1, 9, 11, 34 – 38, 49, 56 and 70, and that includes a conveyor section 402 that is mounted on rollers 404, 406, each of which is mounted at both ends on a pair of load cells 408, 410 (only one of which is shown at one end of each roller 404, 406). Damaged packages may also be identified by the perception system, for example, if a package appears to be wet or leaking. Moisture sensitive sensors may be employed in connection with conveyor 382 in any of the pre-processing systems of Figures 1, 9, 11, 34 – 38, 49, 56 and 70 by having a load cell 408, 410 include moisture sensors. In other embodiments, cameras (e.g., one trillion fps cameras that are able to track photons) that are able to detect moisture may also be used in such induction systems. Any dampness detected would indicate that the object is likely damaged, requiring exception processing.

With reference to Figures 41A – 41D, the system 400 may further provide that an object 412 on the conveyor section 402 may determine not only the weight of the object 412, but may further use the difference between the ends of the lengths and the ends of the widths, as well as

weights perceived by each of the load cells 408, 410, to determine an area of the center of mass of the object 412 in accordance with a further aspect of the present invention. The system 400 may, for example, be used in any of the induction systems of Figures 1, 9, 11, 34 – 38, 49, 56 and 70.

With reference to Figures 42A and 42B, a weight scale such as that shown in Figures 39A – 39B, may be provided as multiple scales. Figures 42A and 42B, for example, show the scale system 420 that includes four scale sections 422, 424, 426, 428 on a scale base 430. The scale system 420 may be used in any of the pre-processing systems of Figures 1, 9 and 11. Using such a scale system, the use of the multiple scales may also be employed to locate a center of mass of an object on the scale system 420.

Figures 43A – 43C show a scale system 440 that includes multiple rollers 442 mounted within a frame 444 on a base 446, wherein each roller 442 is mounted to the frame 444 via a load cell or force torque sensor 446 on either end of the each roller 442. The system 440 may be used in any of the pre-processing systems of Figures 1, 9 and 11. By monitoring the outputs of each of the load cells or force torque sensors 446, the center of the mass of an object on the rollers may be determined.

Such systems therefore, that provide weight sensing in the presentation conveyor may include one or more load cells or weight sensitive mechanisms embedded into the surface on which objects are presented to a programmable motion device such as an articulated arm. Each object's weight and/or observed density (weight / volume) as may be estimated using the programmable motion system's cameras or range sensors that can perceive volume. Objects may be diverted or otherwise pass by the processing system when these values exceed specifications. To better localize incompatible objects (e.g., packages), there may be a grid of such weight sensitive mechanisms that are able to sense which region of the picking area contains the one or more incompatible objects, and then allow picking from any area except where the incompatible object(s) has been detected. Further, the systems may detect flow readings while gripping an object. If a flow of air (F_1) is too high (as compared to an expected flow (F_2)) for a particular object, then the system may permit the object to be diverted from or move past an object processing system.

In further aspects therefore, the end effector of the programmable motion device (and as discussed herein with reference to Figures 9 – 22D, 35, 36, 38, 54, 70 and 71) may include an end effector 450 as shown in Figure 44 that includes a load cell or force torque sensor 454 that separates an upper portion 452 that is coupled to the programmable motion device, and a lower portion 458. The system may employ the load sensitive device at the gripper to estimate the

weight of the object. If the object exceeds an acceptable weight specification, the object is released into a stream directed toward an exception area. Also, any movement of the lower portion with respect to the upper portion will be detected by the load cell. A weight therefore of any object that is being grasped by the flexible bellows 456 under vacuum, may be determined. Although an object may move with respect to the lower portion 458 (e.g., by use of the flexible bellows), any movement of grasped object that translates to movement of the lower portion 458 with respect to the upper portion 452 will be detected by the load cell or force torque sensor 454. Not only weight therefore, but also a balance/imbalance of the grasp, as well as any torque being applied to the lower portion 458 will also be detected. Again, if the sensed (estimated) weight of an object being grasped exceeds either an expected weight (beyond a threshold), then the system may release the object either to be simply diverted from the processing station, or to be directed to an exception area.

In accordance with further aspects, the system may limit the initial grip force. For example, the system may employ a partially open gripper valve to limit the maximum grip force (V_1) in a vacuum gripper 450 until an object is lifted. Once the object is lifted, the gripper valve may be fully closed, bringing the vacuum force to a greater vacuum (V_2) to execute a secure and reliable transfer of the object. Such a process ensures that objects will not be dropped during transfer, and limits the induction of objects to the processing system that are potentially at risk of being dropped or not processed properly.

Figure 45 shows an end effector 460 for use in a system in accordance with a further aspect of the present invention that includes a rigid portion 462 that is coupled to the programmable motion device, and a flexible bellows 464 that may move with respect to the rigid portion. Attached to a lower portion of the flexible bellows 464 is a rigid bracket 466 that includes a band portion around the flexible bellows, and a vertical portion 465 that is orthogonally disclosed with regard to the band portion. The top of the vertical portion includes either a magnet or a sensor, and mounted on the end effector is the other of either a magnet or a sensor pair 468, 469. The magnet and sensor pair provide that any movement of the bottom of the end effector with respect to the rigid portion 462 of the end effector, will be detected by the sensor system. In this way, any of a weight of an object, or characterization of a grasp of any object (e.g., balance/imbalance, or torque applied to the end effector) may also be determined. The end effector 460 may be used with any of the end effector systems discussed herein with reference to Figures 9 – 22D, 35, 36, 38, 54, 70 and 71.

With reference to Figure 46, the system may use an end effector 455 (such as any end effector discussed herein) that includes a sensor 457 such as a flow sensor or pressure sensor.

The system may compute from observations of flow and/or pressure while holding an item, whether the gripper 459 has a sufficient grasp on an object. In particular, the system may measure flow readings when gripping an object and determine whether the measured values are within a pickable object range of values. If the object is not pickable, the object may be passed to an exception area without being processed. The end effector 455 may be used with any of the systems discussed above with reference to Figures 10A – 13 and 54.

Figures 47 and 48 show a carriage 470 for use in a system in accordance with an aspect of the invention similar to that shown in Figures 23, 25 and 28A – 30 having a body 472 that includes a taller back wall 474 against which objects may be re-directed into the generally V-shaped body 472 of the carriage. The carriage 470 is mounted via load cells or force torque sensors 476, 478 on a frame 480, and its motion along a rail and in tipping, is controlled by actuation system 482. Communication and electronic controls are provided by electronic processing and communication system 488 (shown in Figure 43). Again, the load cells or force torque sensors 476, 478 may be used to determine the weight of the contents of the carriage. For example, once an object is detected by the beam-break transmitter and receiver pair 484, 486, the system in accordance with an embodiment, will average the weight value of the two load cells (W_1 , W_2) together, double the result, and subtract the weight of the body 472. In accordance with other embodiments, the load cells themselves may register a change, indicating that the carriage has received or expelled an object.

Many further filter systems, diverter systems, testing systems, routing systems and processing systems may be used in the above aspects and further below aspects of the invention. For example, certain embodiments may involve approaches to filtering packages that are too heavy, and doing so before they reach one of the robot pickers. Such systems may include a passive bomb-bay drop system. Such a system may involve routing incoming packages over a chute with a bomb-bay door or doors. The bomb-bay door is held closed by a spring whose stiffness is tuned so that packages that are too-heavy fall through the bomb-bay door. Packages whose weight is less than the limit, do not exert enough force to open the passive bomb-bay door(s). The passive bomb-bay door is mounted to a chute, so that packages fall naturally or slide over the bomb-bay without dropping.

In accordance with further aspects therefore, filtering systems of the invention may include an actuatable bomb-bay drop system (e.g., motor actuated or spring loaded). A sensor measures the weight of packages as they travel over the bomb-bay door(s), and a controller opens the bomb-bay door(s), either by a motor to open the bomb-bay, or by a mechanism that unlocks

the bomb-bay door, and then a motor that closes it again in accordance with an aspect of the invention.

Figure 49 shows an induction system 487 with an object processing system 12. The induction system 487 includes an input section 14 including a response evaluation section 16 of a conveyor 22, side perception units 18, overhead perception units 20, multipurpose perception unit 24, weight sensing conveyor section 53 and multidirectional conveyor 33 as discussed above with reference to Figures 1 – 8, as well as an exception bin 21 for receiving non-processable objects (e.g., 36) via conveyor 35. The induction system 487 also includes a sloping conveyor 492 that includes sections 495, 496 and 497 and travels over a second lower conveyor 489. With further reference to Figures 50A and 50B, when an object 499 travels from the conveyor section 495 onto the conveyor section 496, weight sensors (e.g., force torque sensors) 485 detect the weight of the object. If the object is either above or below a specified weight, the object is dropped onto the lower conveyor 489 and is routed via multidirectional conveyor 493 toward object processing system 12 via conveyor 491. The system may elect to drop an object through the bomb-bay doors 498 if the object is too heavy or too light for processing by processing stations coupled to the conveyor section 497 as discussed above. The doors may be actuated by motors 483. Alternatively, the bomb-bay conveyor may be designed to operate via spring mechanisms that open when the weight is above a threshold, and the conveyor 497 may lead to appropriate object processing systems.

Figures 51A and 51B show end views of the bomb-bay doors 498 over the conveyor 494 where the doors are closed (Figure 51A), and opened (Figure 51B), such as by a spring or motor actuator responsive to input from force torque sensors, for dropping an object 499 from the upper conveyor 496 to the lower conveyor 489. In accordance with further aspects, the doors may include weight-triggered flexible interlocking fingers or tynes, such as, for example shown in Figures 66A and 66B.

Figures 52A and 52B, for example, show a system 491 that includes an upper sloped conveyor system 492 that runs above a lower sloped conveyor 494. The system 491 may be used with any of the induction systems of Figures 1, 9 and 11, replacing one or more of the conveyors shown in Figures 1, 9 and 11, e.g., as shown by example in Figure 49. The lower conveyor 494 of such systems may alternately lead to an exception bin. The upper conveyor 492 includes active conveyor sections 495, 497, as well as set of bomb-bay doors. The upper conveyor 492 (as well as the lower conveyor 494) may be inclined (extend in *X* and *Y* directions), such that an object 499 on top of the doors 498 may slide over the doors to the next conveyor section 497 if it is not dropped. With reference to Figure 52B, if the doors 498 are passive bomb-bay doors,

and if the object 499 is too heavy (e.g., overcomes a spring mechanism), then the doors 498 will open dropping the object 499 to the lower conveyor 494. If the doors 498 are motor-actuated bomb-bay doors, and if the object 499 is determined to be too heavy (e.g., by a different weighing system disclosed above such as if conveyor section 495 is a weighing conveyor as discussed above), then the doors 498 will be opened by a motor, dropping the object 499 to the lower conveyor 494.

Figure 53 shows an air-permeable conveyor 500 that includes a conveyor material 506 with openings 508 therein that permit air to flow through the material 506. The air-permeable conveyor 500 may be formed of a perforated, mesh or woven material and is driven over rollers 502, 504, and one roller (e.g., 502) includes openings 503 and provides a vacuum through the openings 503 into the roller 502. Such a system may be used in an induction system 489 with an object processing system 12 as shown in Figure 54.

The induction system 489 of Figure 54 includes an input section 14 including a response evaluation section 16 of a conveyor 22, side perception units 18, overhead perception units 20, multipurpose perception unit 24, weight sensing conveyor section 53 and multidirectional conveyor 33 as discussed above with reference to Figures 1 – 8, as well as an additional conveyor 509 leading to the air-permeable conveyor 500. The free end of the air-permeable conveyor is positioned over two or more receiving stations, which may be conveyors, chutes, or automated carriers. Three automated carriers 513, 515, 517 are shown in Figure 54. Objects that are to be processed, may be routed by multidirectional conveyor 33 to conveyor 511, which runs between a pair of articulated arms 521, 523 as well as a pair of conveyors 525, 527, which via further multidirectional conveyors 529, 533 lead to object processing conveyors 531 (leading to object processing system 12), and 535.

With further reference to Figure 55A, objects may be provided on the conveyor 500 with the vacuum applied, and as objects pass around the outside of the roller, the heavier ones may directly fall from the conveyor (e.g., object 503) into bin 513 as shown in Figure 55B. Somewhat lighter objects (e.g., 505) may travel farther under the roller 502 into bin 515 as shown in Figure 55C, and very light objects (e.g., 507) may drop from the now upside down conveyor 506 into bin 517 only when the conveyor leaves the vacuum provided through the roller 502, as shown in Figure 55D. With such a system, the objects also need not be singulated on the conveyor since objects next to each other will fall according to their own response to the vacuum. Additionally, one or more perception systems 692 may monitor the actions of objects being dropped from the conveyor, and may communicate with one or more control systems 694 to adjust any of the vacuum pressure at the conveyor (via vacuum controller) 696 or conveyor speed (via rotational

speed controller) 498. The system of Figures 53 and 55A – 5D may be used for example, in further systems as disclosed herein.

Again, the receiving stations may be any of automated carriers, chutes or conveyors. Figure 56 shows an induction system 647 that includes an input section 14 including a response evaluation section 16 of a conveyor 22, side perception units 18, overhead perception units 20, multipurpose perception unit 24, weight sensing conveyor section 53 and multidirectional conveyor 33 as discussed above with reference to Figures 1 – 8, as well as an additional conveyor 509 leading to the air-permeable conveyor 500. In this example, the air-permeable conveyor is positioned over an automated carrier 513', a chute 515' that leads to an automated carrier 649, and a carrier 517'. Objects that are to be processed, may be routed by multidirectional conveyor 33 to conveyor 537, which runs between a pair of conveyors 541, 545, which via further multidirectional conveyors 551, 555 lead to object processing conveyors 553 (leading to object processing system 12), and 557. The conveyors 537, 541 and 545 also pass through an object transfer station 547 as discussed further below with reference to Figures 57 – 69, and in some examples, conveyors 541 and 545 are lower than conveyor 537, while in other examples, each is at the same height. At the object transfer station, objects are transferred from a conveyor to any of a variety of further units such as to other conveyors, chutes or mobile units.

In accordance with further aspects of the invention for example, induction systems may be used that may discriminate between objects by passing objects by an air blower that pushes lighter packages from a stream of packages, leaving the heavier packages. The heavier packages' larger inertia overcomes the air resistance arising from the blown air. For lighter packages, the air resistance exceeds the lighter packages' lower inertia. The air flow are tuned to so that for common package types, the stream blown away contains to the greatest extent those packages meeting the weight specifications.

Figure 57 for example, shows an air permeable conveyor 501 similar to that discussed above with reference to Figure 53 that is designed to permit a substantial amount of air to be blown through openings 508 in a web 506 that moves (providing the conveying surface) along rollers. As shown in Figure 57 such an air-permeable conveyor 501 may be used in a system 510 in which objects are moved along an approach conveyor 512, and over the air-permeable conveyor 501. Below the air-permeable conveyor 501 is a blower source 514 that blows air through the air-permeable conveyor 500, and above the air-permeable conveyor 501 is a vacuum source 516 that draws air through the air-permeable conveyor 501. Both the blower 514 and the vacuum source 516 may include a screen or array of openings (as partially shown in Figure 60). The combination of the blower 514 and the vacuum source 516 will cause some objects to be

lifted off of the conveyor 501. Objects that are too heavy to be lifted off of the conveyor 501 will travel along the conveyor 501 and be transferred to a follower conveyor 518. The system 510 may be used in place of any of the conveyors in the systems of Figures 1, 9 and 11 with the lighter objects being then routed to a light object processing station as discussed further with reference to Figures 59A – 59C.

Additionally, and as shown in Figure 58, the system may further include one or more perception systems 521 that communicate with a vacuum control processor 523 coupled to a vacuum controller 525, and that communicate with a blower control processor 527 coupled to a blower controller 529. In this way, operation of the system may be monitored and rate of flow of air by the blower and the vacuum may be adjusted as required.

With reference to Figure 59A, when an object 520 is lifted toward the vacuum source 516, it is initially pushed by air from the blower source 514 and lifted by the vacuum source 516. Once the object contacts a screen on the vacuum source 516, the vacuum force will be strong enough that the air from the blower is no longer necessary to hold the object against the vacuum source 516. The vacuum source 516 may be movably mounted on a rail 522 such that the vacuum source 516 may be moved to be positioned over any of conveyor 501 or adjacent conveyors 524, 526. With reference to Figure 59B, the vacuum source 516, for example, may be moved over conveyor 524 while holding the object 520, and may then cease the vacuum, permitting the object to fall onto the conveyor 524 as shown in Figure 59C. The vacuum source 516 is then returned to the position over the conveyor 501. In this way, vacuum sources and/or blower sources may be used to distinguish and separate objects of different characteristics such as weight or mass.

In accordance with further aspects, the system may further provide bulk picking by such vacuum systems. Objects may pass by an area in which a large vacuum surface is suspended upside down over the objects. The system may grip objects in bulk - many at a time - but is only able to achieve a lift for light objects, while heavy objects are not lifted out of the object stream. The balance of vacuum lifting force versus weight and packaging material may be adjusted such that either all objects that remain have a minimum weight, or that all objects that are lifted are below a maximum weight.

Induction systems in accordance with a further embodiment of the invention may include system 530 that includes a blower source 532 and a vacuum source 534 that are positioned on either side of an air-permeable conveyor 536 as shown in Figure 60. The use of the air-permeable conveyor may facilitate drawing certain objects toward the vacuum source 532 by permitted a greater flow of air. The conveyor 536 is fed objects by an in-feed conveyor 538, and provides objects (that are not removed from the conveyor 536 by the blower source 532 and vacuum

source 534) to an out-feed conveyor 539. Objects that are removed from the conveyor 536 fall onto any of another conveyor below and to the side of the conveyor 536 or a chute or other mobile carrier as discussed in more detail below. Monitoring and control systems similar to that of Figure 58 may also be used with the system of Figure 60.

With reference to Figure 61, a system 540 in accordance with a further embodiment of the invention may include a blower source 542 and a vacuum source 544 that are positioned on either side of an air-permeable conveyor 546, as well as another blower source 543. The conveyor 546 is fed objects by an in-feed conveyor 548, and provides objects (that are not removed from the conveyor 546 by the blower sources 542, 543 and vacuum source 544) to an out-feed conveyor 549. The blower source 543 may further facilitate moving objects with the blower source 542 and the vacuum source 544. Again, objects that are removed from the conveyor 546 fall onto any of another conveyor below and to the side of the conveyor 536 or a chute or other mobile carrier as discussed in more detail below. Monitoring and control systems similar to that of Figure 58 may also be used with the system of Figure 61.

In applications where objects may be light enough to be moved off of a non-perforated conveyor (and/or the blower and vacuum source is high), a system 550 may be provided that includes a blower source 552 and a vacuum source 554 that are positioned on either side of a conveyor 556 as shown in Figure 62. The conveyor 556 is fed objects by an in-feed conveyor 558, and provides objects (that are not removed from the conveyor 556 by the blower source 552 and vacuum source 554) to an out-feed conveyor 559. Again, objects that are removed from the conveyor 556 fall onto any of another conveyor below and to the side of the conveyor 556 or a chute or other mobile carrier as discussed in more detail below. Monitoring and control systems similar to that of Figure 58 may also be used with the system of Figure 62.

As noted above, objects may be routed to any of chutes, conveyors, mobile carriers etc. Figure 63, for example, shows a system 560 that includes a central conveyor having an in-feed conveyor section 562, an out-feed conveyor section 564, and a weight-sensing conveyor 566 as discussed above with reference to Figures 39A – 43C. The system 560 also includes a pair of sources 568, 570 on either side of the weight-sensing conveyor 566, and each source 568, 570 may provide either forced air via a blower or vacuum, such that objects may be moved by a blower – vacuum pair in either direction off of the conveyor 566.

With further reference to the side view shown in Figure 64, objects may either be blown onto a chute 572 that leads to a conveyor 574 (e.g., by engaging source 570 as a blower and source 568 as a vacuum source), or may be blown onto a chute 576 that leads to a mobile carrier 578 (e.g., by engaging source 568 as a blower and source 570 as a vacuum source). The selection

of whether an object is to be moved to either the conveyor 574 or the mobile carrier 578 may be a result of the air flow between sources 568, 570, or in other aspects, may be triggered by a detected weight of an object on the conveyor 566. In further aspects, the weight-sensing conveyor 566 may be employed to confirm an object's weight, and further to provide feedback to the control system (e.g., 100) such that the sources (together or independently) may be adjusted to more finely tune their object removal capability.

Figure 65 shows a system 600 that includes a central conveyor having an in-feed conveyor section 602, an out-feed conveyor section 604, and a weight-sensing multi-directional conveyor 606. The weight-sensing multi-directional conveyor 606 may include weight-sensing rollers 442 as discussed above with reference to Figure 39A – 43C, as well as a series of orthogonally disposed narrow conveying belts 608. Either of the rollers 442 or the belts 608 may be lowered/raised with respect to the other, to provide that objects may either remain on the conveyor 606 and be provided to the out-feed conveyor 604, or may be routed by the belts 608 either to a chute 610 that leads to a conveyor 612, or to a chute 614 that leads to a mobile carrier 616. The selection of whether an object is to be moved to either the conveyor 612 or the mobile carrier 616 or remain on the conveyor 606 may be triggered by a detected weight of an object on the conveyor 606. The mobile carrier 616 may include a bin or box into which a received object is dropped, and the mobile carrier 616 may be moved about a track system as discussed in more detail below.

Figures 66A and 66B show a system 620 in accordance with a further embodiment of the invention that includes a central conveyor having an in-feed conveyor section 622, an out-feed conveyor section 624, and a weight-sensing multi-directional conveyor 626. Again, the weight-sensing multi-directional conveyor 626 may include weight-sensing rollers 442 as discussed above with reference to Figure 39A – 43C, as well as a series of orthogonally disposed narrow conveying belts 628. Either of the rollers 442 or the belts 628 may be lowered/raised with respect to the other, to provide that objects may either remain on the conveyor 626 and be provided to the out-feed conveyor 624, or may be routed by the belts 628 either to a chute 630 that leads to a conveyor 632, or to a chute 634 that leads to a mobile carrier 636. Additionally, the chute 630 includes bomb-bay doors 638 that open above a further conveyor 639. The bomb-bay doors 638 may be either motor activated or designed to release by spring under a certain weight threshold as discussed above with reference to Figures 49 – 52B. The selection of whether an object is to be moved to either the conveyor 612, the conveyor 639 or the mobile carrier 616, or remains on the conveyor 626 may be triggered by a detected weight of an object on the conveyor 606. Again,

the mobile carrier 616 may include a bin or box into which a received object is dropped, and the mobile carrier 616 may be moved about a track system as discussed in more detail below.

Figure 67 shows a system similar to system 560 of Figure 63, including a central conveyor having an in-feed conveyor section 562, an out-feed conveyor section 564, and a weight-sensing conveyor 566 as discussed above with reference to Figures 39A – 43C. The system 560 also includes a pair of sources 568, 570 on either side of the weight-sensing conveyor 566, and each source 568, 570 may provide either forced air via a blower or vacuum, such that objects may be moved by a blower – vacuum pair in either direction off of the conveyor 566. In addition to the chute 576 leading to the automated carrier 578, the system of Figure 67 includes a chute 573 with a pair of bomb-bay doors 577 (as discussed above with reference to Figures 49 – 51B) for selectively providing an object either to the conveyor 574 or dropping an object onto conveyor 575 that is adjacent conveyor 574.

Figures 68A and 68B show a system 580 that includes a central conveyor having an in-feed conveyor section 582, an out-feed conveyor section 584, and a weight-sensing conveyor 586 as discussed above with reference to Figures 39A – 43C. The system 580 also includes a pair of paddles 588, 590 on either side of the weight-sensing conveyor 586, and each paddle 588, 590 may be used to urge an object on the weight-sensing conveyor 586 off of the conveyor 586 in either direction, or an object may remain on the conveyor 586 and be moved to out-feed conveyor section 584. With further reference to the Figure 68B, objects may either be urged onto a chute 592 that leads to a conveyor 594, or may be urged onto a chute 596 that leads to a mobile carrier 598. The selection of whether an object is to be moved to either the conveyor 574 or the mobile carrier 578 or remain on the conveyor 586 may be triggered by a detected weight of an object on the conveyor 586. The mobile carrier 598 may include a bin or box into which a received object is dropped, and the mobile carrier 598 may be moved about a track system as discussed in more detail below.

Figure 69 shows a system similar to that of Figures 68A and 68B that includes a central conveyor having an in-feed conveyor section 582, an out-feed conveyor section 584, and a weight-sensing conveyor 586 as discussed above with reference to Figures 39A – 43C. The system 580 also includes a pair of paddles 588, 590 on either side of the weight-sensing conveyor 586, and each paddle 588, 590 may be used to urge an object on the weight-sensing conveyor 586 off of the conveyor 586 in either direction, or an object may remain on the conveyor 586 and be moved to out-feed conveyor section 584. In addition to the chute 596 leading to the automated carrier 598, the system of Figure 69 includes a chute 593 with a pair of bomb-bay doors 597 (as

discussed above with reference to Figures 49 – 51B) for selectively providing an object either to the conveyor 594 or dropping an object onto conveyor 595 that is adjacent conveyor 594.

The object processing system may include a plurality of stations as discussed above, and the induction filtering may direct different objects to the different stations based on a variety of object characteristics and end effector characteristics (e.g., knowing which end effectors are better suited for handling which objects). The ability to provide objects from infeed conveyors to a wide variety of processing systems provides significant flexibility, and the ability to provide objects to automated carriers provides further flexibility in object processing. Figure 70, for example, shows an object processing system 650 that includes multiple workstations 652, 654, 656 that receive objects via diverters 660, 662, 670, 672, 680, 682 under control of the one or more processing systems 690. Workstation 652, may for example, be well suited for using an articulated arm 664 to move bags for destination locations 666, and workstation 654 may, for example, be better suited for using an articulated arm to move cylinders to destination locations 676. Another workstation 656, may for example, include a human worker 684 for moving objects to destination locations 686 that are not easily processed by any articulated arms.

Object processing systems for use with induction filtering systems and methods of various embodiments of the invention may be any of a wide variety of object processing systems such as sortation systems, automated storage and retrieval systems, and distribution and redistribution systems. For example, in accordance with further embodiments, the invention provides systems that are capable of automating the outbound process of a processing system. The system may include one or more automated picking stations 700 (as shown in Figure 71) and manual picking stations 800 (as shown in Figure 72) that are supplied with containers by a fleet of mobile carriers that traverse a smart flooring structure formed of track segments as discussed above. The carriers may carry bins that can store objects. The system may provide a novel goods-to-picker system that uses a fleet of small mobile carriers to carry individual inventory totes and outbound containers to and from picking stations.

In accordance with an embodiment of the system includes an automated picking station that picks caches from inventory totes and loads them into outbound containers. The system involves together machine vision, task and motion planning, control, error detection and recovery, and artificial intelligence grounded in a sensor-enabled, hardware platform to enable a real-time and robust solution for singulating items out of cluttered containers.

With reference to Figure 71, the automated picking system 700 perceives the contents of the containers using a multi-modal perception unit and uses a robotic arm equipped with an automated programmable motion gripper and integrated software in processing system 720 to

pick eaches from homogeneous inventory totes and place them into heterogeneous outbound containers. These elements are co-located in a work cell that meets industry standard safety requirements and interfaces with track system to keep the automated picking system fed with a continual supply of inventory totes and outbound containers.

In particular, the system 700 includes an array 702 of track elements 704 as discussed above, as well as automated carriers 706 that ride on the track elements 704 as discussed above. One or more overhead perception units 708 (e.g., cameras or scanners) acquire perception data regarding objects in bins or totes 710, as well as perception data regarding locations of destination boxes 712. A programmable motion device such as a robotic system 714 picks an object from the bin or tote 710, and places it in the adjacent box 712. One or both of the units 710, 712 are then moved automatically back into the grid, and one or two new such units are moved into position adjacent the robotic system. Meanwhile, the robotic system is employed to process another pair of adjacent units (again, a bin or tote 710 and a box 712) on the other side of the robotic system 714. The robotic system therefore processes a pair of processing units on one side, then switches sides while the first side is being replenished. This way, the system 700 need not wait for a new pair of object processing units to be presented to the robotic system. The array 702 of track elements 704 may also include shelf stations 716 at which mobile units 706 may park or pick up either bins / totes 710 and boxes 712. The system operates under the control, for example, of a computer processor 720.

The manual pick station system is a goods-to-person pick station supplied by mobile automated movement carriers on track systems as discussed above. The system has the same form and function as the automated picking station in that both are supplied by the same carriers, both are connected to the same track system grid, and both transfer eaches from an inventory tote to an outbound container. The manual system 800 (as shown in Figure 72) relies on a manual team member to perform the picking operation.

Also, the manual system raises carriers to an ergonomic height (e.g. via ramps), ensures safe access to containers on the carriers, and includes a monitor interface (HMI) to direct the team member's activities. The identity of the SKU and the quantity of items to pick are displayed on an HMI. The team member must scan each unit's UPC to verify the pick is complete using a presentation scanner or handheld barcode scanner. Once all picks between a pair of containers are complete, the team member presses a button to mark completion.

In accordance with this embodiment (and/or in conjunction with a system that includes an AutoPick system as discussed above), a system 800 of Figure 72 may include an array 802 of track elements 804 that are provided on planer surfaces 806 as well as inclined surfaces 808

leading to further planar surfaces. The system 800 may also include visual data screens 809 that provide visual data to a human sorter, informing the human sorter of what goods are to be moved from totes or bins 810 to destination boxes 812. The system operates under the control, for example, of a computer processor 820.

While the bulk of the overall system's picking throughput is expected to be handled by automated picking systems, manual picking systems provide the carrier and track system the ability to (a) rapidly scale to meet an unplanned increase in demand; (b) handle goods that are not yet amenable to automation; and (c) serve as a QA, problem solving, or inventory consolidation station within the overall distribution system. The system therefore, provides significant scaling and trouble-shooting capabilities in that a human sorted may be easily added to an otherwise fully automated system. As soon as a manual picking system is enabled (occupied by a sorter), the system will begin to send totes or bins 810 and boxes 812 to the manual picking station. Automated picking stations and manual picking stations are designed to occupy the same footprint, so a manual picking station may later be replaced with an automated picking station with minimal modifications to the rest of the system.

Again, a carrier is a small mobile robot that can interchangeably carry an inventory tote, outbound container, or a vendor case pack. These carriers can remove or replace a container from or onto a storage fixture using a simple linkage mechanism. Since a carrier only carries one container at a time, it can be smaller, lighter, and draw less power than a larger robot, while being much faster. Since the carriers drive on a smart tile flooring, they have lessened sensing, computation, and precision requirements than mobile robots operating on bare floor. These features improve cost to performance metrics.

All carriers run on the same shared roadway of track sections as independent container-delivery agents. The carriers can move forward, backward, left or right to drive around each other and reach any location in the system. This flexibility allows the carriers to serve multiple roles in the system by transporting (a) inventory totes to picking stations, (b) outbound containers to picking stations, (c) inventory totes to and from bulk storage, (d) full outbound containers to discharge lanes, and (e) empty outbound containers into the system. Additionally, the carriers may be added incrementally as needed to scale with facility growth.

The track floor modules are standard-sized, modular, and connectable floor sections. These tiles provide navigation and a standard driving surface for the carriers and may act as a storage area for containers. The modules are connected to robotic pick cells, induction stations from bulk storage, and discharge stations near loading docks. The modules eliminate the need

of other forms of automation, e.g. conveyors, for the transportation of containers within the system.

As shown at 900 in Figure 73, the system may be scaled up to include a much larger array of track modules 902, and many processing stations 904 that may, for example, be any of inventory in-feed stations, empty outbound vessel in-feed stations, automated and manual processing stations, and outbound stations as discussed above. The system operates under the control, for example, of a computer processor 906.

Those skilled in the art will appreciate that numerous modifications and variations may be made to the above disclosed embodiments without departing from the spirit and scope of the present invention.

What is claimed is:

CLAIMS

1. An induction system for filtering the induction of objects to a plurality of object processing systems, said induction system comprising:
 - an evaluation means for evaluating at least one characteristic of an object; and
 - routing means for routing the object in one of a plurality of directions responsive to the evaluated characteristic, at least one of the plurality of directions leading to a selected one of the plurality of object processing systems.
2. The induction system as claimed in claim 1, wherein the evaluation means determines any of a weight, mass, volume or density of the object.
3. The induction system as claimed in claim 1 or claim 2, wherein the evaluation means includes an elevated roller.
4. The induction system as claimed in claim 3, wherein the elevated roller is adapted to rotate faster than a transport conveyance system preceding the elevated roller.
5. The induction system as claimed in claim 3 or claim 4, wherein the elevated roller is mounted on one of a load cell or a force torque sensor.
6. The induction system as claimed in any of claims 2 – 5, wherein the evaluation means includes at least one load cell or torque force sensor.
7. The induction system as claimed in claim 5 or claim 6, wherein the load cell or force torque sensor is provided in a conveyor system.
8. The induction system as claimed in any of claims 1 – 7, wherein the plurality of directions includes a path that leads to a processing station for processing non-rigid objects.
9. The induction system as claimed in any of claims 1 – 8, wherein the routing means includes the application of any of vacuum and forced air to the object.
10. The induction system as claimed in any of claims 1 – 9, wherein the routing means includes a drop mechanism for dropping an object through doors.
11. The induction system as claimed in any of claims 1 – 10, wherein the routing means includes a three-way conveyor for moving an object in one of three selectable directions.

12. The induction system as claimed in any of claims 1 – 11, wherein the plurality of directions lead to the plurality of object processing stations in series.
13. The induction system as claimed in any of claims 1 – 12, wherein the plurality of directions lead to the plurality of object processing stations in parallel.
14. The induction system as claimed in any of claims 1 – 13, wherein the plurality of object processing stations include automated object processing stations and manual object processing stations.
15. An induction system for filtering the induction of objects to any of a plurality of object processing stations, said induction system comprising:
 - discrimination means for routing the object in one of a plurality of directions responsive to a discriminating characteristic of the object, at least one of the plurality of directions leading to a selected one of the object processing stations.
16. The induction system as claimed in claim 15, wherein the discrimination means determines any of a weight, mass, volume or density of the object.
17. The induction system as claimed in claim 15 or claim 16, wherein the discrimination means includes at least one load cell.
18. The induction system as claimed in claim 17, wherein the load cell is provided in a conveyor system.
19. The induction system as claimed in any of claims 15 – 18, wherein the plurality of directions includes a path that leads to a processing station for processing non-rigid objects.
20. The induction system as claimed in any of claims 15 – 19, wherein the discrimination means includes the application of any of vacuum and forced air to the object.
21. The induction system as claimed in any of claims 15 – 20, wherein the discrimination means includes a drop mechanism for dropping an object through doors.
22. The induction system as claimed in any of claims 15 – 21, wherein the discrimination means includes a three-way conveyor for moving an object in one of three selectable directions.

23. The induction system as claimed in any of claims 15 – 22, wherein the plurality of directions lead to a plurality of object processing stations.
24. The induction system as claimed in claim 23, wherein the plurality of object processing stations include automated object processing stations and manual object processing stations.
25. The induction system as claimed in any of claims 15 – 24, wherein the discrimination means includes an air-permeable conveyor and a vacuum source for providing vacuum through the conveyor as the conveyor reverses direction.
26. A method of distributing induction of objects to an object processing system including a plurality of object processing stations, said method comprising:
evaluating at least one characteristic of an object; and
routing the object in one of a plurality of directions responsive to the evaluated characteristic, at least one of the plurality of directions leading to a selected one of a plurality of object processing stations.
27. The method as claimed in claim 26, wherein the step of evaluating includes determining any of a weight, mass, volume or density of the object.
28. The method as claimed in claim 26 or claim 27, wherein the step of evaluating involves using at least one load cell.
29. The method as claimed in claim 28, wherein the load cell is provided in a conveyor system.
30. The method as claimed in any of claims 26 – 29, wherein the plurality of directions includes a path that leads to a processing station for processing non-rigid objects.
31. The method as claimed in any of claims 26 – 30, wherein the step of routing the object involves the application of any of vacuum and forced air to the object.
32. The method as claimed in any of claims 26 – 31, wherein the step of routing involves dropping an object through doors.
33. The method as claimed in any of claims 26 – 32, wherein the step of routing involves the use of a three-way conveyor for moving an object in one of three selectable directions.

34. The method as claimed in any of claims 26 – 33, wherein the plurality of directions lead to a plurality of object processing stations.

35. The method as claimed in claim 34, wherein the plurality of object processing stations include automated object processing stations and manual object processing stations.

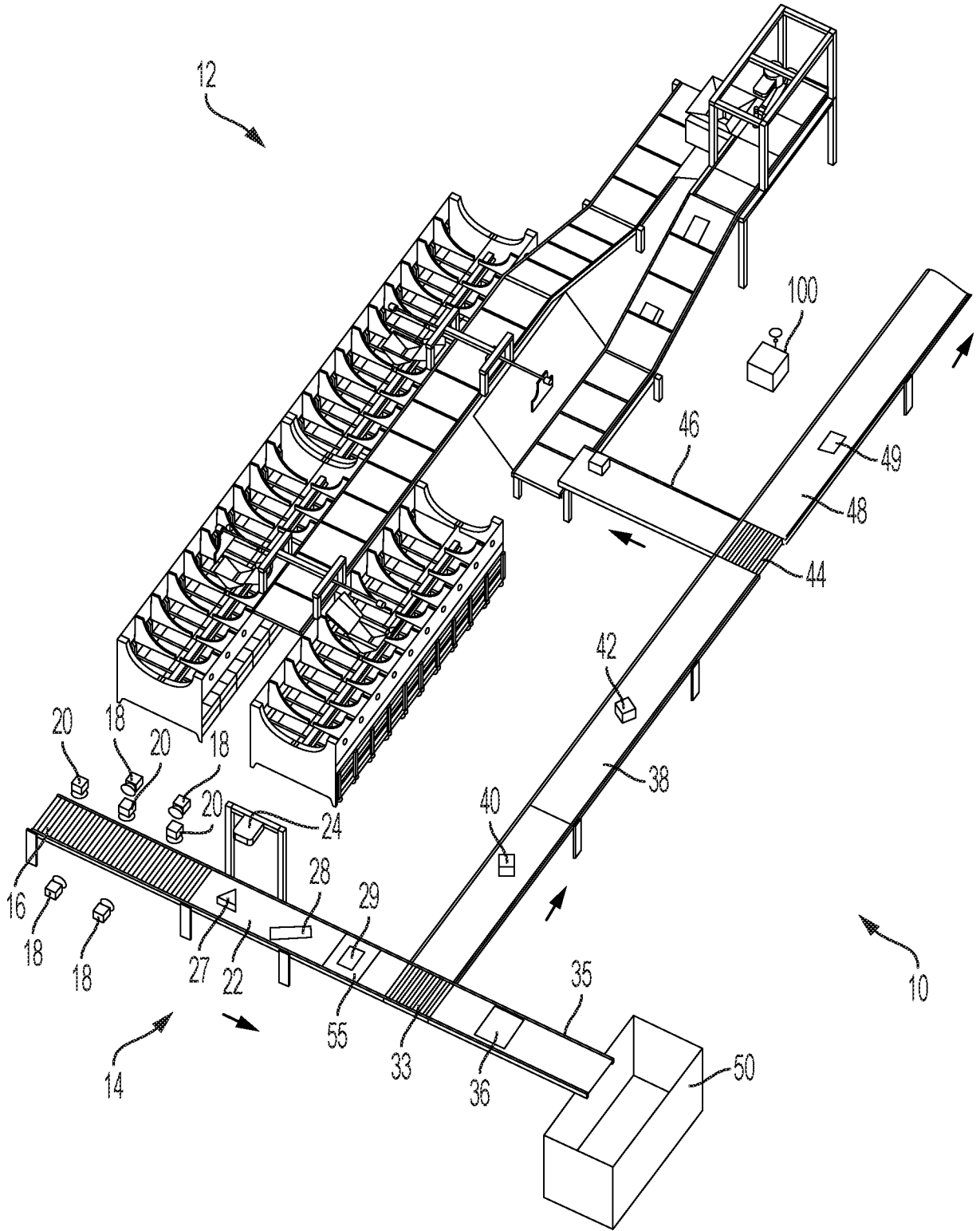

FIG. 1

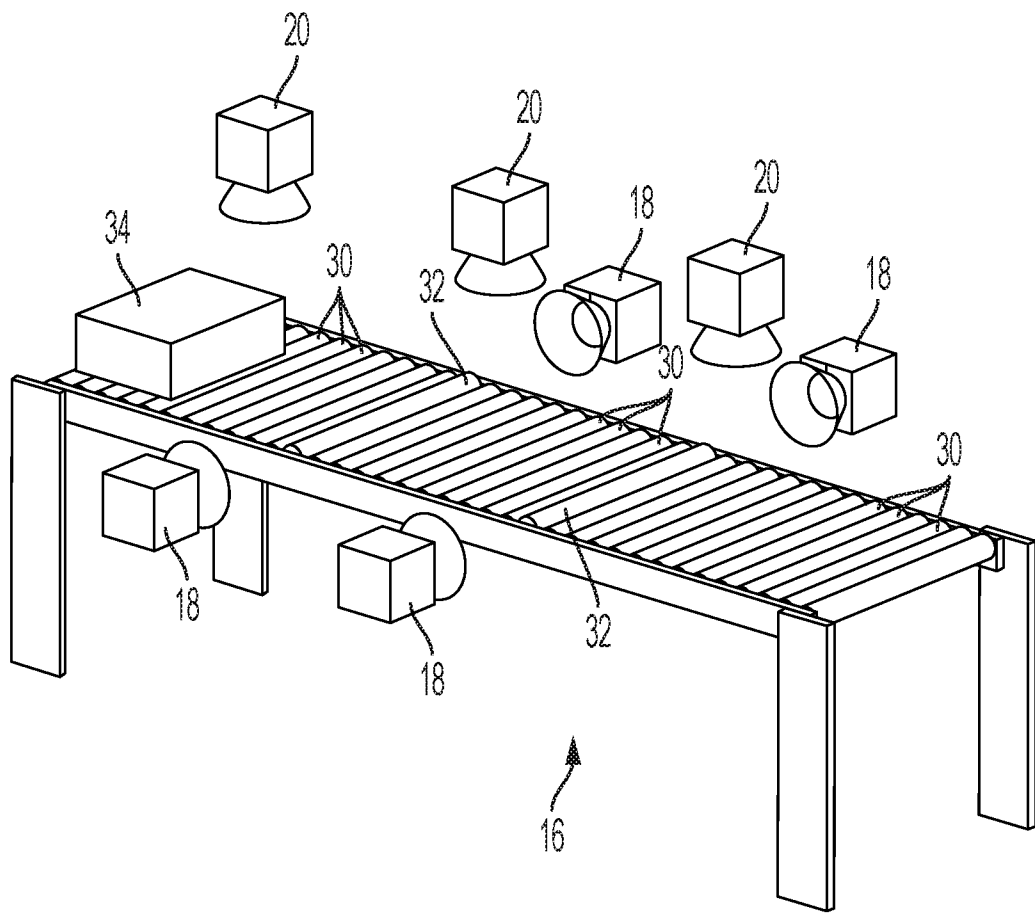

FIG. 2

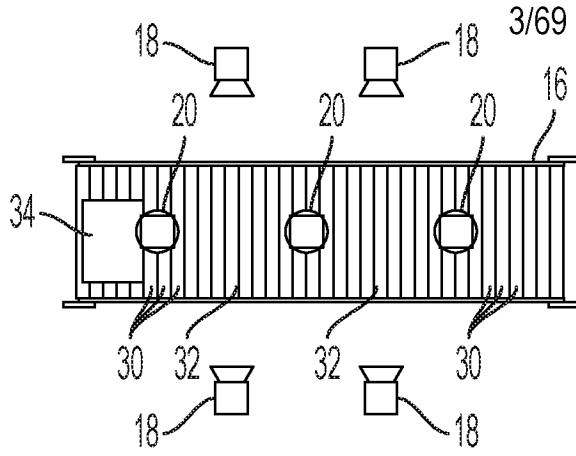

FIG. 3A

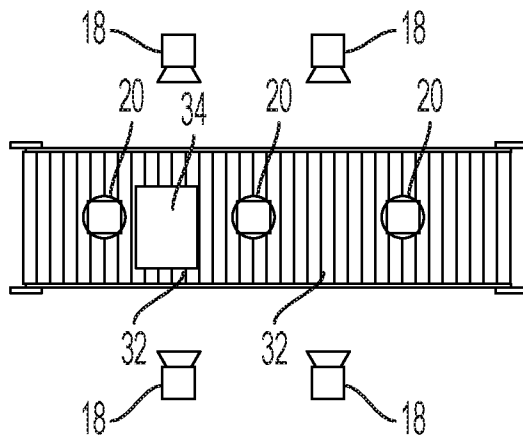

FIG. 3B

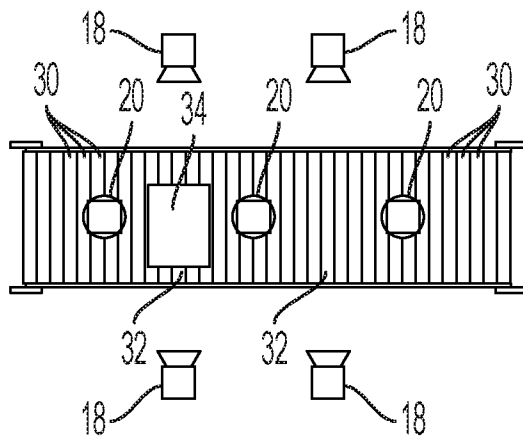

FIG. 3C

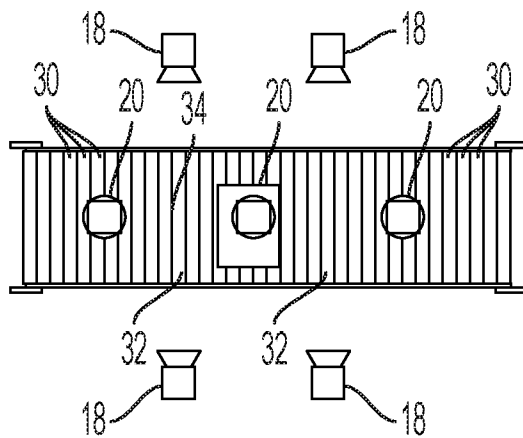

FIG. 3D

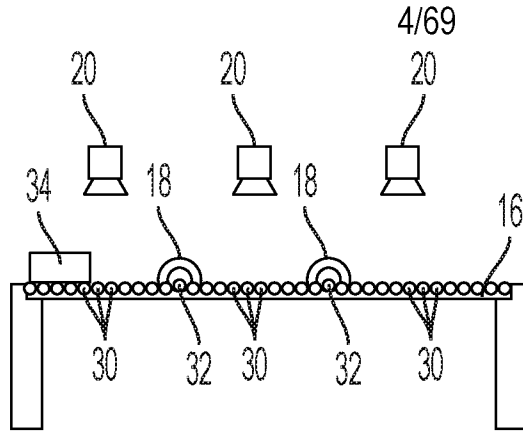

FIG. 4A

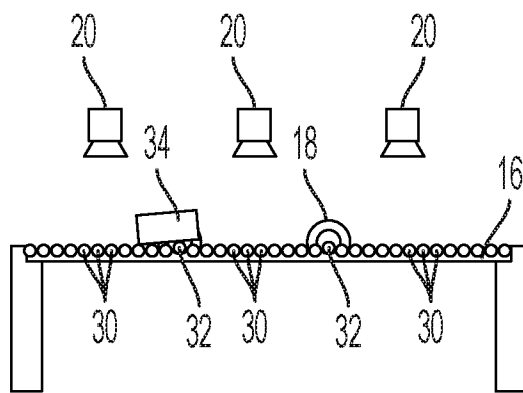

FIG. 4B

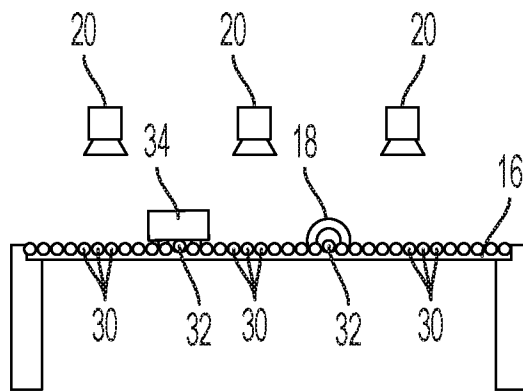

FIG. 4C

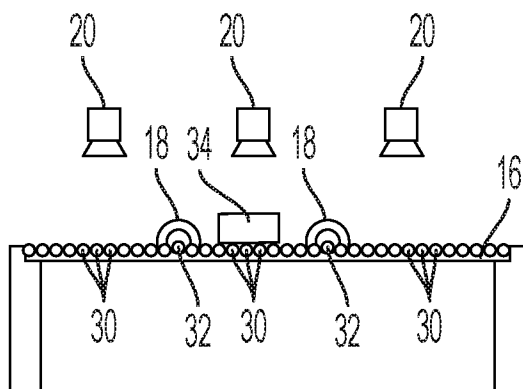

FIG. 4D

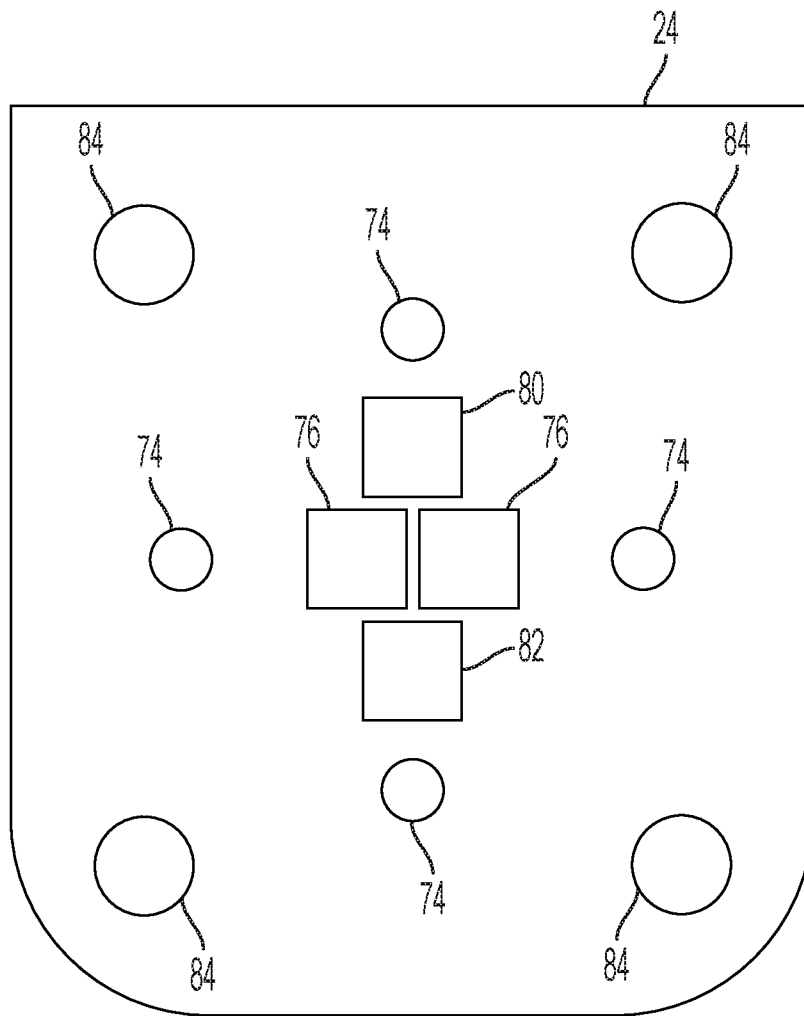

FIG. 5

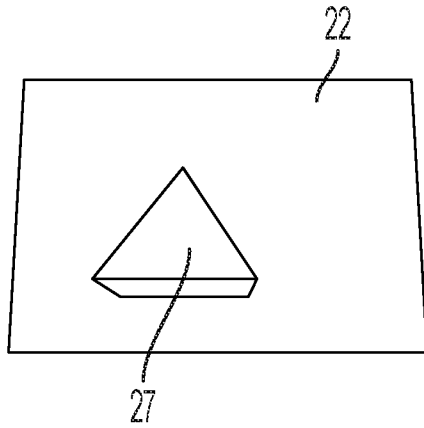

FIG. 6A

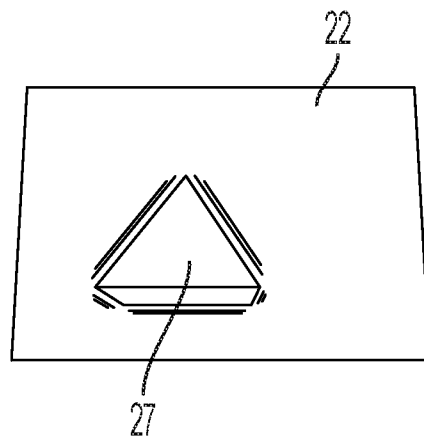

FIG. 6B

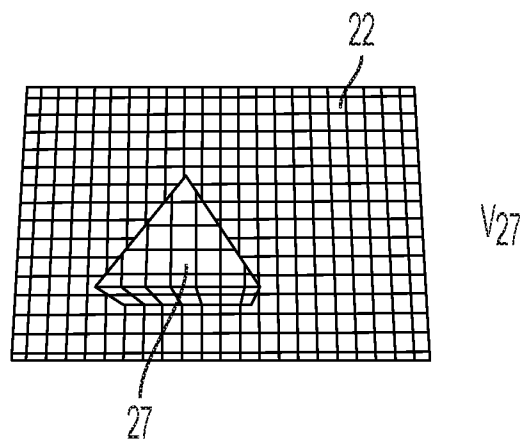

FIG. 6C

7/69

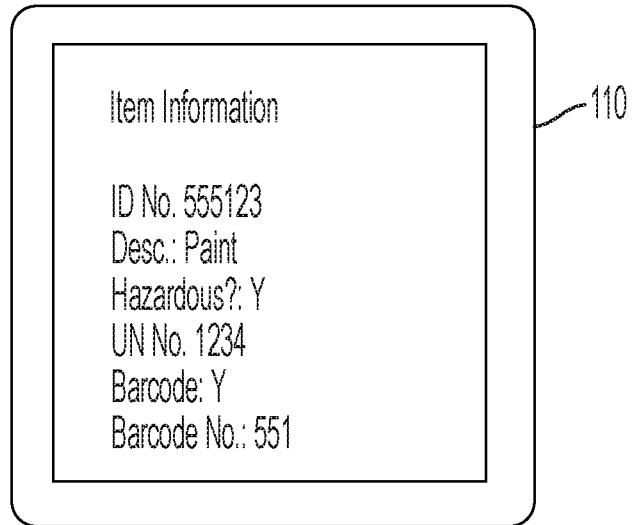

FIG. 7

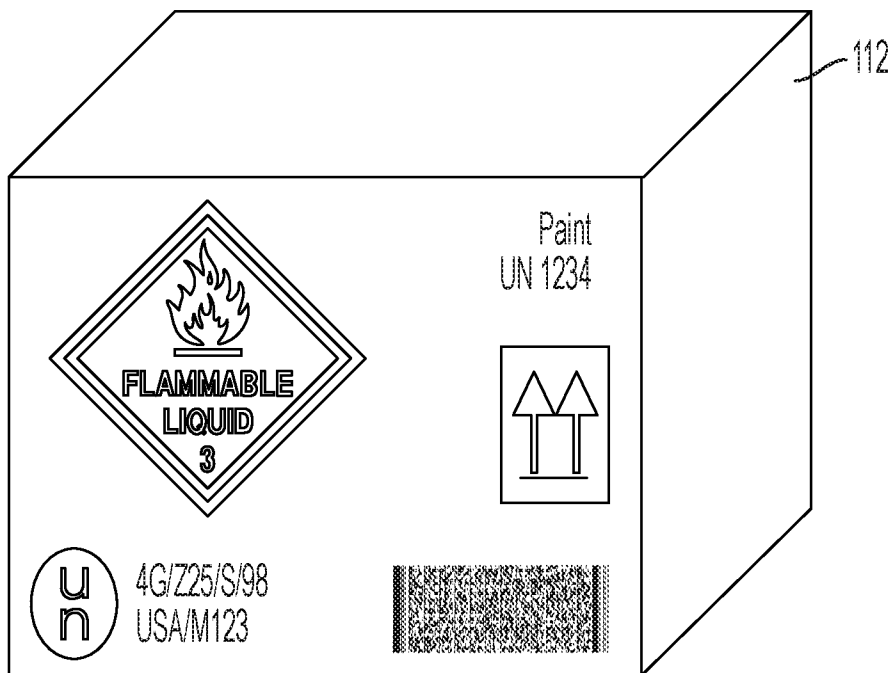

FIG. 8

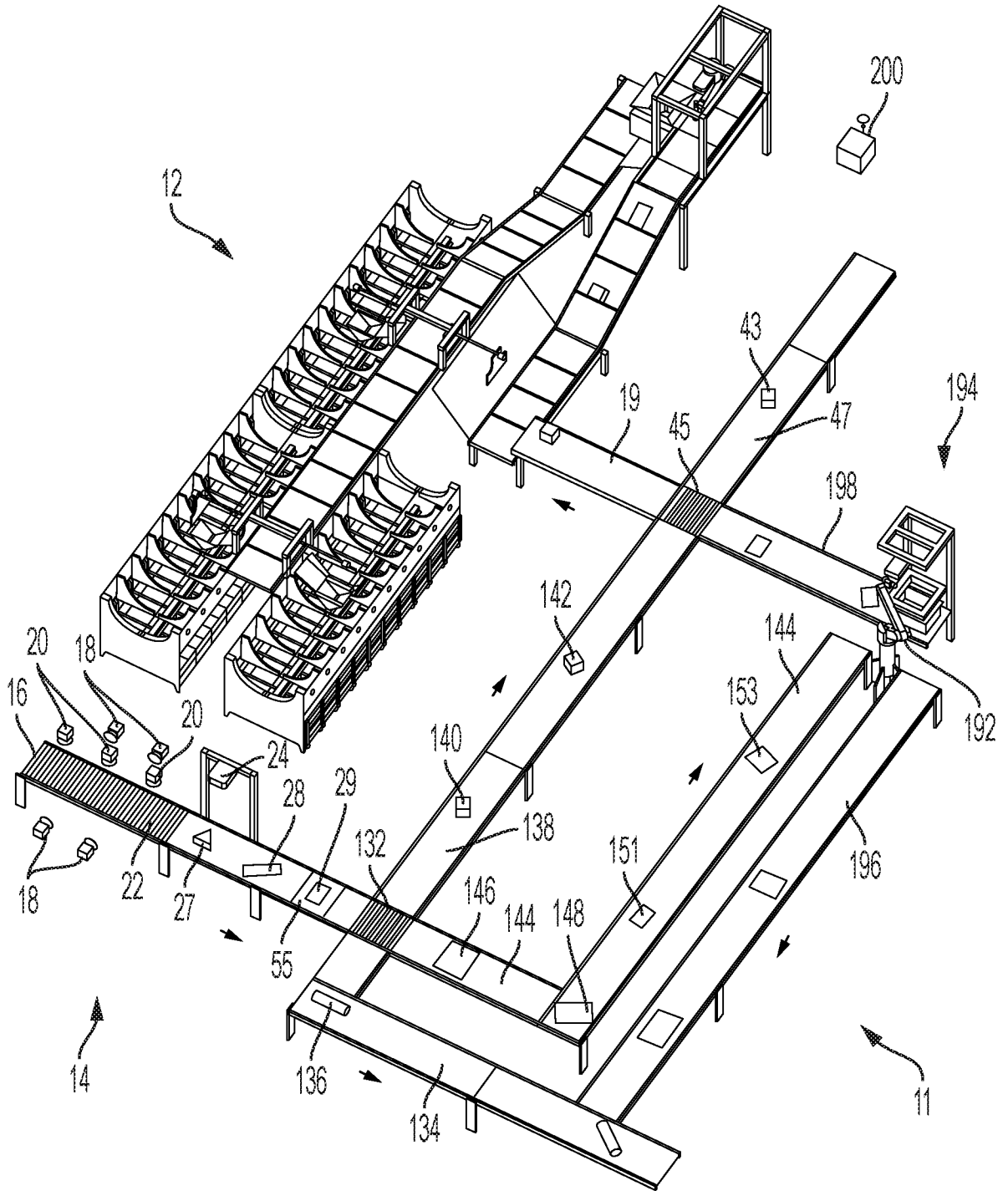

FIG. 9

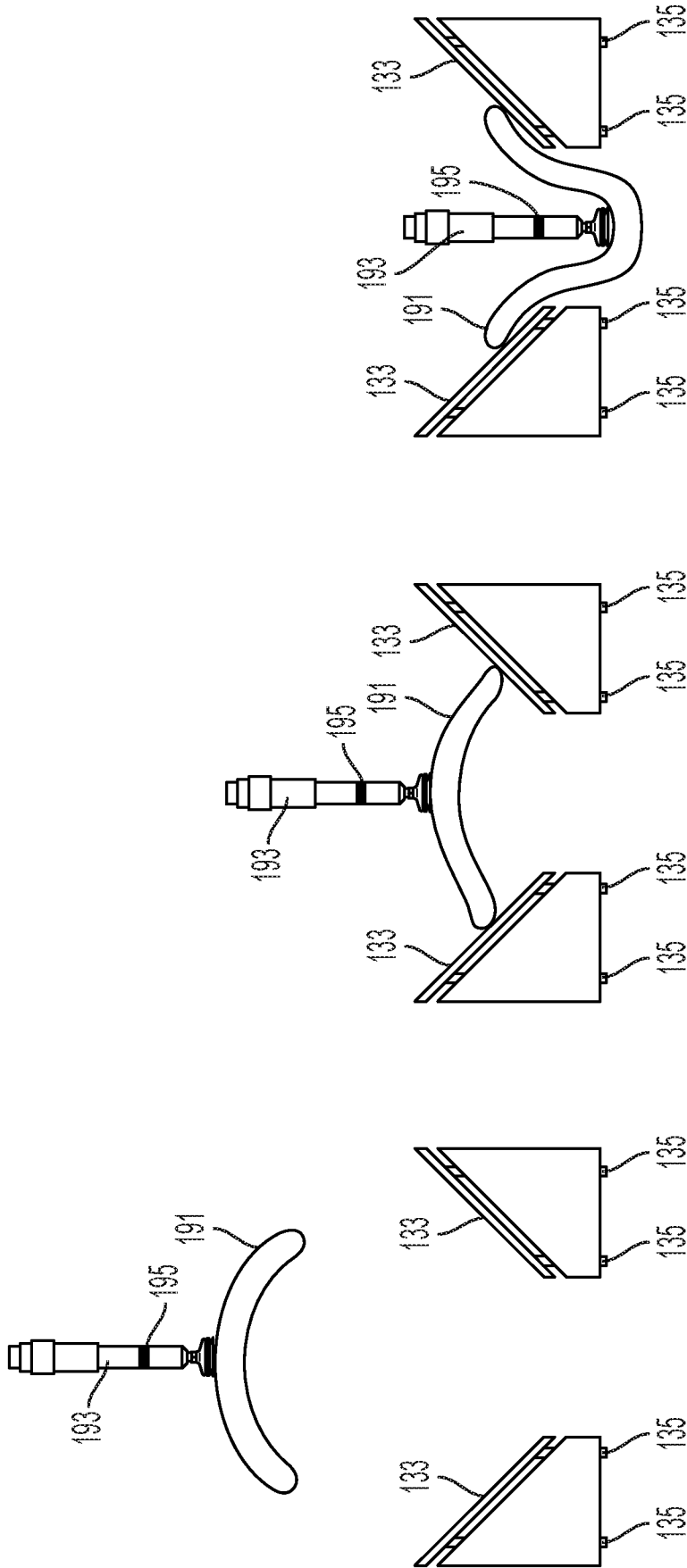

FIG. 10C

FIG. 10B

FIG. 10A

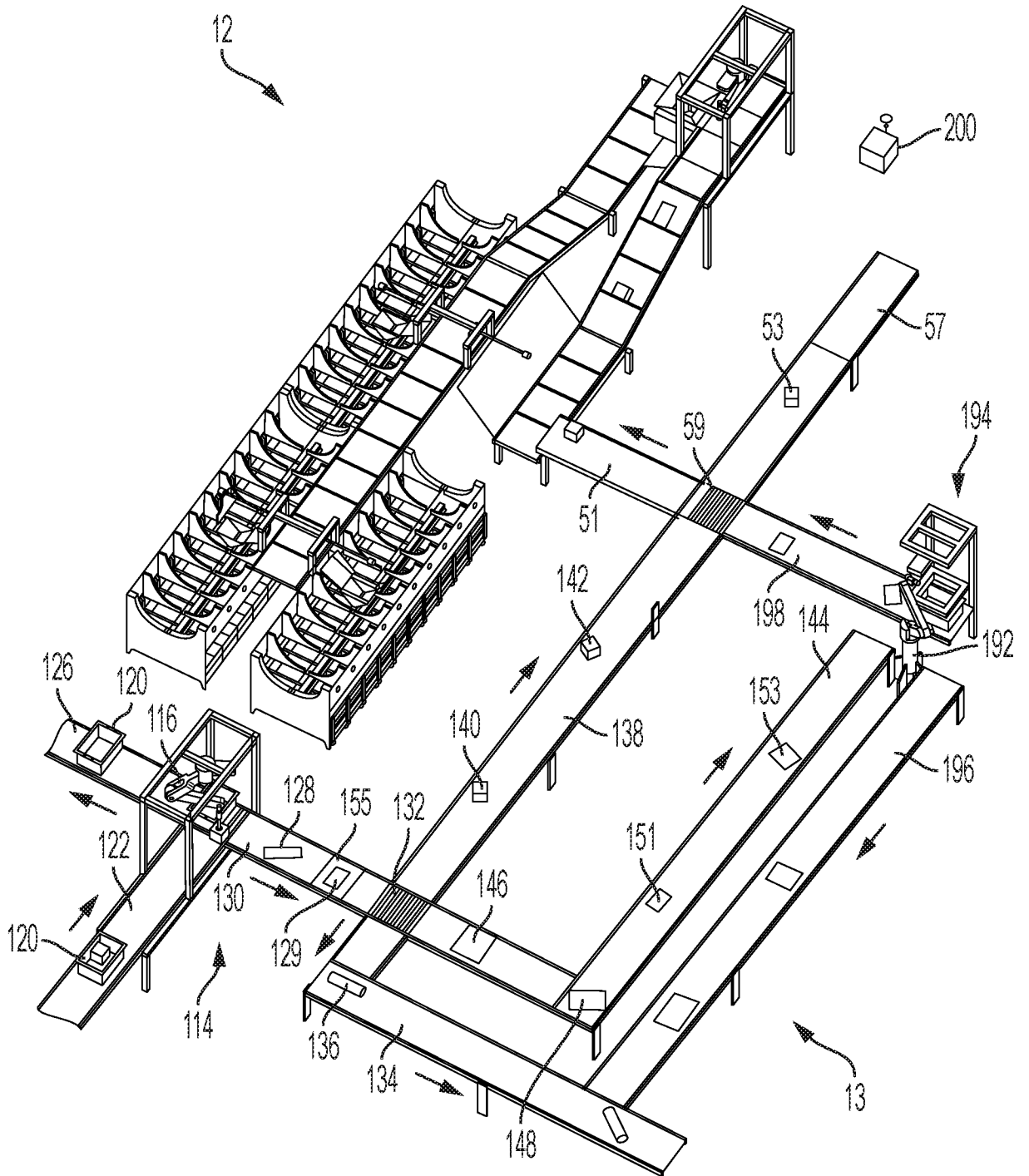

FIG. 11

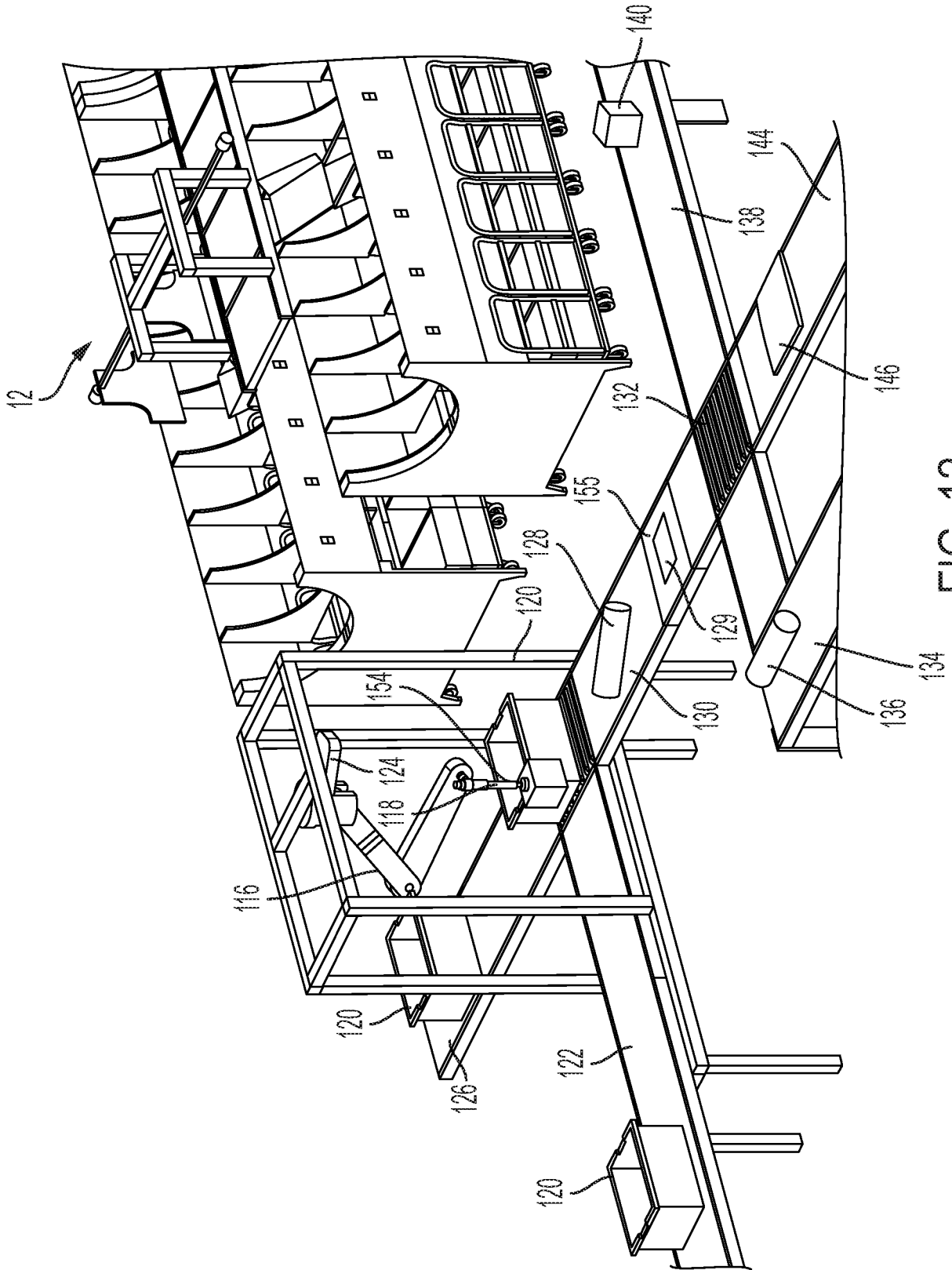

FIG. 12

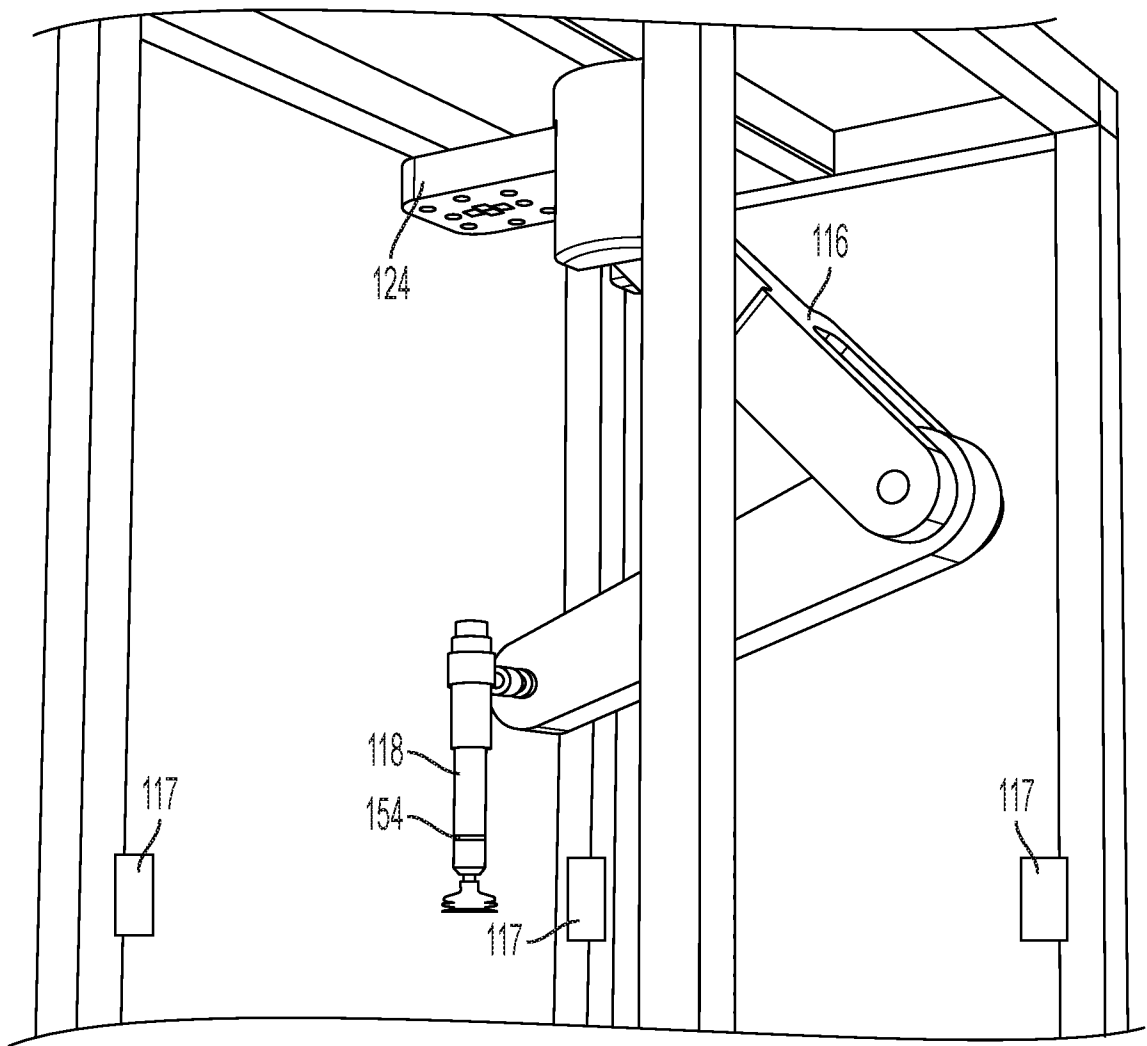

FIG. 13

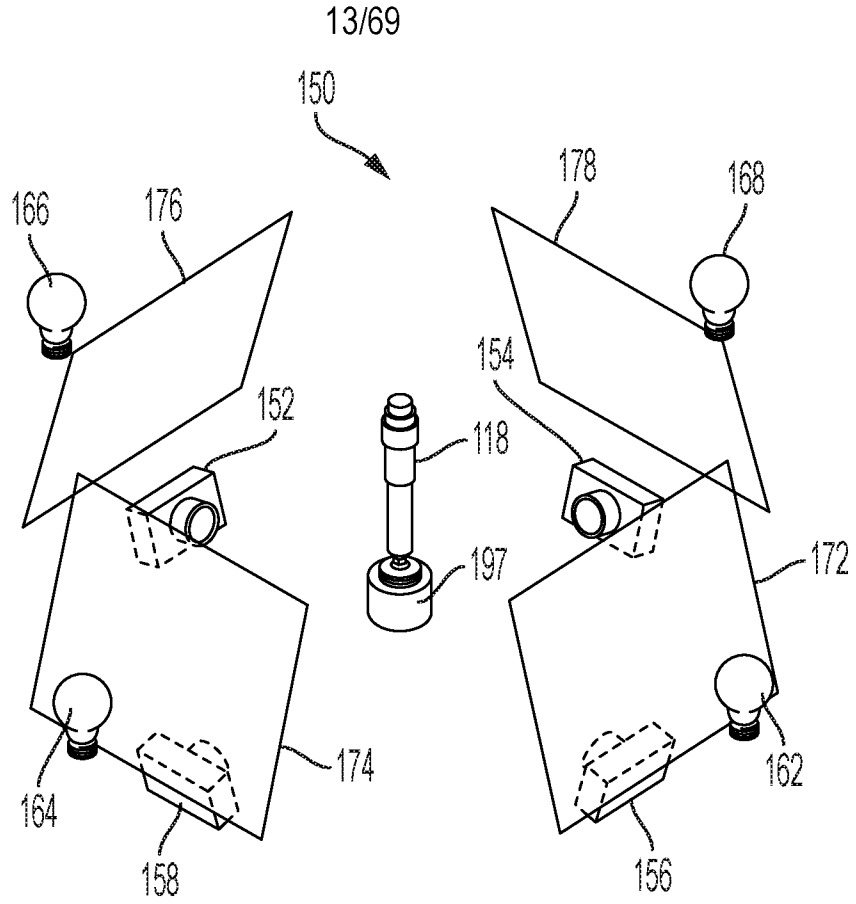

FIG. 14

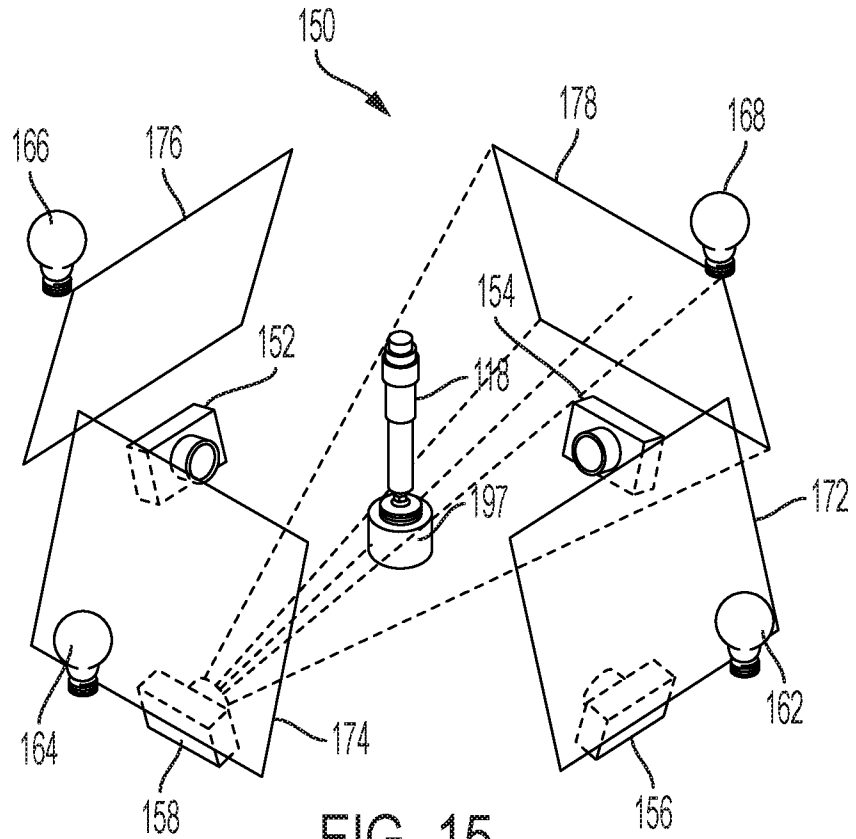

FIG. 15

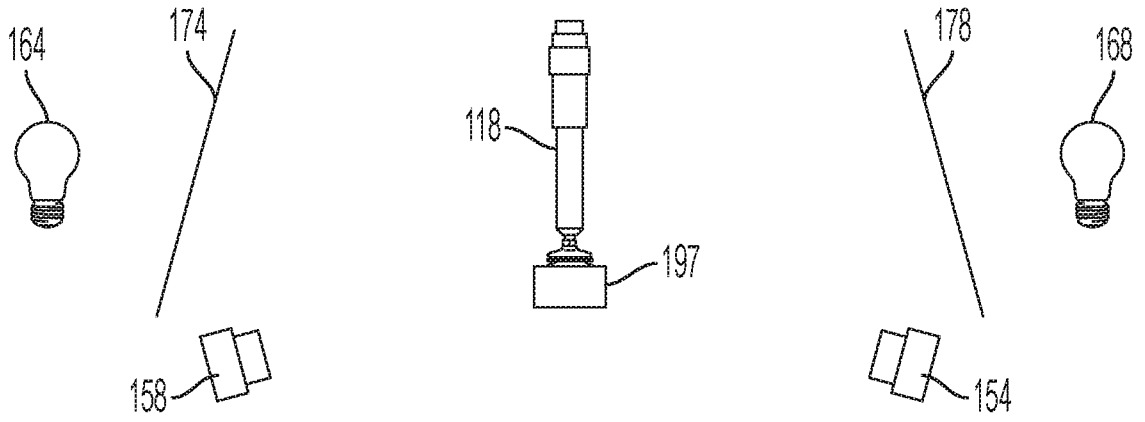

FIG. 16

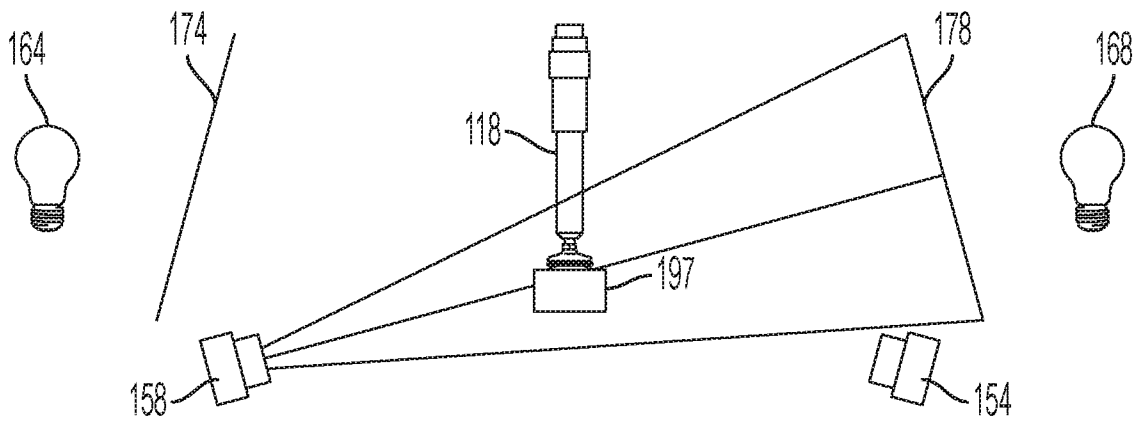

FIG. 17

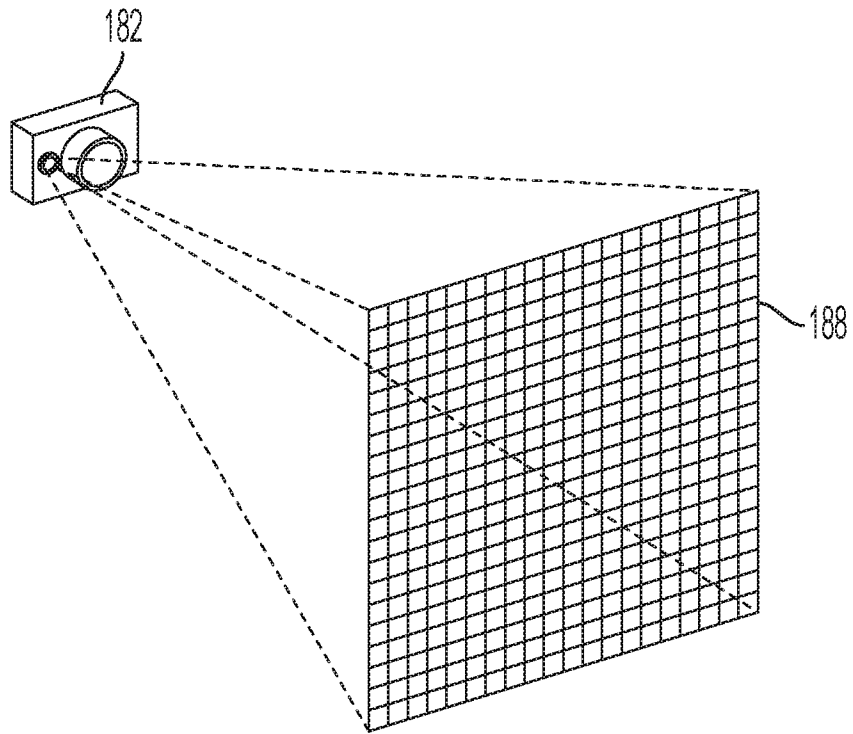

FIG. 18

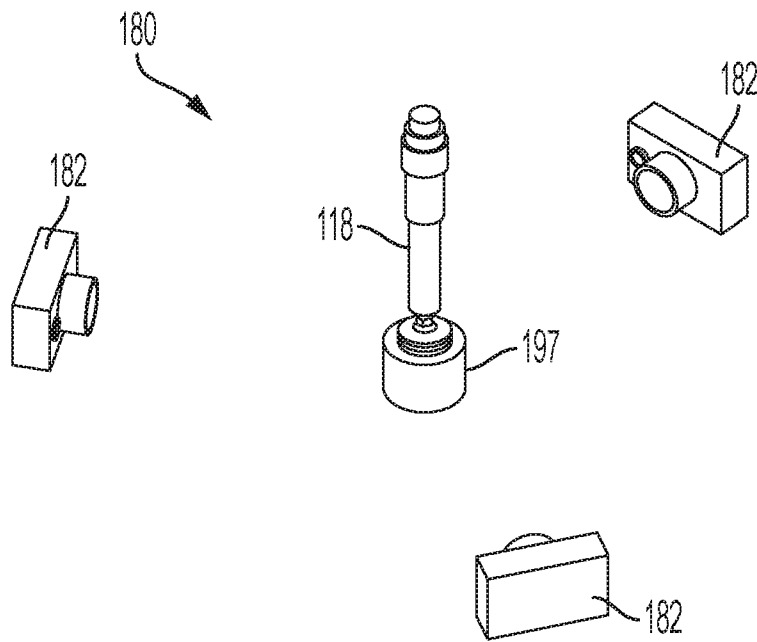

FIG. 19

16/69

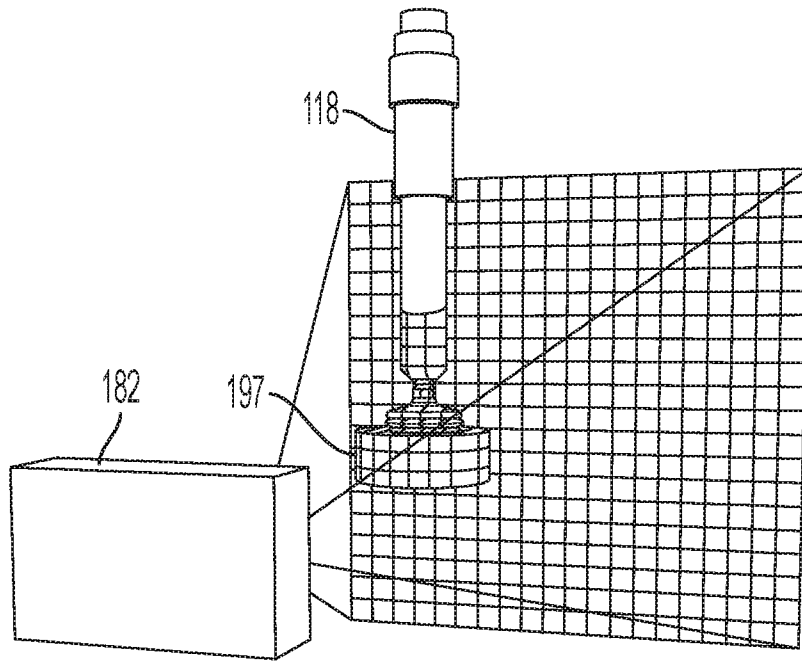

FIG. 20

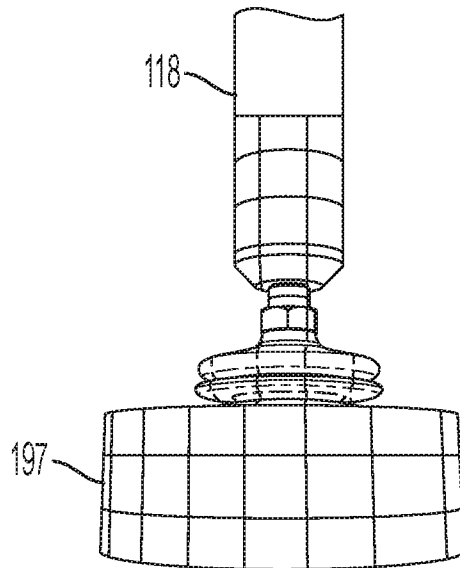

FIG. 21

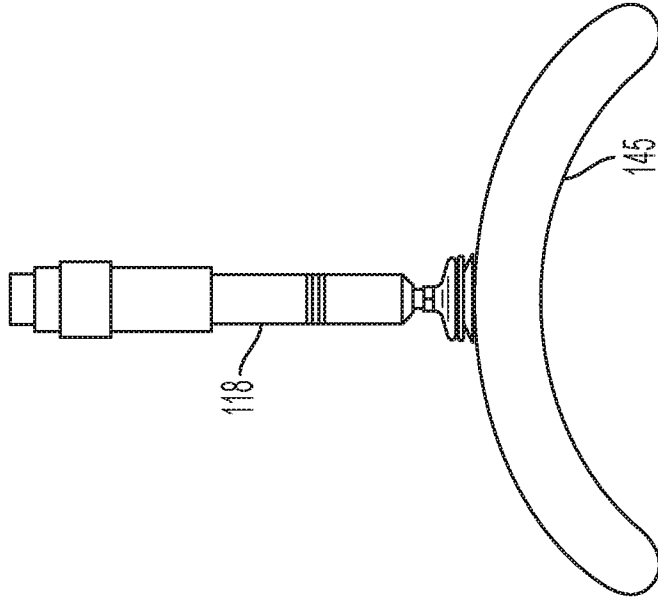

FIG. 22B

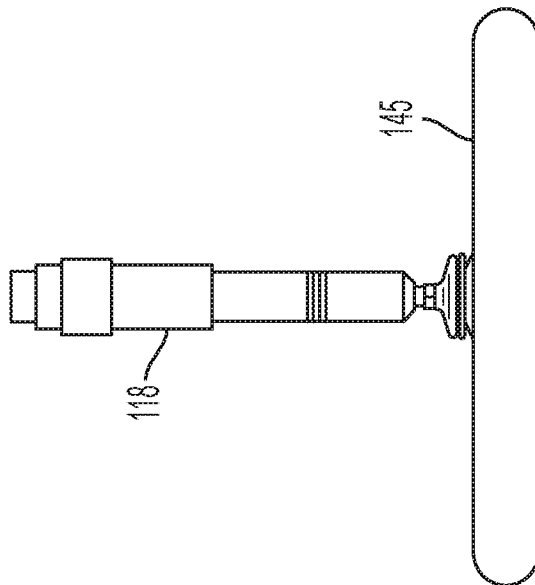

FIG. 22A

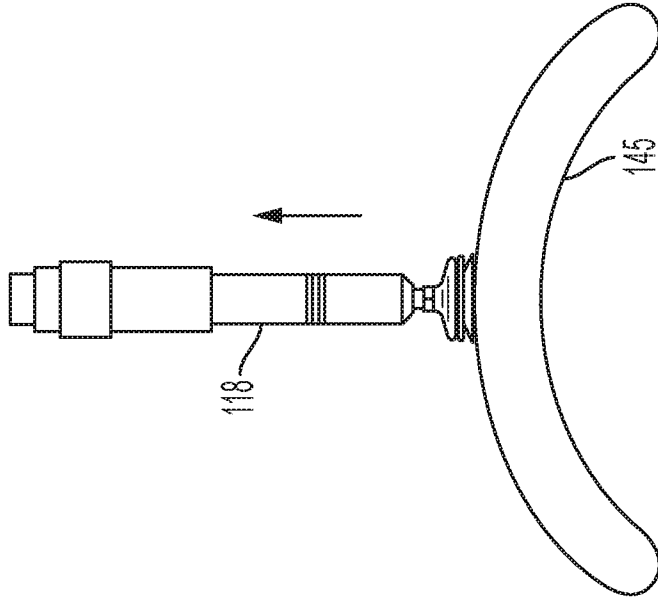

FIG. 22D

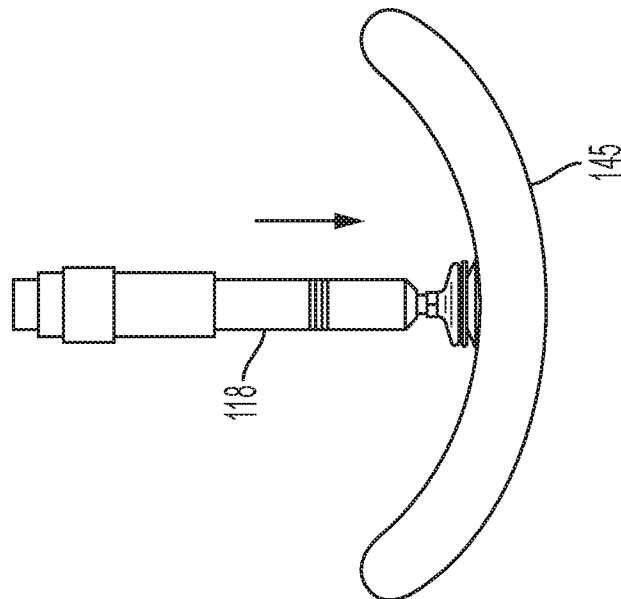

FIG. 22C

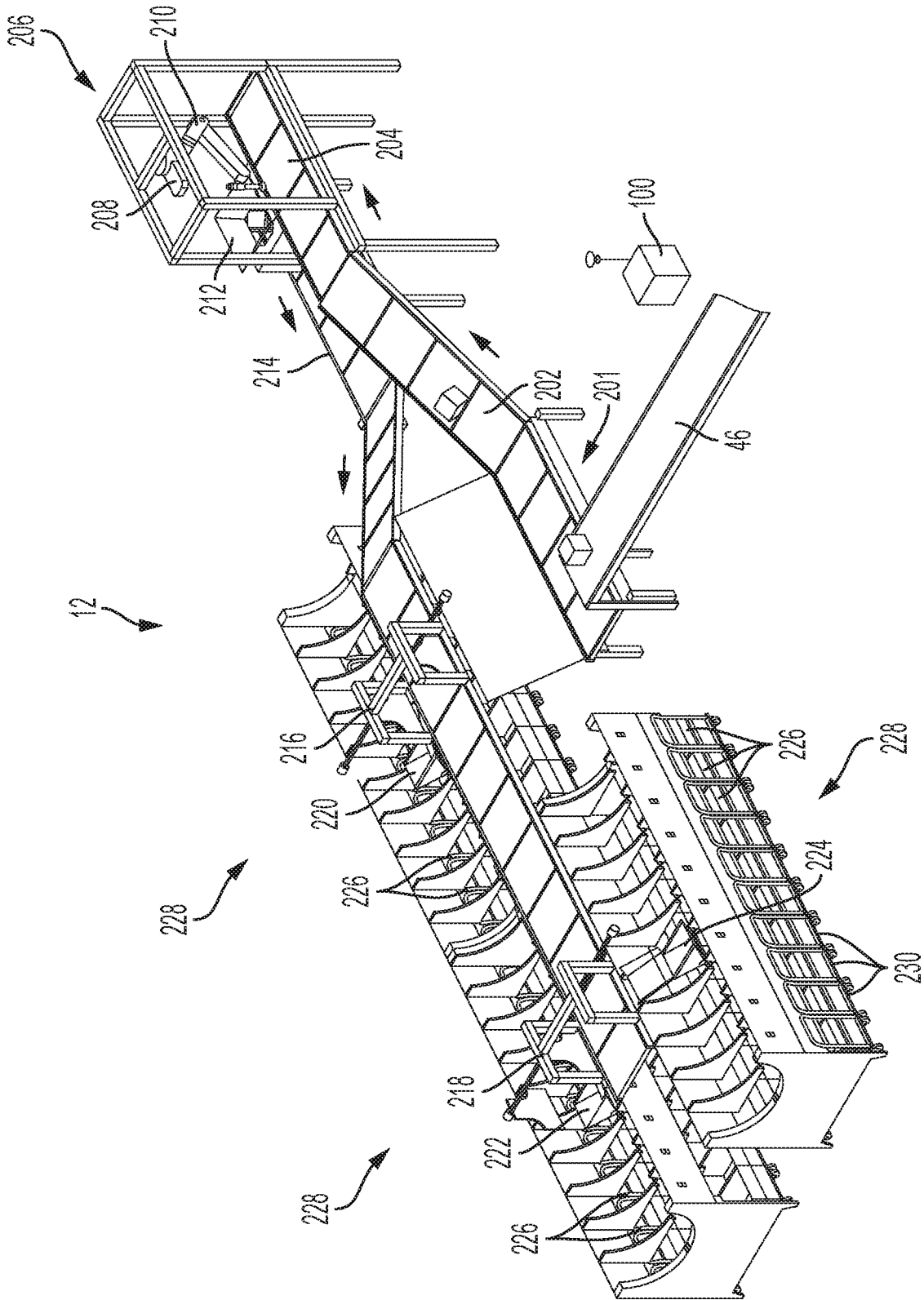

FIG. 23

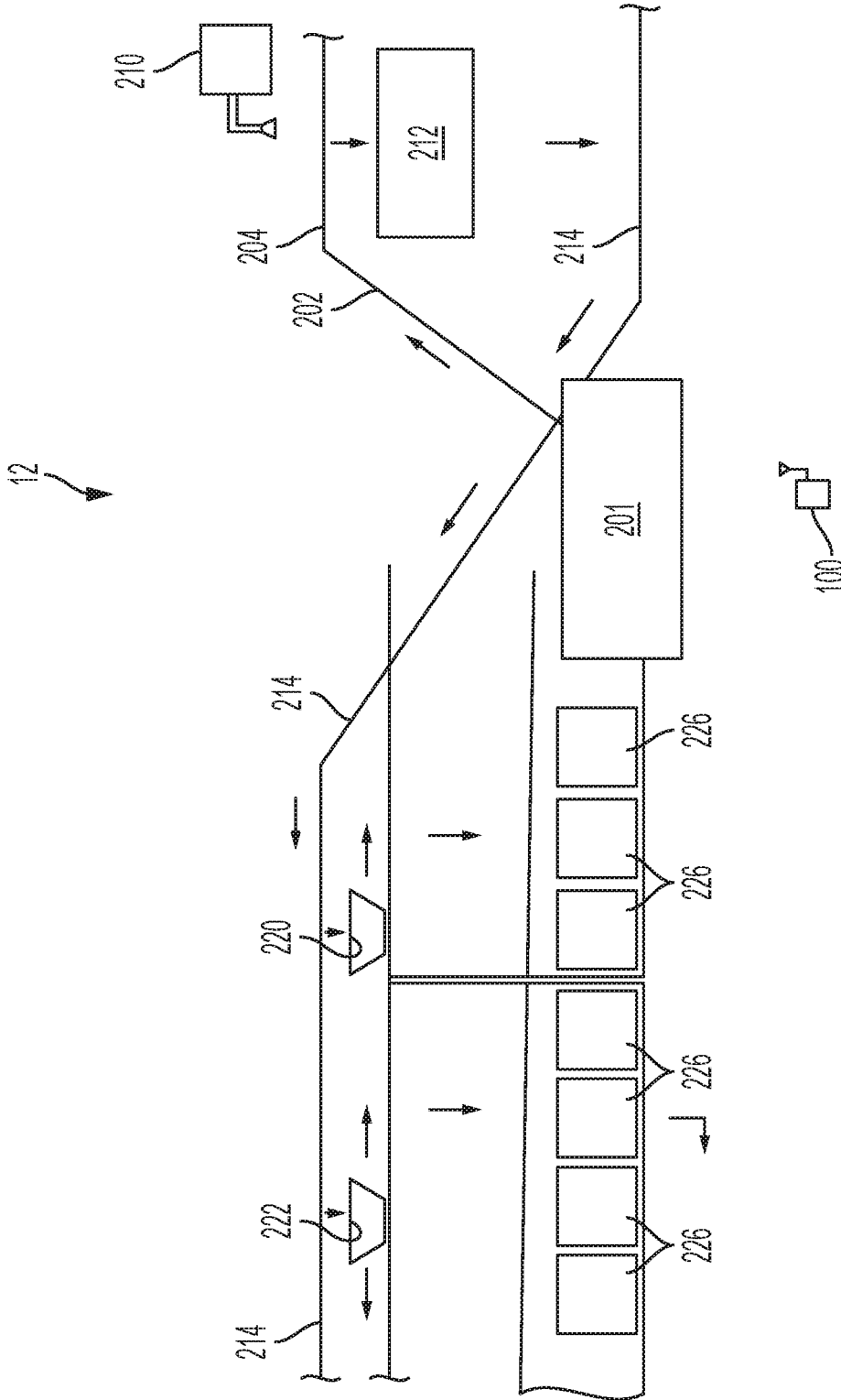

FIG. 24

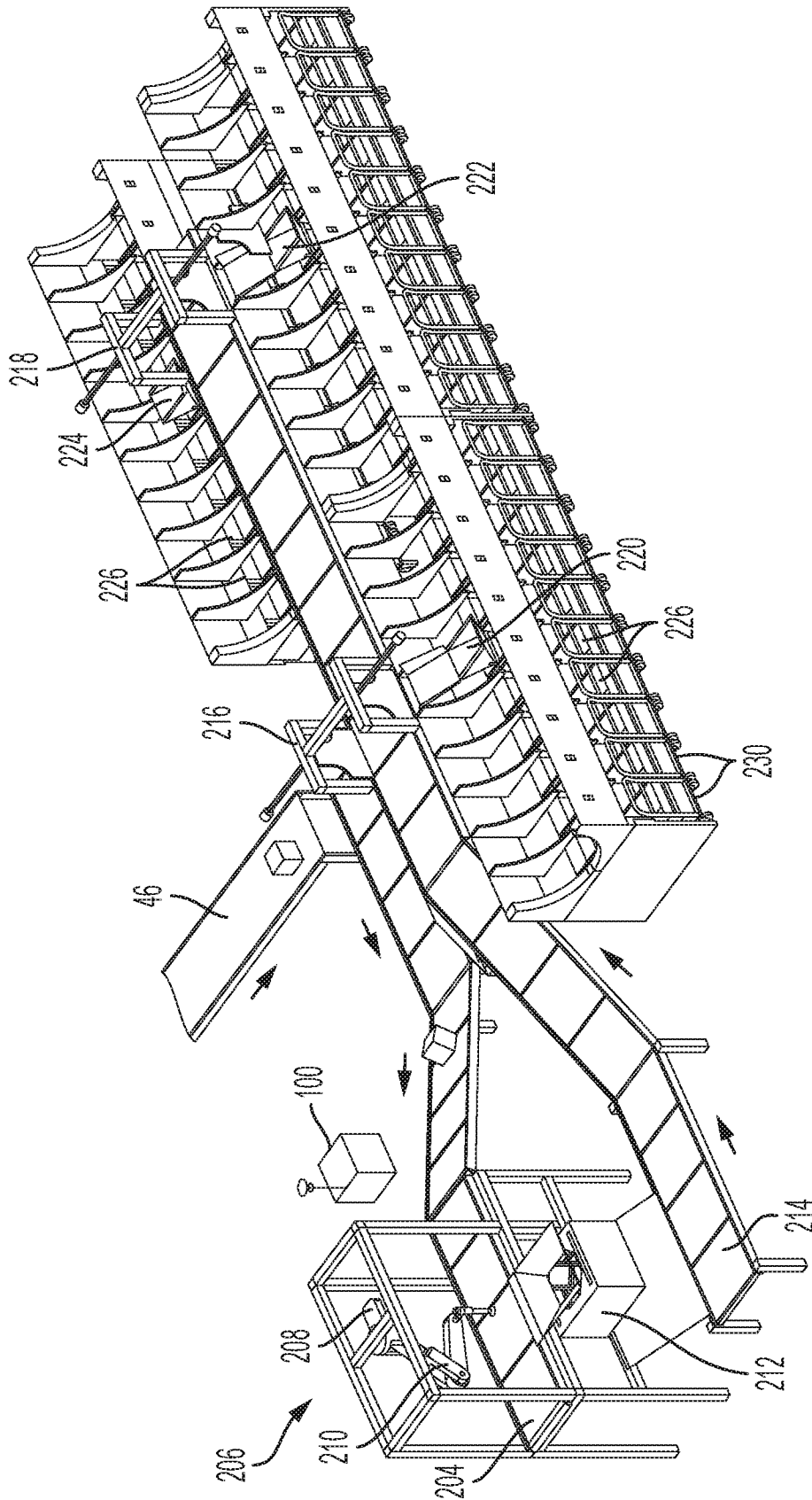

FIG. 25

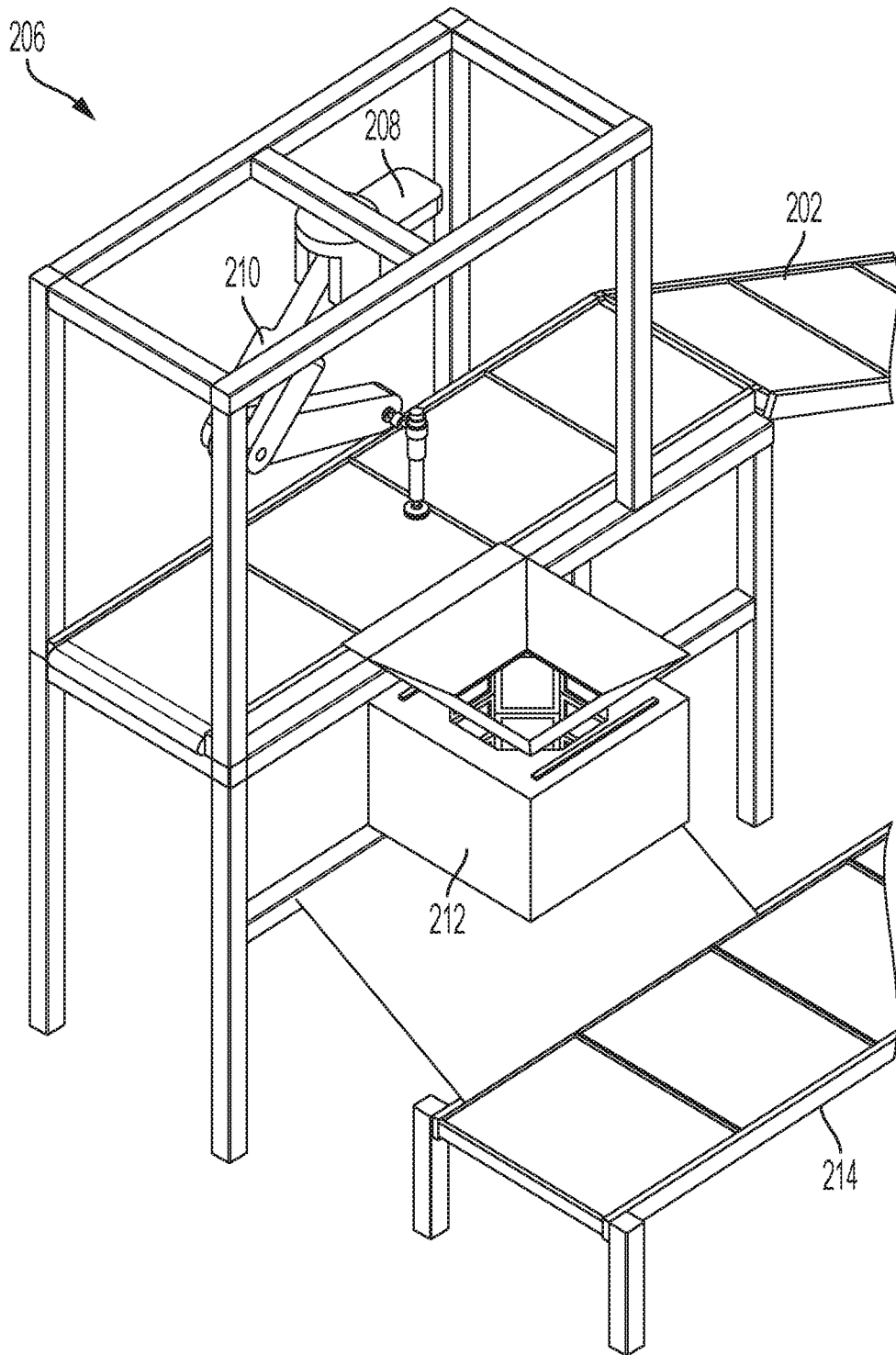

FIG. 26

24/69

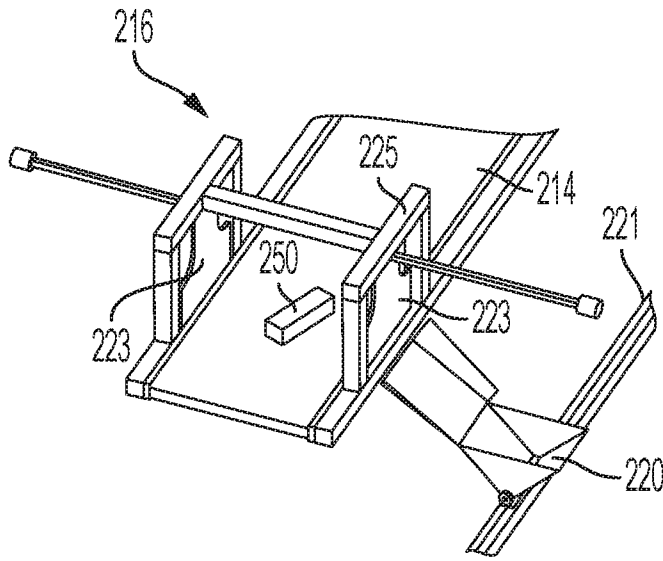

FIG. 28A

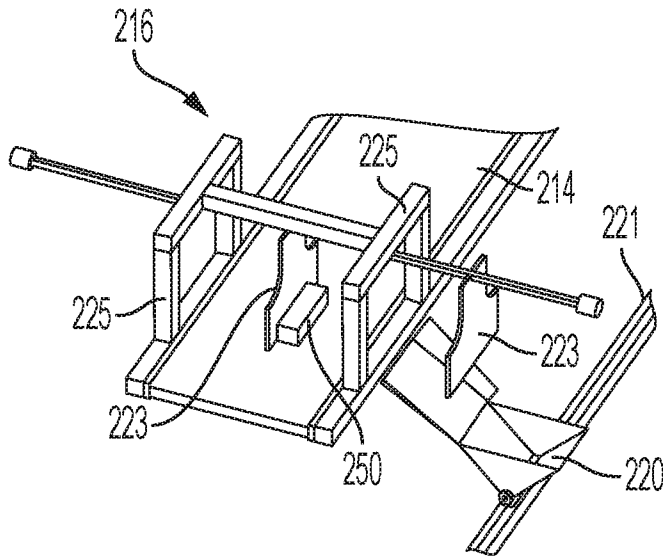

FIG. 28B

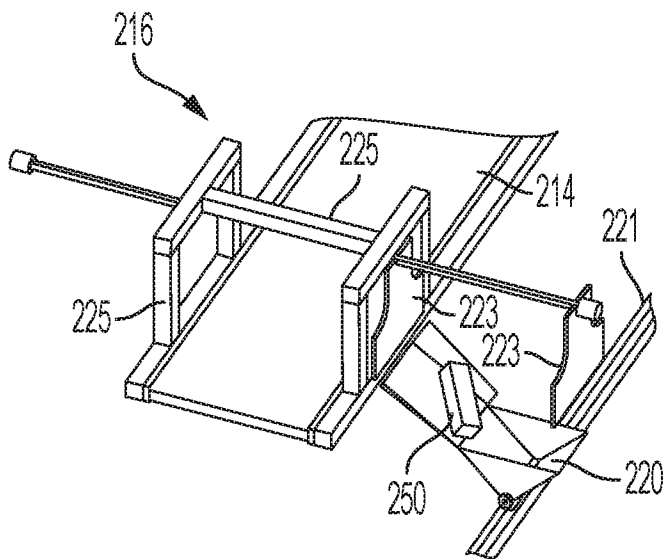

FIG. 28C

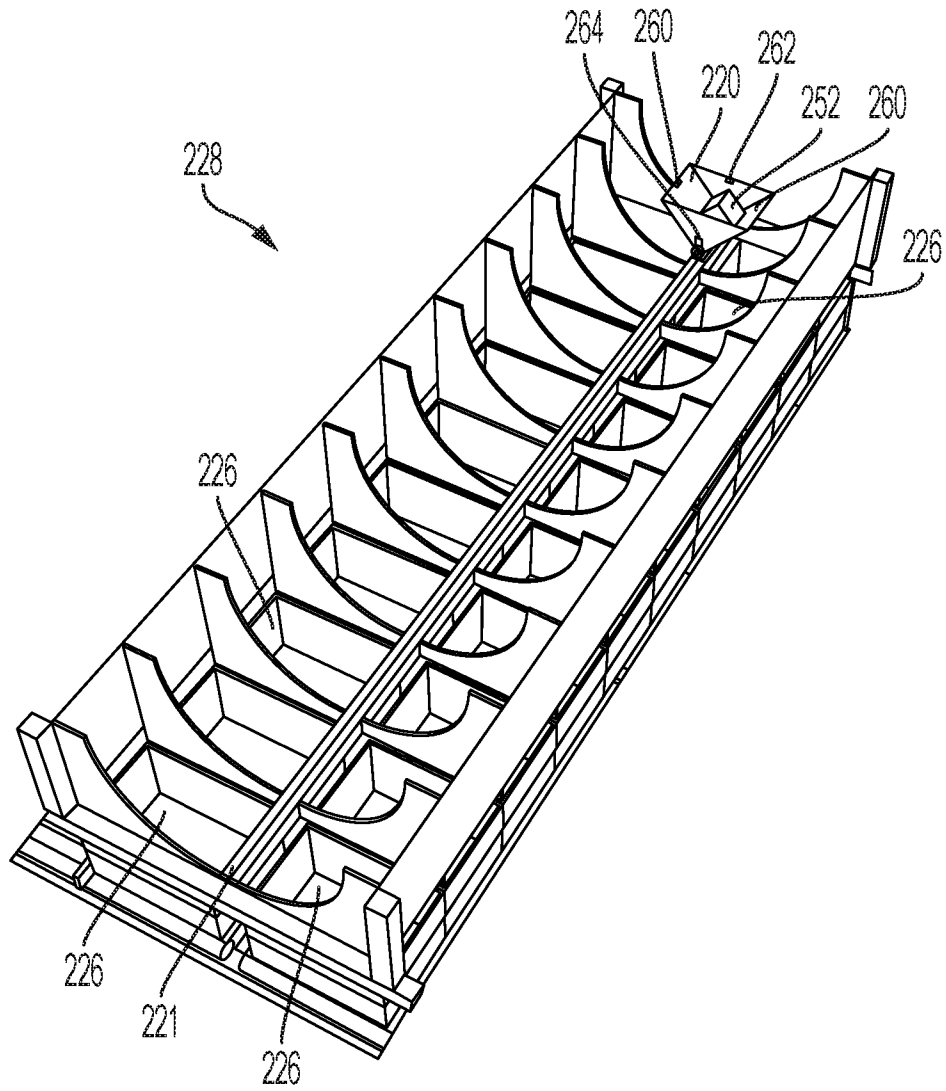

FIG. 29

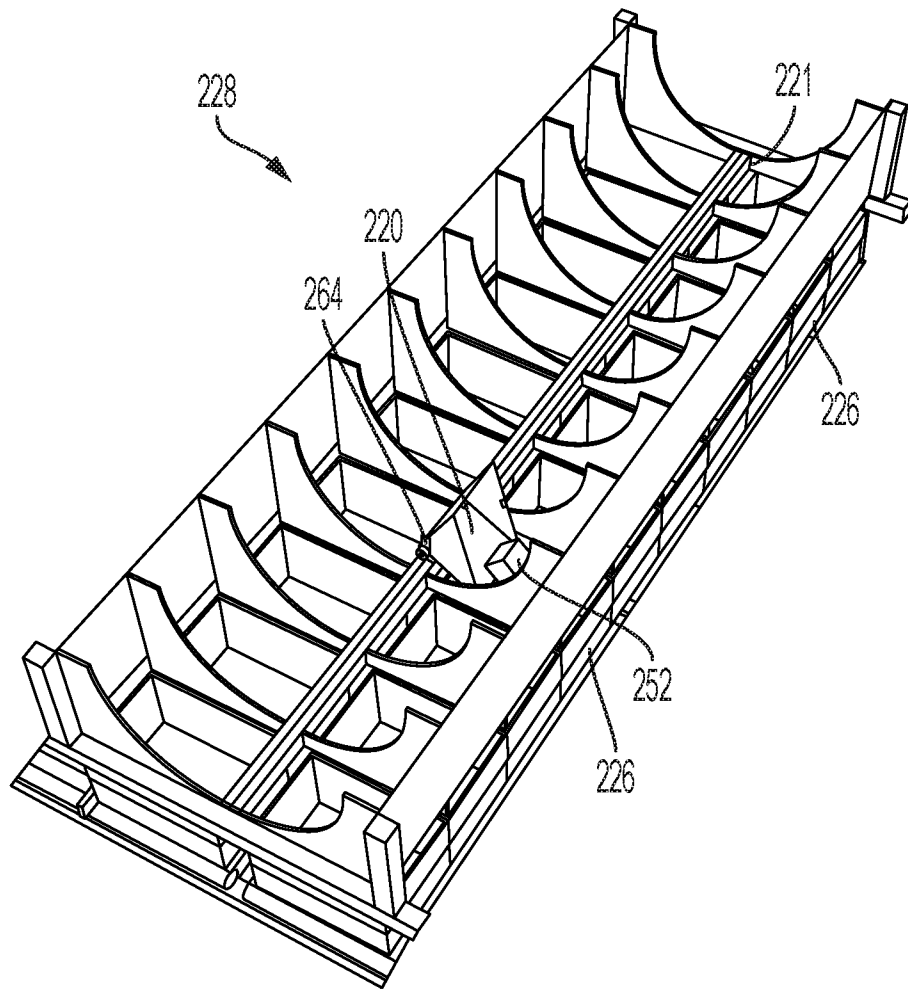

FIG. 30

27/69

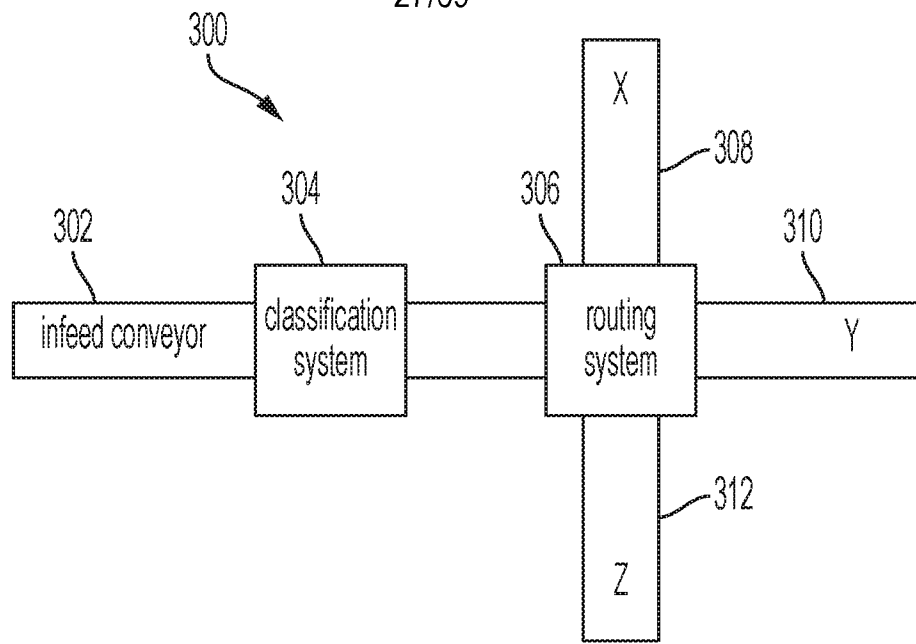

FIG. 31

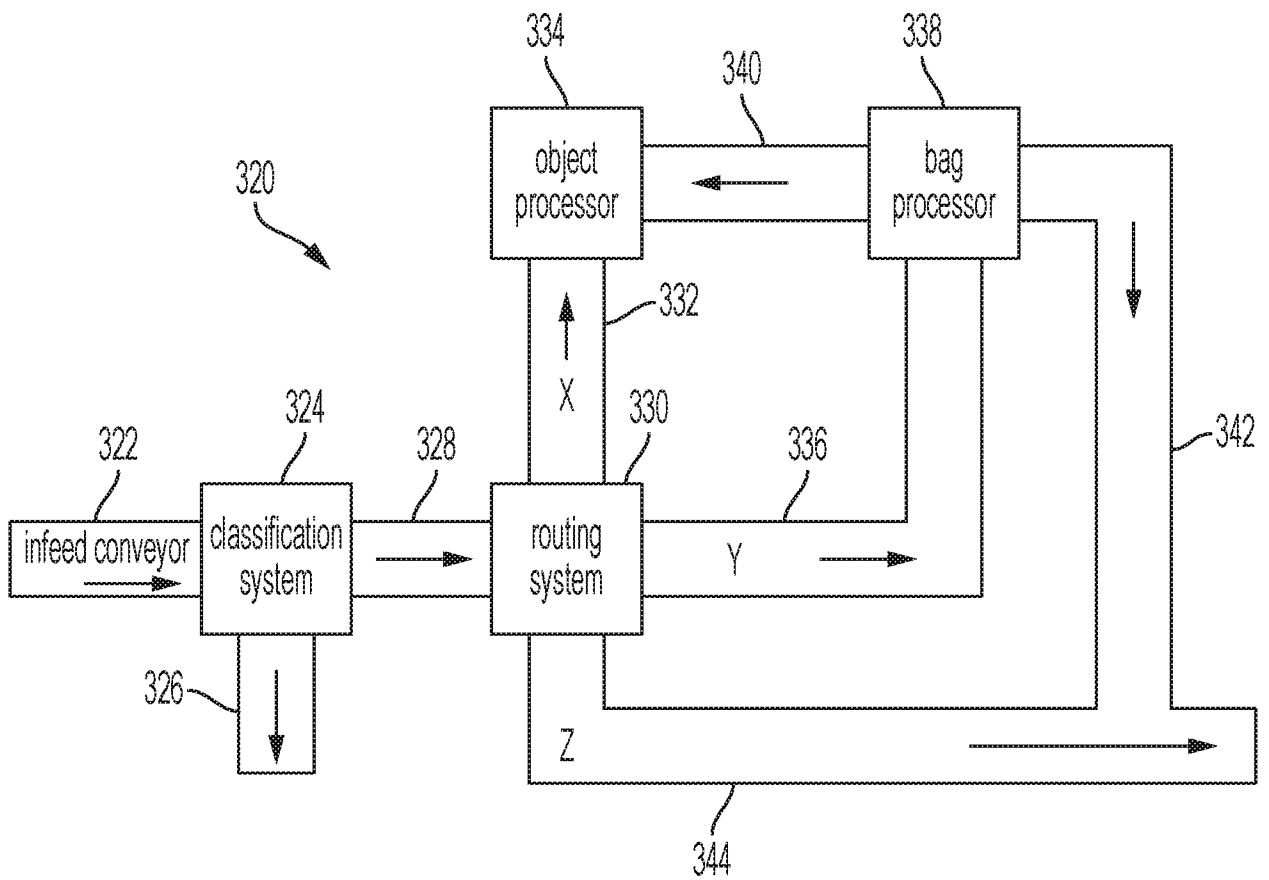

FIG. 32

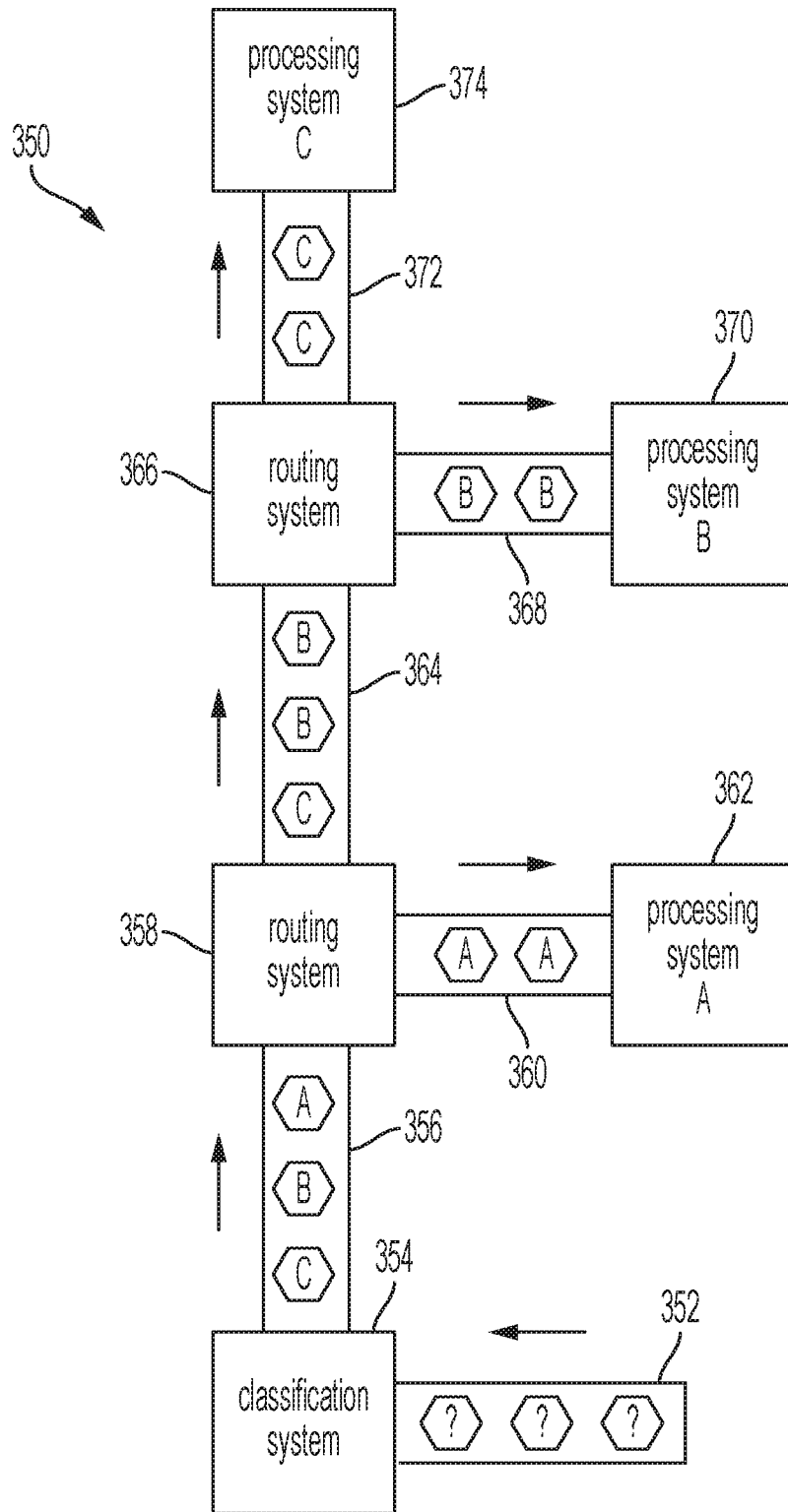

FIG. 33

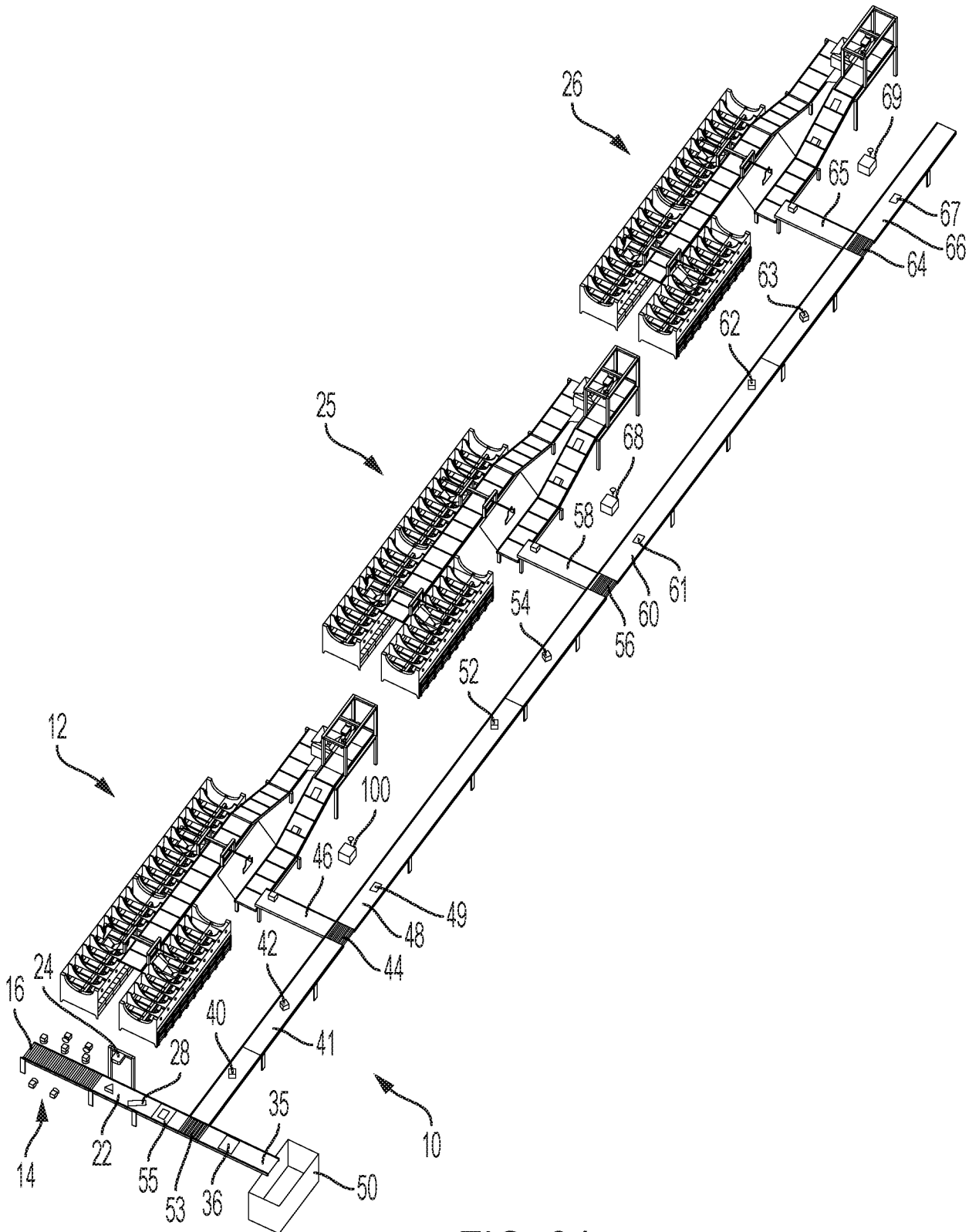

FIG. 34

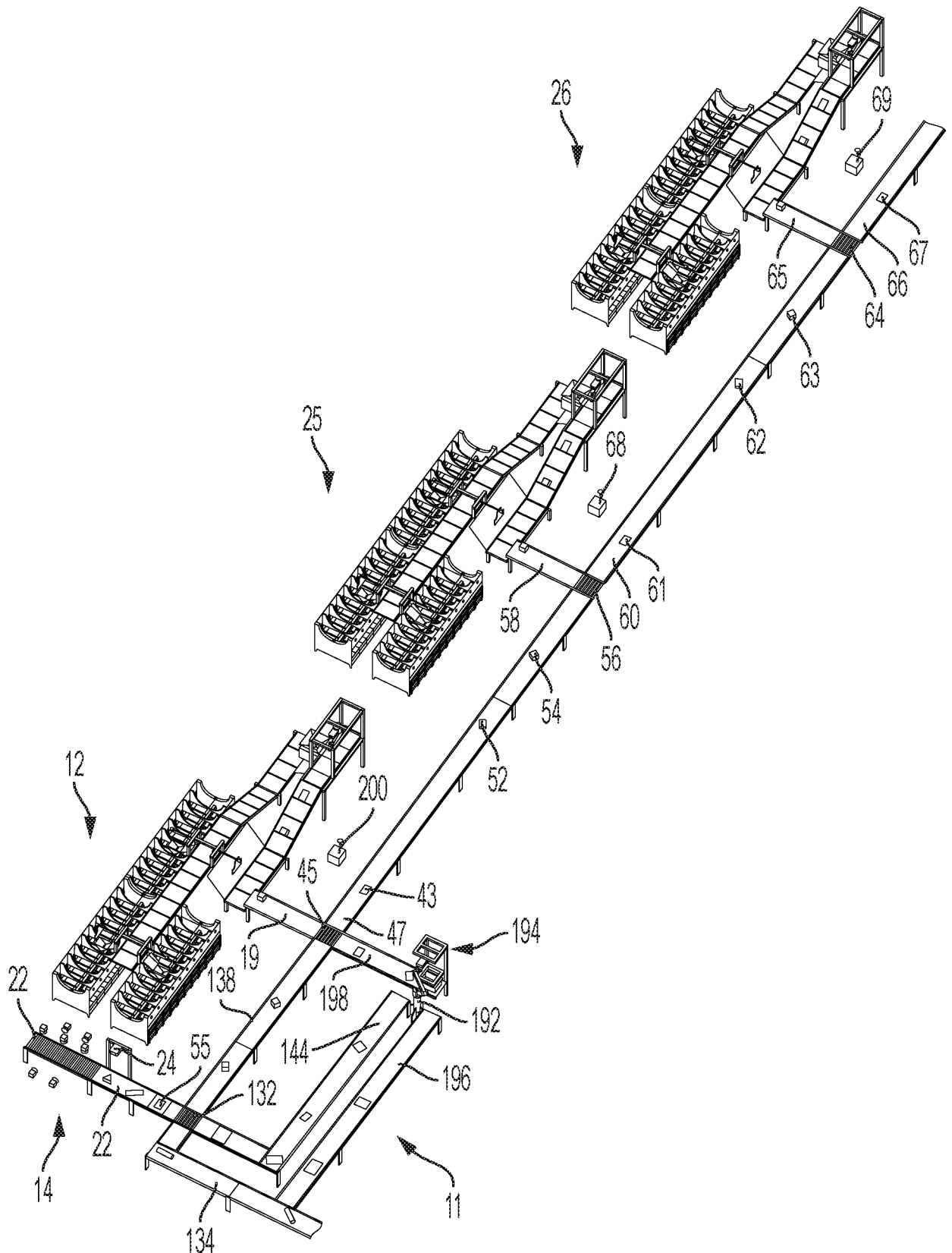

FIG. 35

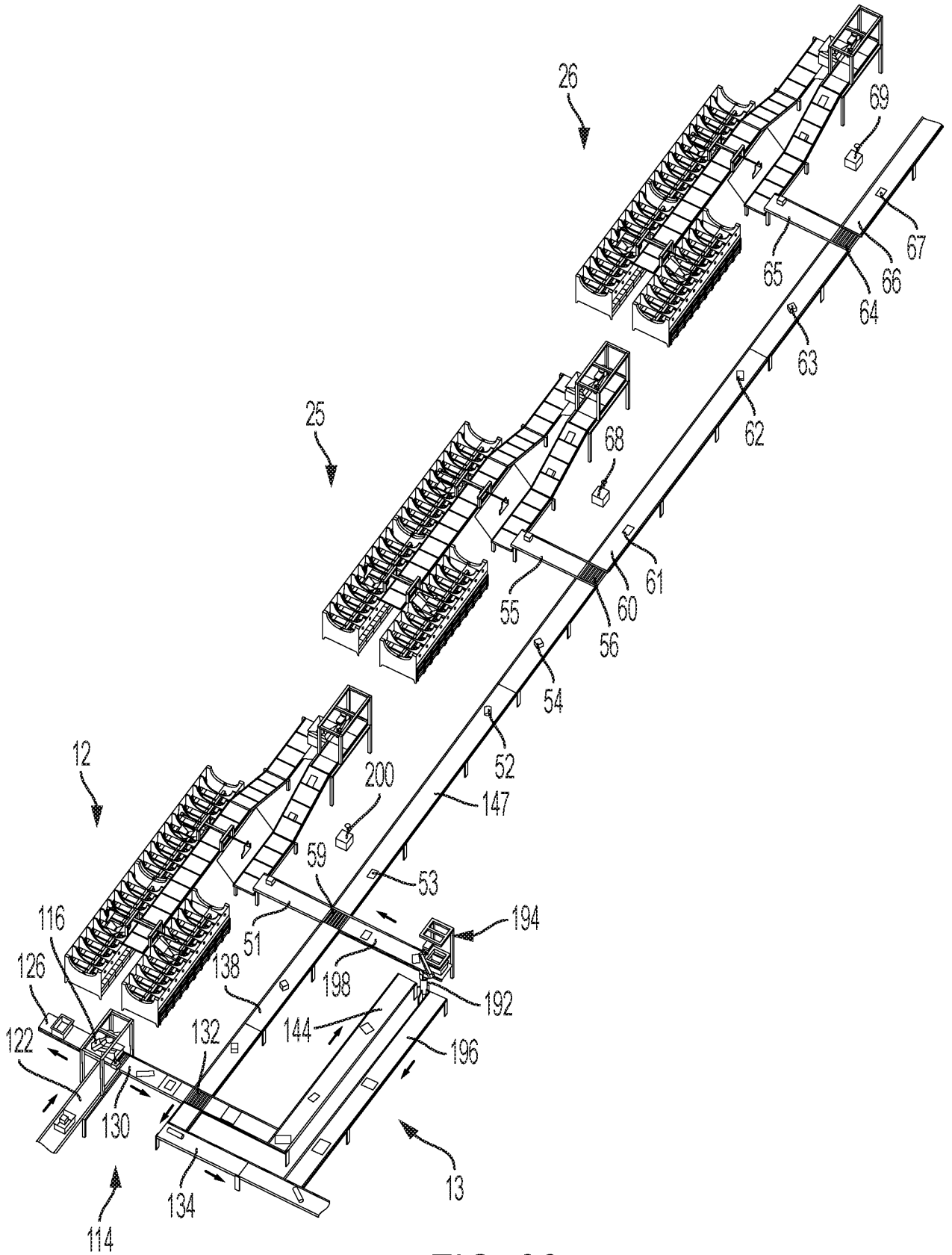

FIG. 36

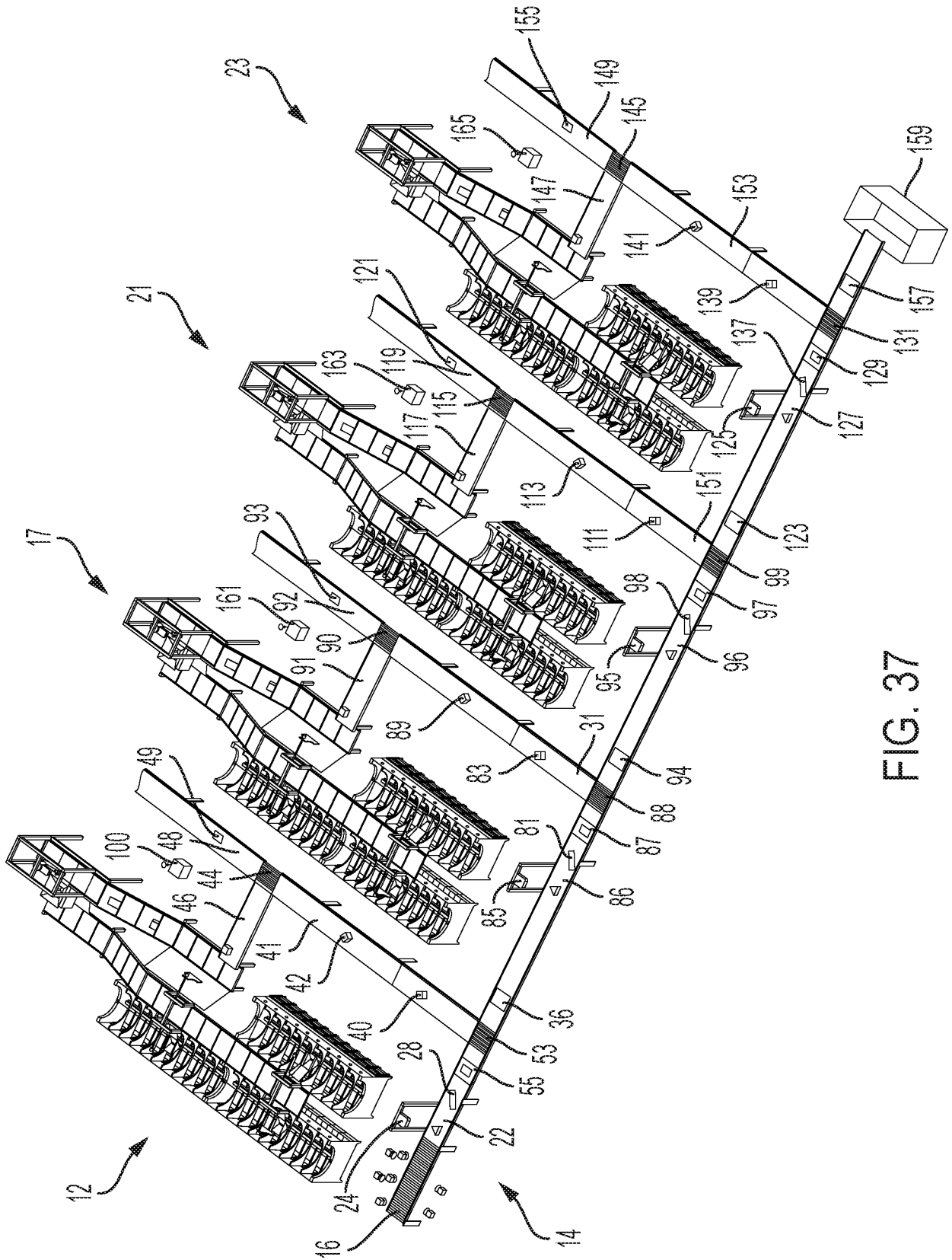

FIG. 37

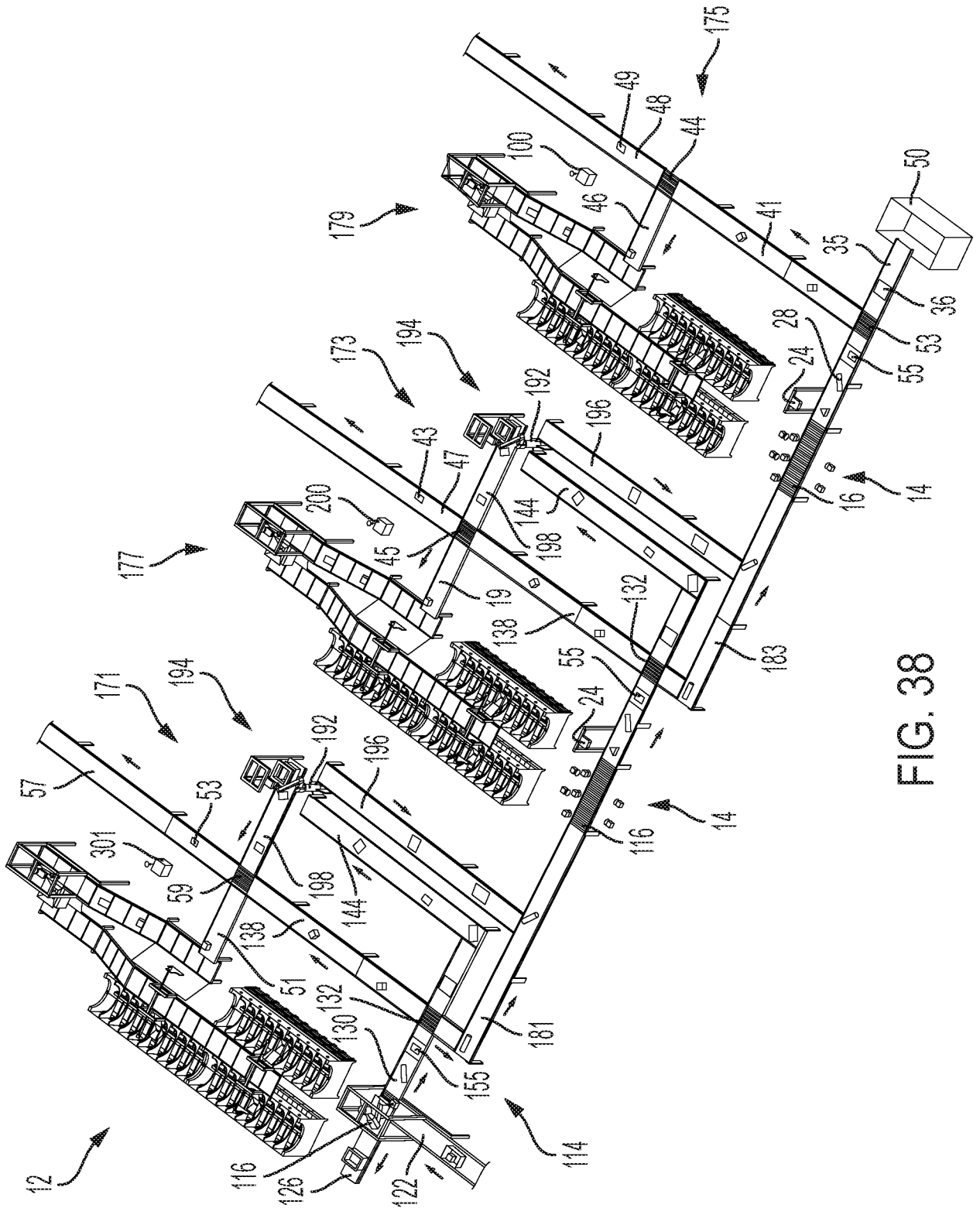

FIG. 38

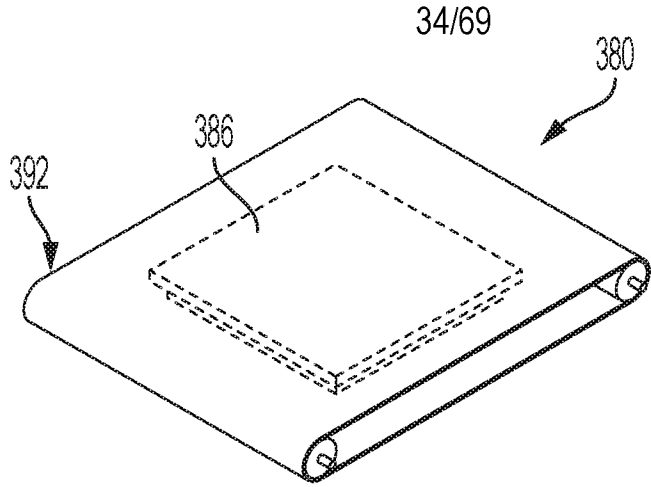

FIG. 39A

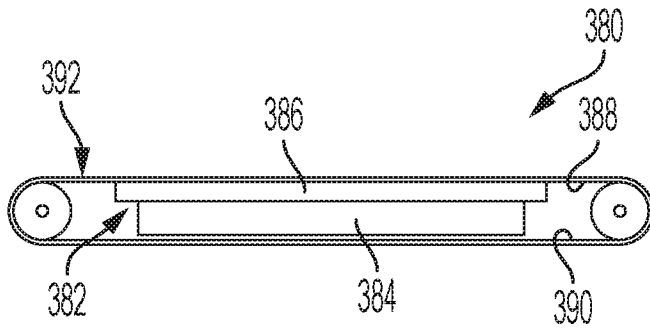

FIG. 39B

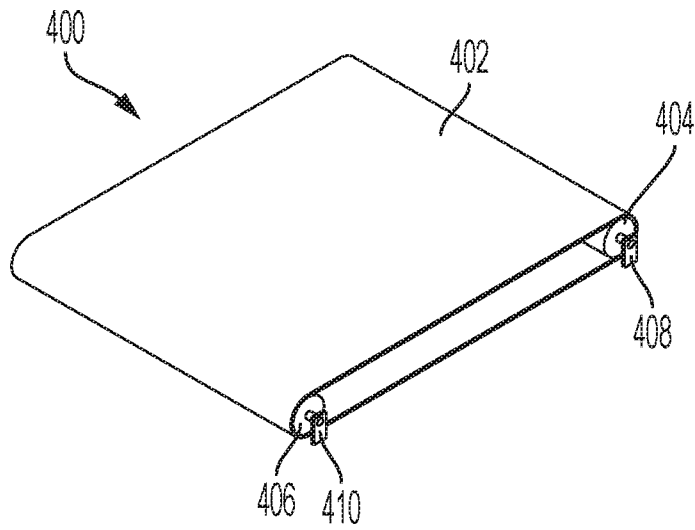

FIG. 40A

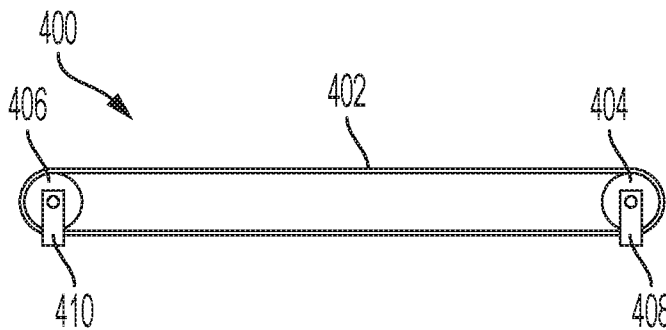
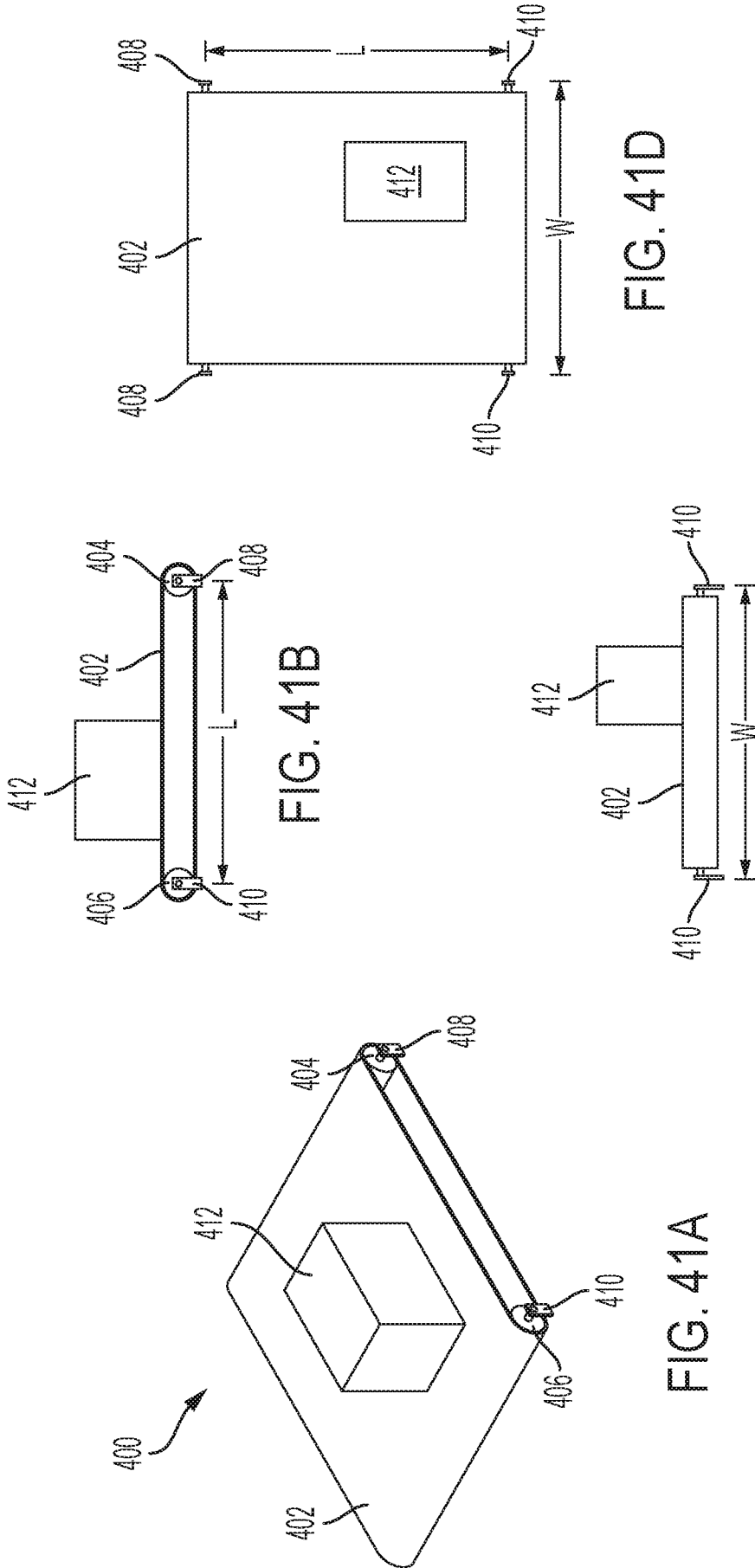

FIG. 40B



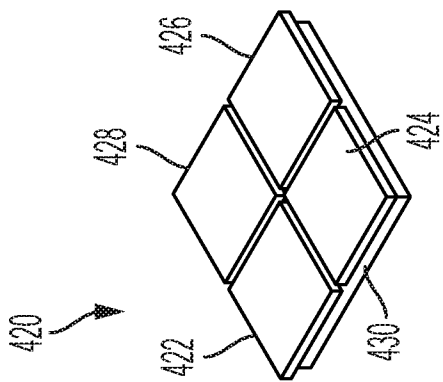

FIG. 42A

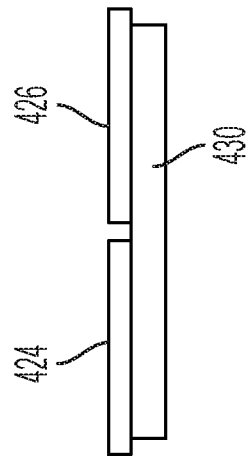

FIG. 42B

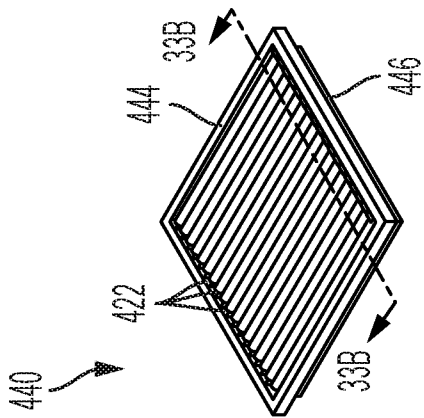

FIG. 43A

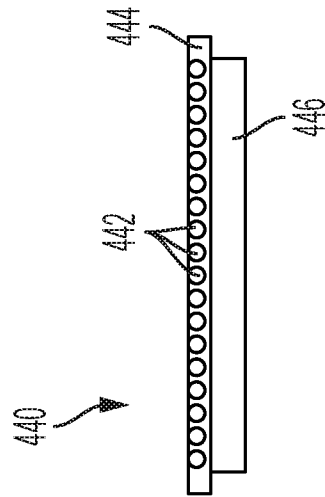

FIG. 43B

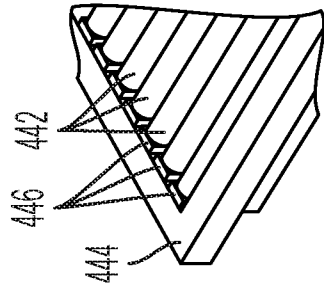

FIG. 43C

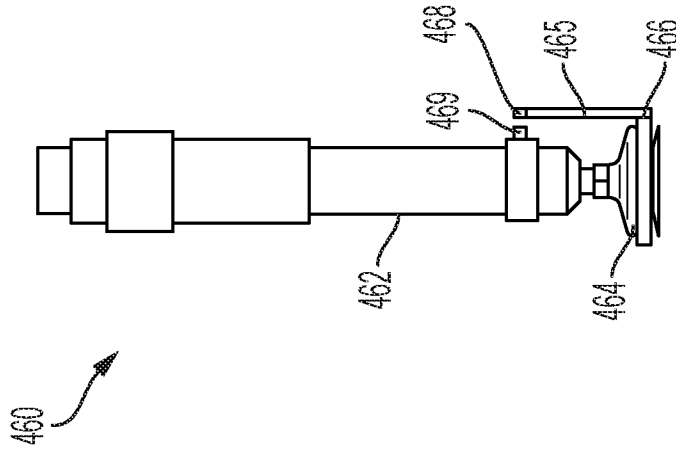

FIG. 45

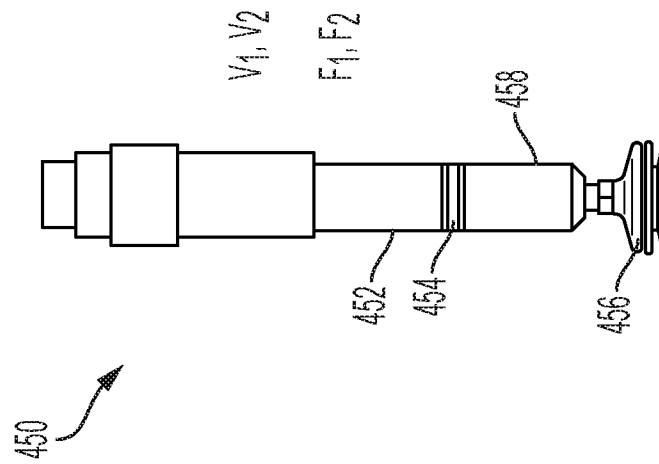

FIG. 44

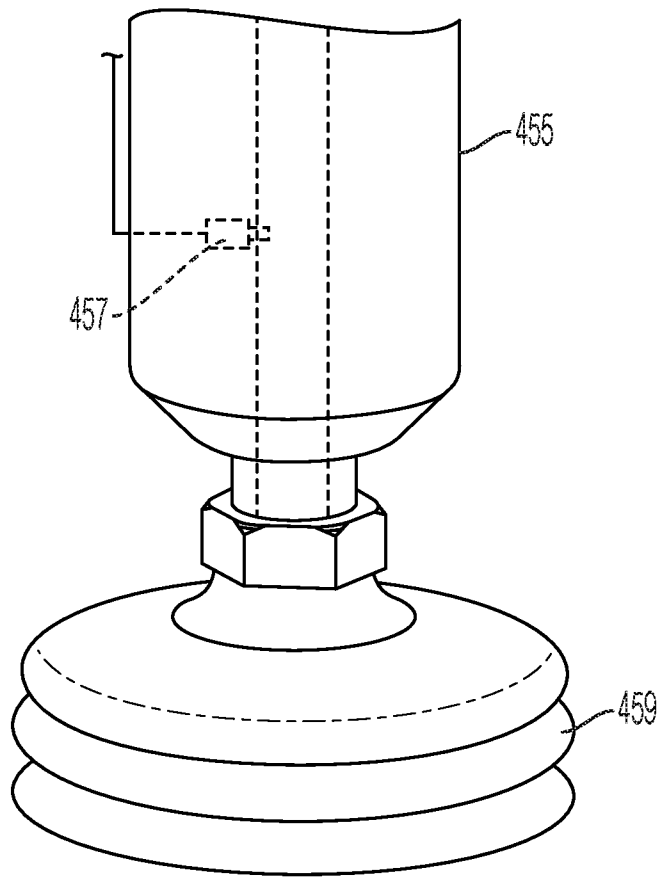

FIG. 46

39/69

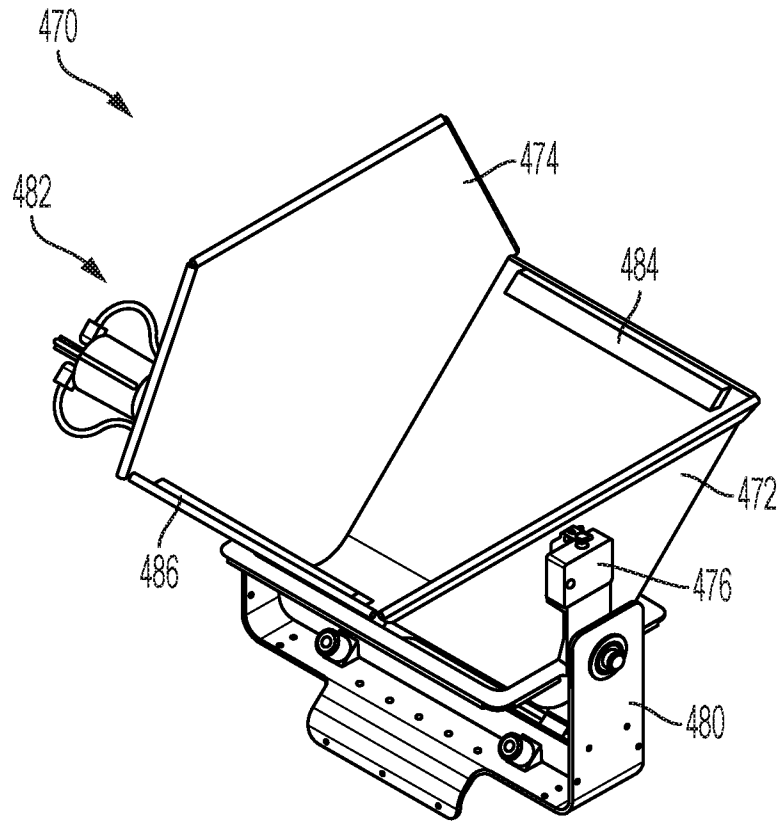

FIG. 47

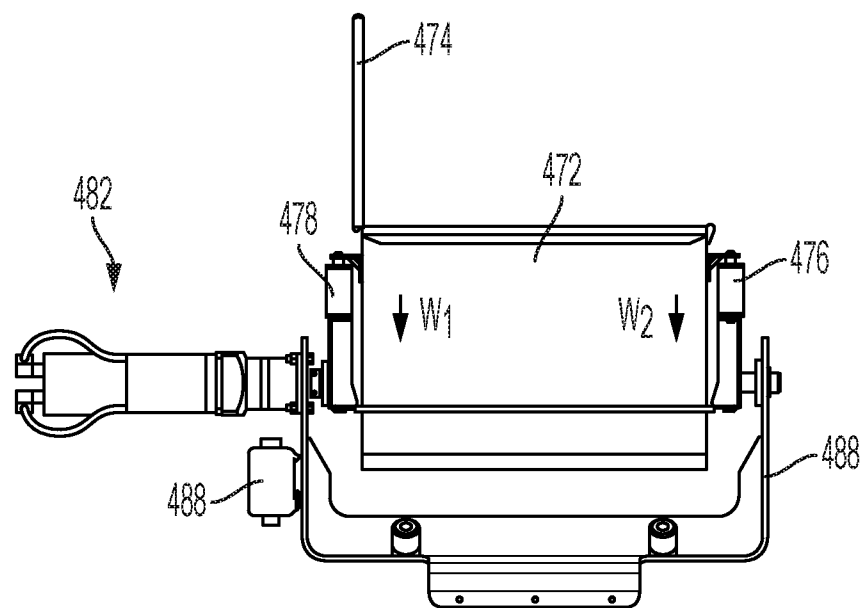

FIG. 48

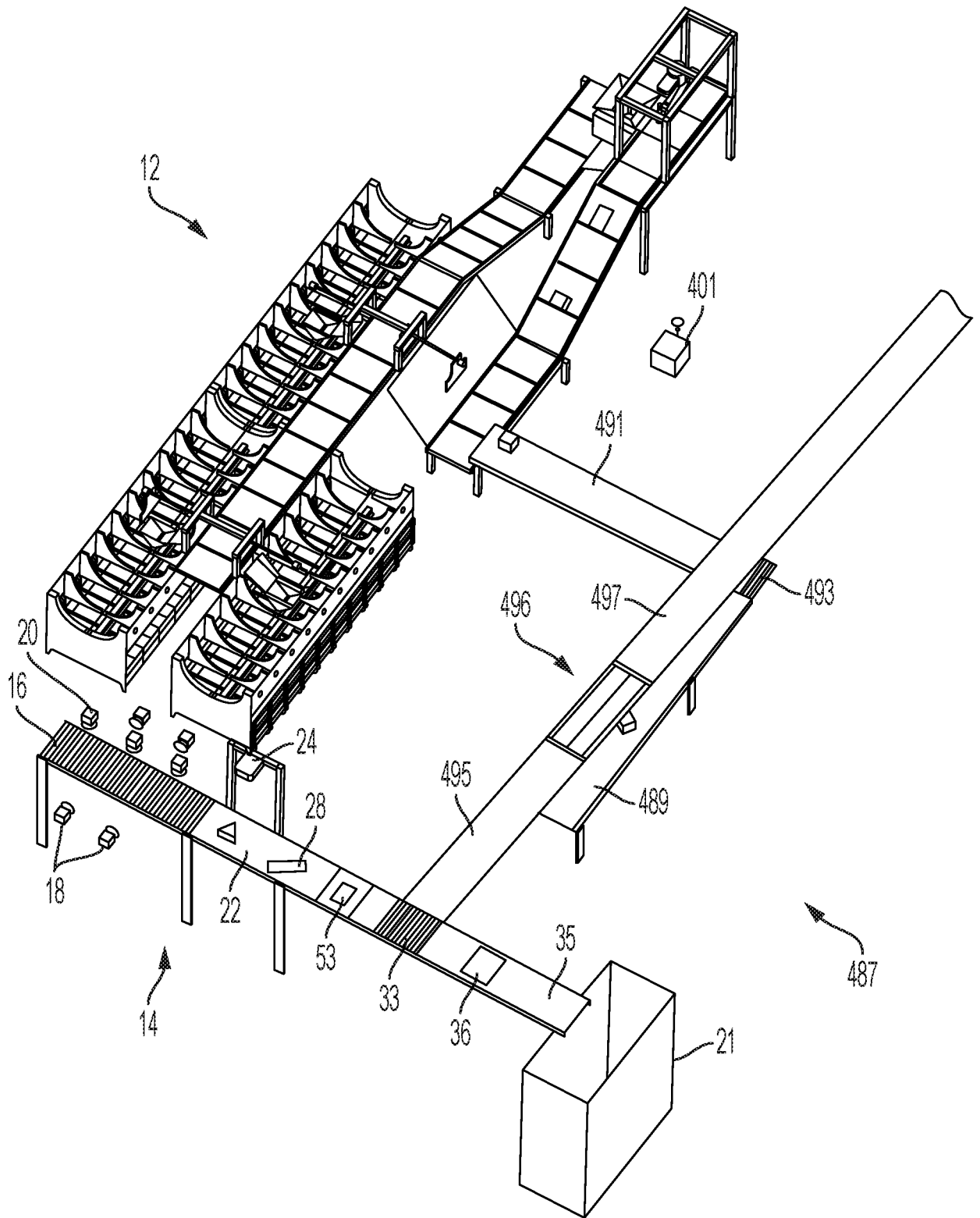

FIG. 49

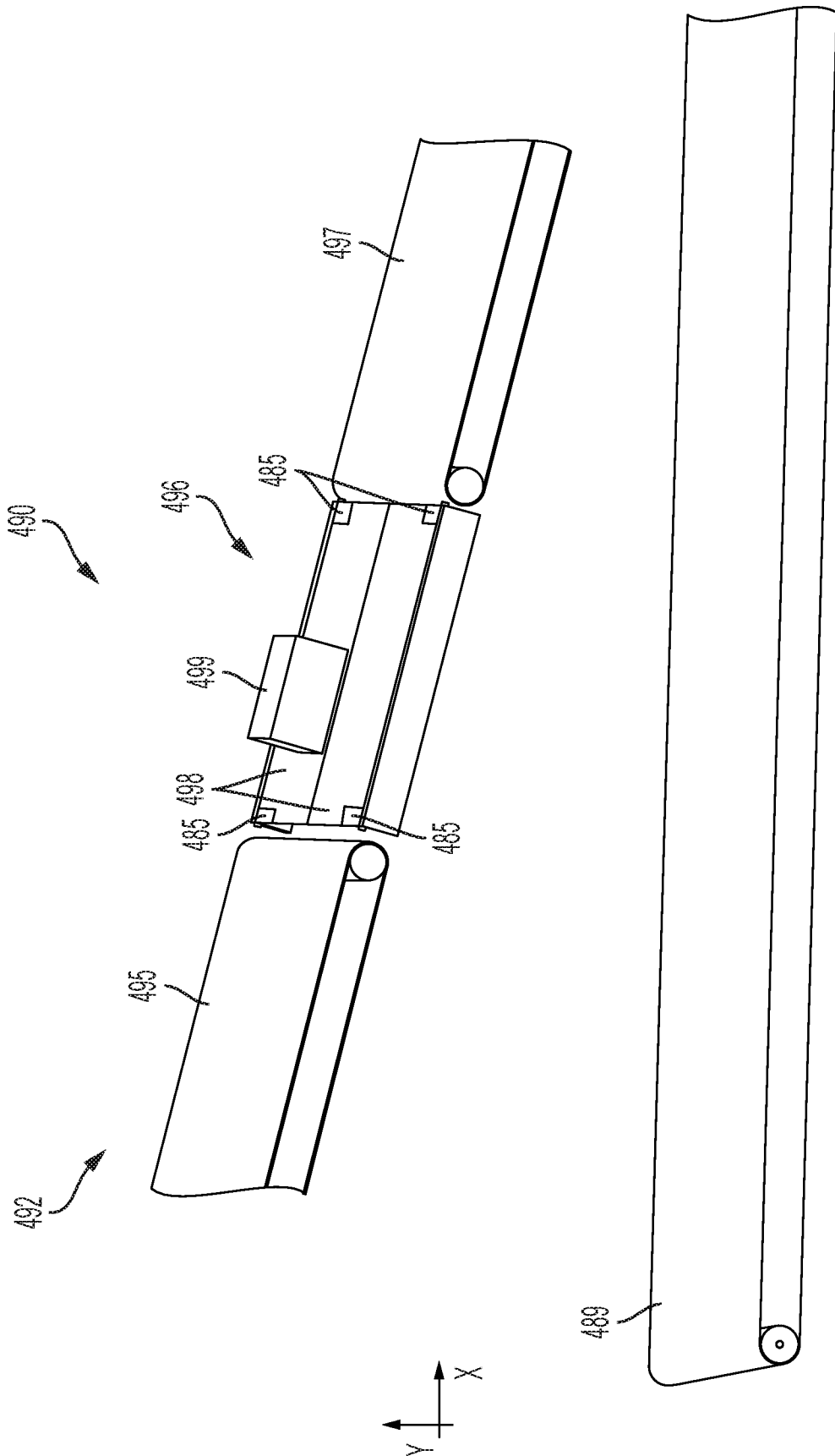

FIG. 50A

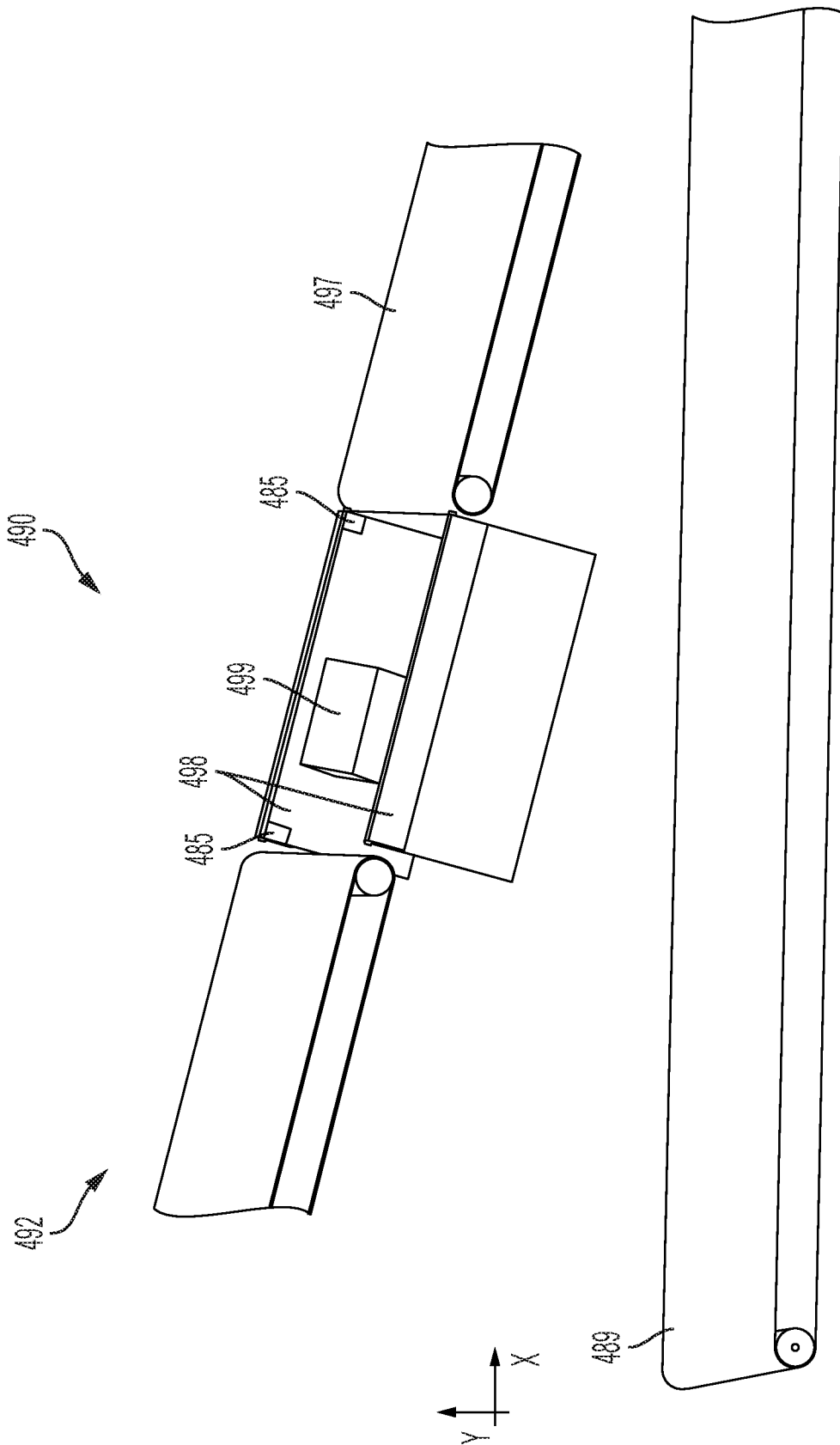

FIG. 50B

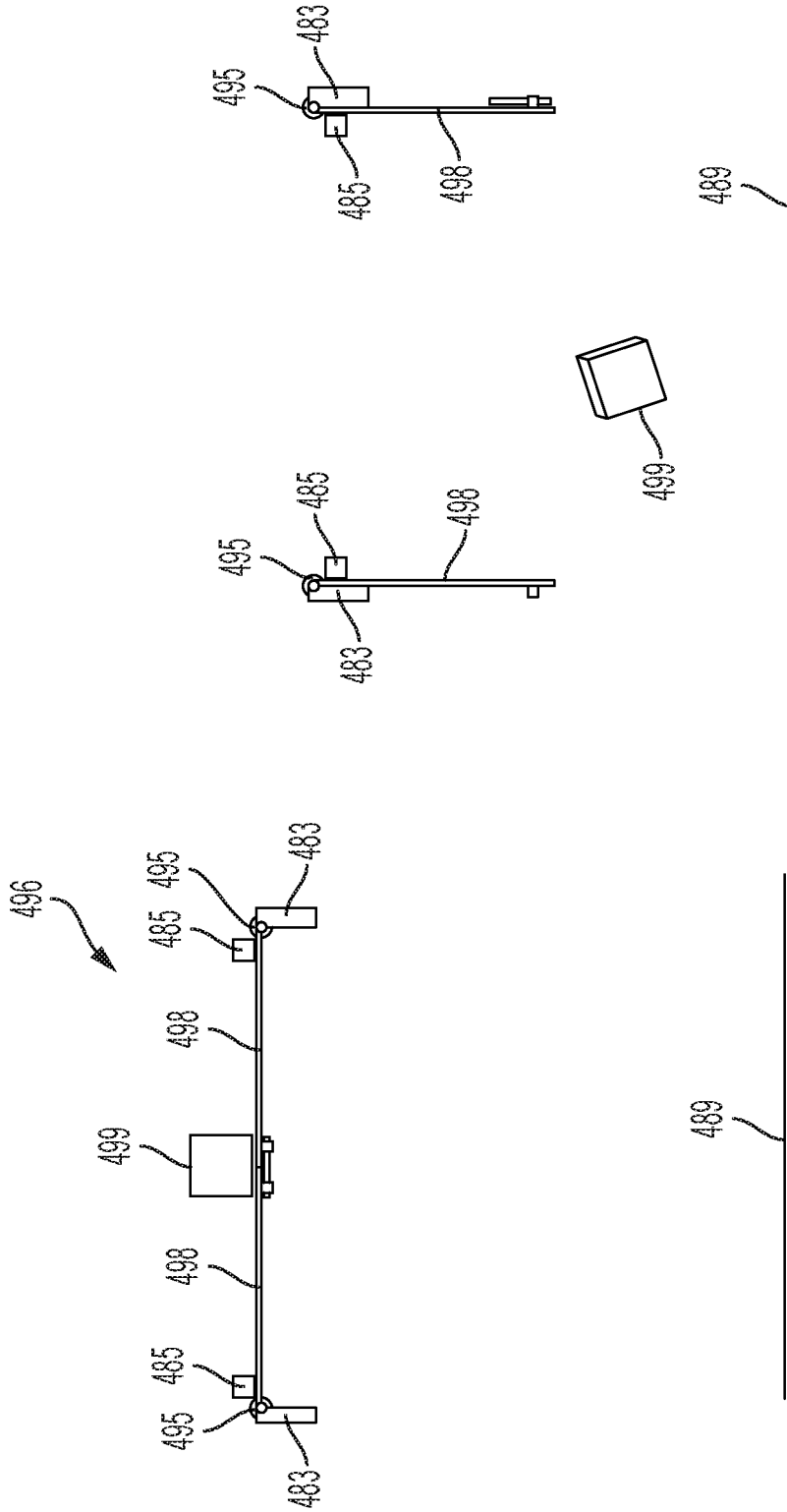

FIG. 51B

FIG. 51A

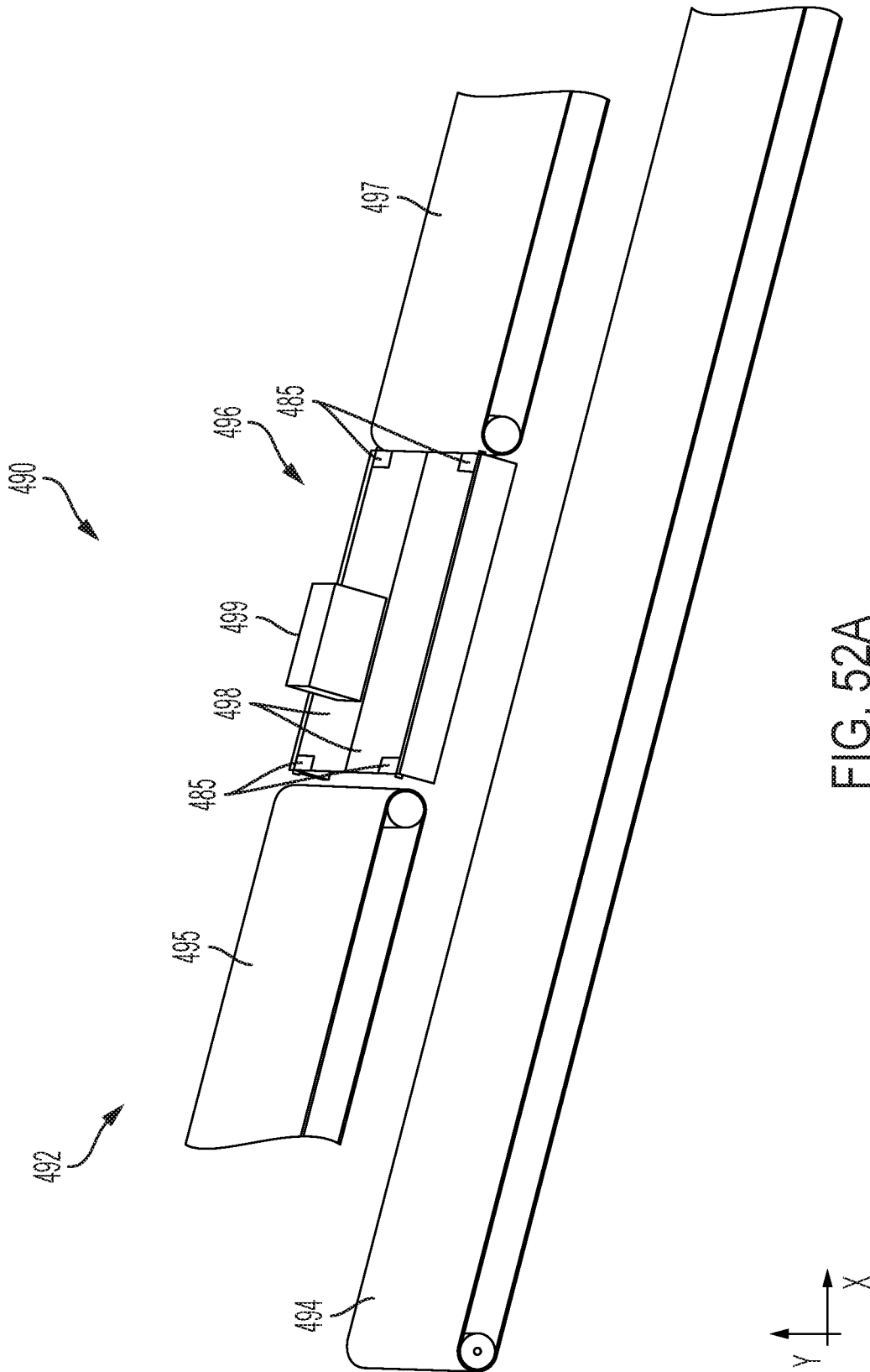

FIG. 52A

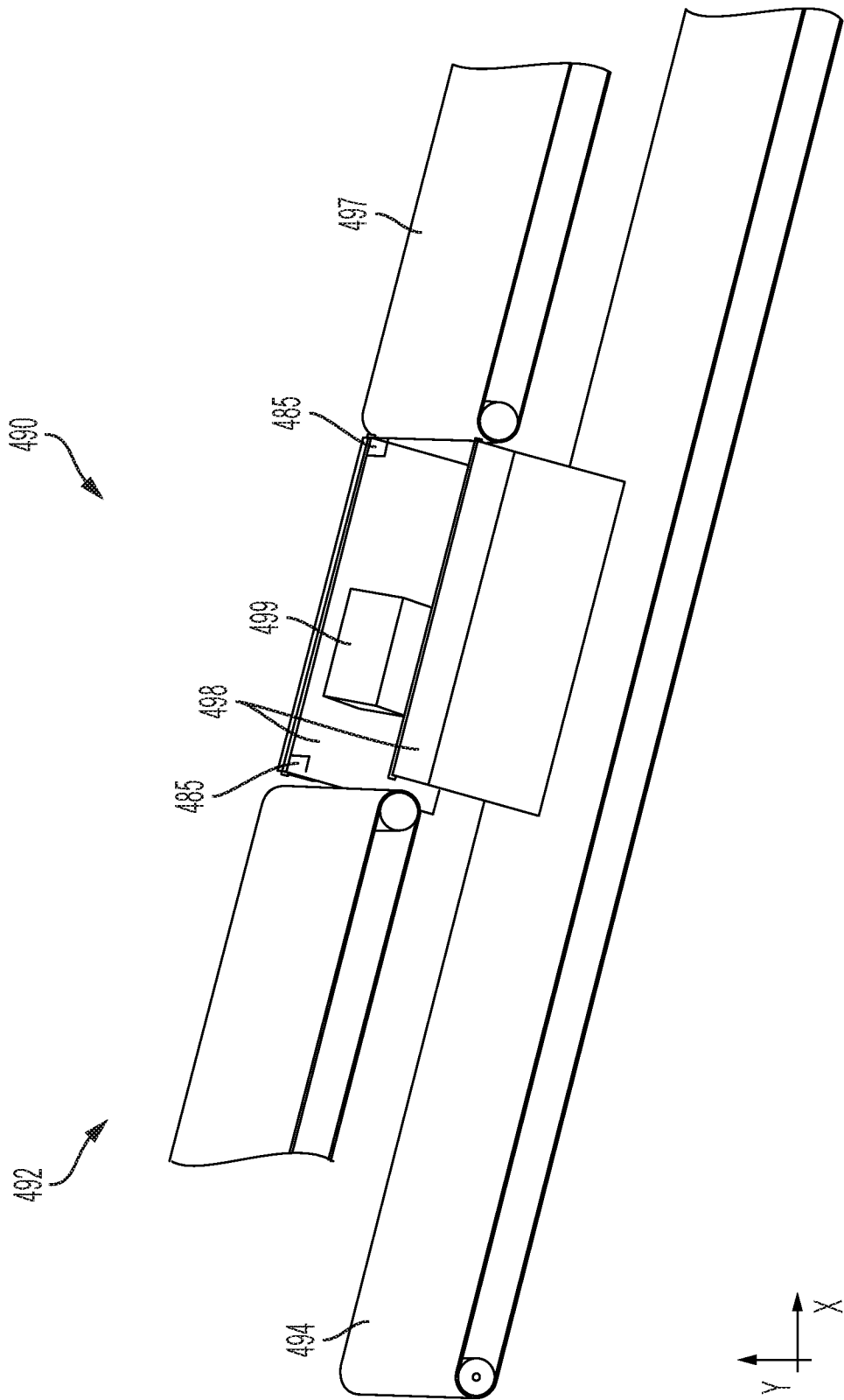

FIG. 52B

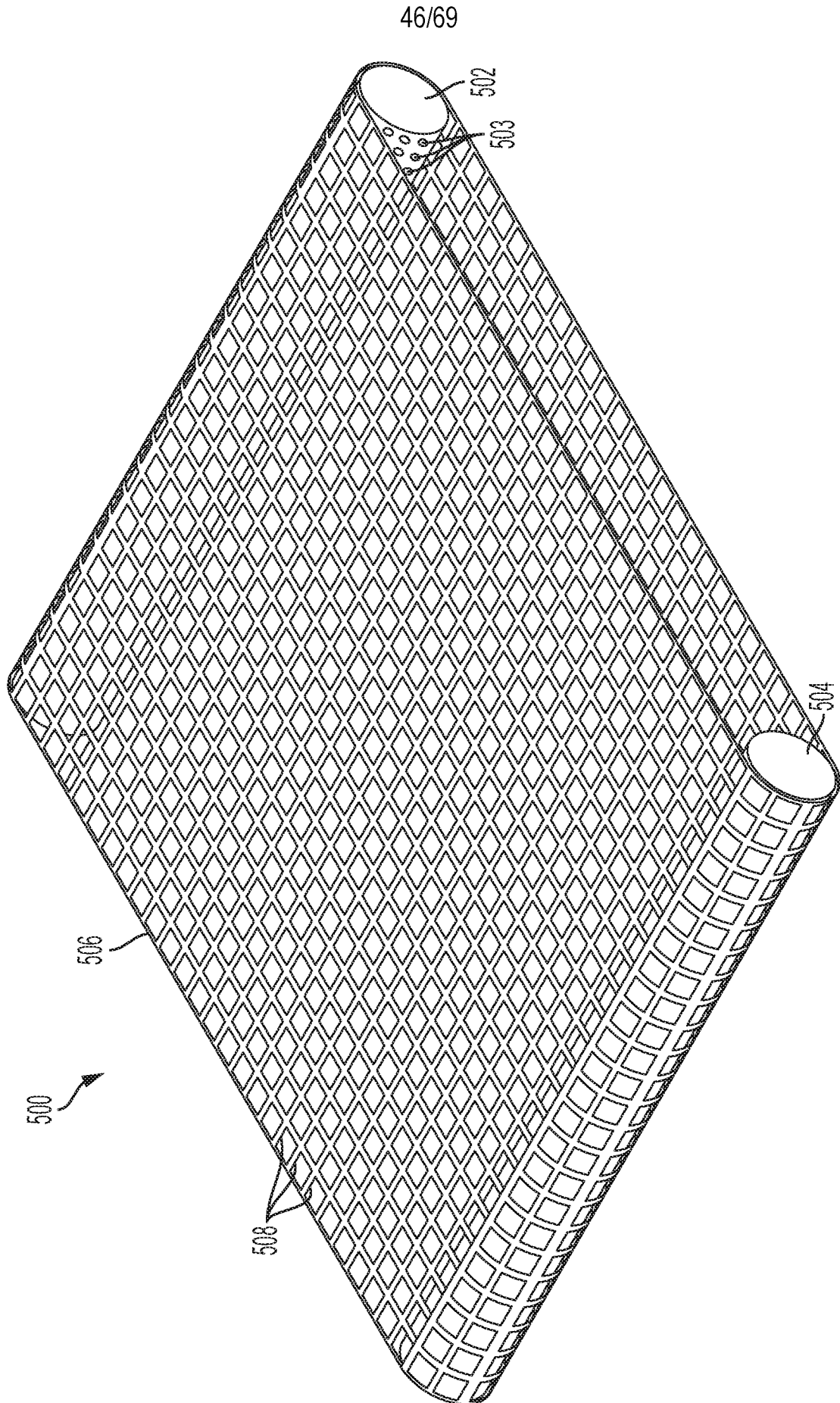

FIG. 53

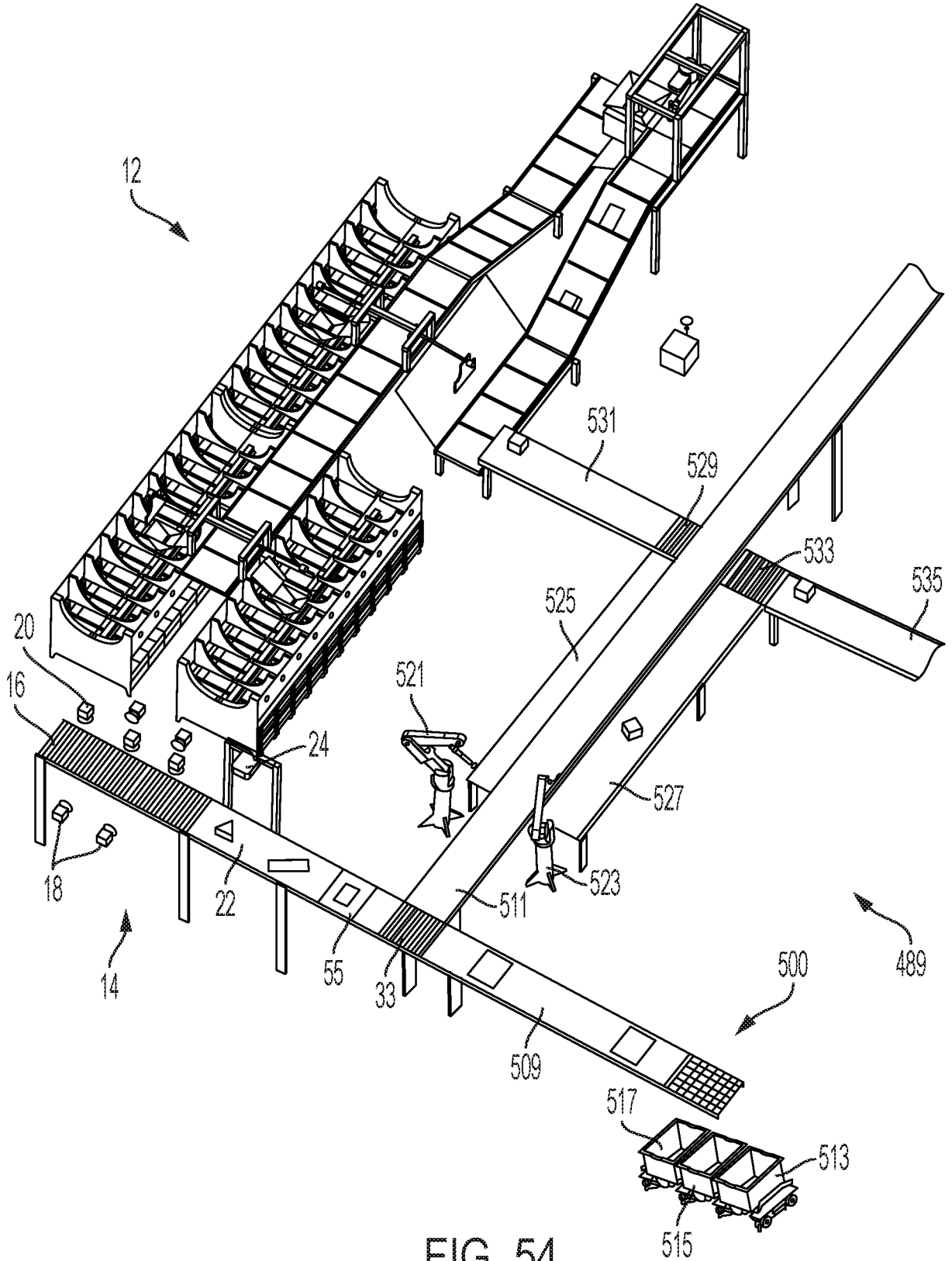

FIG. 54

48/69

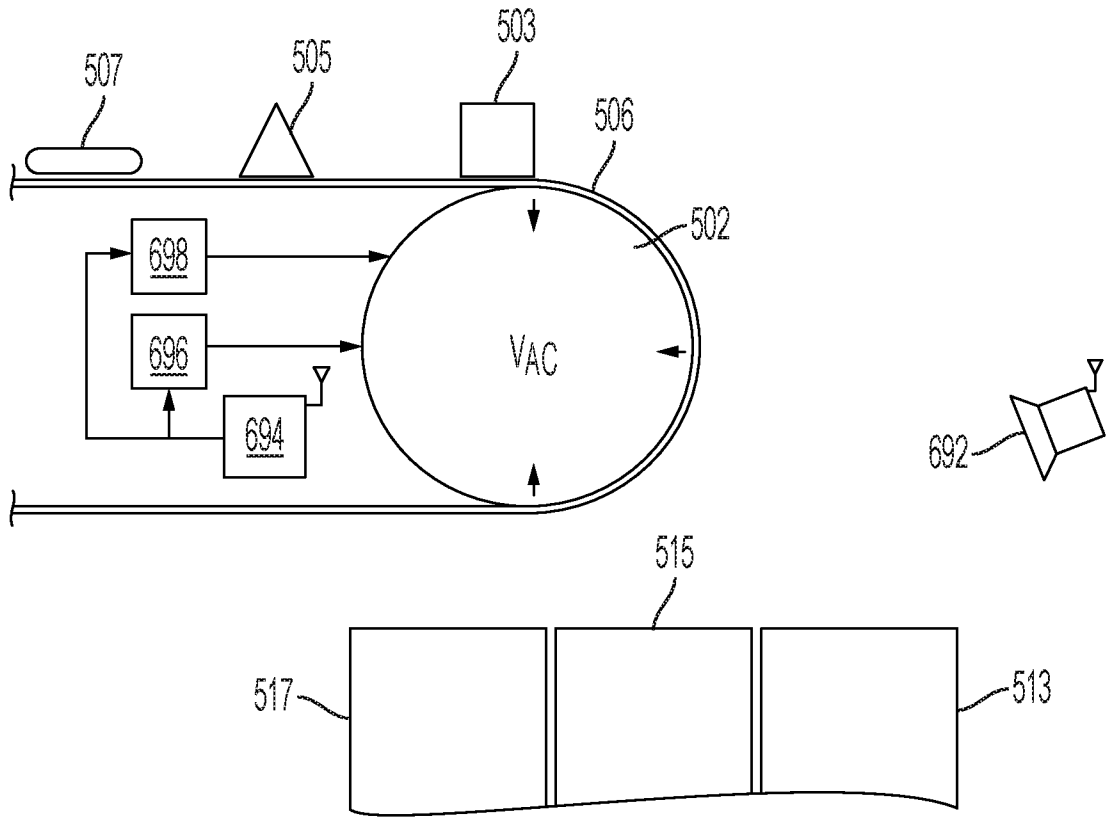

FIG. 55A

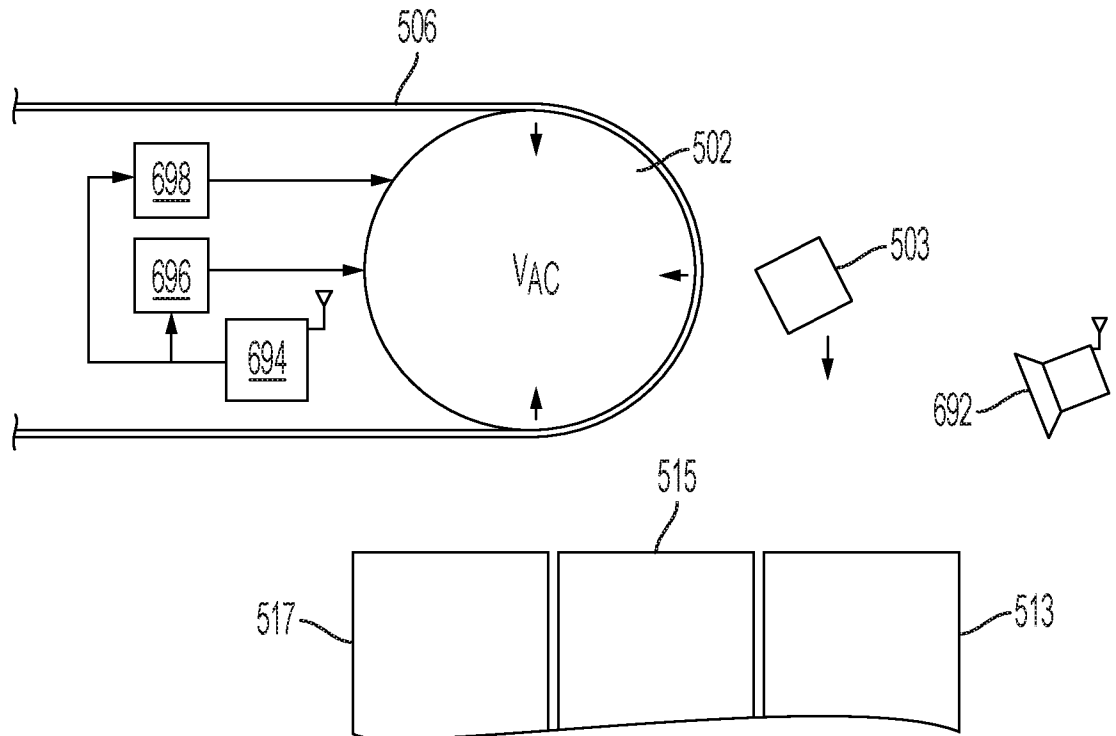

FIG. 55B

49/69

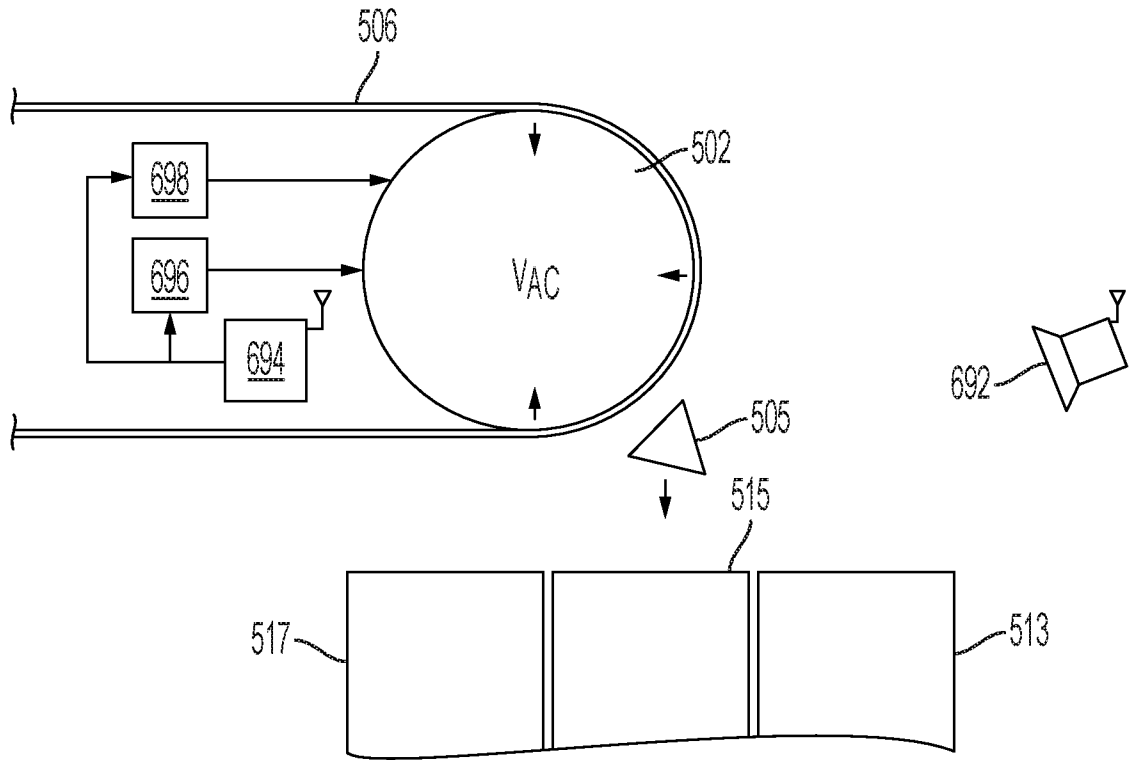

FIG. 55C

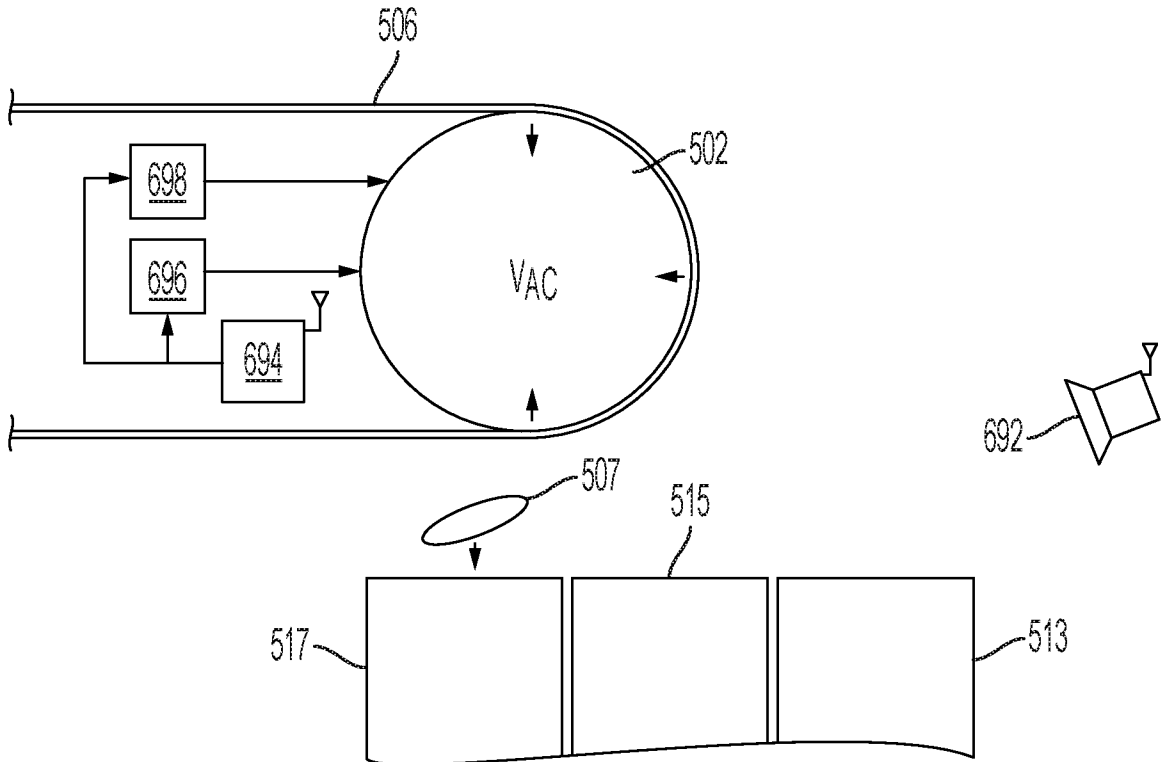

FIG. 55D

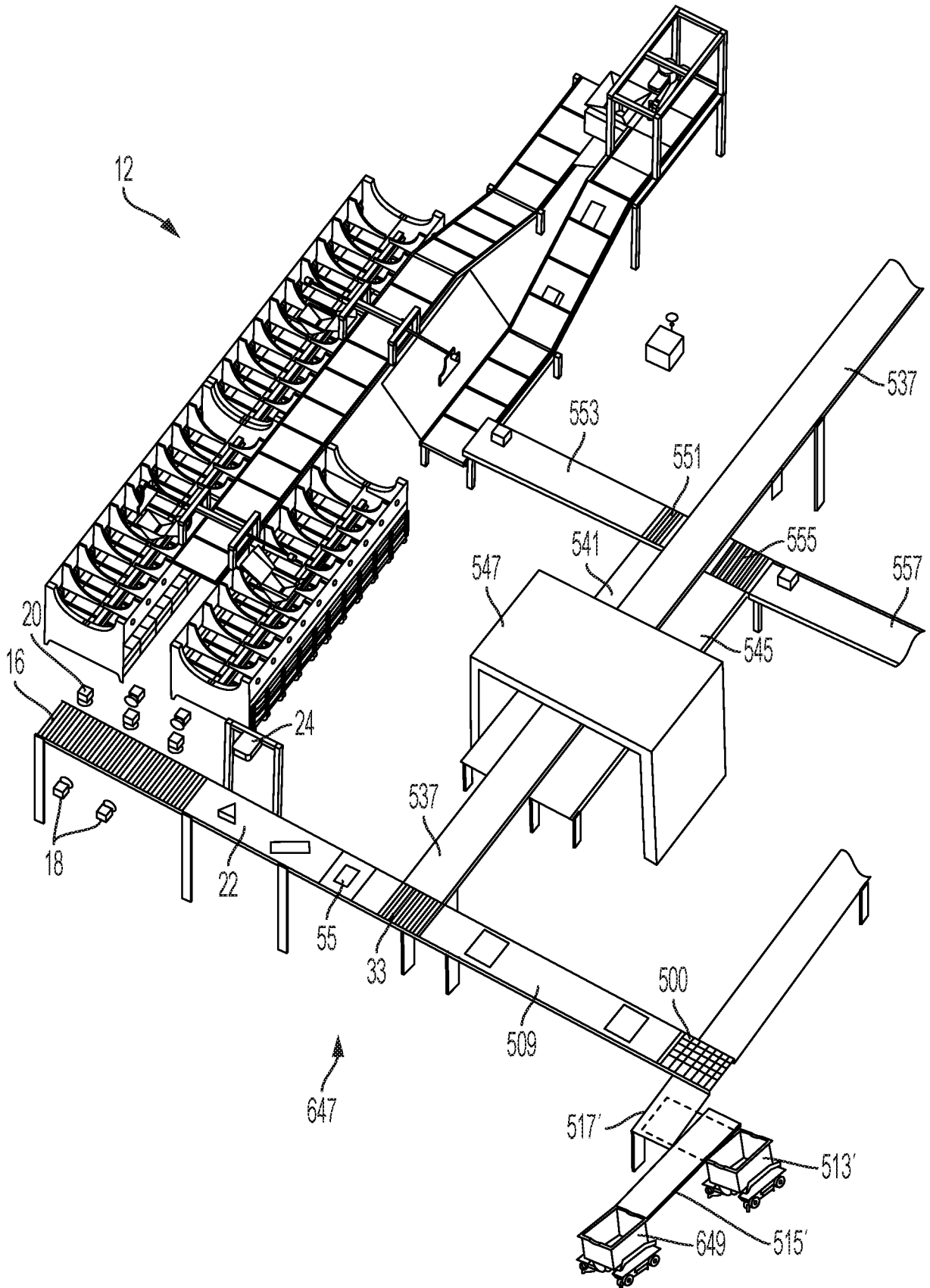

FIG. 56

51/69

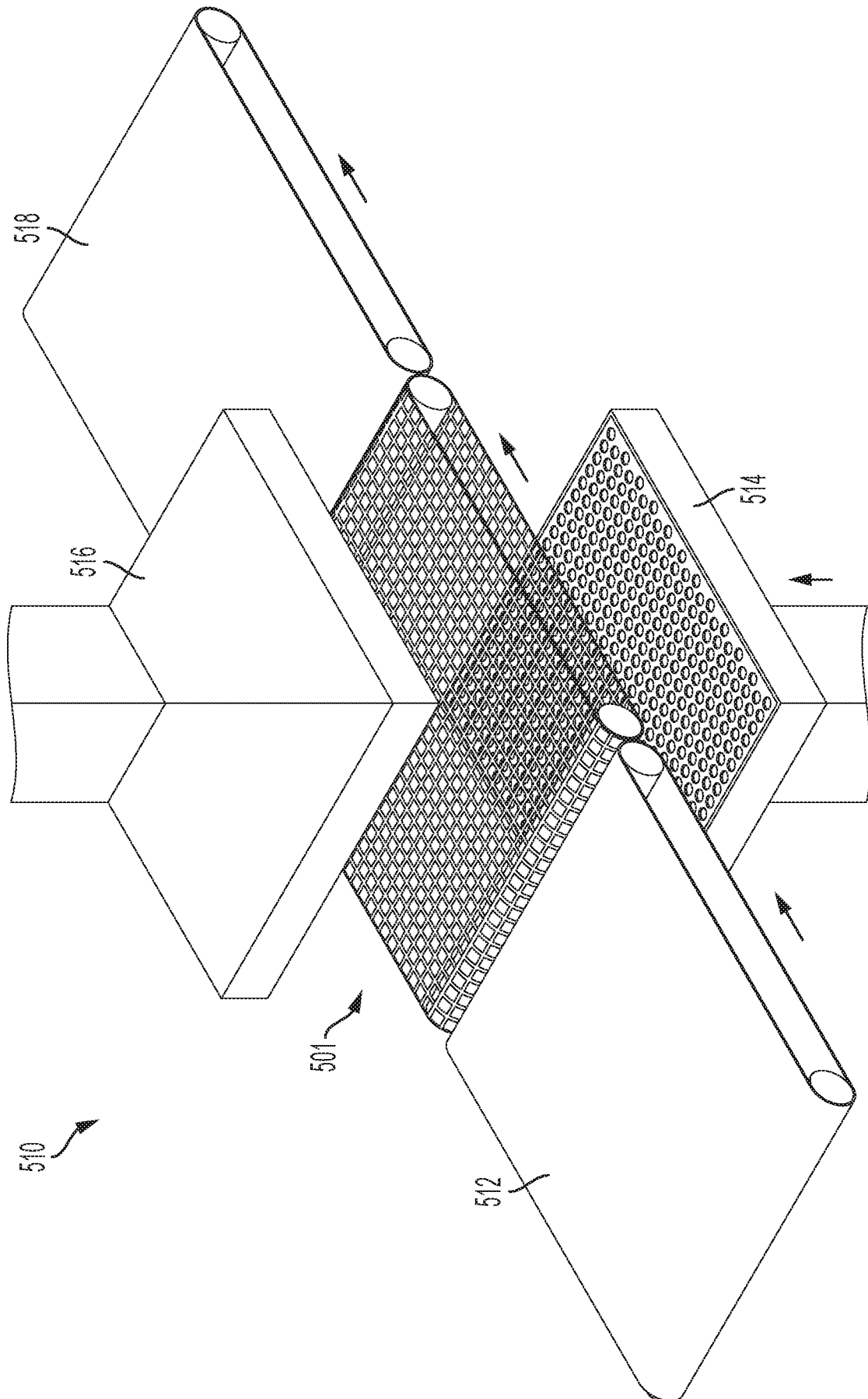

FIG. 57

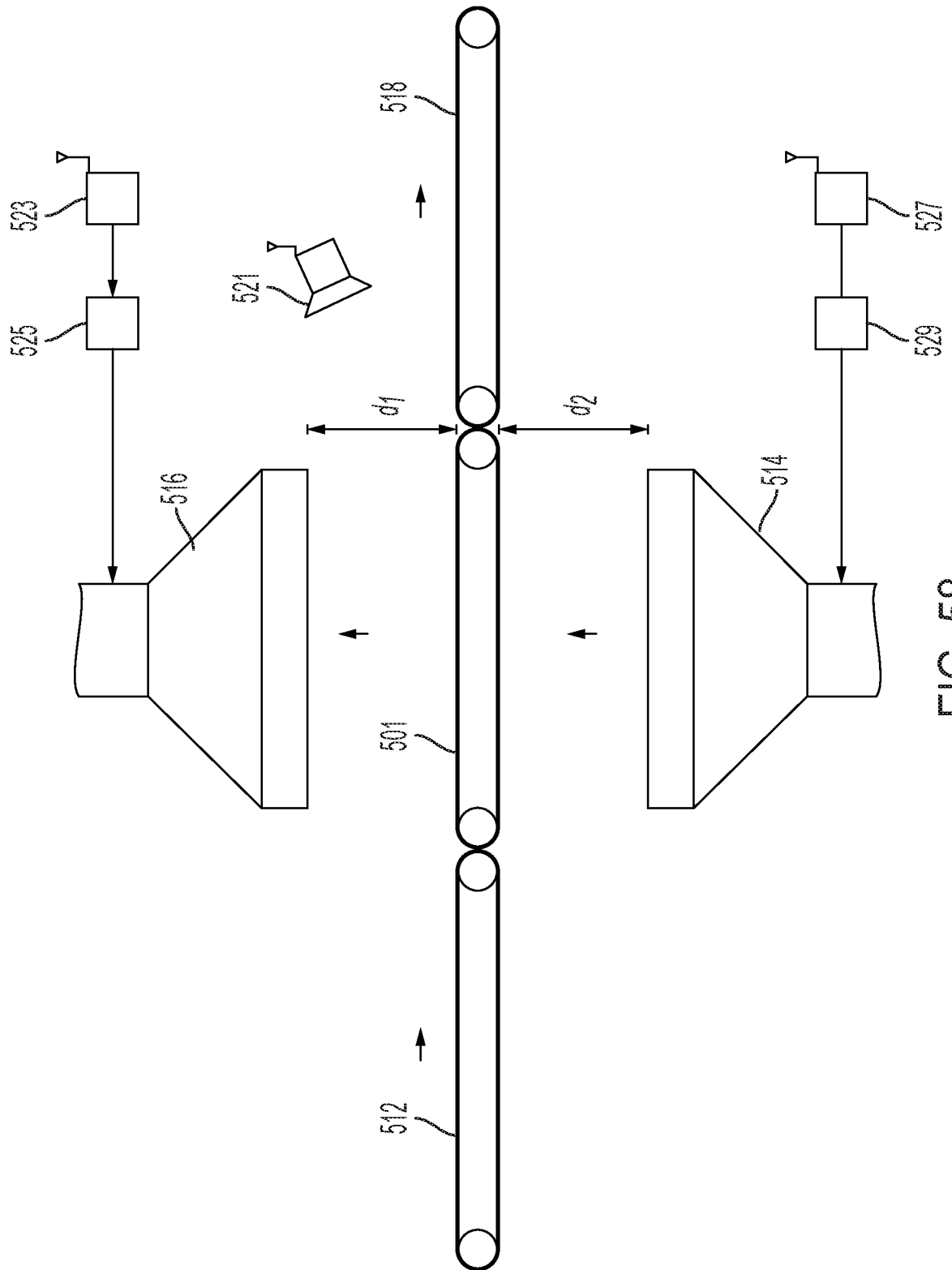

FIG. 58

53/69

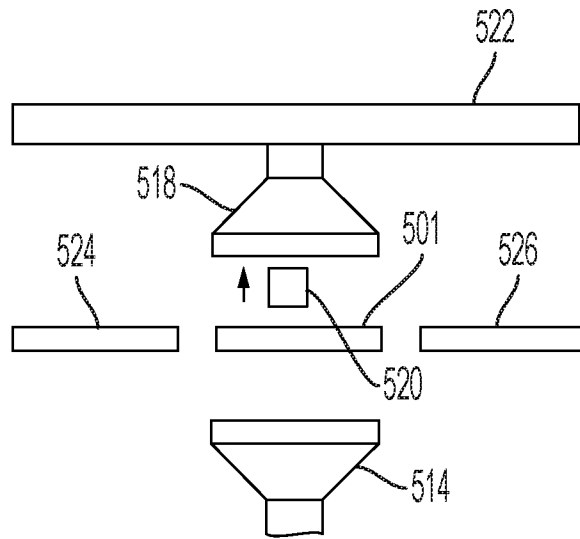

FIG. 59A

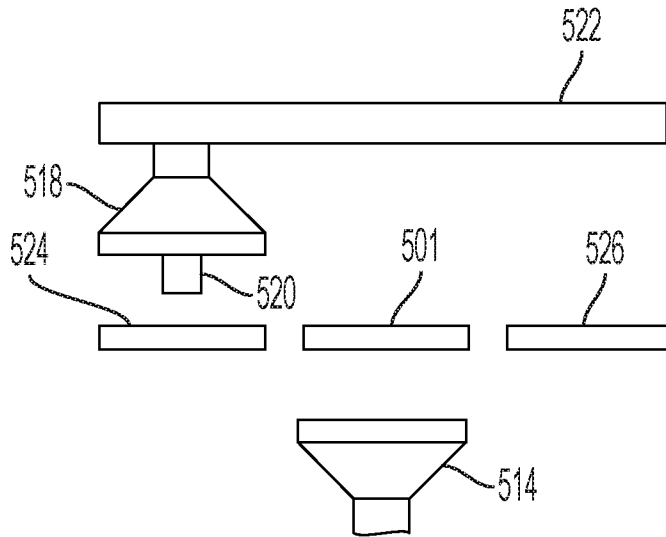

FIG. 59B

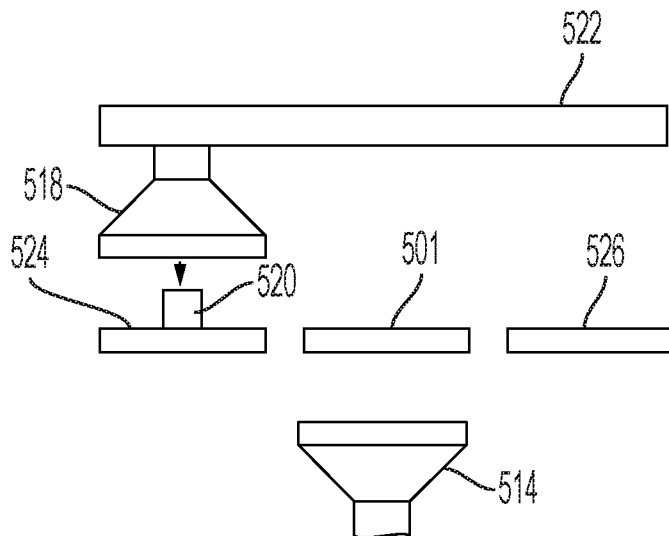

FIG. 59C

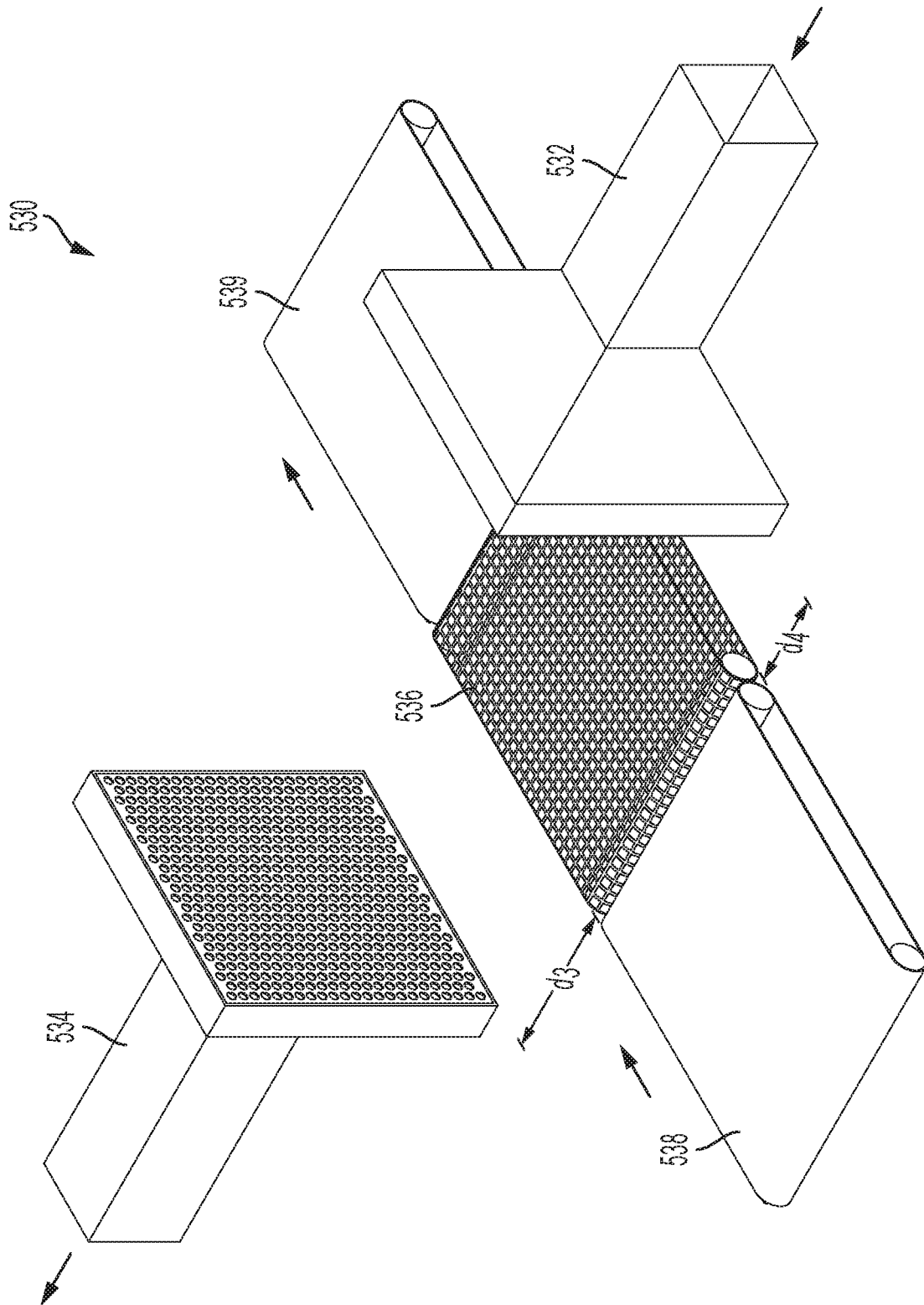

FIG. 60

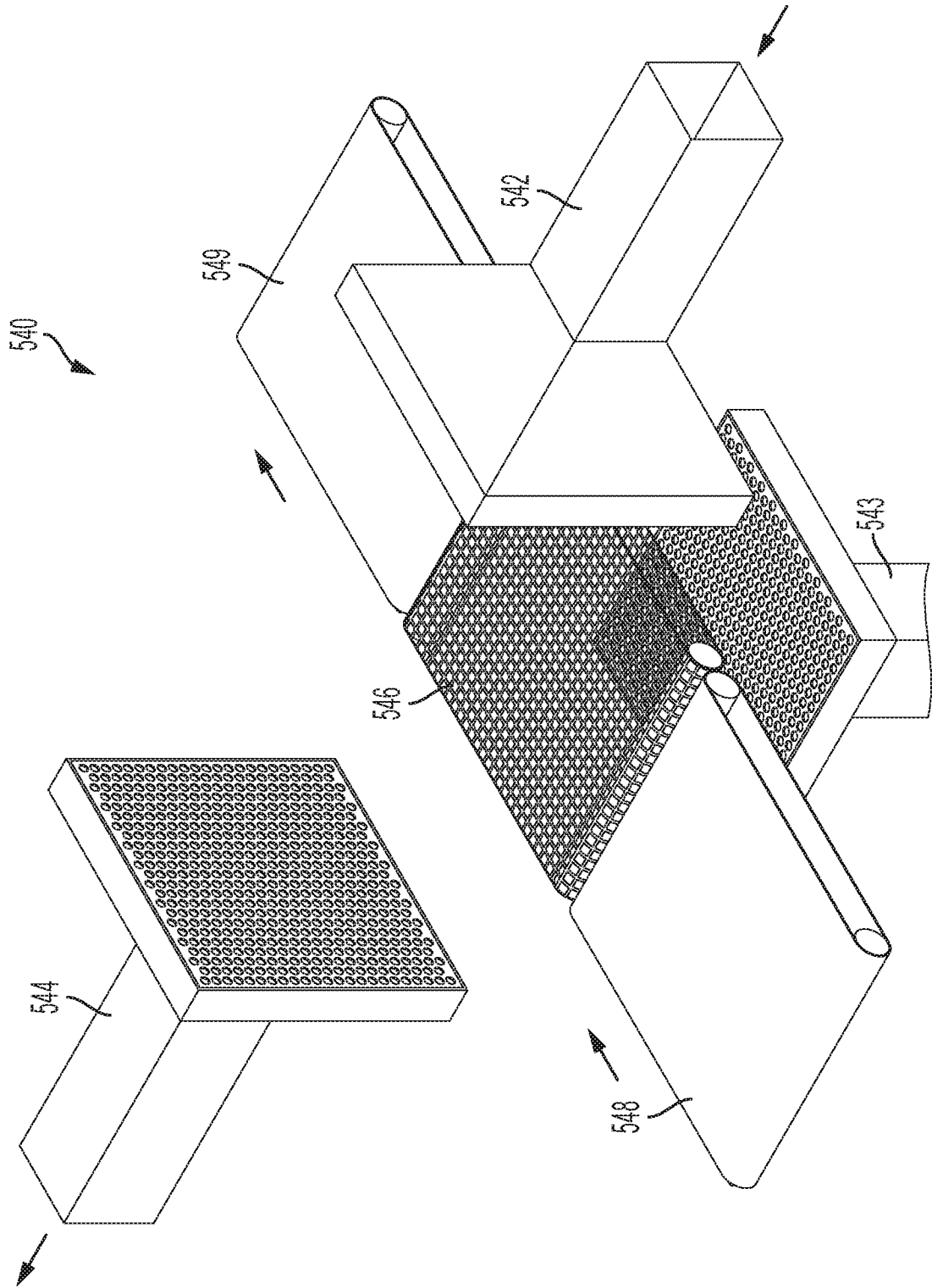

FIG. 61

56/69

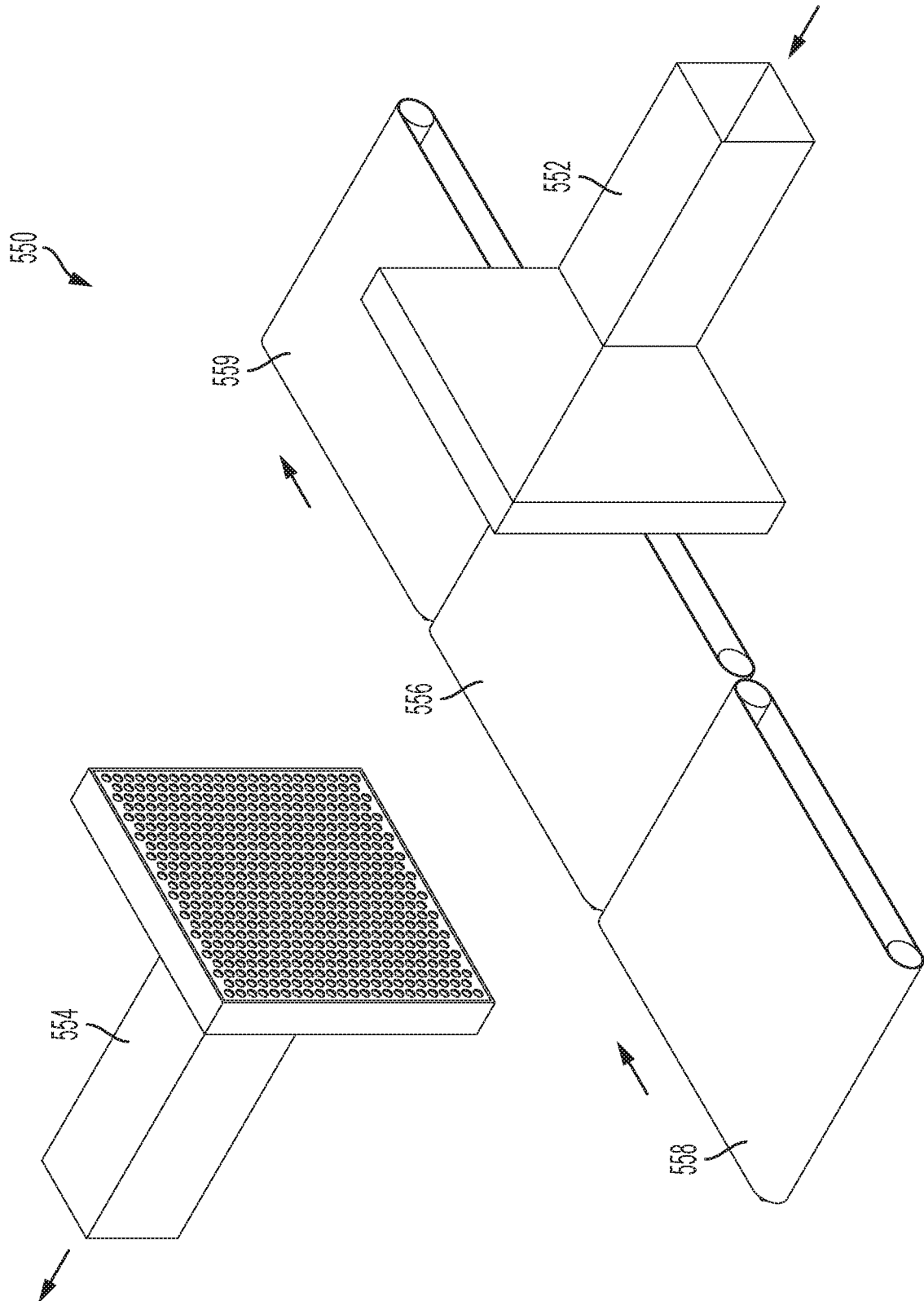

FIG. 62

57/69

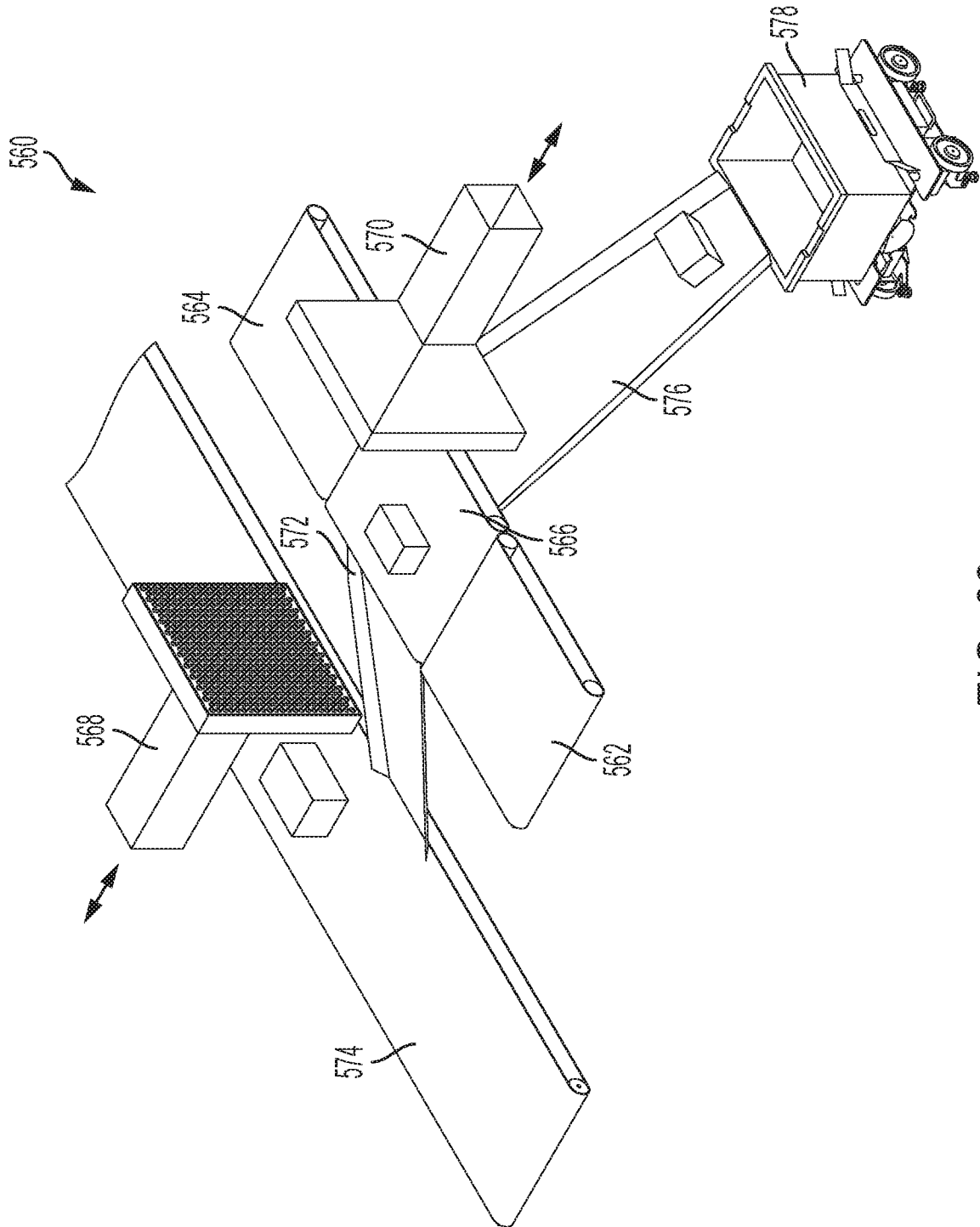

FIG. 63

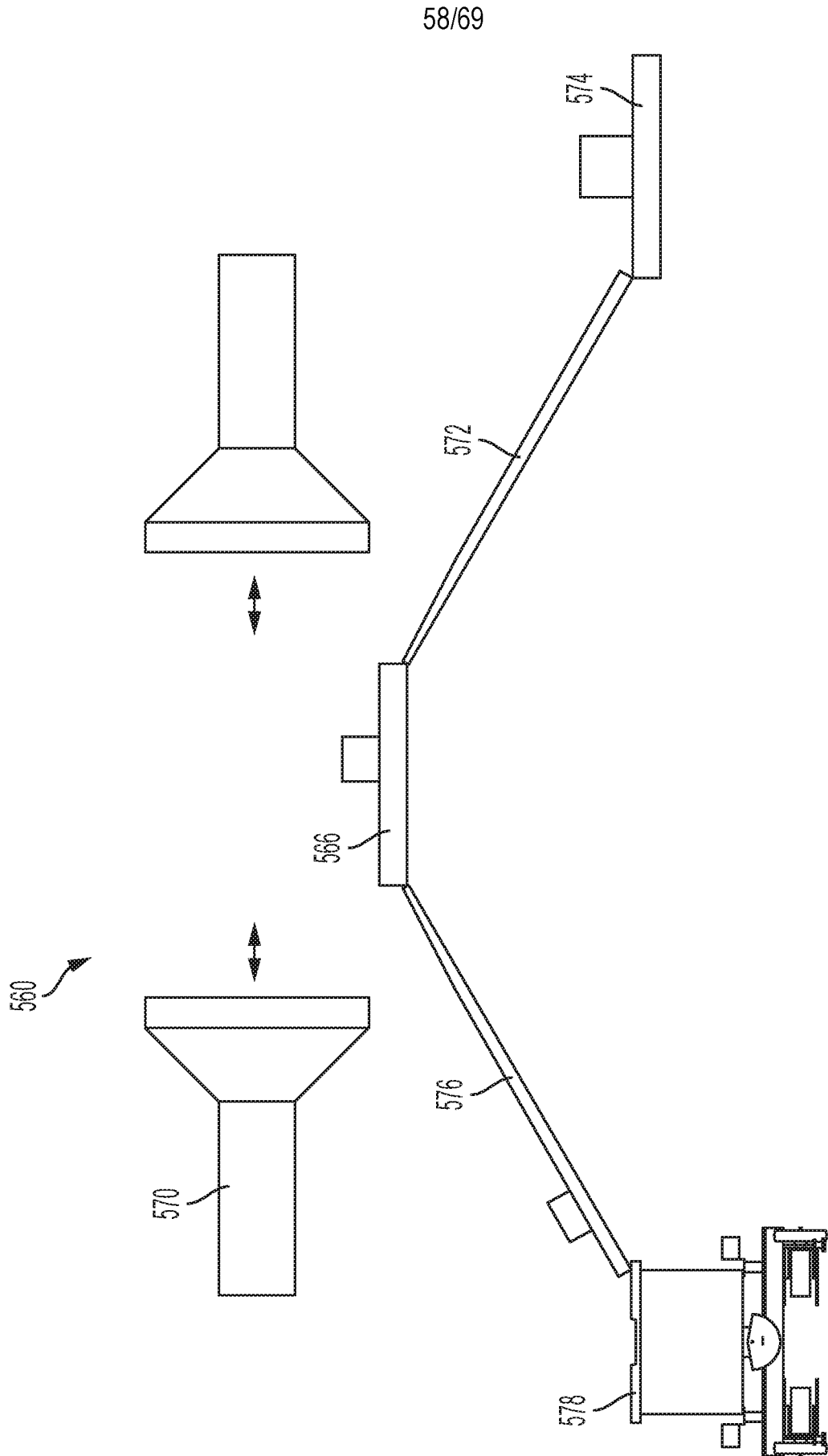

FIG. 64

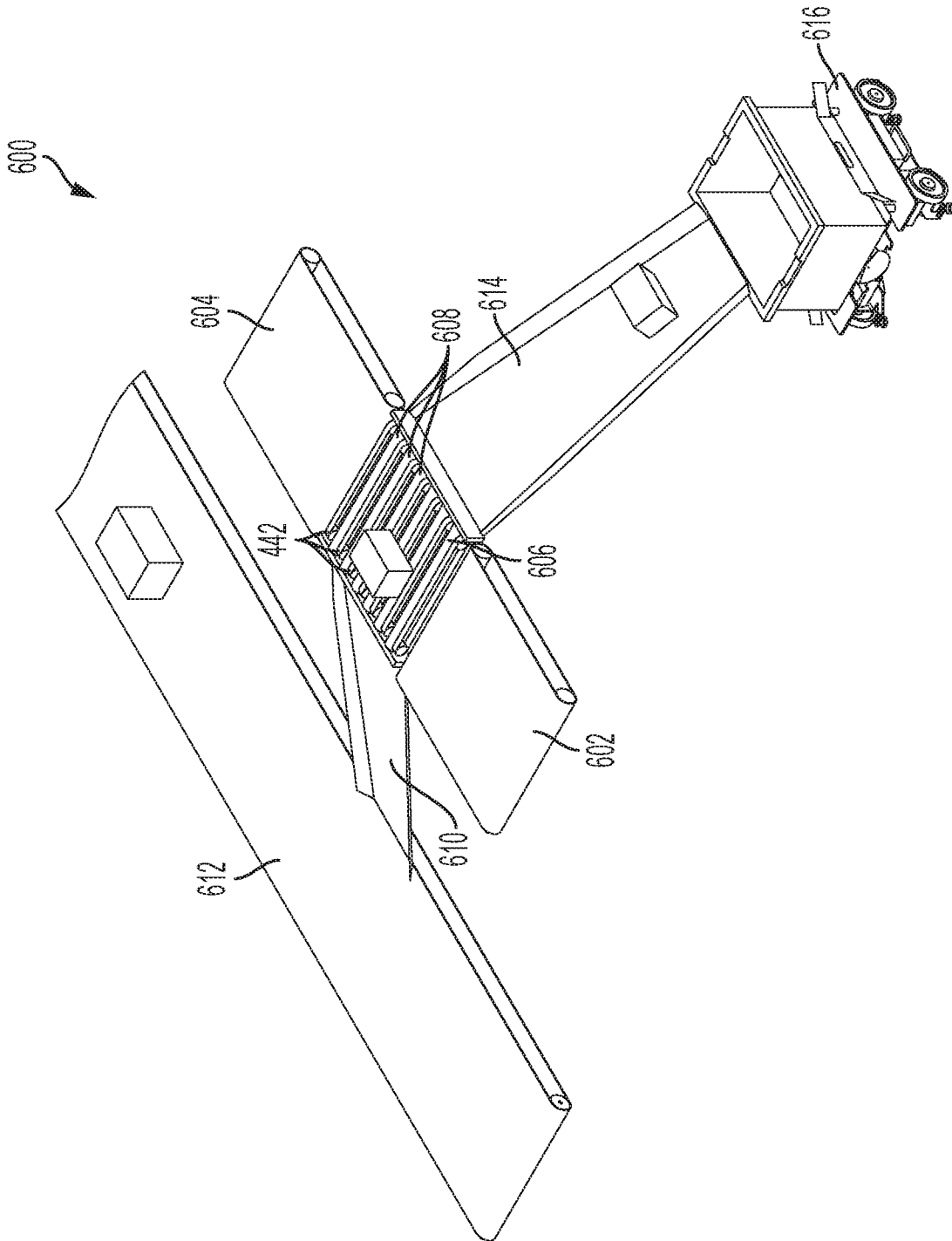

FIG. 65

60/69

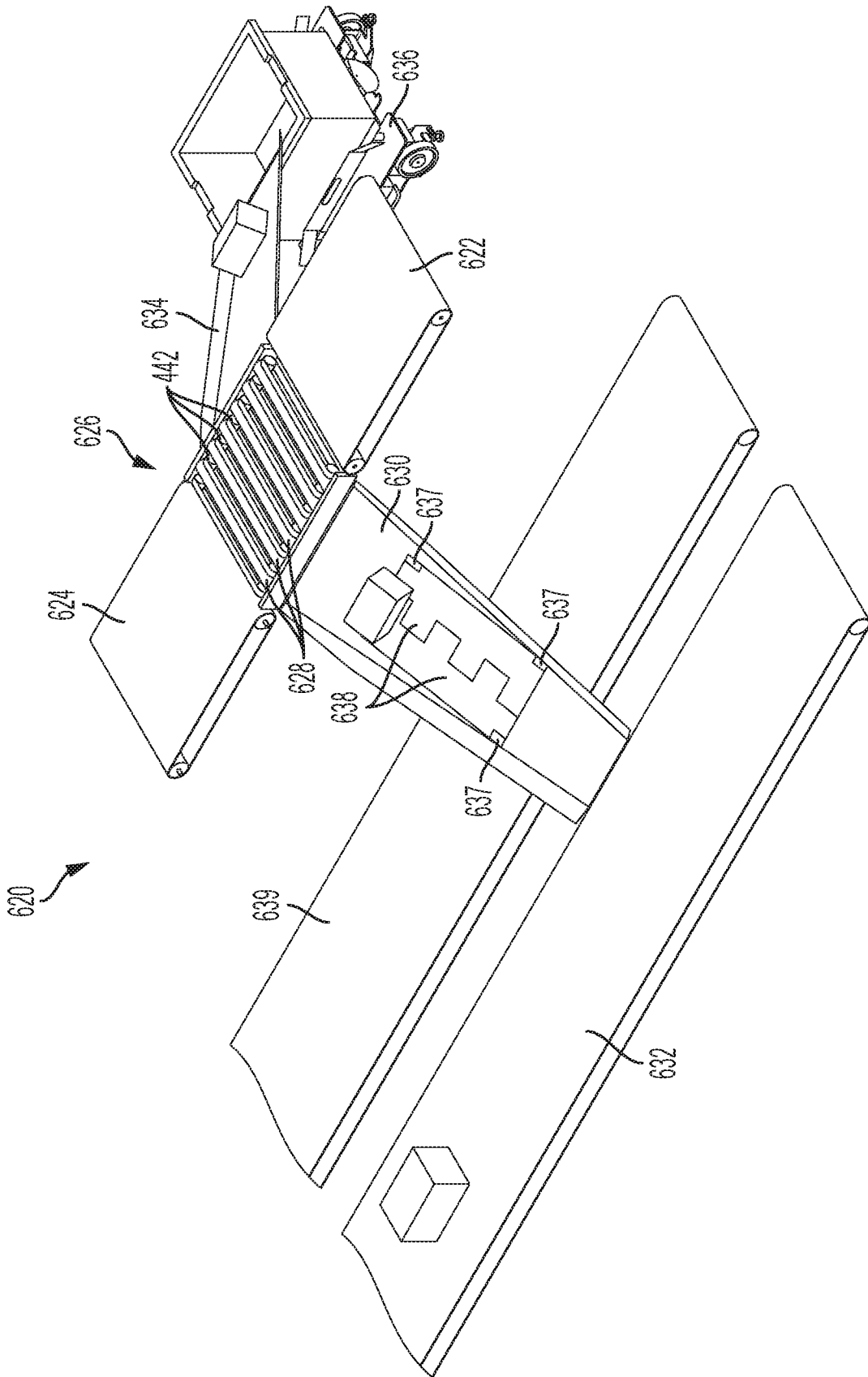

FIG. 66A

61/69

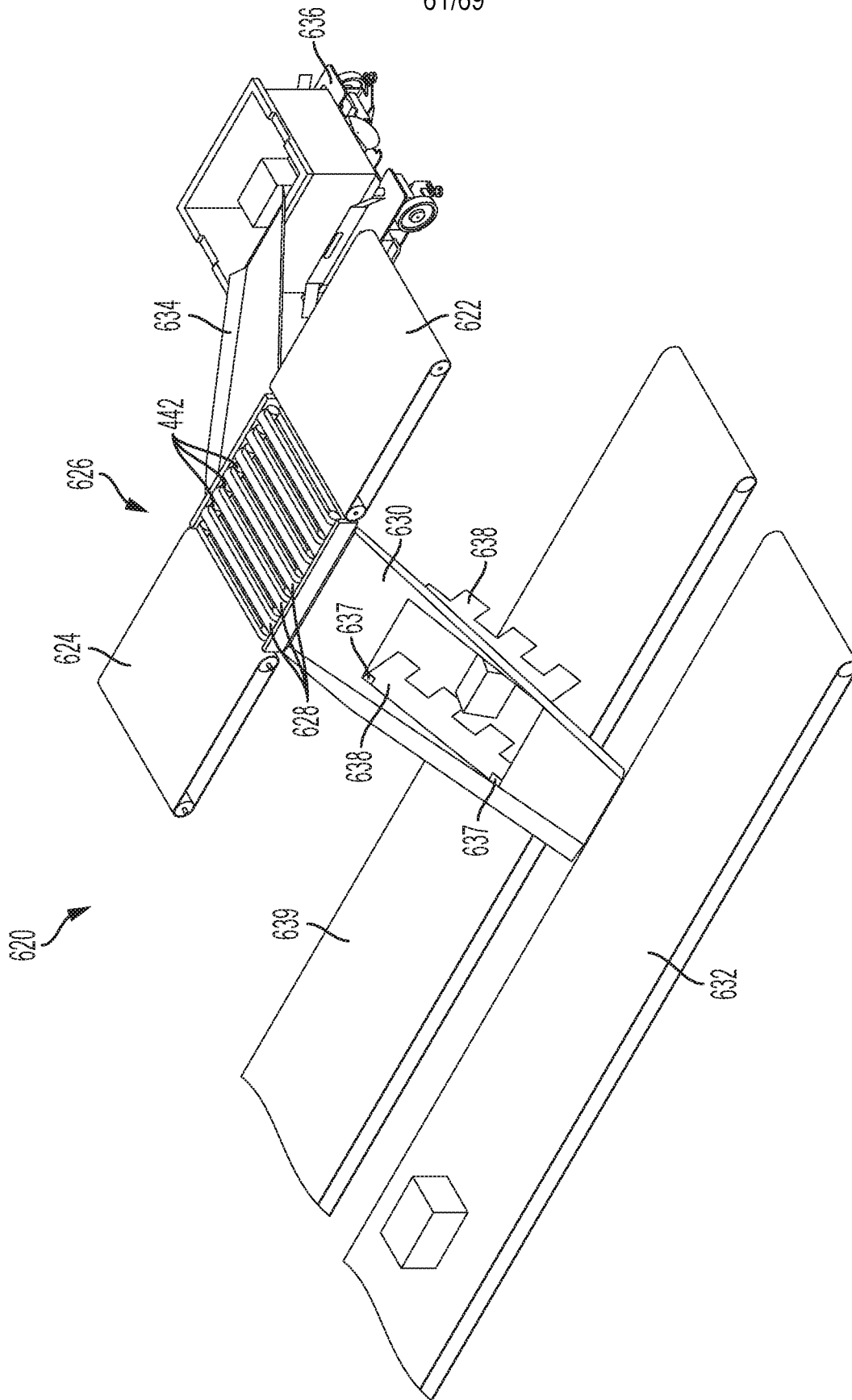

FIG. 66B

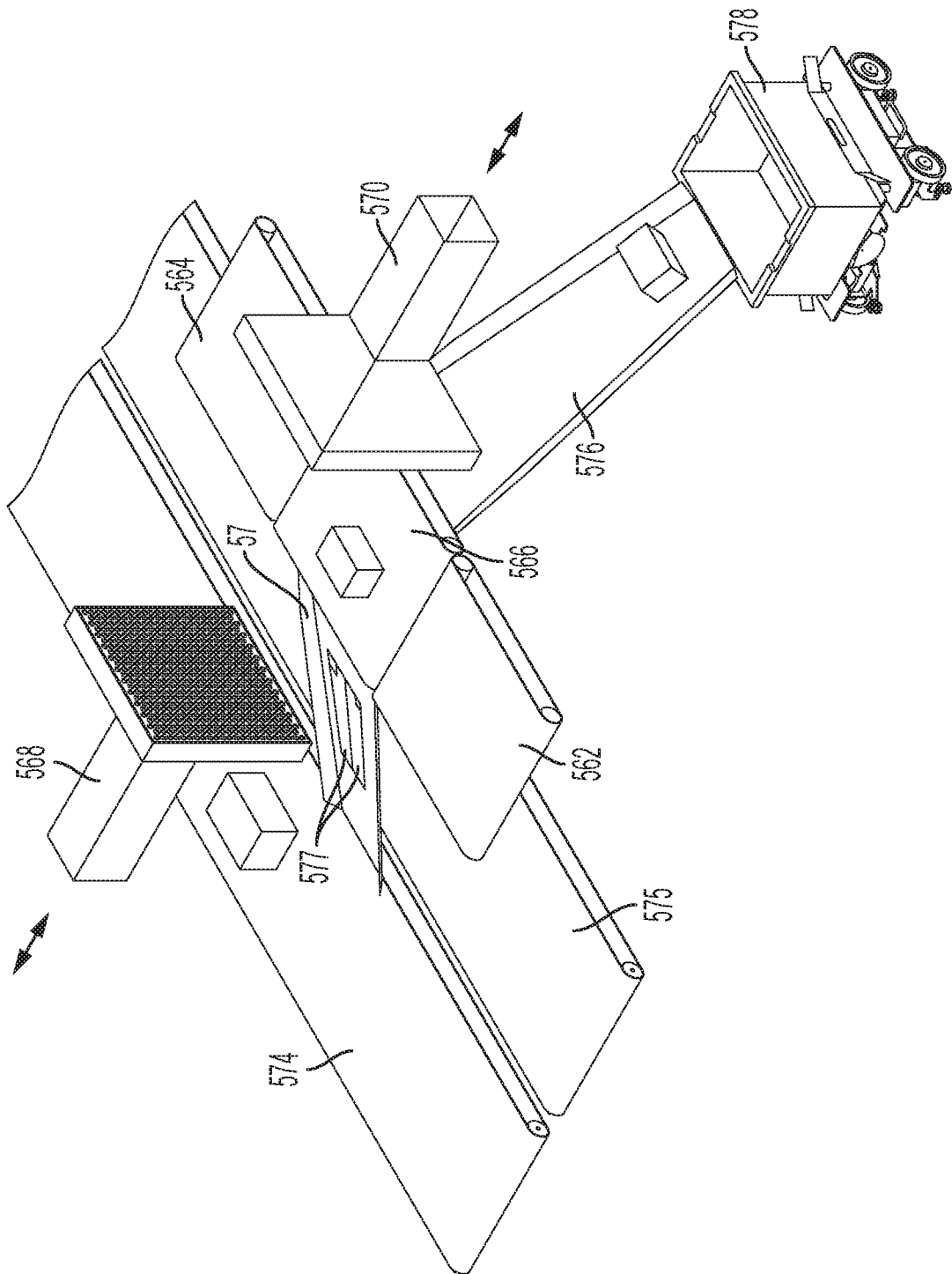

FIG. 67

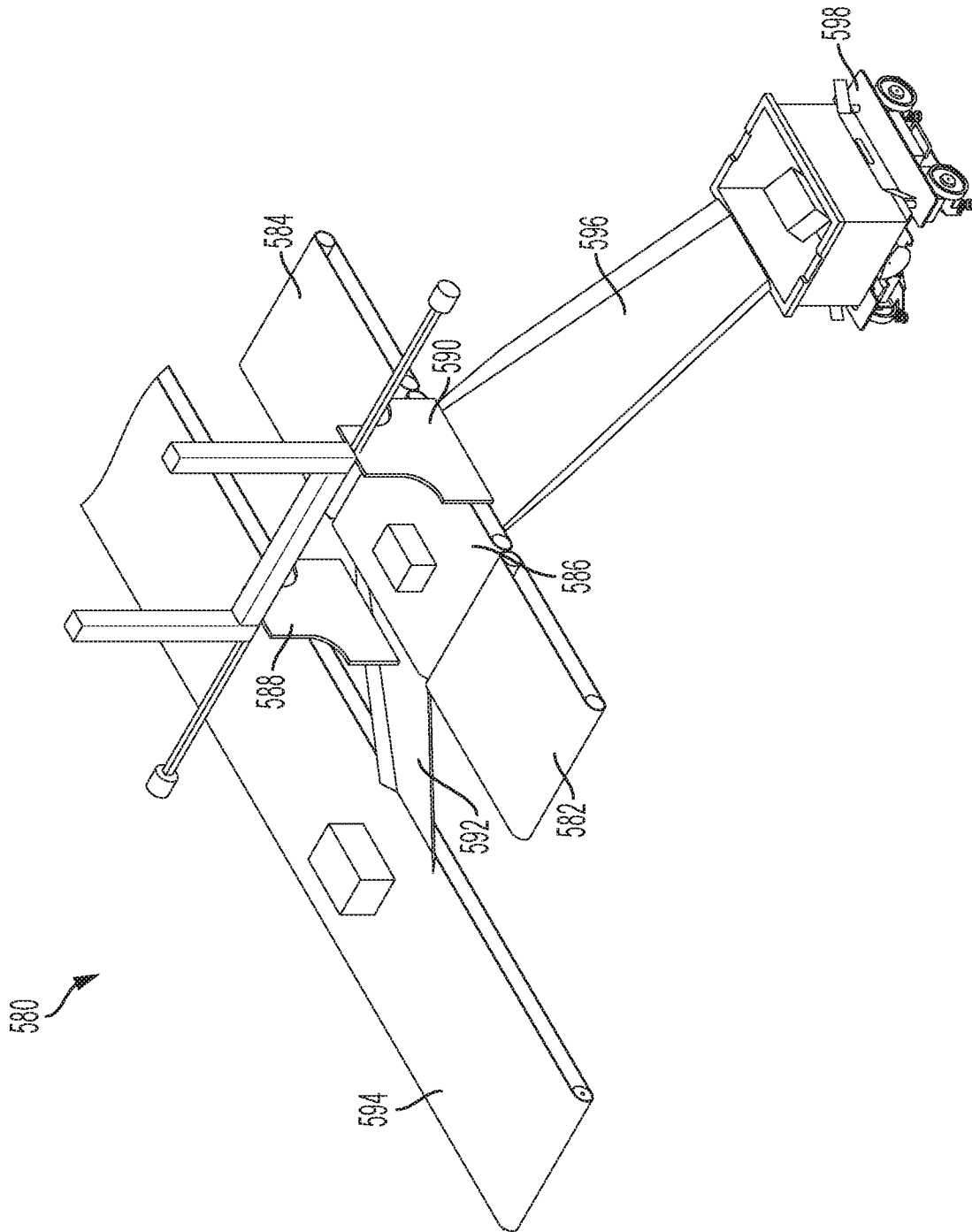

FIG. 68A

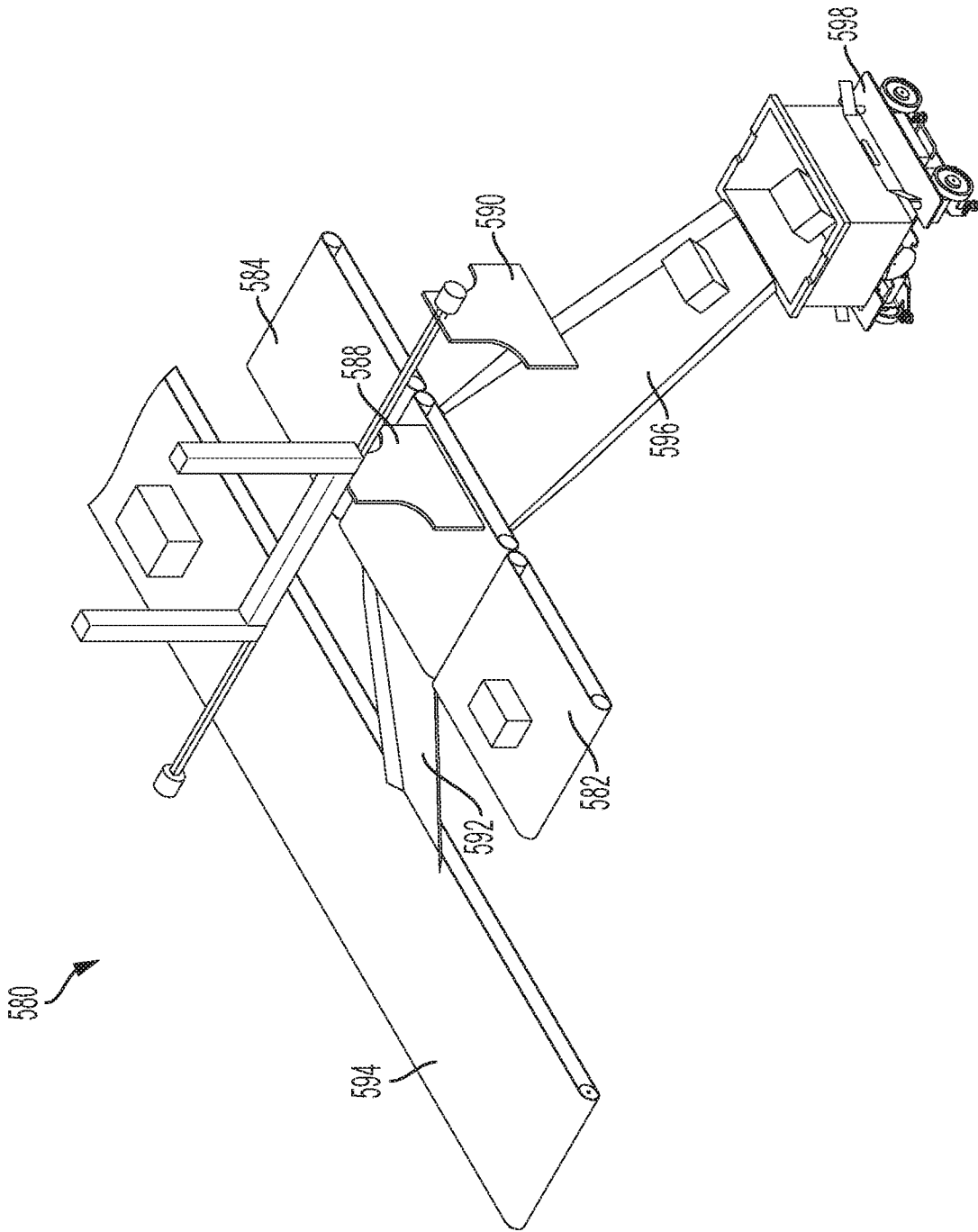

FIG. 68B

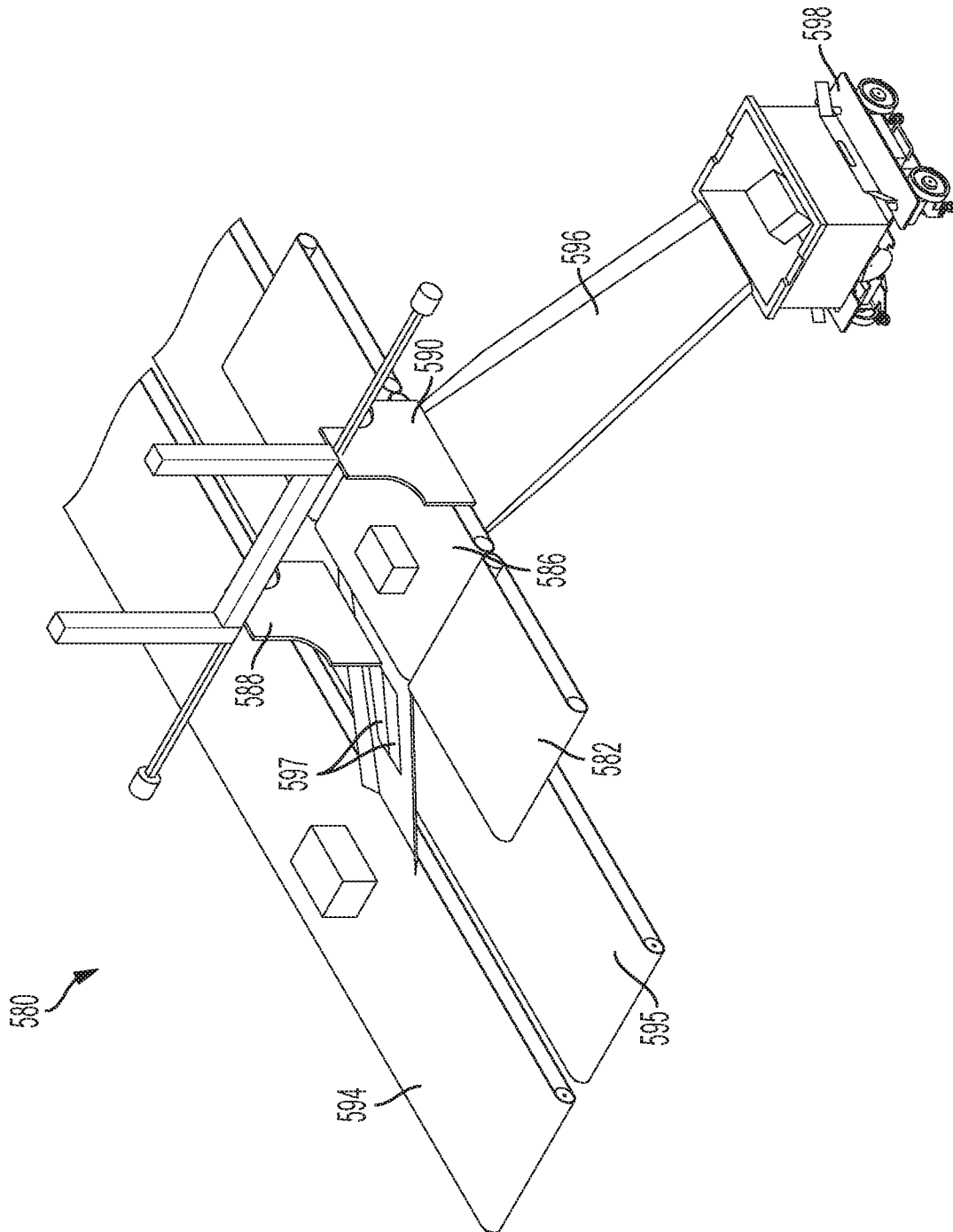

FIG. 69

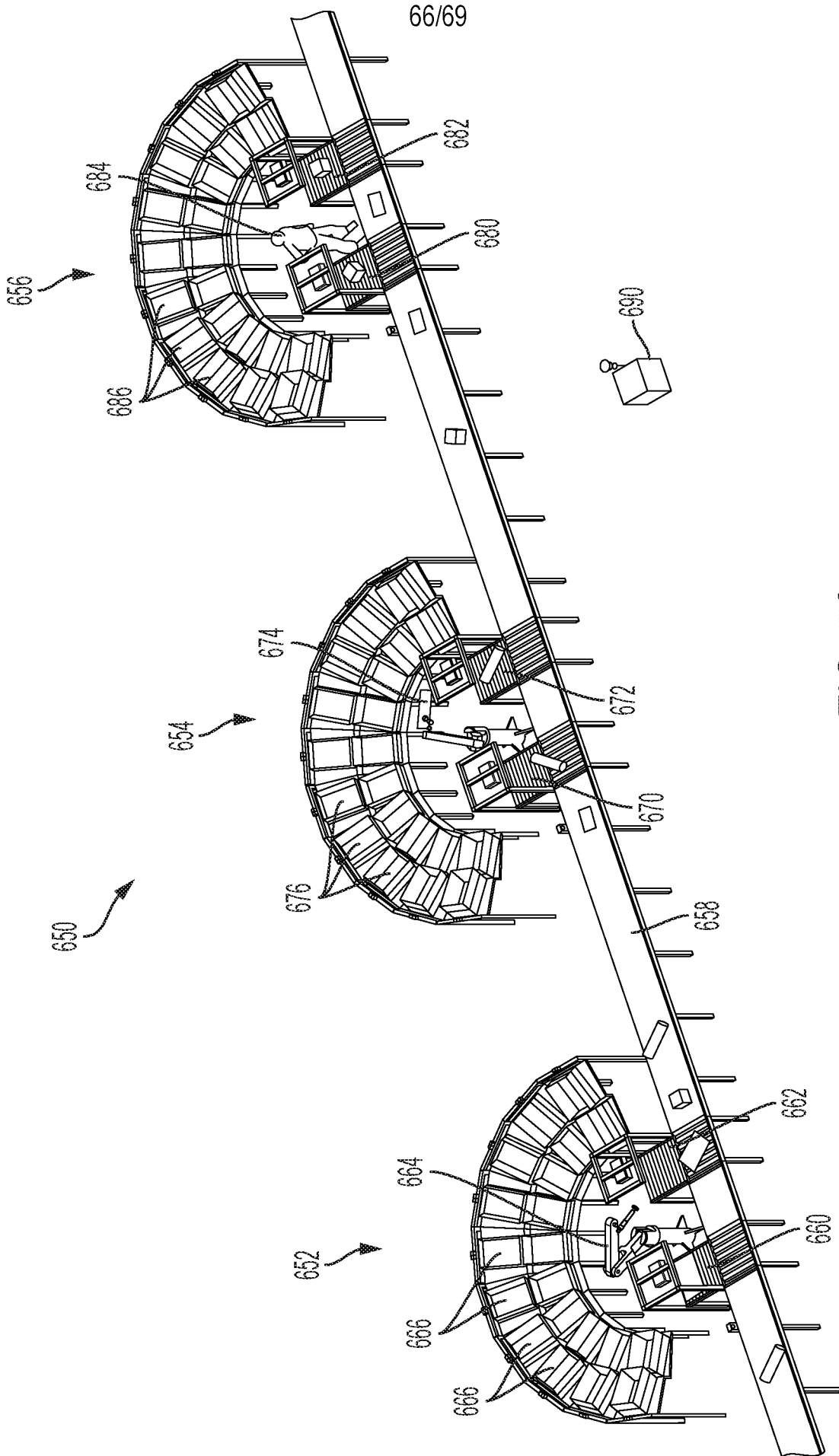

FIG. 70

67/69

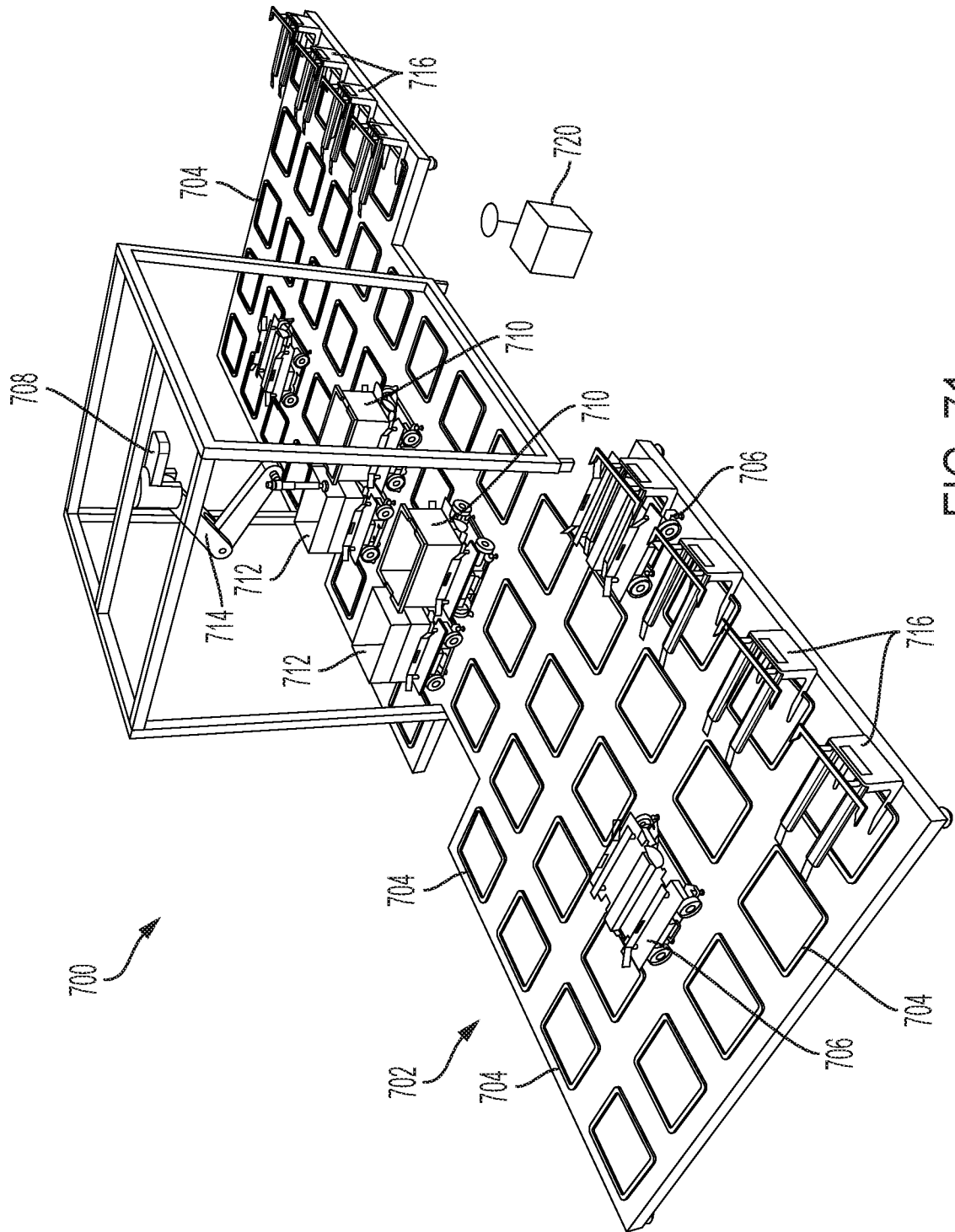

FIG. 71

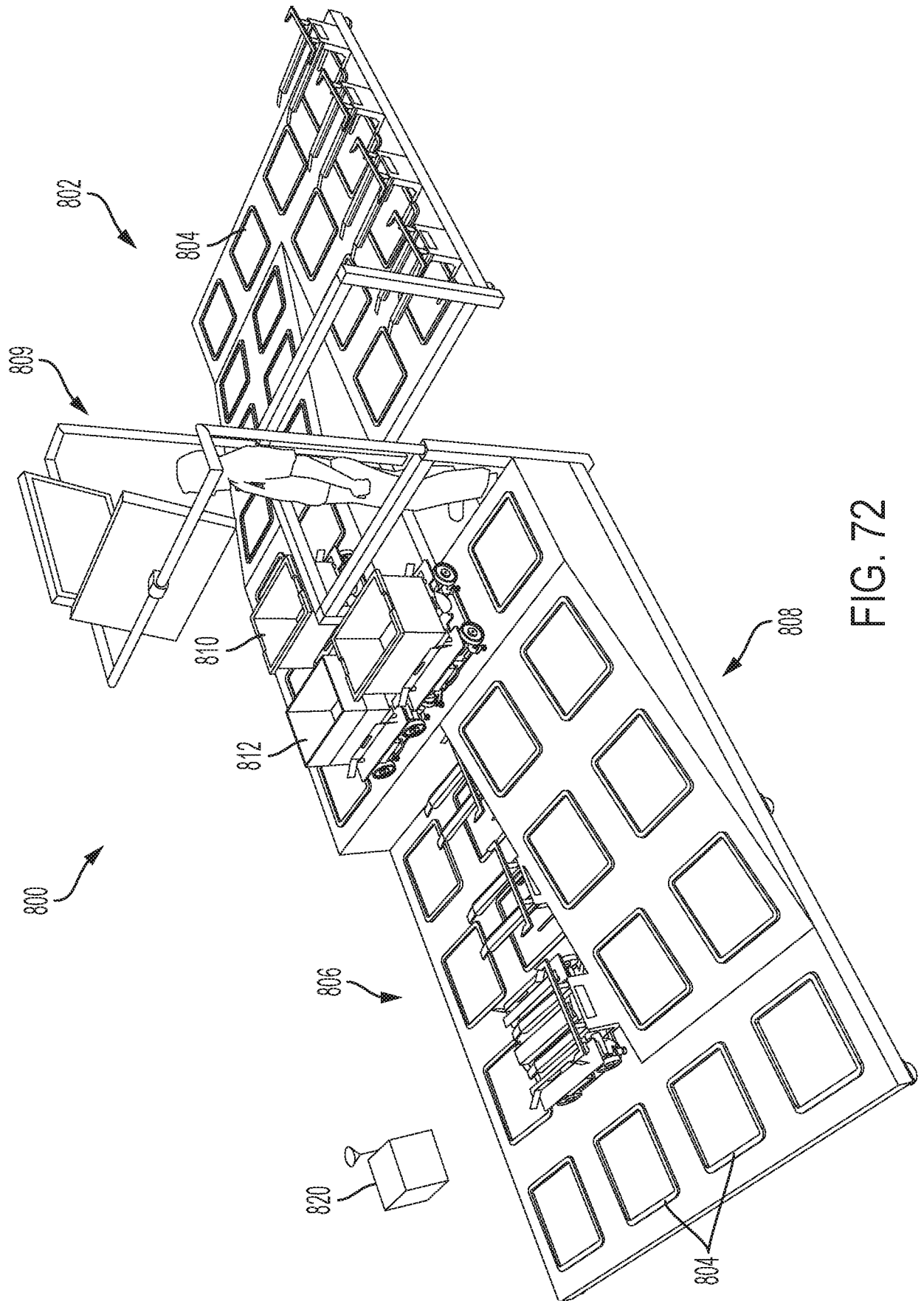

FIG. 72

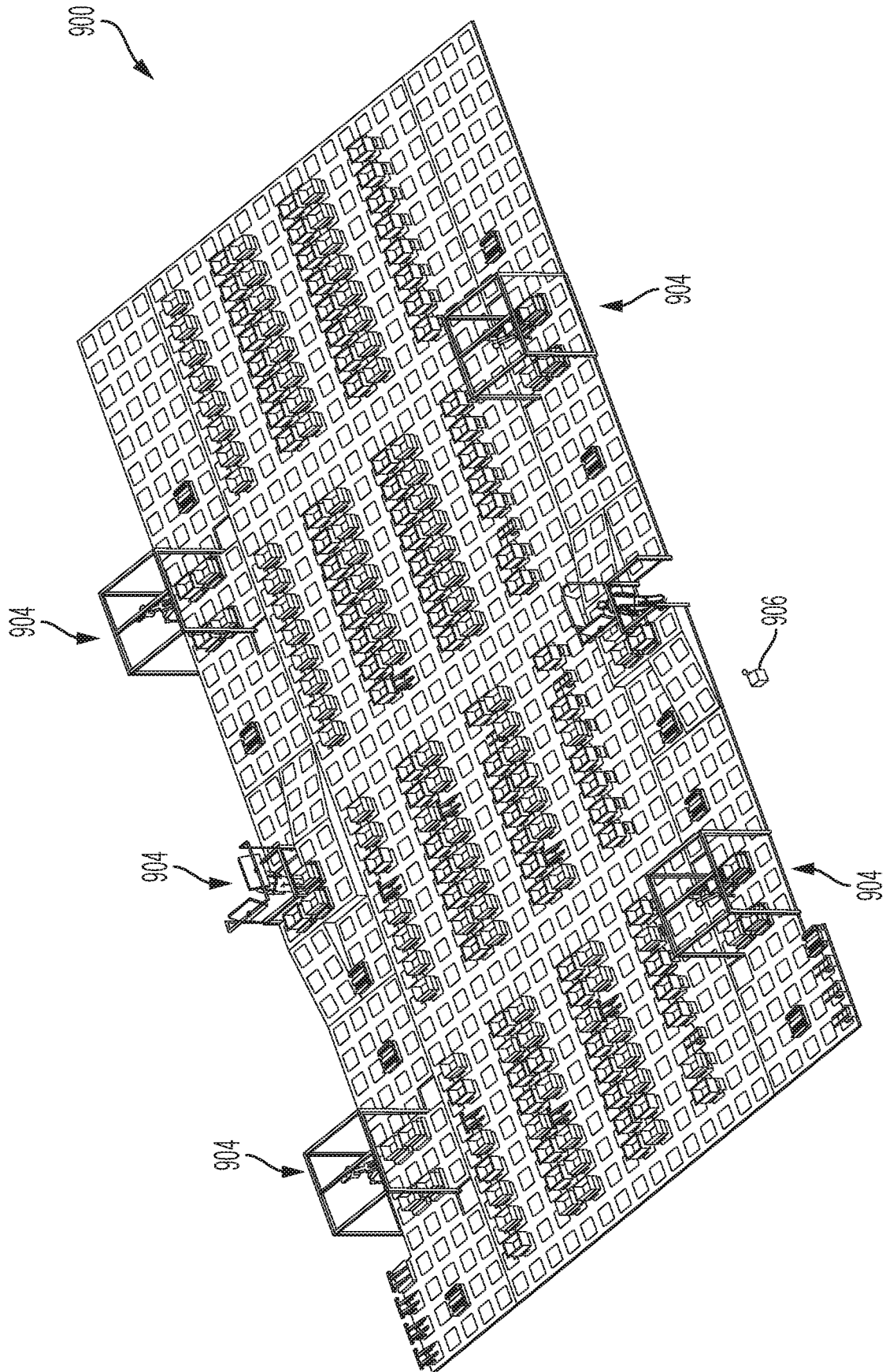

FIG. 73

INTERNATIONAL SEARCH REPORT

International application No

A. CLASSIFICATION OF SUBJECT MATTER
 INV. G06Q10/00 G06Q10/08 G06Q50/28 G06Q50/30
 ADD.
 According to International Patent Classification (IPC) or to both national classification and IPC

B. FIELDS SEARCHED
 Minimum documentation searched (classification system followed by classification symbols)
 G06Q
 Documentation searched other than minimum documentation to the extent that such documents are included in the fields searched

Electronic data base consulted during the international search (name of data base and, where practicable, search terms used)
 EPO-Internal, WPI Data

C. DOCUMENTS CONSIDERED TO BE RELEVANT

Category*	Citation of document, with indication, where appropriate, of the relevant passages	Relevant to claim No.
X	US 2018/282065 A1 (WAGNER THOMAS [US] ET AL) 4 October 2018 (2018-10-04) abstract paragraph [0007] - paragraph [0011] paragraph [0031] - paragraph [0033] paragraph [0039] - paragraph [0046] -----	1-35
X	US 2018/127219 A1 (WAGNER THOMAS [US] ET AL) 10 May 2018 (2018-05-10) abstract; figure 1 figures 1,6 paragraph [0012] - paragraph [0018] paragraph [0043] - paragraph [0045] paragraph [0072] - paragraph [0077] ----- -/--	1-35

Further documents are listed in the continuation of Box C.

See patent family annex.

* Special categories of cited documents :

- "A" document defining the general state of the art which is not considered to be of particular relevance
- "E" earlier application or patent but published on or after the international filing date
- "L" document which may throw doubts on priority claim(s) or which is cited to establish the publication date of another citation or other special reason (as specified)
- "O" document referring to an oral disclosure, use, exhibition or other means
- "P" document published prior to the international filing date but later than the priority date claimed

- "T" later document published after the international filing date or priority date and not in conflict with the application but cited to understand the principle or theory underlying the invention
- "X" document of particular relevance; the claimed invention cannot be considered novel or cannot be considered to involve an inventive step when the document is taken alone
- "Y" document of particular relevance; the claimed invention cannot be considered to involve an inventive step when the document is combined with one or more other such documents, such combination being obvious to a person skilled in the art
- "&" document member of the same patent family

Date of the actual completion of the international search 17 March 2020	Date of mailing of the international search report 25/03/2020
--	--

Name and mailing address of the ISA/ European Patent Office, P.B. 5818 Patentlaan 2 NL - 2280 HV Rijswijk Tel. (+31-70) 340-2040, Fax: (+31-70) 340-3016	Authorized officer Anastasov, Yuliyen
--	--

INTERNATIONAL SEARCH REPORT

International application No

C(Continuation). DOCUMENTS CONSIDERED TO BE RELEVANT

Category*	Citation of document, with indication, where appropriate, of the relevant passages	Relevant to claim No.
X	US 2017/225330 A1 (WAGNER THOMAS [US] ET AL) 10 August 2017 (2017-08-10) abstract; figures 1-3 paragraph [0028] - paragraph [0030] paragraph [0032] - paragraph [0037] paragraph [0050] - paragraph [0052] -----	1-35
X	US 2004/215480 A1 (KADABA NAGESH [US]) 28 October 2004 (2004-10-28) abstract; figure 1 paragraph [0007] - paragraph [0011] paragraph [0013] - paragraph [0021] paragraph [0025] - paragraph [0030] paragraph [0093] - paragraph [0108] -----	1-35

INTERNATIONAL SEARCH REPORT

Information on patent family members

International application No

Patent document cited in search report	Publication date	Patent family member(s)	Publication date
US 2018282065 A1	04-10-2018	CA 3056922 A1	27-09-2018
		CN 110462657 A	15-11-2019
		EP 3602437 A1	05-02-2020
		US 2018282065 A1	04-10-2018
		WO 2018175717 A1	27-09-2018

US 2018127219 A1	10-05-2018	CA 3043018 A1	17-05-2018
		CN 110199231 A	03-09-2019
		EP 3538961 A1	18-09-2019
		US 2018127219 A1	10-05-2018
		WO 2018089486 A1	17-05-2018

US 2017225330 A1	10-08-2017	CA 3014049 A1	17-08-2017
		CN 108778636 A	09-11-2018
		EP 3414060 A1	19-12-2018
		US 2017225330 A1	10-08-2017
		US 2019314988 A1	17-10-2019
		US 2019329410 A1	31-10-2019
		WO 2017139330 A1	17-08-2017

US 2004215480 A1	28-10-2004	CA 2523453 A1	04-11-2004
		CA 2893502 A1	04-11-2004
		EP 1615731 A2	18-01-2006
		JP 2006524622 A	02-11-2006
		MX PA05011414 A	02-02-2006
		US 2004215480 A1	28-10-2004
		US 2010223173 A1	02-09-2010
		US 2011029447 A1	03-02-2011
		US 2011125664 A1	26-05-2011
		US 2011125665 A1	26-05-2011
		US 2014207701 A1	24-07-2014
		US 2014207702 A1	24-07-2014
		US 2015081584 A1	19-03-2015
		US 2015081585 A1	19-03-2015
		WO 2004095338 A2	04-11-2004
