

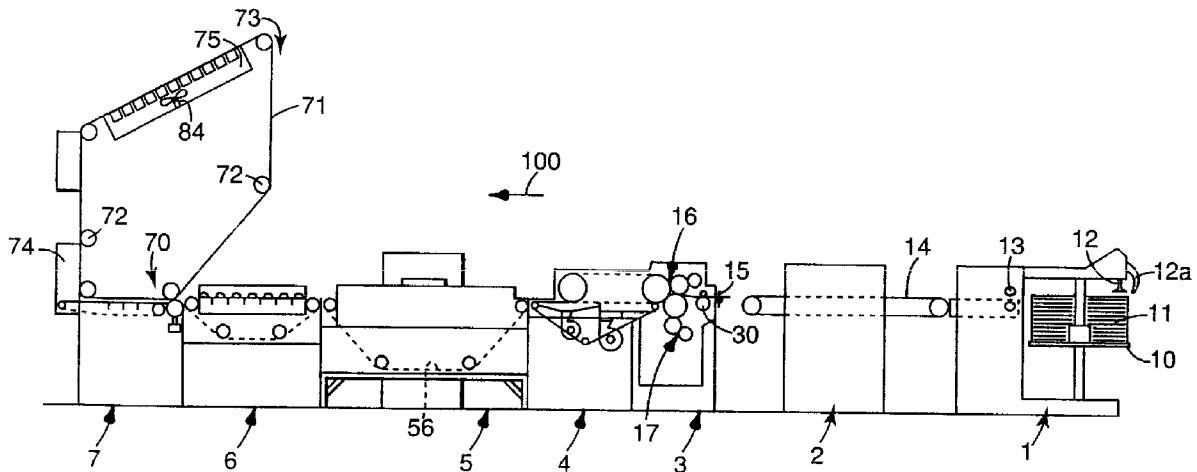

- (72) BRANCH, Don E., US
(72) LE RICHE, Frederic P.A., US
(72) PIERRE, Bernard R., US
(71) MINNESOTA MINING AND MANUFACTURING COMPANY, US
(51) Int.Cl.⁶ B65H 3/44, B65H 5/24, B05C 1/08, B65H 39/04, B05C 13/00
(30) 1996/02/16 (96.03281.8) GB
(30) 1996/02/16 (96.03345.1) GB
(30) 1996/02/16 (96.03355.0) GB
(30) 1996/02/16 (96.03365.9) GB
(30) 1996/02/16 (96.03366.7) GB

(54) **APPAREIL ET PROCÉDE AMÉLIORÉS POUR LE COUCHAGE
DE SUBSTANCES DE REVÊTEMENT SUR DES FEUILLES
INDIVIDUELLES**

(54) **IMPROVED APPARATUS AND METHOD FOR APPLYING
COATING MATERIALS TO INDIVIDUAL SHEET MEMBERS**



(57) Un distributeur (1) amène des feuilles à revêtir d'une substance de revêtement à base d'eau, un apprêt et une colle à faible adhérence par exemple, ces feuilles se chevauchant bout-à-bout, à une machine à enduire recto verso (3) dans laquelle les feuilles sont pourvues, individuellement et sur leurs deux faces, d'un

(57) Sheets to be coated with water-based coating material, for example a primer and a low adhesion backsize, are supplied from a feeder (1), in end-to-end overlapping relationship, to a dual coater (3) in which the sheets are coated individually on both sides. A sheet inserter (2) is provided, upstream of the dual coater, to



(21) (A1) **2,247,303**
(86) 1996/11/01
(87) 1997/08/21

revêtement. L'appareil comporte, en amont du distributeur, un introducteur de feuilles (2) destiné à introduire des feuilles en provenance d'un second dispositif d'approvisionnement auprès des feuilles provenant du distributeur (1). Les feuilles couchées recto verso sont mises à sécher, individuellement ou sous la forme d'une pseudo-bande constituée de feuilles se chevauchant. On les fait ensuite se chevaucher, à moins que ceci n'ait déjà été fait, et l'on change, si nécessaire, le sens de chevauchement afin de placer le bord arrière de chaque feuille sur le dessus du bord avant de chaque feuille suivante. On fait traverser aux feuilles se chevauchant un poste de transfert d'adhésif (7) dans lequel des bandes (236) d'un adhésif séché, du moins partiellement, provenant d'une courroie de transfert (71), sont apposées sur les deux feuilles pourvues de revêtement.

insert sheets from a second supply into the sheets from the feeder (1). The dual coated sheets are dried as individual sheets or as a pseudo-web of overlapped sheets. The sheets are then overlapped, unless previously overlapped, and the direction of overlap changed, if necessary, to provide the trailing edge of each sheet on top of the leading edge of each succeeding sheet. The overlapped sheets are conveyed through an adhesive transfer station (7) where stripes (236) of at least partially dried adhesive are coated onto the dual coated sheets form a transfer belt (71).



PCT

WORLD INTELLECTUAL PROPERTY ORGANIZATION
International Bureau

INTERNATIONAL APPLICATION PUBLISHED UNDER THE PATENT COOPERATION TREATY (PCT)

<p>(51) International Patent Classification ⁶ : B65H 3/44, 5/24, 39/04, B05C 13/00, 9/14, B65H 29/66, B05C 1/08, 9/04</p>	<p>A1</p>	<p>(11) International Publication Number: WO 97/29985 (43) International Publication Date: 21 August 1997 (21.08.97)</p>
<p>(21) International Application Number: PCT/US96/17575 (22) International Filing Date: 1 November 1996 (01.11.96) (30) Priority Data: 9603365.9 16 February 1996 (16.02.96) GB 9603366.7 16 February 1996 (16.02.96) GB 9603281.8 16 February 1996 (16.02.96) GB 9603345.1 16 February 1996 (16.02.96) GB 9603355.0 16 February 1996 (16.02.96) GB (71) Applicant: MINNESOTA MINING AND MANUFACTURING COMPANY [US/US]; 3M Center, P.O. Box 33427, Saint Paul, MN 55133-3427 (US). (72) Inventors: BRANCH, Don, E.; P.O. Box 33427, Saint Paul, MN 55133-3427 (US). LE RICHE, Frederic, P., A.; P.O. Box 33427, Saint Paul, MN 55133-3427 (US). PIERRE, Bernard, R.; P.O. Box 33427, Saint Paul, MN 55133-3427 (US). (74) Agents: PETERS, Carolyn, V. et al.; Minnesota Mining and Manufacturing Company, Office of Intellectual Property Counsel, P.O. Box 33427, Saint Paul, MN 55133-3427 (US).</p>	<p>(81) Designated States: AL, AM, AT, AU, AZ, BA, BB, BG, BR, BY, CA, CH, CN, CU, CZ, DE, DK, EE, ES, FI, GB, GE, HU, IL, IS, JP, KE, KG, KP, KR, KZ, LC, LK, LR, LS, LT, LU, LV, MD, MG, MK, MN, MW, MX, NO, NZ, PL, PT, RO, RU, SD, SE, SG, SI, SK, TJ, TM, TR, TT, UA, UG, UZ, VN, ARIPO patent (KE, LS, MW, SD, SZ, UG), Eurasian patent (AM, AZ, BY, KG, KZ, MD, RU, TJ, TM), European patent (AT, BE, CH, DE, DK, ES, FI, FR, GB, GR, IE, IT, LU, MC, NL, PT, SE), OAPI patent (BF, BJ, CF, CG, CI, CM, GA, GN, ML, MR, NE, SN, TD, TG).</p> <p>Published <i>With international search report.</i> <i>With amended claims.</i></p>	

(54) Title: IMPROVED APPARATUS AND METHOD FOR APPLYING COATING MATERIALS TO INDIVIDUAL SHEET MEMBERS

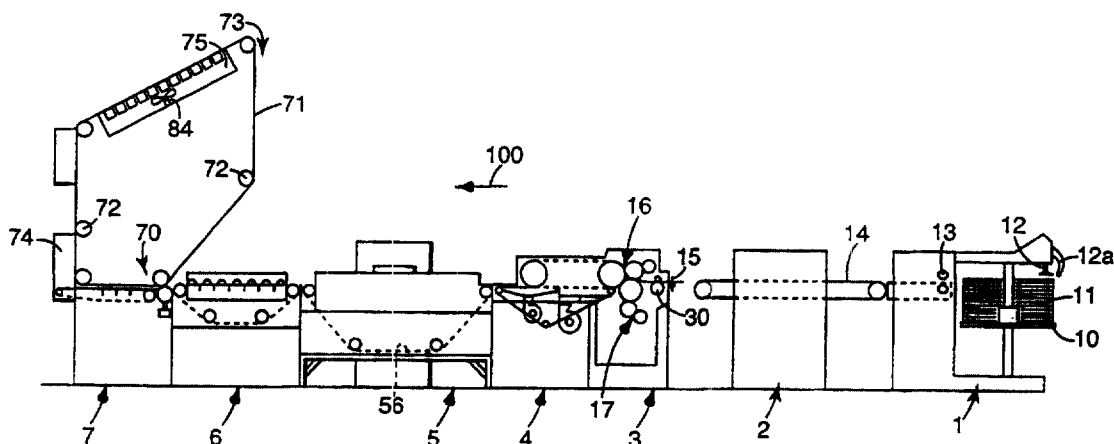

(57) Abstract

Sheets to be coated with water-based coating material, for example a primer and a low adhesion backsize, are supplied from a feeder (1), in end-to-end overlapping relationship, to a dual coater (3) in which the sheets are coated individually on both sides. A sheet inserter (2) is provided, upstream of the dual coater, to insert sheets from a second supply into the sheets from the feeder (1). The dual coated sheets are dried as individual sheets or as a pseudo-web of overlapped sheets. The sheets are then overlapped, unless previously overlapped, and the direction of overlap changed, if necessary, to provide the trailing edge of each sheet on top of the leading edge of each succeeding sheet. The overlapped sheets are conveyed through an adhesive transfer station (7) where stripes (236) of at least partially dried adhesive are coated onto the dual coated sheets form a transfer belt (71).

**IMPROVED APPARATUS AND METHOD
FOR APPLYING COATING MATERIALS
TO INDIVIDUAL SHEET MEMBERS**

5

FIELD OF THE INVENTION

The present invention relates generally to an apparatus and method for applying coating materials to a plurality of overlapped individual sheets, such as individual sheets of paper. A specific aspect of the invention relates to an apparatus and method for applying a coating material to both opposing major surfaces of a plurality of individual sheets.

10

BACKGROUND

It is often necessary to apply coating materials to paper and, in some cases, to apply different coating materials to both major surfaces of the paper. For example, in the production of repositionable notes, such as the Post-It® brand note pads available from Minnesota Mining and Manufacturing Company, it is known to apply a primer material to one side of the paper from which the repositionable notes will be cut, and to apply a low adhesion backsize, or release, material to the other side of the paper. Repositionable adhesive is then applied to the paper on top of the primer material. Conventionally, for the production of repositionable notes, the various coatings are applied to a web of paper drawn from a continuous roll. The coating materials are dispersed in solvents and coated directly onto the paper web. The web is dried between coatings and then rewound, with the coated roll subsequently cut into sheets which are used to produce the notes.

15

20

A process for the production of repositionable notes, in which a release material and a primer material are coated successively on opposite sides of a paper web, is described in WO-A-87/05315.

25

In some cases, it is desirable to apply coating material to cut sheets rather than to a continuous web of paper. For example, in the production of repositionable notes it is often desirable to have the option of using a stack of preprinted sheets as the supply source, instead of a plain paper web, to extend the flexibility of the production process. In addition, for environmental reasons, there is a desire to move away from the use of environmentally destructive organic solvents in such coating processes, and towards more environmentally friendly water-based materials. It is moreover noted that many inks are soluble in organic solvents, but insoluble in water.

30

WO 94/19419 discloses an apparatus and a method for forming pads of repositionable notes from a stack of uncoated individual paper sheets. The sheets are fed from the stack in an overlapped condition to a coating station in which a continuous layer of a water-based primer material is applied to one major surface of the pseudo web of overlapped sheets, and a continuous layer of a water-based low adhesion backsize (LAB) material is applied simultaneously to the other major surface. The overlapped sheets are then dried and fed to a second coating station in which stripes of repositionable adhesive are transferred from an endless transfer belt to the pseudo web of overlapped sheets onto the surface to which the primer was applied in the first coating station. Thereafter, the sheets are adhered together in a stack and trimmed to form pads of repositionable notes.

Coating of Individual Sheets

In certain coating processes, it may be preferable for sheets to be coated individually rather than in the form of an overlapped pseudo web. However, commercial coating stations are generally designed for coating a continuous web of paper dispensed from a large roll, and cannot accommodate individual sheets.

Hence, efforts continue to develop a commercially viable system that will enable the coating of individual sheets with an effective amount of coating material.

Reversing Direction of Overlap

In certain circumstances, the handling of overlapped individual sheets can be facilitated by reversing the direction of the overlap as the sheets pass through certain segments of the coating process. When such a reversal in the direction of overlap is desired, the apparatus used to achieve the reversal should function reliably for a wide range of sheet sizes, weights and types.

It has been found that existing systems for applying a coating material to sheets, while having their own utility, are not as effective and flexible as desired. It has also been found that existing systems which use an endless transfer surface for applying a coating material to sheets commonly encounter problems in removing the sheets and the coating material from the transfer surface when certain types of coating materials and/or certain types and sizes of sheets are being coated.. Therefore, an improved method and apparatus for applying coating materials onto sheets, including an improved method and apparatus for transferring a coating material from an endless transfer surface to sheets, is desired.

SUMMARY OF THE INVENTION

Inserting Secondary Sheets

The sheet inserter aspect of the present invention provides an apparatus and a method effective for periodically inserting a different secondary sheet into a sequence of overlapped sheets which are to be coated. The apparatus includes (i) a sheet feeder operable to sequentially feed primary sheets from a stack of primary sheets onto a conveyor in end-to-end overlapping relationship to each other, (ii) a sheet inserter operable to insert at least one secondary sheet, from a second stack, into the overlapped primary sheets on the conveyor, and (iii) a coater positioned to receive the overlapped sequence of primary and secondary sheets from the conveyor and operable to apply coating material to at least one major surface of each sheet.

The method comprises the ordered steps of: (a) feeding primary sheets from a first sheet stack onto a sheet path in end-to-end overlapping relationship to each other, (b) conveying the overlapped primary sheets along the sheet path, (c) inserting at least one secondary sheet, from a second sheet stack, into the overlapped primary sheets being conveyed along the sheet path, so as to form a sequence of primary and secondary sheets arranged in end-to-end overlapping relationship to each other, and then (d) applying a coating material to at least one major surface of each of the primary and secondary sheets in the sequence as the sheets continue to be conveyed along the sheet path.

Dual Coating of Individual Sheet Members

The dual coating aspect of the present invention provides an apparatus and a method for simultaneously applying a water-based coating material to both major surfaces of separated individual sheet members. The apparatus includes (i) a dual coating system positioned to sequentially receive single sheet members as the sheet members are conveyed along a sheet path, the coating system comprising first and second coating mechanisms located on opposed sides of the sheet path with each coating mechanism operable to apply a water-based coating material to a major surface of each sheet; (ii) a dryer positioned along the sheet path for removing water from the water-based coating materials applied to the sheets by the coating mechanism, (iii) means for arranging sheets as they exit from the drier in sequential end-to-end overlapping relation, and (iv) a secondary coating mechanism positioned along the sheet path which is effective for receiving the overlapped sheets and applying a secondary coating material to one side of the overlapped sheets.

The method comprises the ordered steps of: (a) sequentially feeding individual sheets from a first sheet stack onto a sheet path, (b) conveying the overlapped primary sheets along the sheet path, (c) applying a water-based coating material to a major surface of each individual sheet being conveyed along the sheet path, (d) drying the coated sheets while continuing to convey the sheets along the sheet path; (e) arranging the dried sheets in sequential end-to-end overlapping relationship to each other, and then (f) continuously applying a second coating material to at least one major surface of each of the arranged sheets as the sheets continue to be conveyed along the sheet path.

10 **Padded Coating Drum**

The covered coating drum aspect of the present invention provides an apparatus and a method for applying a coating material to at least one major surface of separated individual sheet members. The apparatus includes (i) a coating roller; (ii) a support sheet releasably secured over the surface of the coating roller, (iii) an elastomeric covering member adhesively secured to the support sheet which extends over only a portion of the circumference of the coating roller, (iv) a nip roller which cooperates with the coating roller to form a nip only with that portion of the coating roller which is covered with the covering member; (v) a source of coating material, and (vi) a means for applying coating material from the source of coating material to the covering member on the coating roller.

20 The method comprises the ordered steps of: (a) applying coating material from the source of coating material to the covering member on the coating roller, and (b) conveying individual sheets into the nip formed between the coating roller and the nip roller in such a manner that the sheet is registered and aligned with the covering member on the coating roller such that the coating material on the covering member is transferred to the sheet without being transferred to the nip roller.

Reversing Direction of Overlap

The overlap altering aspect of the present invention provides an apparatus and a method for reversing the direction in which the sheets are overlapped. The apparatus includes (a) a first conveyor means for transporting a succession of overlapped sheets wherein the trailing edge of each sheet is positioned underneath the leading edge of the succeeding sheet; (b) a second conveyor means arranged to receive sheets from the first conveyor means; and (c) an arrangement, positioned between the first and second conveyor means, effective for changing the relative overlapping positions of the sheets;

whereby the sheets received by the second conveyor means are arranged with the trailing edge of each sheet positioned over the leading edge of the succeeding sheet. The arrangement effective for changing the relative overlapping positions of the sheets comprises (A) a blower for directing a current of air at the overlapped edges of each pair of sheets so as to move such edge portions away from the plane defined by the succession of sheets, and (B) a means for retarding the subsequent return of the trailing edge of the leading sheet so as to ensure that such trailing edge will consistently be deposited on top of the leading edge of the succeeding sheet.

A preferred embodiment of the overlap altering aspect of the invention positions the overlap altering arrangement between the dual coating system and the dryer of the dual coat aspect of the invention. In this embodiment, the sheets are coated one at a time in the dual coating system and then deposited on a first conveying means with the trailing edge of each sheet positioned underneath the leading edge portion of the succeeding sheet. As the overlapped sheets are transferred from the first conveying means to a second conveying means for transportation into the dryer, the overlap altering arrangement reverses the relative overlapping positions of the sheets whereby the trailing edge of each sheet is positioned on top of the leading edge portion of the succeeding sheet.

The method comprises the ordered steps of: (i) conveying a succession of overlapped sheets on a first conveying means, wherein the trailing edge of each sheet is positioned underneath the leading edge of the succeeding sheet; (ii) transferring the overlapped succession of sheets from the first conveyor means to a second conveyor means; and (iii) changing the relative overlapping positions of the sheets as the sheets are transferred from the first conveying means to the second conveying means so that the sheets received by the second conveyor means are arranged with the trailing edge of each sheet positioned over the leading edge of the succeeding sheet. The preferred means by which the relative overlapping positions of the sheets is changed includes the steps of (I) blowing a current of air at the overlapped edges of each pair of sheets so as to move such edge portions away from the plane defined by the succession of sheets, and then (II) retarding the subsequent return of the trailing edge of the leading sheet so as to ensure that such trailing edge will consistently be deposited on top of the leading edge of the succeeding sheet.

Detachment of Coated Sheets From a Transfer Surface

The sheet detachment aspect of the present invention provides an apparatus and a method for facilitating the consistent removal of overlapped sheets and coating material from a transfer surface used to transport coating material into contact with a pseudo-web of overlapped sheets. The sheet detachment apparatus is particularly useful in connection with a transfer system designed to transfer an at least partially dried coating material to a pseudo-web of overlapped sheets. Briefly, such a transfer system conveys a pseudo-web of overlapped sheets to a transfer location where an endless transfer surface, moving in the same direction and at the same speed as the pseudo-web, contacts a major surface of the conveyed sheets for purposes of transferring a coating material from the transfer surface to the sheets in the pseudo-web. The coating material is remotely applied to the transfer surface by a dispensing device which is capable of applying various types of coating materials at various thickness and variable patterns to the transfer surface.

The sheet detachment apparatus includes (a) a detachment conveyor located adjacent the path of the sheets leaving the transfer location; and (b) a source of reduced pressure operable for (A) providing an area of reduced pressure over a first length of the detachment conveyor, positioned closest to the transfer location, effective for detaching sheets from the transfer surface and attracting the sheets to the detachment conveyor and, (B) providing an area of reduced pressure over a second length of the detachment conveyor effective for keeping the sheets attached to the detachment conveyor as the sheets are moved away from the transfer location.

The method comprises the ordered steps of: (i) conveying a pseudo-web of overlapped sheets along a sheet path and through a transfer location, (ii) applying a coating material to the surface of an endless transfer surface, (iii) contacting a first major surface of the sheets in the pseudo web with the coated endless transfer surface as the sheets are conveyed through the transfer location, (iv) applying a partial vacuum to that portion of the conveyor positioned immediately downstream from the transfer location effective for detaching the sheets and coating material from the transfer surface and attracting the coated sheets to the conveyor, and (v) applying a partial vacuum to the balance of the conveyor positioned downstream from the transfer location effective for keeping the coated sheets attached to the conveyor as the sheets are moved away from the transfer location.

BRIEF DESCRIPTION OF THE DRAWINGS

Figure 1 is a schematic side view of one embodiment of the invention.

Figure 2 is a schematic plan view of the apparatus shown in Figure 1.

Figure 3 is a schematic side view of a second embodiment of the invention.

Figure 4 is a schematic plan view of the apparatus shown in Figure 1.

Figure 5 is a schematic side view of a third embodiment of the invention.

5 Figure 6 is a diagrammatic illustration of the relative positions of sheets at the entry to a dual coating station forming part of the apparatus shown in Figure 1.

Figure 7 illustrates an alternative arrangement of the sheets at the entry to a dual coating station forming part of the apparatus shown in Figure 1.

10 Figure 8 is a schematic side view of a dual coating station forming part of the apparatus shown in Figure 1.

Figure 9 is an enlarged schematic side view of a portion of the dual coating station of Figure 8.

Figure 10 is an end view of a coating material supply system for the dual coating station shown in Figures 8 and 9.

15 Figure 11 is an enlarged cross-section side view of the coating drum (33) shown in Figures 8 and 9.

Figure 12 is a schematic side view of a second embodiment of a dual coating station.

20 Figure 13 is an enlarged diagrammatic side view illustrating a portion of the apparatus shown in Figure 1.

Figure 14 is an enlarged end view of the vacuum cylinder (61) shown in Figure 13.

Figure 15 is an enlarged diagrammatic side view illustrating the adhesive transfer station shown in Figure 1.

25 Figure 16 is an enlarged side view illustrating a portion of the adhesive transfer station shown in Figure 15.

Figure 17 is an enlarged partial plan view of the vacuum box (94) shown in Figure 16.

Figure 18 is an enlarged partial plan view of the vacuum belt (95) shown in Figure 16.

30 Figure 19 is a diagrammatic plan view of an alternative sheet arrangement useful in operation of the apparatuses shown in Figures 1, 3 and 5.

Figure 20 is an enlarged side view of the sheet feeder station shown in Figure 5.

Figure 21 is a diagrammatic side view of a portion of a second embodiment of an adhesive transfer station.

Figure 22 is an enlarged partial view in the direction of the arrow 4 in Figure 21.

Figure 23 is a side view of the coating roller and smoothing stripe of Figure 22.

Figure 24 is a greatly magnified view of the gravure rings (77r) shown in Figure 22.

5 Figure 25 is a schematic and diagrammatic side view of a third embodiment of an adhesive transfer system.

Figure 26 is an enlarged partial view in the direction of the arrow 8 in Figure 25.

Figure 27 is a cross-sectional side view of one embodiment of the transfer belt shown in Figures 21 and 25.

10 Figure 28 is a photomicrograph illustrating a repositionable adhesive which has been manually applied to the transfer belt of the apparatus as shown in Figures 21 and 25.

DETAILED DESCRIPTION OF THE INVENTION INCLUDING A BEST MODE

15 Nomenclature

	1	Sheet Feeding Station
	2	Sheet Inserting Station
	2a	Insert Conveyor
	2b	Insert Sheet Feeder
20	3	Dual Coating Station
	4	Sheet Spacing Station
	5	Drying Station
	6	Sheet Guiding Station
	7	Adhesive Transfer Station
25	8	Sheet Overlapping Station
	9	Sheet Stacking Station
	10	Table
	11	Stack of Sheets
	12	Suction Head
30	12a	Jet Nozzle
	13	Paired Feed Rollers
	14	First Conveyor
	15	Stop Gate
	16	Upper Coating System
35	17	Lower Coating System
	20	Insert Sheet
	21	Missing Sheet
	22	Preceding Sheet
	23	Succeeding Sheet
40	25a	Gear Box
	25b	Two-Way Clutch
	30	Nip Roll Pair
	31	Upper Metering Roller
	31t	Upper Primer Trough

	32	Upper Coating Roller
	32c	Upper Counter Roller
	33	Coating Drum
	34	Lower Metering Roller
5	34t	Lower LAB Trough
	35	Lower Coating Roller
	35c	Lower Counter Roller
	36	Channel in Coating Drum
	37	Sheet Gripper
10	38	Pad
	38a	Support Sheet
	40	Upper Nozzles
	41	Primer Supply Tank
	42	Pump
15	43	Overflow Outlets
	45	Lower Nozzles
	46	LAB Supply Tank
	47	Pump
	48	Overflow Outlets
20	50	Clasping Unit
	51	Second Conveyor
	52	Clasp
	53	Endless Chain
	54	Blower
25	55	Low Pressure Source
	56	Third Conveyor
	60	Air Knife
	61	Vacuum Cylinder
	62	Ends of Vacuum Cylinder
30	63	Apertures Through Vacuum Cylinder
	66	Vacuum Pump
	67	Line Between Vacuum Cylinder and Vacuum Pump
	68	Deflection Plate
	70	Transfer Location
35	71	Transfer Belt
	72	Tension Rollers
	73	Direction of Transfer Belt Movement
	74	Coating System
	75	Adhesive Dryer
40	76	Transfer Surface
	77	Gravure Roller
	77r	Gravure Rings
	78	Pump
	79	Adhesive Supply Tank
45	80	Adhesive Trough
	81	Metering Roller
	82	Doctor Blades
	84	Exhaust Fan
	85	Transfer Nip
50	86	Overlapped Sheets Passing Through the Adhesive Transfer Location
	90	Drive Roller
	91	Idler Counter-Pressure Roller

	92	Grooves in Drive Roller
	93	Fingers
	94	Vacuum Box
	94a	Forward Chamber of Vacuum Box
5	94b	Rear Chamber of Vacuum Box
	94x	Openings in Forward Chamber
	94y	Openings in Rear Chamber
	95	Vacuum Belt
	96	Standard Conveyor
10	97	Additional Roller
	97p	Pivot Line of Additional Roller
	98	Apertures in the Vacuum Belt
	99	Sheet Margin
	100	Machine Direction
15	110	Input Rollers
	111	Drive Rollers
	112	Lever
	113	Output Rollers
	121	First Portion of a Split Apparatus
20	122	Second Portion of a Split Apparatus
	130	Stack of Dual Coated and Dried Sheets
	140	Stack of Adhesive Coated Sheets
	150	Secondary Sheet Inserter
	220a	Base Layer of Transfer Belt
25	220b	Front Major Surface of Base Layer
	220c	Back Major Surface of Base Layer
	220d	Front Release Layer
	220e	Back Release Layer
	220g	Indentations in Base Layer
30	220h	Outermost Surface of Front Release Layer
	220i	Outermost Surface of Back Release Layer
	220j	Indentations in Release Layers
	229	Smoothing Strips
	230	Cells in Gravure Rings
35	230A	Pattern Line of Cells in Gravure Rings
	236	Adhesive Stripes
	239	Vacuum Roller
	242	Coating Die
	245	Adhesive Supply Line
40	246	Pump
	247	Filter

Definitions

As utilized herein, including the claims, the term "vacuum" means any pressure
 45 which is less than atmospheric and possessing sufficient attractive force to achieve the
 desired removal or retention of sheet members.

Construction

THE APPARATUS

The apparatus (unnumbered) is specifically designed for use in the production of repositionable notes (not shown) from sheets (unnumbered) of any suitable substrate material, for example, paper, polymeric film or foils, such as metallic foils and, in particular, for the application to individual sheets (unnumbered) of a primer material (not shown), a low adhesion backsize (LAB) material (not shown), and a repositionable adhesive (not shown) so that the sheets can subsequently be used to form repositionable notes. In the following description, it will be assumed, unless otherwise noted, that the sheets (which may be pre-printed) are of paper. The paper may be any suitable paper, such as the paper utilized to construct the Post-It® brand repositionable notes available from Minnesota Mining and Manufacturing Company ("3M") of St. Paul, Minnesota. When the sheets are formed of paper, the sheets are preferably transported through the apparatus with the machine direction (unnumbered) of the paper sheets running parallel to the machine direction **100** of the apparatus in order to reduce the tendency of the paper sheets to curl or wrinkle while being processed.

THE FIRST EMBODIMENT

As shown in Figures 1 and 2, a first embodiment of the apparatus includes a sheet feeding station **1** which delivers a succession of paper sheets (not shown) from a stack of sheets **11** onto a first conveyor **14** so as to initiate movement of paper sheets along a sheet path (unnumbered). From the sheet feeder **1**, the sheets travel along the sheet path in a machine direction indicated by the arrow **100**. The succession of sheets then sequentially travel (i) past a sheet inserting station **2** located to one side of the sheet path, (ii) through a dual coating station **3**, (iii) through a sheet spacing station **4**, (iv) through a drying station **5**, (v) through a sheet guiding station **6**, and (vi) an adhesive transfer station **7**. Control and synchronization of sheet movement through the various stations (1 through 7) may be performed by a central electronic control unit (not shown), for example a Siemens PLC 135.

As described in greater detail below, when the sheet inserting station **2** is not in use, sheets leave the sheet feeding station **1** in a continuous stream in which, to reduce the space required between the sheet feeding station **1** and the dual coating station **3**, the trailing edge (unnumbered) of each preceding sheet **22** overlapping the leading edge (unnumbered) of the succeeding sheet **23**. The sheets are, however, conveyed separately through the dual coating station **3** where they are coated individually on one major surface

(unnumbered) with a primer material ,and on the other major surface (unnumbered) with a low adhesion backsize material. The sheets emerging from the dual coating station 3 are then overlapped once again, in the sheet spacing station 4, so as to form a pseudo-web (unnumbered) in which the trailing edge of each sheet is overlapped by the leading edge of the succeeding sheet 23. The pseudo-web is then maintained throughout the remainder of the apparatus although the initial direction of overlap, being unsatisfactory for the drying station 5 and unsuitable for the adhesive transfer station 7, is reversed when the pseudo-web leaves the sheet spacing station 4. Following passage through the drying station 5 (in which the primer and LAB coatings are dried), the pseudo-web passes through the sheet guiding station 6 where the sheets are side registered and aligned, and through the adhesive transfer station 7 where a plurality of adhesive stripes 236 are applied to the major surface of the sheets coated with primer. The sheets can then be stacked and trimmed as required to form pads of repositionable notes.

THE SECOND EMBODIMENT

As shown in Figures 3 and 4, a second embodiment of the apparatus duplicates the first embodiment until the sheets reach the dual coating station 3. In the second embodiment, once the sheets travel through the dual coating station 3, the sheets are conveyed through (i) a sheet spacing station 4, (ii) a drying station 5, (iii) a sheet overlapping station 8, and finally (iv) an adhesive transfer station 7. This slightly reconfigured apparatus permits the sheets to be conveyed through both the dual coating station 3 and the drying station 5 before the sheets are overlapped.

THE THIRD EMBODIMENT

As shown diagrammatically in Figure 5, a third embodiment of the apparatus duplicates the first or second embodiments, but splits the process and the apparatus into two independent and distinct portions. The first portion 121 includes the sheet feeding station 1, sheeting inserting station 2, dual coating station 3, sheet spacing station 4, and sheet drying station 5 described in connection with the first and second embodiments. The first portion 121 terminates with a sheet stacking station 9 where stacks 130 of dual coated and dried sheets are collected. The second portion 122 commences with a duplicate of the sheet feeding station 1 into which a stack 130 of the dual coated and dried sheets has been inserted. The second portion then includes the sheet overlapping station 8 and adhesive transfer station 7 described in connection with the first and second embodiments. Finally,

the second portion, like the first portion, terminates with a sheet stacking station 9 for stacking the adhesive coated sheets.

This split system permits each part of the process to be conducted independently of the other. Hence, sheets can be coated with primer and LAB at one time and/or place, and the adhesive coated onto the sheets at a different time and/or place.

Alternatively, the second portion of the process can utilize dual coated sheets which have been produced by a completely different process, such as sheets produced by the conventional roll-to-roll process which coats primer and LAB onto a continuous roll of a substrate which is subsequently cut into sheets.

10

THE SHEET FEEDING STATION

While a variety of suitable sheet feeding stations are commercially available, a suitable sheet feeding station 1 is shown in Figure 1. The sheet feeding station 1 shown in Figure 1 is a rear edge feeder comprising a vertically movable table 10 on which a stack of sheets 11 is located. A suction head 12 is positioned above the rear edge (unnumbered) of the stack 11 for lifting the top sheet (unnumbered) from the stack 11 by its rear edge and moving the sheet forward. Forward movement of the lifted sheet is assisted by a jet of air from jet nozzle 12a. The lifted sheet is then taken up by paired feed rollers 13 and conveyed out of the sheet feeding station 1 and onto a first conveyor 14. The suction head 12 returns to its original position and picks up the next sheet and repeats the process while the first sheet is still present between the paired feed rollers 13. In that way, the trailing edge (not shown) of each preceding sheet 22 overlaps the leading end (not shown) of the succeeding sheet 23 as the sheets pass between the paired feed rollers 13 and are fed onto the first conveyor 14. The length of the overlap depends on the length of the sheets and the relationship between the operation of the suction head 12 and the take-up speed of the paired feed rollers 13. In order to avoid the need for an unnecessarily long gap between the sheet feeding station 1 and the dual coating station 3, the length of the overlapping portions of each sheet is preferably quite large. For example, an overlap of about 70% of the length of each sheet may be satisfactorily used.

As the height of the stack 11 decreases, the table 10 moves upwards to maintain the top (unnumbered) of the stack 11 in a predetermined vertical location relative to the suction head 12. The sheets in each stack 11 are preferably all of the same size and weight.

30

Sheet feeders of the type just described are available from a variety of sources including MABEG Maschinenbau GmbH of Offenbach, Germany, under the trade designation "41988".

5 THE FIRST CONVEYOR AND STOP GATE

Sheets exiting the sheet feeding station 1 are deposited on the first conveyor 14 and transported past the sheet inserting station 2 to a stop gate 15 at the entry (unnumbered) to the dual coating station 3. When the sheet inserting station 2 is not operating, the overlapped sheets deposited onto the first conveyor 14 by the sheet feeding station 1 form a continuous succession of overlapped sheets on the first conveyor 14. As
10 each sheet arrives at the stop gate 15, its forward progress is temporarily halted while the coating drum 33 rotates to the correct position for transporting and coating the sheet. The stop gate 15 then opens to allow a single accumulated sheet to enter the dual coating station 3. The stop gate 15 then closes in advance of the arrival of a succeeding sheet 23
15 so as to temporarily halt the forward progress of that sheet until the coating drum 33 has once again rotated to the correct position.

THE SHEET INSERTING STATION

The sheet inserting station 2 is used to insert one or more sheets from a second
20 stack of sheets (not shown) into the succession of sheets entering the dual coating station 3. To avoid disrupting the pseudo-web of sheets which is formed in the sheet spacing station 4, it is important that the inserted sheet(s) be accurately placed in the succession of sheets supplied to the dual coating station 3.

The sheet inserting station 2 includes a rear edge insert sheet feeder 2b which is
25 generally similar to the rear edge sheet feeder described in connection with the sheet feeding station 1. The sheet inserting station 2 is located to the side of the sheet path and positioned between the sheet feeding station 1 and the stop gate 15. The sheet inserting station 2 is provided with an insert conveyor 2a which feeds insert sheets 20 directly into the sheet path upstream from the stop gate 15. The insert sheets 20 can be constructed
30 from any suitable type of material, but will normally differ in some manner from the sheets dispensed by the sheet feeding station 1. Between each periodic insertion of an insert sheet 20, the sheet inserting station 2 holds several overlapped sheets on the insert conveyor 2a which are ready to be quickly inserted into the sheet path. When an insert sheet 20 is to be inserted into the succession of sheets being transported along the sheet

path, operation of the sheet feeding station 1 is inhibited for one cycle so that a sheet will be missing from the succession of sheets fed by the sheet feeding station 1 onto the first conveyor 14 at a predetermined location. The insert conveyor 2a is actuated at the appropriate time to insert an input sheet into the sheet path to replace the missing sheet 21.

5 If required, more than one insert sheet 20 can be inserted in succession, in which case it would be necessary to inhibit operation of the sheet feeding station 1 for a corresponding number of cycles.

Figure 6 illustrates an insert sheet 20 in the process of being delivered to the stop gate 15. The position that the missing sheet 21 would have occupied in the succession of sheets exiting the sheet feeding station 1 is indicated by the dashed line 21. Sheet 22
10 represents the sheet immediately preceding the missing sheet 21. As soon as the stop gate 15 opens and allows preceding sheet 22 to enter the dual coating station 3, the insert sheet 20 is deposited immediately upstream from the stop gate 15 in the place of missing sheet 21. Because the insert sheet 20 is inserted from above the sheet path, the trailing edge
15 (unnumbered) of the insert sheet 20 will overlap the leading edge (unnumbered) of the succeeding sheet 23, as though the insert sheet 20 had been supplied from the sheet feeding station 1.

For paper sheets of certain sizes, the sheet insertion procedure described above can only be carried out successfully by changing the speed at which the sheets travel from the sheet feeding station 1 to the dual coating station 3. Referring to Figure 6, it is noted that,
20 although forward progress of the preceding sheet 22 has been halted at the stop gate 15, the succeeding sheet 23 continues to be carried forward towards the stop gate 15 by the first conveyor 14. The length of the gap (unnumbered) between the preceding sheet 22 and the succeeding sheet 23 is dependent on the length of the sheets 22 and 23. In some cases, the
25 lengths of the sheets 22 and 23 will result in an open gap between these sheets until forward progress of the preceding sheet 22 is halted by the stop gate 15. The continued forward progress of the succeeding sheet 23 causes the leading edge of the succeeding sheet 23 to contact the trailing edge of the preceding sheet 22 while the preceding sheet 22 is still waiting at the stop gate 15. This situation is undesirable because it can cause the
30 sheets to buckle and jam. The situation can be avoided by reducing the speed of the first conveyor 14 as necessary to ensure that the leading edge of the succeeding sheet 23 does not contact the trailing edge of the preceding sheet 22 when an open gap is created by skipping a sheet in order to accommodate an insert sheet 20. The particular sizes of paper for which such a reduction in speed will be required depends upon the normal speed of the

first conveyor **14** and the length of time for which sheets are held at the stop gate **15**. It may, for example, be found that A4 size sheets can be handled without any problems because the length of the gap caused by skipping a sheet is always so long that the leading edge of succeeding sheet **23** never contacts the trailing edge of the preceding sheet **22**. It may also be found that A2 size sheets can be handled without any problems because, even when a sheet has been skipped, the trailing edge of the preceding sheet **22** always overlaps the leading edge of the succeeding sheet **23**. This later situation is illustrated in Figure 7, wherein the position that the missing sheet **21** would have occupied is indicated by the dashed line **21**. It may, however, then be found that sheets with a length somewhere between the lengths of A4 and A2 size sheets (210 mm and 420 mm respectively) require that the speed of the first conveyor **14** be reduced. Such a speed reduction (which is necessary only when there is both a gap in the succession of sheets and the sheets will contact one another when forward progress of the preceding sheet **22** is halted at the stop gate **15**) can be effected by a central electronic control unit (not shown) through a gear box **25a** and a two-way clutch **25b** in communication with the main drive (not shown) of the sheet feeding station **1**, as indicated diagrammatically in Figure 2.

THE DUAL COATING STATION

As shown in Figure 1, and in greater detail in Figures 8 and 9, sheets fed through the stop gate **15** enter the dual coating station **3** and are picked up by a nip roll pair **30**. The nip roll pair **30** feeds the sheet between the upper coating system **16** and lower coating system **17** which are located above and below the sheet path respectively. The upper coating system **16** applies a coating of primer (not shown) to the upper major surface (not shown) of each sheet and the lower coating system **17** simultaneously applies a coating of LAB (Not shown) to the lower major surface (not shown) of each sheet.

It is one of the advantages of the present apparatus, as compared to other arrangements such as in the above identified WO94/19419 reference, that the sheets are fed individually through the dual coating station **3** without any overlap. This permits substantially the entire surface area of both major surfaces on each sheet to be coated with primer and LAB.

Paper is commonly formed by accumulating paper fibers (not shown) on a wire mesh or screen (not shown) and compressing the accumulated fibers between the screen and a "felt" or cloth layer (not shown) opposite the screen layer. This produces paper

having a "wire" side and a "felt" side. It has also been found advantageous to convey the sheets through the apparatus of the present invention with the "wire" side presented for coating of the release material (not shown) and the "felt" side presented for coating of the primer (not shown) and ultimately for coating of the adhesive (not shown).

5 Each sheet is simultaneously coated with primer and LAB. The primer and LAB are preferably selected and applied at a similar viscosity, wt% solids, coating weight, etc., so as to minimize the potential for wrinkling or curling of the sheets to which the coatings have been applied.

10 The coating achieved in the dual coating station 3 is discontinuous since it occurs only when the pad 38 on the coating drum 33 abuts upper coating roller 32 and a sheet has been fed through the nip roll pair 30 and onto the pad 38.

The Coating Drum

15 Referring to Figure 11, the coating drum 33 includes a rectangular lateral channel 36 which contains a conventional sheet gripper 37 for grasping sheets fed from the nip roll pair 30. That portion of each sheet engaged with the sheet gripper 37 will not be available for coating with primer or LAB.

The surface (unnumbered) of the coating drum 33 is covered, around less than half its circumference, with a pad 38.

20

The Upper Coating System

25 The upper coating system 16 includes an upper metering roller 31 and an upper coating roller 32 located above the sheet path. The upper coating roller 32 cooperates with the coating drum 33 to form a coating nip (unnumbered). The coating drum 33 and the upper coating roller 32 are positioned relative to one another such that the upper coating roller 32 forms a coating nip with the coating drum 33 only when the pad 38 is adjacent the upper coating roller 32.

30 An upper trough 31t for holding a supply of primer is formed by the surfaces of the upper metering roller 31 and upper coating roller 32 and a pair of opposed end walls (not shown) which are sealably engaged within grooves (not shown) in the ends (unnumbered) of the rollers 31 and 32. As the rollers 31 and 32 are rotated, primer material in the upper trough 31t forms a film on the upper coating roller 32 for transference to a sheet passing underneath the upper coating roller 32 on the pad 38 of the coating drum 33.

The thickness of the primer film (not shown) on the upper coating roller 32, and hence the amount of primer coated onto a sheet, is dependent upon the viscosity of the primer and the contact pressure between the upper metering roller 31 and the upper coating roller 32. For a given primer, the thickness of the primer coated onto a sheet can be adjusted by moving the upper metering roller 31 relative to the upper coating roller 32 and by adjusting the rotational speed of the upper metering roller 31.

Referring to Figure 10, the upper trough 31t is supplied with primer by laterally spaced upper nozzles 40 which receive primer from a supply tank 41 by means of a pump 42. The upper trough 31t also has overflow outlets 43 through which excess primer is returned to the primer supply tank 41.

The Lower Coating System

The lower coating system 17 is essentially a mirror image of the upper coating system 16 positioned below the sheet path. The lower coating system 17 includes a lower metering roller 34 and an lower coating roller 35 located above the sheet path. The lower coating roller 35 cooperates with the coating drum 33 to form a coating nip (unnumbered). The coating drum 33 and the lower coating roller 35 are positioned relative to one another such that the lower coating roller 35 forms a coating nip with the coating drum 33 only when the pad 38 is adjacent the lower coating roller 35.

A lower trough 34t for holding a supply of LAB is formed by the surfaces of the lower metering roller 34 and lower coating roller 35 and a pair of opposed end walls (not shown) which are sealably engaged within grooves (not shown) in the ends (unnumbered) of the rollers 34 and 35. As the rollers 34 and 35 are rotated, LAB material in the lower trough 34t forms a film on the lower coating roller 35 for transference to a sheet passing over the lower coating roller 35 on the pad 38 of the coating drum 33.

The thickness of the LAB film (not shown) on the lower coating roller 35, and hence the amount of LAB coated onto a sheet, is dependent upon the viscosity of the LAB and the contact pressure between the lower metering roller 34 and the lower coating roller 35. For a given LAB, the thickness of the LAB coated onto a sheet can be adjusted by moving the lower metering roller 34 relative to the lower coating roller 35 and by adjusting the rotational speed of the metering roller 34.

Referring to Figure 10, the lower trough 34t is supplied with LAB by laterally spaced lower nozzles 45 which receive LAB from a supply tank 46 by means of a pump

47. The lower trough **34t** also has overflow outlets **48** through which excess LAB is returned to the LAB supply tank **46**.

The sheets may optionally be pre-printed with indicia. In order for the indicia to be presented on the front surface of the padded notes (not shown) the indicia must be printed on the major surface of the sheets which is coated with the LAB. Hence, when pre-printed sheets are coated in the dual coating station **3**, the printed indicia will be covered with the LAB applied to the sheet by the lower coating system **17**. In this way, the LAB serves to protect the printed matter, especially from being removed by the adhesive coated onto the immediately preceding note in the stack. Such protection offered by the LAB coating enables the use of stronger adhesives on pads of pre-printed notes. Of course, printed indicia may also be applied to the sheets after the sheets exit the dual coating station **3** using conventional printing techniques.

Sheet Strippers

Sheet strippers (not shown) are located on the downstream side of both the upper **32** and lower **35** coating rollers as well as the coating drum **33** to ensure that sheets do not wrap around the rollers **32**, **35** or the drum **33**, but exit the dual coating station **3** and proceed towards the sheet spacing station **4**.

Alternatively, as shown in Figure **12**, the dual coating station **3** could apply the primer and LAB coatings sequentially rather than simultaneously. For example, the coating drum **33** is removed and the upper coating system **16** located upstream from the lower coating system **17**. Each of the upper coating roller **32** and the lower coating roller **35** are provided with a counter-pressure roller **32c** and **35c**, respectively. However, such an alternative method does not provide the benefits associated with the simultaneous coating procedure described herein. It is noted that the alternative embodiment shown in Figure **12** also depicts supply troughs **31t** and **34t**, for supplying primer and LAB materials to the upper **31** and lower **34** metering rollers, respectively.

Pad and Support Sheet

The pad **38** on the coating drum **33** can be constructed from any suitable type of material. Preferred materials are the various elastomeric materials such as the natural and synthetic rubbers. The pad **38** is secured by an adhesive (not shown) to a support sheet **38a** which is wrapped around and releasably secured to the coating drum **33**. Suitable materials for use as the support sheet **38a** include the various flexible plastics such as Mylar™. The pad **38** may be secured to the support sheet **38a** by a neoprene glue such as

that available under the trade designation 1236™ from Minnesota Mining and Manufacturing Company of St. Paul, Minnesota, U.S.A. The support sheet 38a preferably extends around the full circumference of the coating drum 33 with the ends (unnumbered) of the support sheet 38a extending down into the channel 36 formed in the coating drum 33. The support sheet 38a may be releasably secured to the coating drum 33 by any convenient means such as bolts or machine screws (not shown). In that way, the pad 38, which is a wearable item, is securely attached to the coating drum 33, but can be easily removed from the coating drum 33 and replaced when necessary.

Should the pad 38 be adhered to the support sheet 38a while the support sheet 38a is laid-out flat, it is preferred that a flexible adhesive be used to secure the pad 38 to the support sheet 38a. Obviously, the flexibility of the adhesive is less important when the pad 38 is secured to the support sheet 38a only after the support sheet 38a has been conformed to the shape of the coating drum 33. Any suitable adhesive can be used to secure the pad 38 to the support sheet 38a provided the adhesive is sufficiently aggressive to prevent the corners of the pad 38 from lifting away from the support sheet 38a throughout the lifespan of the pad 38.

The pad 38 may be constructed from Cyrell™, a polyurethane material available from E.I. DuPont de Nemours of Wilmington, Delaware, U.S.A.

20 Primer

The primer may, by way of example, be an aqueous solution of an organic binding agent and a cleaved mineral pigment. More specifically, the primer material may be obtained by mixing approximately 3 to 7 wt% of the binding agent MOWIOL™ available from Hoechst AG of Frankfurt/Main, Germany, and approximately 3 to 8 wt% of the pigment AEROSIL™ available from Degussa AG, Frankfurt/Main, Germany, in water.

A typical coating weight for the primer on the sheets is from about 0.5 gsm to about 12.0 gsm. The coating weights of the primer and the LAB are preferably matched so that both major surfaces of each sheet dry at approximately the same rate and thereby reduce the wrinkling and curling commonly associated with the drying of wet sheets.

30 Low Adhesion Backsize (LAB)

The LAB may be selected from any of a variety of suitable materials including, but not limited to, acrylate copolymers, silicones, urethanes, and fluoro polymers. For example, the LAB may be selected from the aqueous LAB solutions described in EP-A-

0618509. Other LAB materials that may be employed include those disclosed in United States Patent Nos. 5,202,190 and 5,032,460.

A typical coating weight for the LAB on the sheets is from about 0.5 gsm to about 12.0 gsm. Again, the coating weights of the primer and the LAB are preferably matched so that both major surfaces of each sheet dry at approximately the same rate and thereby reduce the wrinkling and curling commonly associated with the drying of wet sheets.

THE SHEET SPACING STATION

As shown in Figure 1, and in greater detail in Figures 8 and 9, sheets exiting the dual coating station 3 enter a sheet spacing station 4 in which a clasping unit 50 is positioned to grab the dual coated sheets as they emerge from the coating nip, and deposit them on a second conveyor 51 shown in Figure 8. The clasping unit 50 is a conventional unit which includes clasps 52 carried on an endless chain 53. Movement of the chain 53 is synchronized with rotation of the coating drum 33 so that a clasp 52 is positioned to receive each dual coated sheet as the sheet leaves the coating nip.

With reference to Figure 8, a blower 54 is positioned below the sheet path, proximate the exit side of the coating nip, for providing a cushion of air to support the sheets as they are carried by the clasps 52 towards the second conveyor 51. The blower 54 incorporates a heater (not shown) which serves to partially dry the LAB coating on the underside of the sheet before the sheet is deposited upon the second conveyor 51. This reduces the tendency of the dual coated sheets to stick to the second conveyor 51.

The second conveyor 51 is run at a slower speed than the chain 53 of the clasping unit 50. This causes a leading edge portion of each sheet which is deposited on the second conveyor 51 to overlap a trailing edge portion of the preceding sheet 22 and form a pseudo-web of overlapped sheets. Typically, but not essentially, the extent of the overlap is from about 1 to 2 cm.

Alternatively, the second conveyor 51 can be run at essentially the same speed as the chain 53 of the clasping unit 50. This maintains a gap between the sheets deposited on the second conveyor 51. Such an arrangement of the sheets allows the sheets to be dried individually within the drying station 5 and thereby avoid those issues resulting from the drying of partially overlapped sheets.

The second conveyor 51 is preferably a vacuum conveyor which is connected to a source of low pressure 55. The suction created by the low pressure source 55 holds the

sheets in position on the second conveyor **51** for maintaining the necessary overlapped relationship between the sheets.

A single unit which combines a dual coating station **3** and a sheet spacing station **4** is commercially available from Billhöfer Maschinenfabrik GmbH of Nürnberg, Germany
5 under the designation Gulla Speed GS GS 8000™.

OVERLAP REVERSING SYSTEM

As shown in Figure 13, the sheets on the second conveyor **51** are transferred to a third conveyor **56** for transportation through a drying station **5**. A system (unnumbered)
10 for reversing the overlapped position of the sheets when they have been overlapped by the sheet spacing station **4** is provided between the second **51** and third **56** conveyors. The system includes (i) an air knife **60** positioned below the sheet path and between the second **51** and third **56** conveyors for lifting the overlapped edge portions of the sheets as they pass over the air knife **60**, and (ii) a stationary vacuum cylinder **61** positioned above the
15 sheet path and slightly downstream from the air knife **60** for attracting and temporarily delaying return of the lifted trailing edge portion of the sheets. The system thereby causes the leading edge portion of each sheet to return to the paper path before the trailing edge portion of the preceding sheet **22** returns so as to reverse the overlapped relationship between each set of overlapped sheets.

20 The vacuum cylinder **61** has closed ends **62** and a plurality of apertures **63** through that portion of the vacuum cylinder surface (unnumbered) directed towards the air knife **60**. The remainder of the vacuum cylinder **61** is closed. The apertures **63** are connected to the hollow interior (not shown) of the vacuum cylinder **61**, and the hollow interior connected by a line **67** to a vacuum pump **66**.

25 The vacuum cylinder **61** can conveniently have a diameter of about 15 cm with three rows of apertures **63** spaced 30 mm apart. The apertures **63** can conveniently have a diameter of 6 mm with the individual apertures **63** in each row spaced 30 mm apart.

Since the suction exerted by the vacuum cylinder **61** does not influence the sheets while they are within the sheet plane, the vacuum can be applied constantly. The vacuum
30 should be applied at a level sufficient to ensure that it attracts and retains the trailing edge of the sheets lifted by the air knife **60** without interfering with continued forward movement of the sheet on the third conveyor **56**.

Optionally, a deflection plate 68 can be positioned above the vacuum cylinder 61 and the air knife 60, such as shown in Figure 13, to direct the air jet emanating from the air knife 60 towards the vacuum cylinder 61.

Other systems can also be used to reverse the overlap of a succession of overlapped sheets such as an air knife 60 alone or a mechanical arrangement similar to that described in GB-A-2 166 717. However, such systems would not provide the efficiency and reliability associated with the system described herein.

DRYING STATION

Returning to Figure 1, the pseudo-web of overlapped sheets is transported by the third conveyor 56 from the sheet spacing station 4 and through a drying station 5 where moisture is removed from the primer and LAB coatings on the sheets. The overlapped sheets are moved continuously through the drying station 5 by the third conveyor 56 and are dried at a rate which attenuates the tendency of the sheets to curl without unduly slowing the line speed or requiring an overly large drying station 5.

The drying station 5 preferably uses a radio-frequency dryer to dry the primer and LAB coatings. A suitable dryer is a Model No. SP 890 GF "C"-AG manufactured by Proctor Strayfield Ltd. of Berkshire, England which has been adapted to fit this specific system. The use of a radio-frequency dryer is preferred but not essential. The overlapped sheets could, instead, be dried using infra-red or forced air heating systems. Alternatively, the third conveyor 56 could be heated. However, a radio-frequency dryer is preferred for a number of reasons, including its simplicity, lower energy consumption, reduced thermal build-up, etc.

The drying station 5 is provided with a control unit (not shown) for automatically adjusting the power of the dryer in accordance with the line speed of the system. A suitable control unit is available from Siemens under the designation PLC 55 95U. The control unit can be interconnected with the central electronic control unit (not shown) for the entire system, for purposes of sending and receiving the information necessary to properly monitor and control operation of the system.

Although it is preferable to reverse the direction of overlap before the sheets enter the drying station 5 in order to reduce the likelihood that the sheets will be lifted from the third conveyor 56, it is possible to reverse the direction of the overlap after the sheets have been dried by positioning the sheet spacing station 4 downstream from the drying station 5 as shown in Figure 3.

SHEET GUIDING STATION

As shown in Figure 1, the dried coated sheets are transferred from the third conveyor 56 to a sheet guiding station 6 in which the sheets are side registered and aligned with each other in preparation for advancement through the adhesive transfer station 7.

SHEET OVERLAPPING STATION

As shown in Figure 3, when the sheets are fed individually through the drying station 5, a sheet overlapping station 8 is positioned between the drying station 5 and the adhesive transfer station 7 for overlapping the sheets before they enter the adhesive transfer station 7.

The sheet overlapping station 8 comprises a pair of input rollers 110 which take up sheets exiting the drying station 5 and pass the sheets between a pair of drive rollers 111. The drive rollers 111 transport the sheets to a lever 112. The lever 112 pivots between a first position, as shown in Fig. 3, where the lever 112 projects into the sheets path and stops the forward progress of any sheets which contact the lever 112, and a second position where the lever 112 is positioned below the sheet path and any accumulated sheets are allowed to proceed forward towards the adhesive transfer station 7.

The drive rollers 111 are pivotable between an open position and a closed position in response to the position of the lever 112. The drive rollers 111 are opened when the lever 112 is pivoted into the first position so that a sheet emerging from the input rollers 110 will pass freely between the drive rollers 111 and be temporarily halted at the lever 112. When the lever 112 is pivoted into the second position below the sheet path, the drive rollers 111 are closed and form a nip which propels the sheet resting on the drive rollers 111 towards output rollers 113. Once the sheet has been taken up by the output rollers 113, the lever 112 is returned to the first position and the drive rollers 111 opened to allow a succeeding sheet 23 from the input rollers 110 to pass through to the lever 112 until the succeeding sheet 23 strikes the lever 112.

As shown in Figure 3, the lever 112 is returned to the first position while a portion of the preceding sheet 22 is still positioned over the lever 112 so that a trailing portion of the preceding sheet 22 is lifted up from the sheet path by the lever 112. The lever 112 is then pivoted to the second position and the drive rollers 111 closed while a trailing edge portion of the preceding sheet 22 is still above the lever 112 so that the trailing edge portion of the preceding sheet 22 will overlap a leading edge portion of the succeeding

sheet 23. Typically, an overlap of between about 1 to 2 cm is sufficient to ensure that a complete pseudo-web of overlapped sheets will be transported to the adhesive transfer station 7.

It will be appreciated that the particular sheet overlapping station 8 described herein to produce the pseudo-web of sheets is not an essential feature of the overall system, and that any other mechanism capable of producing the same overlapping arrangement of sheets could be employed.

ADHESIVE TRANSFER STATION

The registered overlapped sheets pass through a transfer location 70 where they contact an endless transfer belt 71 to which an adhesive coating (not shown) has previously been applied in the form of a plurality of stripes 236 extending longitudinally along the transfer belt 71.

Transfer Belt

The transfer belt 71 is trained around a series of tension rollers 72, at least one of which is driven so that the transfer belt 71 advances in the direction of the arrow 73 and in the machine direction 100 through the transfer location 70. The transfer belt 71 is advanced at the same speed as the overlapped sheets and passes (i) a coating system 74, (ii) an adhesive dryer 75, and (iii) the transfer location 70.

The transfer belt 71 may be constructed from a variety of materials including various silicone rubber coated metals and plastics. The transfer belt 71 is preferably constructed from a radio frequency transparent material so that a radio frequency adhesive dryer 75 may be used. As utilized herein, the term "radio frequency transparent" means that the material does not appreciably interact with radio frequency radiation such that the radiation passes through the material without generating appreciable heat or volatilizing the material. A suitable radio frequency transparent transfer belt 71 comprises an approximately 0.1 mm thick fiberglass fabric base layer 22a coated on both major surfaces with an approximately 0.15 mm thick silicone rubber skin.

One embodiment of the transfer belt 71 is shown in cross-section in Figure 27. In this embodiment, the transfer belt 71 includes a base layer 220a comprising a 0.004 inch thick fiberglass fabric belt which is commercially available from J.P. Steven, of North Carolina. The base layer 220a is coated on both the front 220b and back 220c major surfaces with a 0.003 inch thick release layer 220d and 220e respectively. The outermost

surfaces **220h** and **220i** of the release layers **220d** and **220e** form the surface which receives adhesive from the gravure roller 77 and transfers the adhesive to the overlapped sheets at the transfer location 70. The combination of base layer **220a** and release layers **220d** and **220e** results in a transfer belt 71 having a total thickness of approximately 0.010
5 inches. A suitable material for use in forming the release layers **220d** and **220e** is a dispersion of a silicone rubber solution available from the Silicone Products Division of General Electric Co. of Waterford, New York under the designation G.E. SE-100. The solution contains 6 wt% solids with a 78% benzoyl peroxide solution in water as a catalyst.

The release layers **220d** and **220e** can be formed by knife coating the desired
10 material onto the base layer **220a** and oven dried at 360°F at a rate of 60 yards/hour. The release layers **220d** and **220e** facilitate the release of adhesive from the transfer belt 71 onto the overlapped sheets at the transfer location 70.

The outermost surfaces **220h** and **220i** of the release layers **220d** and **220e** may be smooth or textured, but are preferably textured or convoluted for purposes of further
15 facilitating the release of adhesive from the transfer belt 71 onto the overlapped sheets. Most preferably, the outer surfaces **220h** and **220i** are textured with a pattern of indentations that impose a complementary pattern in the adhesive stripes **236** transferred from the transfer belt 71 to the overlapped sheets of paper at the transfer location 70.

A preferred indentation pattern is shown in Figure 28. The pattern generally
20 comprises an array of indentations **220j** which are formed from corresponding indentations **220g** in base layer **220a**. The indentations **220g** in the base layer **220a** may be formed during the process of weaving the fiberglass layer. Alternatively, the pattern of indentations **220g** in the base layer **220a** may be embossed or otherwise imposed on the outermost surfaces **220h** and **220i** of the release layers **220d** and **220e**.

The indentations **220j** on the outermost surface of the release layers **220d** and
25 **220e** have (i) a preferred width of from 40 to 200 microns, most preferably a width of approximately 100 microns, and (ii) a preferred depth of from 50 to 100 microns. The indentations **220j** are preferably spaced approximately 10 to 30 microns apart in a rectangular array. Such a pattern on the outermost surfaces **220h** and **220i** of the release
30 layers **220d** and **220e** are particularly useful when applying a pressure-sensitive microsphere adhesive. We believe that microsphere adhesives tend to "wet out" on the outermost surfaces **220h** and **220i** of the release layers **220d** and **220e**, while the microspheres in the adhesive composition tend to gravitate towards and be retained within each of the indentations **220j**. Consequently, adhesive transferred to the overlapped sheets

tend to maintain the surface pattern shown in Figure 28, with a resulting uniform distribution of microspheres and superior adhesion.

It is preferred that the front **220d** and back **220e** release layers be of the same thickness with the same size, shape and pattern of indentations **220j** so that adhesive may be coated onto either the front **220h** or back **220i** outermost surface of the transfer belt **71** as necessary to prolong the useful life of the transfer belt **71** without changing the characteristics of the adhesive strips **236** transferred to the overlapped sheets in the transfer location **70**. Of course, a transfer belt **71** having a release layer **220d** or **220e** on only one major surface **220b** or **220c** can be used if desired.

When a gravure roller **77** is used to apply the adhesive stripes **236** to the transfer belt **71** as described above, the pattern in the adhesive stripes **236** is further influenced by the form of the gravure pattern. Hence both the pattern on the gravure roller **77** and the transfer belt **71** should be chosen with a view to enhancing the even distribution of microspheres in the adhesive stripe **236** applied to the sheets.

Alternatively, other arrangements may be employed, including, for example, a cylindrical drum (not shown) in contact with both the gravure roller **77** and the sheet path. Hence, although the intermediate carrier will hereinafter be referred as a transfer belt **71**, it is to be understood that the present invention is not limited thereto.

Adhesive Transfer Coating System

The adhesive coating system **74** applies at least one longitudinal stripe **236** of a pressure sensitive adhesive to the transfer surface **76** of the transfer belt **71**. The adhesive coating system **74** may be any of a number of suitable coating devices, including, by way of example, a reverse rotating gravure roller **77** as shown in Figure 15, or a coating die **242** as shown in Figures 25 and 26.

Gravure Roller

The gravure roller **77** contacts the transfer belt **71** across substantially the entire width (not shown) of the belt **71**. The gravure roller **77** includes at least one gravure ring **77r**, formed of a plurality of cells or cavities **230**, extending around the full circumference of the gravure roller **77** at the desired location of an adhesive stripe **236** on the transfer belt **71**.

If the gravure roller **77** rotates in the same direction as the transfer belt **71**, the adhesive transfer process is referenced as a direct gravure coating process. If the gravure roller **77** rotates in an opposite rotational direction as the transfer belt **71**, the adhesive

transfer process is referenced as a reverse gravure coating process. Although either arrangement may be employed in the present invention, unless otherwise specified, the process shown and described herein is based upon a reverse gravure process. Typically, the gravure roller 77 is rotated in the same direction and at approximately the same speed as the transfer belt 71, so that the adhesive coating system 74 functions as a reverse gravure process.

Figure 22 depicts three gravure rings 77r, applying three longitudinal adhesive stripes 236 on the transfer belt 71. A magnified view of the surface of the gravure rings 77r, showing the individual cells 230 in the gravure rings 77r, is shown in Figure 24. As can be seen, each cell 230 generally has the form of an inverted truncated pyramid. Typically, there are about twenty-four pattern lines 230A of cells 230 per centimeter length of gravure ring 77r. The particular gravure pattern shown in Figure 24 is not essential and can be changed as desired to alter the distribution of adhesive within the adhesive stripes 236. Alternatively, depending on the intended use of the adhesively coated sheets, the adhesive can be transfer coated across the entire width of the transfer belt 71 rather than in discrete stripes 236.

An adhesive trough 80 is positioned immediately below the gravure roller 77 for supplying adhesive to the surface of a metering roller 81, which then transfers the adhesive to the reverse rotating gravure roller 77. Adhesive is supplied to adhesive trough 80 from an adhesive supply tank 79 by a pump 78. Alternatively, the metering roller 81 may be eliminated and the gravure roller 77 positioned in direct contact with the adhesive in the adhesive trough 80.

One or more doctor blades 82 engage the surface of the gravure roller 77 to remove any excess adhesive from the gravure roller 77 and ensure that the only adhesive on the gravure roller 77 is contained within the gravure ring(s) 77r. This ensures the adhesive will be coated onto the transfer belt 71 as longitudinal stripes 236.

When a reverse gravure coating process is employed, the uniformity of the adhesive stripes 236 applied to the overlapped sheets (unnumbered) can be improved by smoothing the layer of adhesive applied to the gravure rings 77r before the adhesive is transferred to the transfer belt 71. As shown in Figures 22 and 23, the adhesive layer on the gravure roller 77 can be smoothed with smoothing strips 229 which are positioned proximate the gravure roller 77 for contacting the adhesive applied to the gravure rings 77r as the adhesive is transferred on the gravure roller 77 from the metering roller 81 to the transfer belt 71. The smoothing strips 229 can be pivoted relative to the gravure roller 77

for contacting the adhesive applied to the gravure rings 77r before the adhesive is transferred to the transfer belt 71. The smoothing strips 229 are preferably constructed from a flexible polymeric material, and most specifically a strip of polyester which is approximately 0.0011 inches thick.

5 In some applications, smoothing of the adhesive applied to the gravure roller 77 before the adhesive is applied to the transfer belt 71 can enhance distribution of the microspheres contained in a repositionable microsphere adhesive. In other words, when a smoothed microsphere adhesive is coated onto the overlapped sheets, the uniformity of the exposed surface of the adhesive stripes 236 is improved with the beneficial effect of
10 providing adhesive stripes 236 which provide greater control and uniform adhesive strengths.

Die Coater

The adhesive transfer station 7 shown in Figure 25, depicts the use of a coating die
15 242 to apply the pressure-sensitive adhesive to the transfer belt 71. Each coating die 242 has a die slot (not shown) directed towards the transfer belt 71, through which an adhesive stripe 236 is applied to the transfer belt 71. As shown in Figure 26, a plurality of coating dies 242 are spaced across the width of the transfer belt 71 and positioned at the desired locations of the adhesive stripes 236. Each coating die 242 has a suitable adhesive supply
20 line 245, and accompanying pump 246 and filter 247, through which adhesive is supplied to the coating die 242 from an adhesive reservoir 248. Alternatively, a single coating die 242 may be provided with a divided slot for applying adhesive in several separate locations across the width of the transfer belt 71.

The rate at which adhesive is coated onto the transfer belt 71 is readily adjusted by
25 changing the speed of the pumps 246 which are otherwise driven under the control of the central electronic control unit (not shown) of the apparatus in dependence on the line speed of the apparatus.

Die coating of the adhesive stripes 236 increases the flexibility of the coating process by enabling the location of the coating die heads 242 to be quickly and easily
30 adjusted relative to the transfer belt 71.

Alternatively, as shown in Figure 19, the overlapped sheets (unnumbered) can be arranged to provide a relatively small length of surface exposed to the adhesive coated transfer belt 71 and the adhesive coating system 74 configured and arranged to coating the entire length and width of the transfer surface 76. In that case, by providing a large degree

of overlap between adjacent sheets, as illustrated in Figure 19, each sheet will be coated with adhesive along a narrow margin 99 along one edge only of the sheets. The sheets can then be stacked to form a pad, with the sheets held together along the adhesive-coated margin 99.

5

Adhesive Dryer

The adhesive coating (not shown) on the transfer belt 71 is at least partially dried by the adhesive dryer 75. For instance, the moisture content of suitable aqueous adhesives is commonly between about 50 to 80 wt% when applied and is preferably dried by the adhesive dryer 75 to a moisture content of between about 0 to 50 wt%. Preferably, substantially all of the moisture is removed during the drying process. The dried adhesive adheres more readily to the overlapped sheets.

The adhesive dryer 75 is preferably a radio-frequency dryer, for example a particularly adapted version of the Model No. SPW 12-73 manufactured by Proctor Strayfield Ltd. of Berkshire, England operated, typically, at about 27 MHz, or alternatively, at about 30 MHz. The adhesive dryer 75 is about 2.5 m long in the direction of travel of the transfer belt 71 and has an exhaust (not shown) through which the interior of the adhesive dryer 75 is vented with the aid of an exhaust fan 84. The adhesive dryer 75 is provided with a control unit (not shown) which adjusts the power of the adhesive dryer 75 in accordance with the line speed of the coating apparatus. That control unit may, for example, be a Siemens PLC 55-95U interconnected with the central electronic control unit for the entire apparatus.

Use of a radio frequency adhesive dryer 75 permits the adhesive to be dried without significantly heating the transfer belt 71. This eliminates the undesired transfer of heat from the transfer belt 71 to the adhesive coating system 74 where it tends to coagulate the adhesive before it can be applied to the transfer belt 71. Use of a radio frequency adhesive dryer 75 also offers the advantages of comparative simplicity and lower energy consumption. Further, the adhesive transfer station 7 does not require any prolonged preheating and the adhesive is readily released from the transfer belt 71 to the overlapped sheets at the transfer location 70.

30

The use of a radio-frequency adhesive dryer 75 is preferred, but not essential. The adhesive could, instead, be dried using infra-red or forced air heating systems. However, a radio-frequency dryer is preferred for a number of reasons, including its simplicity, lower energy consumption, reduced thermal build-up, etc. In addition, should the adhesive dryer

75 appreciably heat the transfer belt 71, it may be necessary to incorporate a cooling system (not shown) into the adhesive transfer station 7 for purposes of cooling the adhesive transfer belt 71 in order to reduce the risk of coagulating the adhesive.

The adhesive dryer 75 is provided with a control unit (not shown) for automatically adjusting the power of the adhesive dryer 75 in accordance with the line speed of the transfer belt 71. A suitable control unit is available from Siemens under the designation PLC 55 95U. The control unit can be interconnected with the central electronic control unit for the entire system, for purposes of sending and receiving the information necessary to properly monitor and control operation of the system.

The dried adhesive coating is then transported to the transfer location 70 where the adhesive is transferred from the transfer belt 71 to the overlapped sheets.

Transfer Location

A drive roller 90 and idler counter-pressure roller 91 form a transfer nip 85 at the transfer location 70. The adhesive coated transfer belt 71 and the succession of overlapped sheets pass through the transfer nip 85 wherein the dried adhesive on the transfer belt 71 is transferred to the first major surface of the overlapped sheets due to the greater bonding strength between the adhesive and the overlapped sheets relative to the bonding strength between the adhesive and the transfer belt 71.

As shown in Figure 16, the idler counter-pressure roller 91 is provided with a plurality of laterally spaced circumferential grooves 92, and a plurality of fingers 93 positioned immediately downstream of the idler counter-pressure roller 91 and engaged within the grooves 92 for ensuring that the overlapped sheets 86 continue to travel with the transfer belt 71 after exiting the transfer location 70 and do not wrap around the idler counter-pressure roller 91.

Vacuum Belt

As shown in Figure 16, the overlapped sheets 86 are removed from the transfer belt 71 after exiting the transfer location 70 by a vacuum belt 95. Removal of the overlapped sheets 86 from the transfer belt 71 is facilitated by the fact that the trailing edge portion of each sheet is positioned between the leading edge portion of the succeeding sheet 23 and the transfer belt 71. This facilitates initiation of the removal process since removal of the trailing edge portion of each sheet will inherently cause the leading edge portion of the succeeding sheet 23 to be pulled from the transfer belt 71.

The vacuum belt **95** may be selected from a number of commercially available types and styles, such as the system available from Honeycomb Systems Valmet S.a.r.l. of Mulhouse, France, which combines a metallic belt which is entrained around and surrounds a vacuum roller at the leading edge of the metallic belt.

5 An additional roller **97** is provided between the drive roller **90** and the lowermost downstream tension roller **72** to engage the inside of the transfer belt **71** downstream from the front end (unnumbered) of the vacuum belt **95**. The additional roller **97** is positioned relative to the drive roller **90** and downstream tension roller **72** so as to cause the transfer belt **71** to angle away from the front end of the vacuum belt **95** at a small angle of about
10 two to three degrees upstream from the additional roller **97**, and thereafter angle away from the vacuum belt **95** at a greater angle of about five degrees. More specifically, the transfer belt **71** should angle away from the vacuum belt **95** at an angle of about two to three degrees for a distance of about 50 mm to permit the suction exerted by the vacuum belt **95** to attract and remove the overlapped sheets from the transfer belt **71**, and thereafter
15 at an angle of about five degrees in order to increase the distance between the transfer belt **71** and the adhesively coated sheets. The additional roller **97** is preferably movable between a first and second position as indicated generally by pivot line **97p**, in order to enable the initial and final angles between the transfer belt **71** and the vacuum belt **95** to be adjusted as necessary to maximize operation of the process.

20 Referring to Figures 17 and 18, a vacuum belt **95** rests upon a vacuum box **94** which is connected to a source of low pressure (not shown). The vacuum box **94** is divided into a forward chamber **94a** and a rear chamber **94b**, with the forward chamber **94a** connected to a first source of low pressure (not shown) and the rear chamber **94b** connected to a second source of low pressure (not shown). The first source of low
25 pressure pulls a vacuum which is greater than the vacuum pulled by the second source of low pressure. The greater vacuum pulled in the forward chamber **94a** facilitates removal of the adhesive coated sheets from the transfer belt **71** as the sheets exit the transfer location **70**. In order to further facilitate the greater initial suction required on the vacuum belt **95**, the openings **94x** in the top (unnumbered) of the forward chamber **94a** are larger
30 than the openings **94y** provided in the rear chamber **94b**.

The vacuum belt **95** also includes a plurality of apertures **98** so that the reduced pressure applied to the back side (unnumbered) of the vacuum belt **95** through the top of the vacuum box **94** will communicate through the vacuum belt **95** and interact with any sheets positioned on the upper surface of the vacuum belt **95**. The reduced pressure

applied by the low pressure source through the vacuum belt 95 is comparatively strong over the initial length (unnumbered) of the vacuum belt 95, and is then decreased over the remaining length of the belt 95. The initial vacuum must be sufficient to detach the overlapped sheets and accompanying adhesive strips from the transfer belt 71 without
5 damaging the sheets. Once the overlapped sheets and accompanying adhesive have been delaminated from the transfer belt 71, the vacuum need only maintain the detached sheets on the vacuum belt 95. While the acceptable and optimal reduced pressure levels depends upon a number of factors, including the specific type of adhesive being applied and the characteristics of the sheet material being coated, an initial reduced pressure in the range
10 of from 350 to 550 mm H₂O (typically 400 mm H₂O) will generally be acceptable, with a reduced pressure in the range of from 150 to 200 mm H₂O generally acceptable over the remainder of the run.

The vacuum belt 95 may be configured as a single belt covering the entire width of the vacuum box 94, or a plurality of narrower belts arranged side-by-side across the width
15 of the vacuum box 94

Once detached from the vacuum belt 95, the sheets may be stacked and trimmed to form pads of repositionable notes, for example those available under the designation Post-It® notes available from the Minnesota Mining and Manufacturing Company of St. Paul, Minnesota.

20 The particular sheet removal system described herein and illustrated in Figures 15 and 16 is not essential, and can be replaced by other suitable systems, such as (i) mechanical grippers (not shown), (ii) a vacuum roller 239 to detach the overlapped sheets from the transfer belt 71 combined with a separate standard conveyor 96 to transport the detached sheets to the desired location, as shown in Figures 21 and 25, or (iii) the vacuum
25 roller 239 combined with a separate vacuum belt 95. However, such other systems would not provide the benefits associated with the system described herein and illustrated in Figures 15 and 16.

The sheet removal systems described herein could also be used with other sheet coating apparatuses other than the specific apparatus described herein.

30

Adhesive

The adhesive may be substantially any pressure-sensitive adhesive. When producing repositionable notes, such as Post-It® notes, the adhesive is preferably a repositionable, microsphere, pressure-sensitive adhesive such as those described in United

States Patents 5,045,569; 4,495,318, 4,166,152, 3,857,731, 3,691,140, Reissue 24,906 and European Patent Publication 439,941. Other suitable adhesives include film-forming materials known in the art, including those containing organic solvents.

5 SHEET STACKING STATION

As shown in Figure 5, the adhesive coated sheets (unnumbered) exiting the adhesive transfer station 7 are transported to a sheet stacking station 9 where the adhesive coated sheets are stacked 140 and prepared for cutting into note pads of the desired size and shape.

10

SECONDARY SHEET INSERTING STATION

As shown in Figure 5, a secondary sheet inserting station 150 can be positioned between the adhesive coating station 7 and the sheet stacking station 9 for periodically inserting sheets, such as backer sheets, into the paper path just prior to stacking of the

15

THE SHEETS

Although the apparatus has been described in connection with the coating of paper sheets, the apparatus is capable of coating sheets constructed from other materials, such as

20

polymeric films and metallic foils. Papers of different sizes, weights and textures can be used if desired. For example, the described apparatus is readily adaptable to handle sheets of A2 and A4 size paper. Likewise, the apparatus is able to handle sheets of a comparatively high weight (e.g., 90 gsm) as well as sheets of a low weight (e.g., 70 gsm).

25

Operation

THE SHEET FEEDING STATION

The suction head 12 lifts the rear edge (unnumbered) of the top sheet (unnumbered) from the stack 11 and moves the lifted sheet forward. Movement of the

30

lifted sheet is assisted by a jet of air from jet nozzle 12a. The lifted sheet is then taken up by the paired feed rollers 13 and conveyed out of the sheet feeding station 1 and onto a first conveyor 14. The suction head 12 returns to its original position, picks up the next sheet, and feeds the next sheet to the paired feed rollers 13 before the first sheet is fed completely through the paired feed rollers 13. In that way, the trailing edge (not shown) of

each sheet overlaps the leading end (not shown) of the succeeding sheet 23 as the sheets pass between the paired feed rollers 13 and are fed onto the first conveyor 14.

As the height of the stack 11 decreases, the table 10 moves upwards to maintain the top (unnumbered) of the stack 11 in a predetermined vertical location relative to the suction head 12.

THE FIRST CONVEYOR AND STOP GATE

Sheets exiting the sheet feeding station 1 are deposited on the first conveyor 14 and transported to the stop gate 15 at the entry to the dual coating station 3. As each sheet arrives at the stop gate 15, its forward progress is temporarily halted while the coating drum 33 rotates to the correct position for transporting and coating the sheet. The stop gate 15 then opens to allow a single accumulated sheet to enter the dual coating station 3. The stop gate 15 then closes in advance of the arrival of a succeeding sheet 23 and temporarily halts the forward progress of that sheet until the coating drum 33 has once again rotated to the correct position.

THE DUAL COATING STATION

Stop gate 15 releases a sheet into the dual coating station 3 in timed relationship to the rotational position of the coating drum 33, with a sheet fed into the dual coating station 3 on every rotation of the coating drum 33. The pad 38 on the coating drum 33 contacts the lower coating roller 35 and is coated with LAB. As the LAB coated pad 38 approaches the upper coating roller 32, a sheet is fed through the nip roll pair 30 and the leading edge of the sheet picked up by the sheet gripper 37. The sheet is carried through the coating nip formed between the upper coating roller 32 and the pad 38 on the coating drum 33 and is coated on a first major surface with primer. The force of the coating nip also causes the LAB coating on the pad 38 to transfer to the second major surface of the sheet. The dual coated sheet is then released by the sheet gripper 37 and removed from the coating drum 33 by a clasp 52. This procedure is repeated for each sheet fed into the dual coating station 3.

In the event that no sheet is waiting at the stop gate 15, that fact is detected by a photocell (not shown) positioned at the stop gate 15, and the upper coating roller 32 is moved away from the coating drum 33 to prevent any mixing of the primer and LAB materials.

THE SHEET SPACING STATION

Sheets exiting the dual coating station 3 enter the sheet spacing station 4 in which a clasping unit 50 is positioned to grab the dual coated sheets as they emerge from the coating nip, and deposit them on a second conveyor 51. Movement of the chain 53 is synchronized with rotation of the coating drum 33 so that a clasp 52 is positioned to receive each dual coated sheet as the sheet leaves the coating nip. The LAB coating on the underside of the dual coated sheet is partially dried by a heater (not shown) before it is deposited onto the second conveyor 51.

The speed of the second conveyor 51 relative to the line speed of the chain 53 of the clasping unit 50 determines whether the coated sheets are transported to the drying station 5 as individual sheets or a pseudo-web of overlapped sheets. When the second conveyor 51 is run at a slower speed than the chain 53 of the clasping unit 50, a leading edge portion of each sheet overlaps a trailing edge portion of the preceding sheet 22 and forms a pseudo-web of overlapped sheets on the second conveyor 51. When the second conveyor 51 is run at the same speed or faster than the chain 53 of the clasping unit 50, a gap is maintained between the sheets deposited on the second conveyor 51.

THE OVERLAP REVERSAL SYSTEM

When the sheets are fed as a pseudo-web of overlapped sheets, an air knife 60 is timed to direct a discrete jet of air against the overlapped edge portions of each pair of overlapped sheets 22 and 23. This occurs whenever the preceding sheet 22 has just moved onto the third conveyor 56 and the succeeding sheet 23 has just begun to move off the second conveyor 51. The air jet emanating from the air knife 60 causes the trailing edge portion of the preceding sheet 22 and the leading edge portion of the succeeding sheet 23 to be lifted up from the sheet path as shown by the dotted lines in Figure 13. The trailing edge portion of the preceding sheet 22 comes under the influence of the suction emanating from the vacuum cylinder 61 and is pulled towards the vacuum cylinder 61, where the trailing edge of the succeeding sheet 23 is held against the surface of the vacuum cylinder 61 while the leading edge portion of the succeeding sheet 23 returns to the sheet path. The preceding sheet 22 continues to be conveyed forward by the third conveyor 56, which causes the trailing edge portion of the preceding sheet 22 to slide across the surface of the

vacuum cylinder **61** until it slides past the last row of apertures **63** on the vacuum cylinder **61** and returns to the sheet path. The trailing edge portion of the preceding **22** now rests above, rather than below, the leading edge portion of the succeeding sheet **23**.

5 DRYING STATION

The sheets (either individually or in the form of a pseudo-web of overlapped sheets) is transported by the third conveyor **56** from the sheet spacing station **4** and through the drying station **5** where moisture is removed from the primer and LAB coatings on the sheets. The overlapped sheets are moved continuously through the drying station **5**
10 by the third conveyor **56** and are dried at a rate which attenuates the tendency of the sheets to curl.

SHEET OVERLAPPING STATION

When the sheets have been fed individually through the drying station **5**, a sheet
15 overlapping station **8** is positioned between the drying station **5** and the adhesive transfer station **7** for overlapping the sheets before they enter the adhesive transfer station **7**.

The individual sheets exiting the drying station **5** are taken-up by a pair of input rollers **110** and pass the sheets between a pair of drive rollers **111**. The drive rollers **111** transport the sheets to a lever **112**. The lever **112** pivots between a first position where the
20 lever **112** projects into the sheets path and stops the forward progress of sheets along the sheet path, and a second position where the lever **112** is positioned below the sheet path so as to allow any accumulated sheets to proceed forward towards the adhesive transfer station **7**.

The drive rollers **111** pivot between an open position and a closed position in
25 response to the position of the lever **112** so as to rotate without propelling the sheets forward when the lever **112** is pivoted into the first position, and to propel the sheets forward along the paper path when the lever **112** is pivoted into the second position below the sheet path.

The lever **112** is returned to the first position while a portion of a preceding sheet
30 **22** is still positioned over the lever **112** so that a trailing portion of the preceding sheet **22** is lifted up from the sheet path by the lever **112**. The lever **112** is then pivoted to the second position and the drive rollers **111** closed while a trailing edge portion of the preceding sheet **22** is still above the lever **112** so that the trailing edge portion of the preceding sheet **22** will overlap a leading edge portion of the succeeding sheet **23**.

ADHESIVE TRANSFER STATION

The registered and overlapped sheets pass through a transfer location **70** where they contact an endless transfer belt **71** to which an adhesive coating has previously been applied in the form of a plurality of adhesive stripes **236** extending longitudinally along the transfer belt **71** and at least partially dried. The adhesive stripes **236** transfer from the transfer belt **71** to the pseudo-web of overlapped sheets and sheets removed from the transfer belt **71** along with the adhesive stripes **236** by a vacuum belt **95** and/or a vacuum roller **239**.

10

SHEET STACKING STATION

The adhesive coated sheets exiting the adhesive transfer station **7** are transported to a sheet stacking station **9** where the adhesive coated sheets are stacked **140** and prepared for cutting into note pads of the desired size and shape.

15

CLAIMS:

1. A method for producing coated sheets, comprising:
 - (a) sequentially feeding sheets having first and second major surfaces from a first stack onto a sheet path and continuing to convey the sheets along the sheet path in a machine direction;
 - (b) inserting at least one sheet having first and second major surfaces from a second stack into the sheets being conveyed along the sheet path to form a sequence of sheets arranged in end-to-end overlapping relationship to each other; and
 - (c) individually applying coating material to at least one major surface of each sheet in the overlapped sequence of sheets as the sheets continue to be conveyed along the sheet path so as to form coated sheets.
2. The method of claim 1, further including temporarily discontinuing the feeding of sheets from the first stack in timed relationship to the insertion of a sheet from the second stack such that the spacing of the sheets in the sequence of overlapped sheets is uniform.
3. The method of claim 1 further including changing the speed at which the sequence of overlapped sheets is conveyed along the sheet path in relation to the length of the sheets in the machine direction.
4. The method of claim 1 wherein the sheet inserted from the second stack is inserted into the sheet path at a right angle to the machine direction.
5. A method of claim 1 in which water-based coating material is applied to both major surfaces of each sheet.
6. The method of claim 5 wherein a primer material is applied to the first major surface of the sheets, and a low adhesion backsize material is applied to the second major surface.
7. The method of claim 5 further including drying the coated sheets as they continue to be conveyed along the sheet path so as to form dry sheets.

8. The method of claim 7 wherein: (i) the dry sheets are arranged in end-to-end overlapping relationship to each other, and (ii) a further coating material is applied continuously to at least one of the major surfaces of the dry sheets as they continue to be conveyed along the sheet path.
- 5
9. The method of claim 8 in which the further coating material is an adhesive.
10. The method of claim 9 in which the adhesive is a repositionable adhesive.
- 10 11. An apparatus for producing coated sheets, comprising:
- (a) a conveyor;
 - (b) a sheet feeder operable to sequentially feed sheets from a first stack onto the conveyor in end-to-end overlapping relationship to form overlapped sheets;
 - (c) a sheet inserter operable to insert at least one sheet from a second stack
15 into the overlapped sheets on the conveyor to form an overlapped sequence of sheets; and
 - (d) a coating system positioned to receive the overlapped sequence of sheets from the conveyor and operable to individually apply a coating material to at least one major surface of each sheet.
- 20
12. The apparatus of claim 11 in which the speed of the conveyor between the sheet feeder and the coating system is adjustable to compensate for different sheet lengths.
13. The apparatus of claim 11 in which the sheet inserter is located to one side of the
25 conveyor whereby sheets fed from the first stack onto the conveyor are fed at right angles to the direction of travel of the conveyor.
14. The apparatus of claim 11 wherein the coating system is a dual coater operable to apply a water-based coating material to both major surfaces of each sheet.
- 30
15. The apparatus of claim 14 further including a dryer positioned to receive sheets from the dual coater and operable to remove water from a coating material applied to the sheets in the dual coater.

16. The apparatus of claim 15 further including: (i) a secondary coater positioned to receive sheets exiting from the dryer and operable to apply a further coating material to at least one major surface of each sheet member, and (ii) a sheet overlapping station located downstream from the dual coater and operable to arrange the sheets in end-to-end overlapping relationship for entry into the secondary coater.
17. The apparatus of claim 16 in which the sheet overlapping station is located upstream from the dryer.
18. A method for applying an aqueous coating material to both major surfaces of a plurality of sheets, comprising:
- (a) sequentially conveying a plurality of sheets, having first and second major surfaces, along a sheet path and in a machine direction;
 - (b) applying an aqueous coating material to the first and second major surfaces of each sheet as the sheets are conveyed along the sheet path so as to form coated sheets;
 - (c) drying the coated sheets while continuing to convey the sheets along the sheet path so as to form dry coated sheets;
 - (d) arranging the dry coated sheets in sequential end-to-end overlapping relationship so as to form an overlapped sequence of dry coated sheets; and
 - (e) continuously applying a further coating material to at least one of the major surfaces of the overlapped sequence of dry coated sheets.
19. The method of claim 18 wherein the aqueous coating material is applied simultaneously to both the first and second major surfaces of the sheets.
20. The method of claim 18 wherein the aqueous coating material applied to the first major surface is a primer, and the aqueous coating material applied to the second major surface is a low adhesion backsize.
21. The method of claim 20 wherein a plurality of the sheets are pre-printed on the second major surface.

22. The method of claim 20 wherein (i) the further coating material is an aqueous adhesive, (ii) the further coating material is applied to the first major surface, and (iii) the adhesive is applied in the machine direction as independent and distinct stripes which cover less than the entire width of the sheets.

5

23. The method of claim 19 wherein the coated sheets are dried so as to simultaneously dry the first and second major surfaces of each coated sheet.

10

24. The method of claim 18 wherein arranging the sheets in sequential end-to-end overlapping relationship includes (i) raising a trailing edge of each sheet away from the sheet path, (ii) inserting a leading edge of an immediately following sheet between the raised trailing edge of each sheet and the sheet path, and (iii) allowing the raised trailing edge to return to the sheet path; whereby the trailing edge of each sheet is positioned over the leading edge of each immediately following sheet.

15

25. The method of claim 18 wherein the sheets are overlapped a distance of between about 1 cm to 2 cm.

20

26. The method of claim 18 further including inserting at least one sheet from a second stack of sheets into the sheets being conveyed along the sheet path prior to applying the aqueous coating material to the sheets.

25

27. The method of claim 18 further including collecting and stacking the dry coated sheets before they are overlapped.

30

28. An apparatus for applying an aqueous coating material to both first and second major surfaces of a plurality of sheets, comprising:

(a) a dual coating station adapted to receive and coat both major surface of sequentially fed sheets, wherein the dual coating station comprises first and second coating systems configured and arranged to apply an aqueous coating material to the first and second major surfaces of each sheet respectively;

(b) a drying station configured and arranged to receive sheets exiting from the dual coating station and operable to remove water from the aqueous coating material applied to the sheets in the dual coating station;

(c) an overlapping mechanism configured and arranged to receive sheets exiting from the drying station and operable for arranging the sheets in sequential end-to-end overlapping relation; and

5 (d) a further coating station configured and arranged to receive overlapped sheets exiting from the overlapping mechanism and operable to continuously apply a further coating material to the first major surface of the overlapped sheets.

29. The apparatus of claim 28 wherein (i) the first and second coating systems each comprise a coating roller, and (ii) the coating rollers are disposed in opposed relationship
10 on opposite sides of the sheet path so as to form a nip effective for pulling sheets through the dual coating station and simultaneously applying coating material to both major surfaces of the sheets as they pass through the nip.

30. The apparatus of claim 28 wherein the overlapping mechanism is effective for
15 positioning a trailing edge of each sheet over a leading edge of an immediately following sheet.

31. The apparatus of claim 28 further including a stacking station configured and arranged to receive sheets as the exit from the drying station and operable to stack the
20 sheets and sequentially feed the stacked sheets onto a paper path in end-to-end overlapping relation.

32. The apparatus of claim 28 wherein the further coating station includes: (i) a conveyor for moving overlapped sheets through a transfer location; (ii) a transfer surface
25 configured and arranged to be conveyed through the transfer location and contact any overlapped sheets being conveyed through the transfer location on the conveyor; and (iii) an applicator configured and arranged to apply a further coating material to the transfer surface for subsequent transfer from the transfer surface onto any sheets being conveyed through the transfer location on the conveyor.

30 33. The apparatus of claim 28 further including: (i) a sheet feeder for sequentially feeding sheets from a primary sheet source into the dual coating station, and (ii) a sheet inserter positioned upstream from the dual coating station which is operable for inserting

sheets from a secondary sheet source into the sequence of sheets fed from the primary sheet source.

34. A sheet handling apparatus comprising:

- 5 (a) a first conveyor for transporting a succession of overlapped sheets along a sheet path, wherein a trailing edge portion of each sheet is positioned underneath a leading edge portion of a succeeding sheet;
- (b) a second conveyor configured and arranged to receive the overlapped sheets from the first conveyor; and
- 10 (c) a mechanism positioned between the first and second conveyors for changing the relative overlapping positions of the overlapped sheets, which includes:
- (1) a blower for directing a current of air at the overlapped edge portions of each pair of overlapped sheets so as to lift the overlapped edge
- 15 portions from the sheet path, and;
- (2) a means for retarding the subsequent return of the lifted trailing edge portion of each sheet for a time period sufficient to allow the leading edge portion of the succeeding sheet to return to the sheet path before the trailing edge portion, whereby the trailing edge portion of each sheet rests
- 20 on top of the leading edge portion of the succeeding sheet on the second conveyor.

35. The apparatus of claim 34 wherein the means for retarding the return of the lifted trailing edge portion of each sheet comprises a vacuum device effective for attracting and

25 retaining the lifted trailing edge portion of the sheet without attracting and retaining the lifted leading edge portion of the succeeding sheet.

36. The apparatus of claim 35 wherein (i) the vacuum device is a vacuum cylinder which is connected to a source of reduced pressure for exerting suction and has (A) first

30 and second ends, (B) a sidewall, (C) a longitudinal axis extending through the first and second ends, and (D) a plurality of apertures through the sidewall of the cylinder which are in fluid communication with the source of reduced pressure; and (ii) the vacuum cylinder longitudinally extends across the width of the sheet path and is positioned relative to the

sheet path and the blower such that the suction exerted through the apertures attracts and retards return of the lifted trailing edge portion of the sheets.

37. The apparatus of claim 35 wherein the lifted trailing edge of the sheets retained by the vacuum device are removed from the vacuum device by forward movement of the sheet on the second conveyor.

38. The apparatus of claim 37 wherein the second conveyor includes a conveying surface and a vacuum system which applies a reduced pressure to the conveying surface wherein the force exerted by the vacuum system is sufficient to remove sheets from the vacuum device as the sheets are moved forward by the second conveyor.

39. The apparatus of claim 35 further including a deflector surface configured and arranged to direct air from the blower towards the vacuum device.

15

40. An apparatus for coating sheets comprising:

- (a) a first conveyor for transporting a succession of overlapped sheets along a sheet path;
- (b) a coating station operable to (i) apply a coating material to both major surfaces of a plurality of sheets to form coated sheets, and (ii) deposit the coated sheets onto the first conveyor with a trailing edge portion of each sheet lying underneath a leading edge portion of a succeeding sheet to form the succession of overlapped sheets;
- (c) a second conveyor configured and arranged to receive the succession of overlapped sheets from the first conveyor and continue conveying the succession of overlapped sheets along the sheet path; and
- (d) a mechanism positioned between the first and second conveyors for changing the relative overlapping positions of the overlapped sheets, which includes:
 - (1) a blower for directing a current of air at the overlapped edge portions of each pair of overlapped sheets so as to lift the overlapped edge portions away from the sheet path, and;
- (e) a means for retarding return of the lifted trailing edge portion of each sheet for a time period sufficient to allow the lifted leading edge portion of the

30

succeeding sheet to return to the sheet path before the trailing edge portion, whereby the trailing edge portion of each sheet rests on top of the leading edge portion of the succeeding sheet on the second conveyor.

- 5 41. The apparatus of claim 40 wherein the means for retarding the return of the lifted trailing edge portion of each sheet comprises a vacuum device effective for attracting and retaining the lifted trailing edge portion of the sheet without attracting and retaining the lifted leading edge portion of the succeeding sheet.
- 10 42. The apparatus of claim 41 wherein (i) the vacuum device is a vacuum cylinder which is connected to a source of reduced pressure for exerting suction and has (A) first and second ends, (B) a sidewall, (C) a longitudinal axis extending through the first and second ends, and (D) a plurality of apertures through the sidewall of the cylinder which are
15 longitudinally extends across the width of the sheet path and is positioned relative to the sheet path and the blower such that the suction exerted through the apertures attracts and retards return of the lifted trailing edge portion of the sheets.
- 20 43. The apparatus of claim 41 wherein the lifted trailing edge of the sheets retained by the vacuum device are removed from the vacuum device by forward movement of the sheet on the second conveyor.
- 25 44. The apparatus of claim 43 wherein the second conveyor includes a conveying surface and a vacuum system which applies a reduced pressure to the conveying surface wherein the force exerted by the vacuum system is sufficient to remove sheets from the vacuum device as the sheets are moved forward by the second conveyor.
- 30 45. The apparatus of claim 41 further including a deflector surface configured and arranged to direct air from the blower towards the vacuum device.
46. The apparatus of claim 40 further including a dryer configured and arranged to dry the coated sheets as the sheets are being conveyed along the sheet path by the second conveyor.

47. The apparatus of claim 46 further including a further coating station positioned and arranged to receive the succession of overlapped sheets exiting from the dryer and operable to continuously apply a further coating material to a first major surface of the sheets.

5

48. A method of coating sheets comprising the steps of:

(a) sequentially conveying a plurality of sheets, each having first and second major surfaces, along a sheet path and in a machine direction;

10

(b) applying an aqueous coating material to the first and second major surfaces of each individual sheet as the sheets are conveyed along the sheet path so as to form coated sheets;

(c) arranging the coated sheets with a trailing edge portion of each sheet underneath a leading edge portion of a succeeding sheet; and

15

(d) changing the relative overlapping positions of the sheets by (i) lifting the overlapped edge portions of each sheet away from the sheet path, (ii) retarding return of the lifted trailing edge portion of each sheet for a time period sufficient to allow the lifted leading edge portion of the succeeding sheet to return to the sheet path before the trailing edge portion, and then (iii) allowing the lifted trailing edge portion of the sheet to return to the paper path and rest on top of the leading edge portion of the succeeding sheet.

20

49. An apparatus for applying coating material to a succession of overlapped sheets, the apparatus comprising:

25

(a) a conveyor for transporting a succession of overlapped sheets along a sheet path and through a transfer location, wherein a trailing edge portion of each sheet is positioned over a leading edge portion of a succeeding sheet;

(b) a transfer surface configured and arranged to pass through the transfer location and contact overlapped sheets being conveyed through the transfer location on the conveyor;

30

(c) an applicator configured and arranged to apply a coating material to the transfer surface for subsequent transfer from the transfer surface onto overlapped sheets as the overlapped sheets are conveyed through the transfer location on the conveyor; and

- 5 (d) a detachment mechanism configured and arranged to interact with the overlapped sheets as the sheets exit the transfer location so as to initially apply suction to the sheets at a first magnitude sufficient to detach the sheets from the transfer surface, and thereafter apply suction to the sheets at a second magnitude sufficient to maintain the sheets in position as the sheets are transported away from the transfer location.
- 10 50. The apparatus of claim 49 wherein the transfer surface is conveyed through the transfer location along a first plane and the apparatus further includes a second conveyor upon which the sheets are deposited as the sheets exit the transfer location and which moves along a second plane which is angled away from the first plane.
- 15 51. The apparatus of claim 50 wherein the second conveyor transitions from the second plane to a third plane as the conveyor moves away from the transfer location, with the angle between the first and third planes greater than the angle between the first and second planes.
- 20 52. The apparatus of claim 50 wherein the angle between the first and second planes is between 1 and 6 degrees.
53. The apparatus of claim 49 wherein the suction has a first magnitude of between about 350 to 550 mm H₂O.
- 25 54. The apparatus of claim 53 wherein the suction has a second magnitude of between about 150 to 200 mm H₂O.
55. The apparatus of claim 49 further comprising:
- 30 (a) a roller configured and arranged so as to form a nip with the transfer surface for supporting the overlapped sheets in contact with the transfer surface, and;
- (b) a sheet engaging means, positioned downstream from the roller, for maintaining the overlapped sheets in contact with the transfer surface as the sheets exit the nip.

56. The apparatus of claim 55 wherein: (i) the roller includes a series of circumferential grooves, and (ii) the sheet engaging means comprises a plurality of fingers cooperatively engaged within the circumferential grooves for maintaining the overlapped sheets in contact with the transfer surface after the sheets exit the nip.

5

57. The apparatus of claim 49 wherein the applicator is effective for applying coating material to the transfer surface in one or more longitudinal stripes.

58. The apparatus of claim 57 further including a reservoir for supplying coating material to the applicator.

10

59. The apparatus of claim 58 further including an adhesive within the reservoir as the coating material supplied to the applicator.

60. A method for applying coating material to sheets, comprising:

- (a) applying a coating material to an endless transfer surface;
- (b) conveying a succession of overlapped sheets along a sheet path and through a transfer location, wherein the sheets in the succession of overlapped sheets have a trailing edge portion positioned over a leading edge portion of a succeeding sheet;
- (c) contacting the overlapped sheets against the transfer surface at the transfer location so as to transfer the coating material on the transfer surface to the overlapped sheets;
- (d) applying suction to the overlapped sheets as they exit the transfer location sufficient to detach the overlapped sheets and the coating material from the transfer surface; and
- (e) applying a reduced suction to the overlapped sheets further downstream from the transfer location sufficient to maintain the overlapped sheets in position as the sheets are transported away from the transfer location.

15

20

25

30

61. An apparatus for applying a coating material to a first major surface of a sequence of sheets, comprising:

- (a) a first roller;

- (b) a second roller having an outer surface and a circumference, and configured and arranged relative to the first roller so as to define a coating nip;
- (c) a support sheet releasably secured to the outer surface of the second roller; and
- 5 (d) a pad of elastomeric material covering a circumferential portion of the second roller and adhesively bonded to the support sheet, whereby the coating nip is formed only when the pad-covered portion of the second roller is abutting the first roller.
- 10 62. The apparatus of claim 61, further comprising: (i) a source of coating material, and (ii) an applicator effective for applying coating material from the source of coating material to the pad.
63. The apparatus of claim 61 wherein the support sheet is a flexible sheet of plastic.
- 15 64. The apparatus of claim 61 wherein the support sheet is secured to the second roller by threaded fasteners.
65. The apparatus of claim 62 wherein the coating material is an aqueous material.
- 20 66. The apparatus of claim 65 wherein the aqueous material is a low adhesion backsize.
67. The apparatus of claim 62, further comprising: (i) a source of further coating material, and (ii) an applicator effective for applying the further coating material from the
- 25 source of further coating material to the first roller.
68. The apparatus of claim 67 wherein the further coating material is a second aqueous material.
- 30 69. The apparatus of claim 68 wherein the second aqueous material is a primer.
70. The apparatus of claim 61, further comprising:

AMENDED CLAIMS

[received by the International Bureau on 28 July 1997 (28.07.97);
original claims 73-122 cancelled; remaining claims unchanged (1 page)]

- (a) a sensor effective for detecting the presence or absence of a sheet to be fed into the coating nip and transmitting a secondary signal when a sheet is absent; and
- (b) a means in communication with the sensor for separating the first and second rollers so as to discontinue contact between the first roller and the pad on the second roller in response to receipt of the secondary signal from the sensor.
- 5
71. The apparatus of claim 61, further comprising a means for controlling the entry of sheets into the coating nip in timed relationship to rotation of the second roller, so as to ensure that the entire length of the sheet rests upon the pad.
- 10
72. A method for applying a coating material to sheets, comprising:
- (a) conveying sheets one at a time through a coating nip formed by a first and a second roller, wherein: (i) a support sheet is releasably secured to an outer surface of the second roller, and (ii) a pad of elastomeric material covers a circumferential portion of the outer surface of the second roller and is adhesively bonded to the support sheet, whereby the coating nip is formed only when the pad-covered portion of the second roller is abutting the first roller;
- 15
- (b) applying a coating material to the pad; and
- (c) transferring coating material from the pad to a sheet being conveyed through the coating nip.
- 20

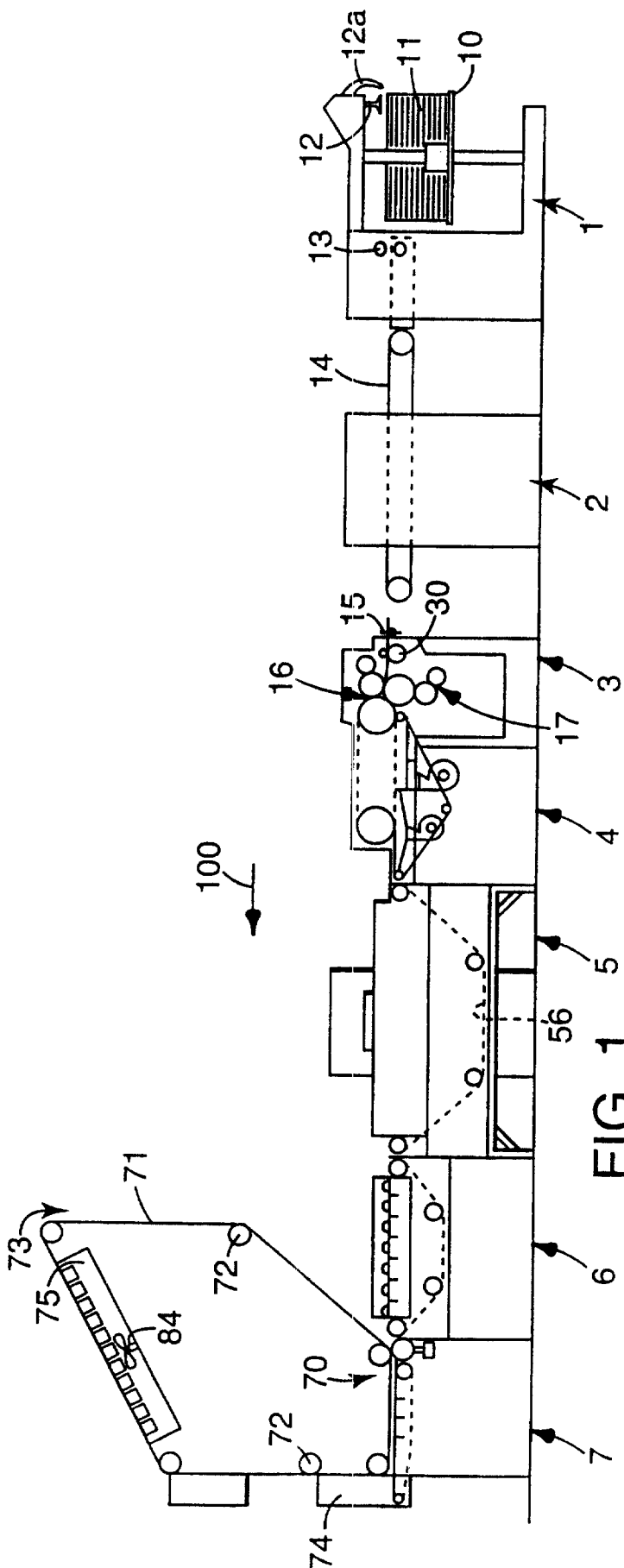

FIG. 1

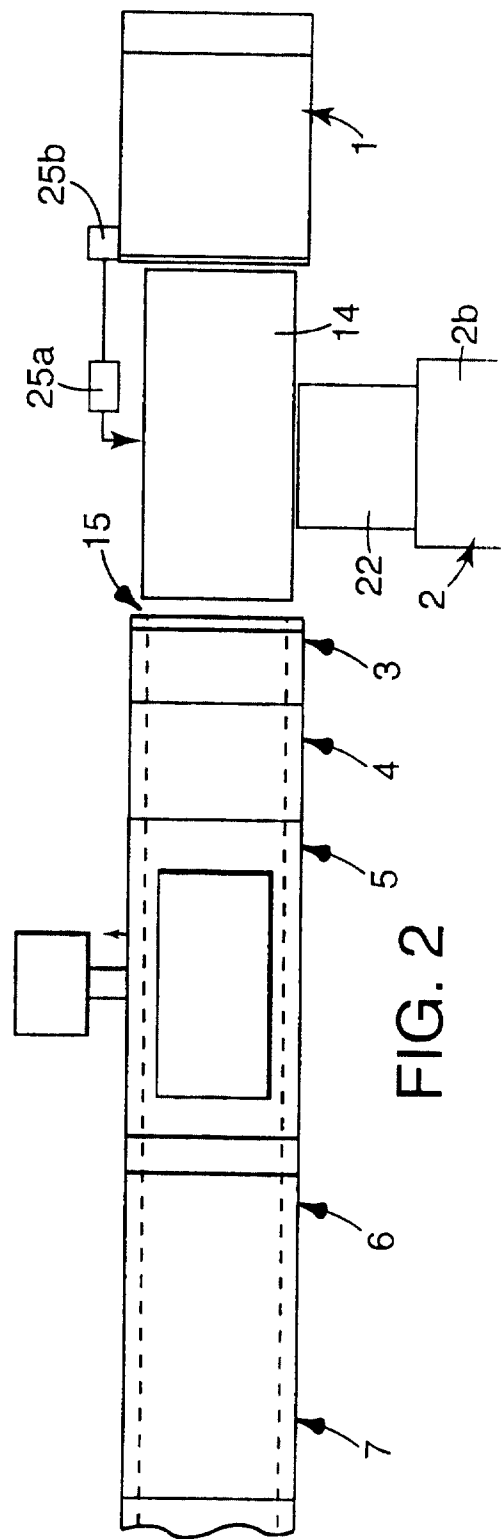

FIG. 2

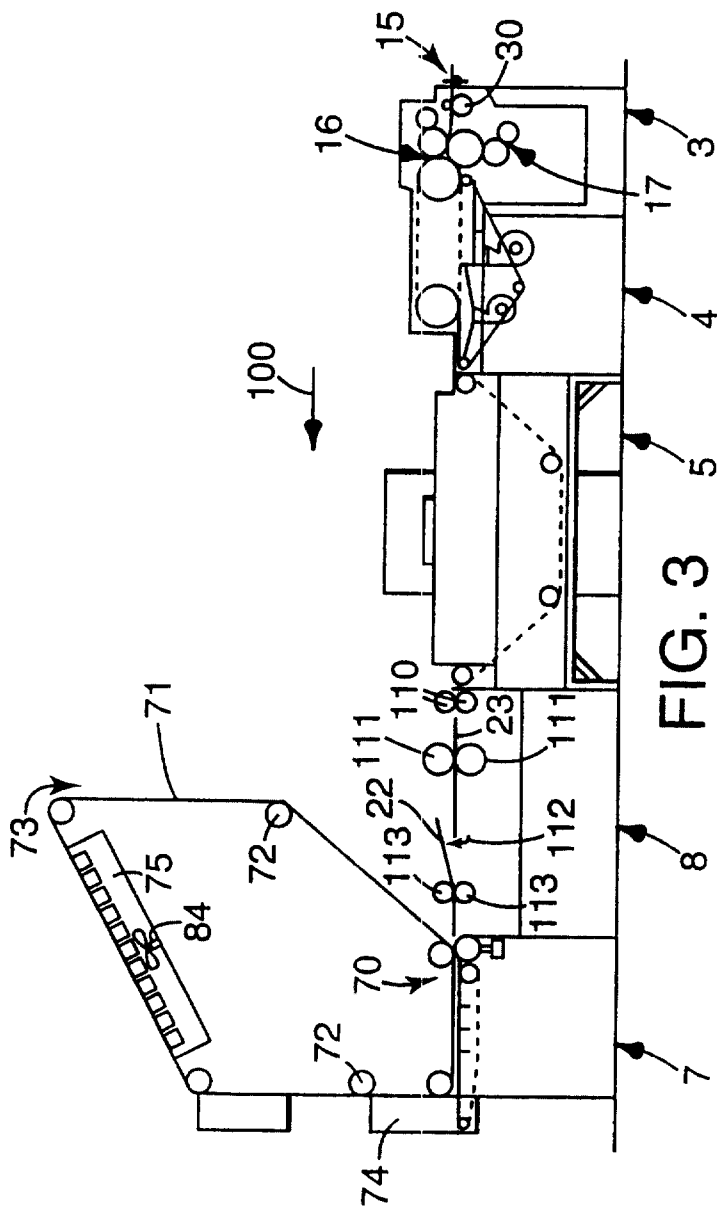

FIG. 3

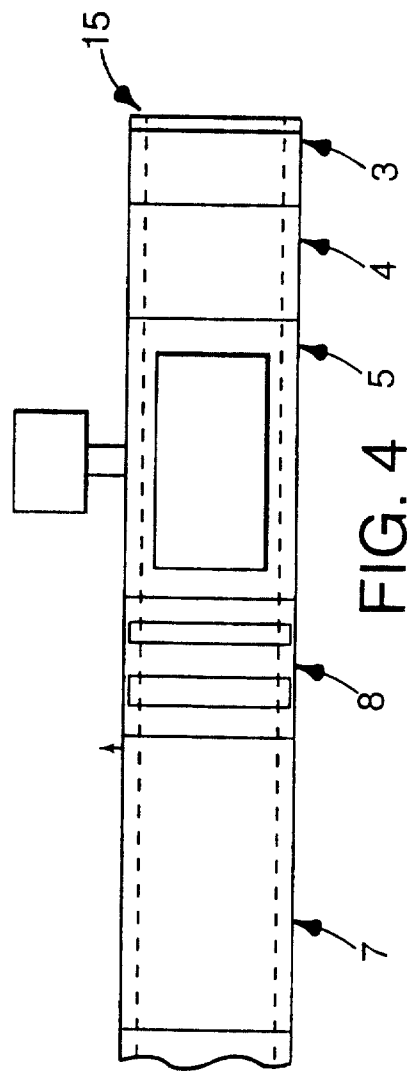
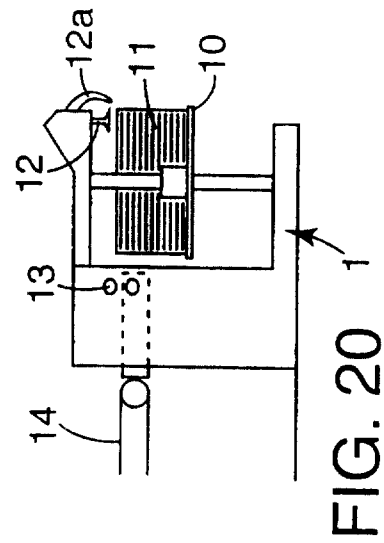
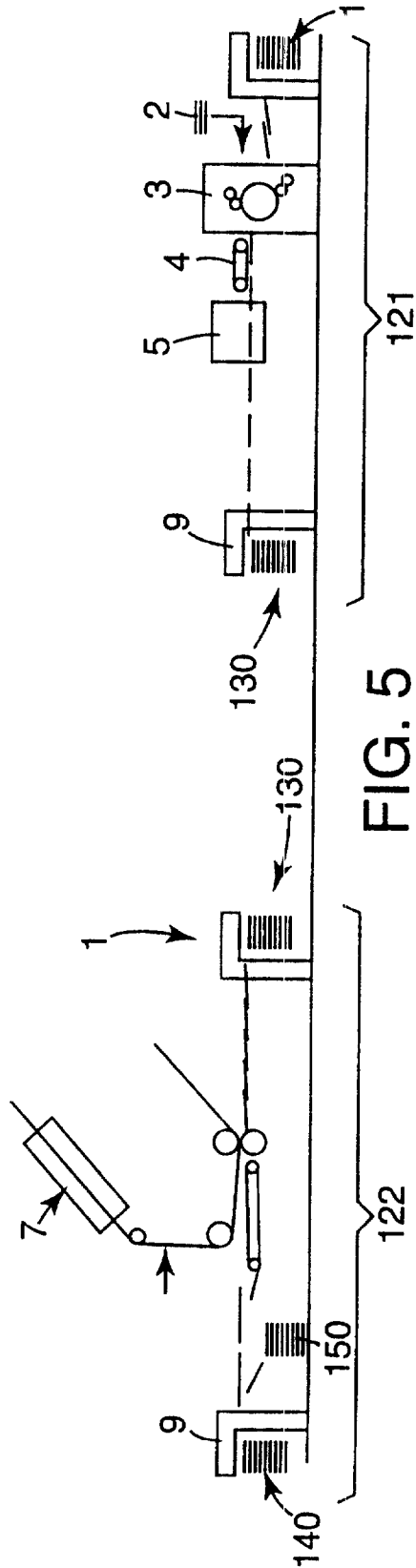
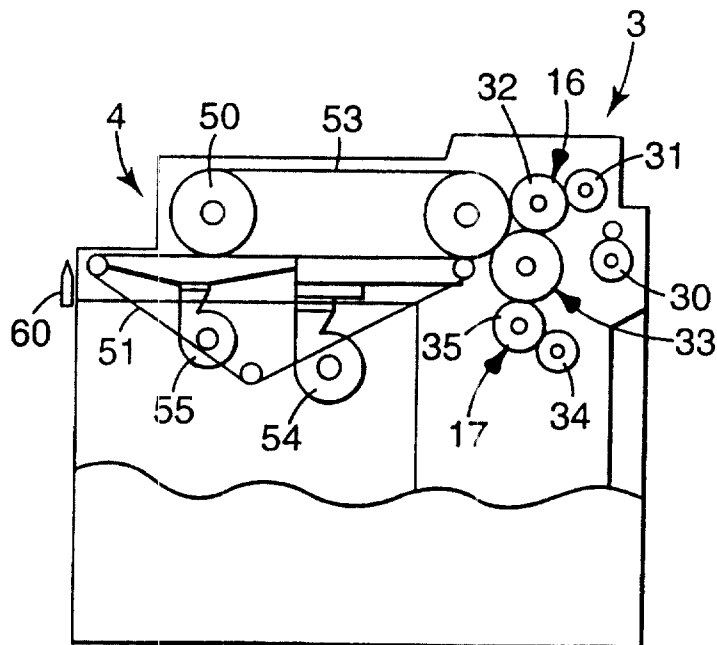
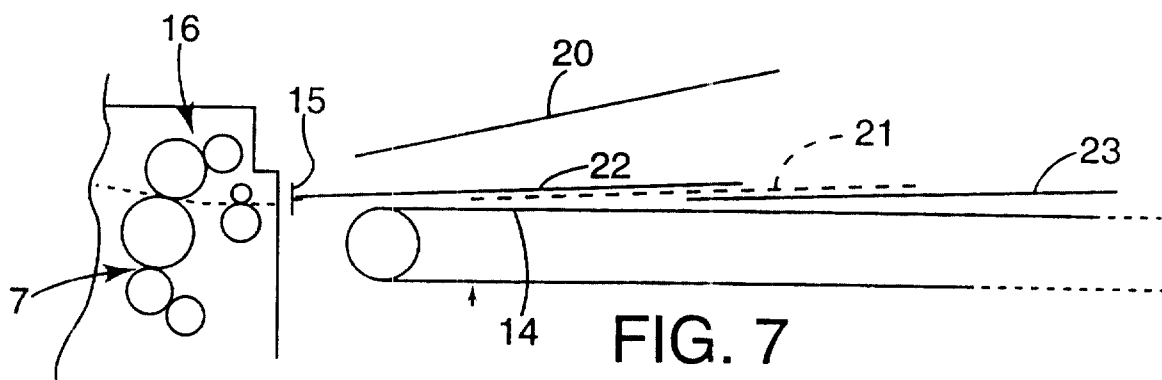
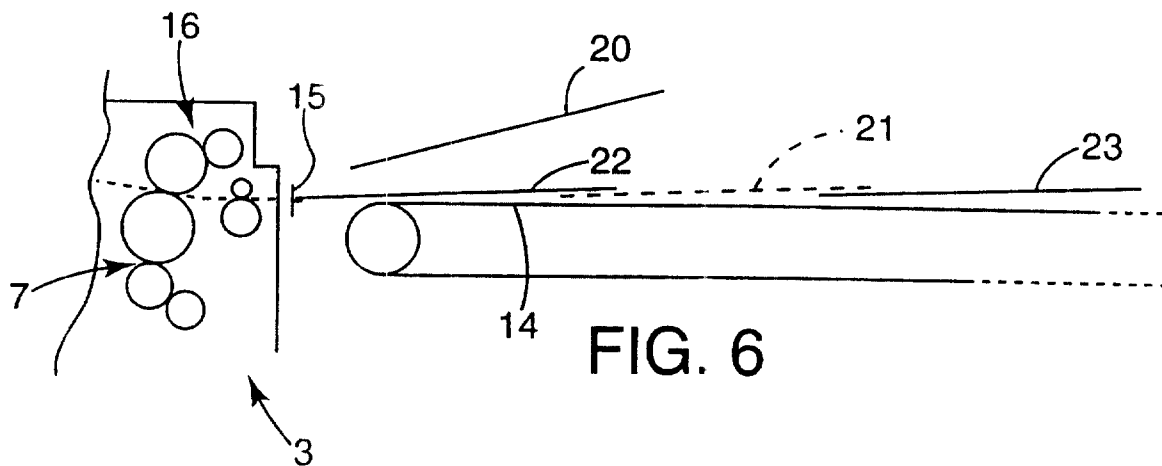

FIG. 4





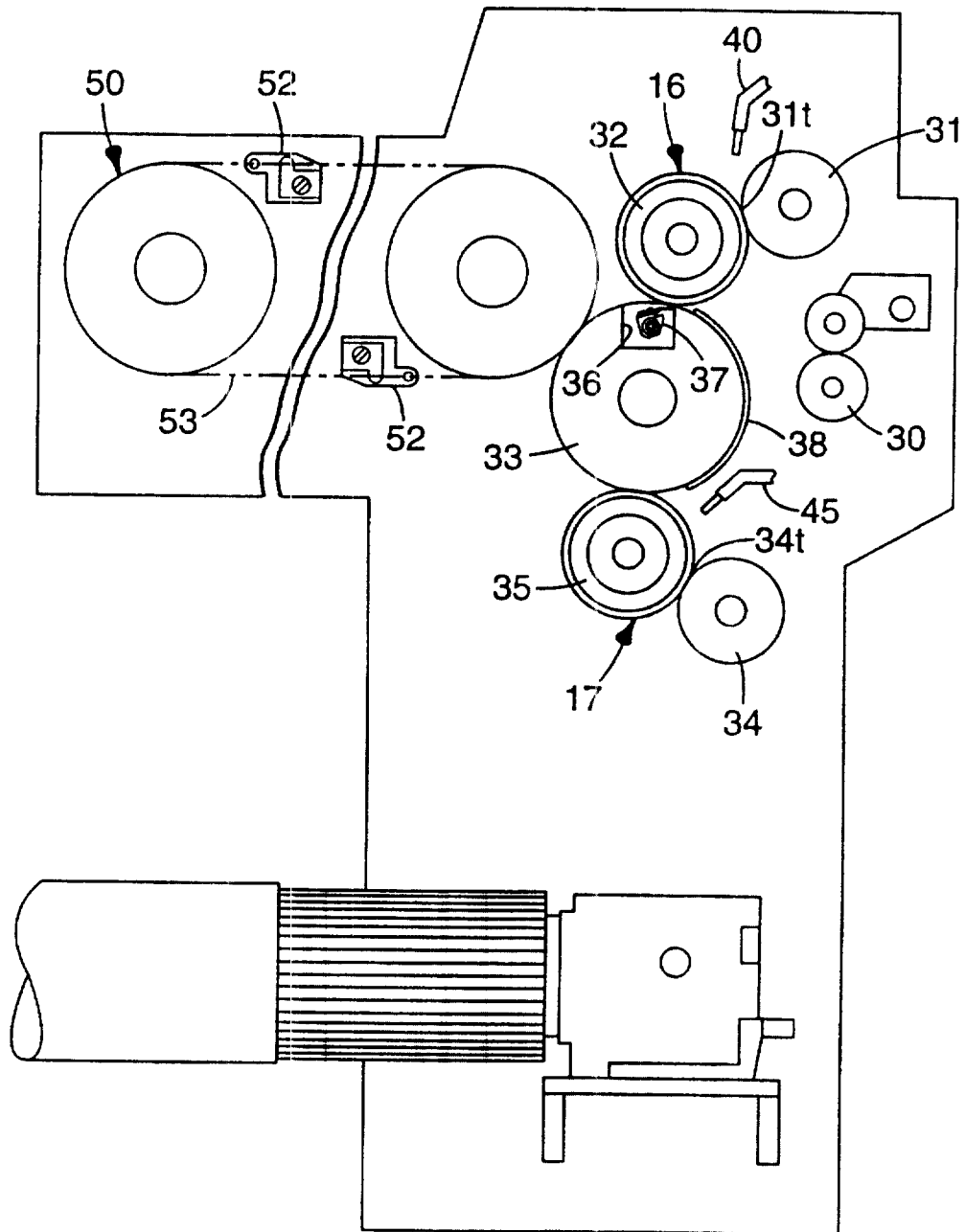

FIG. 9

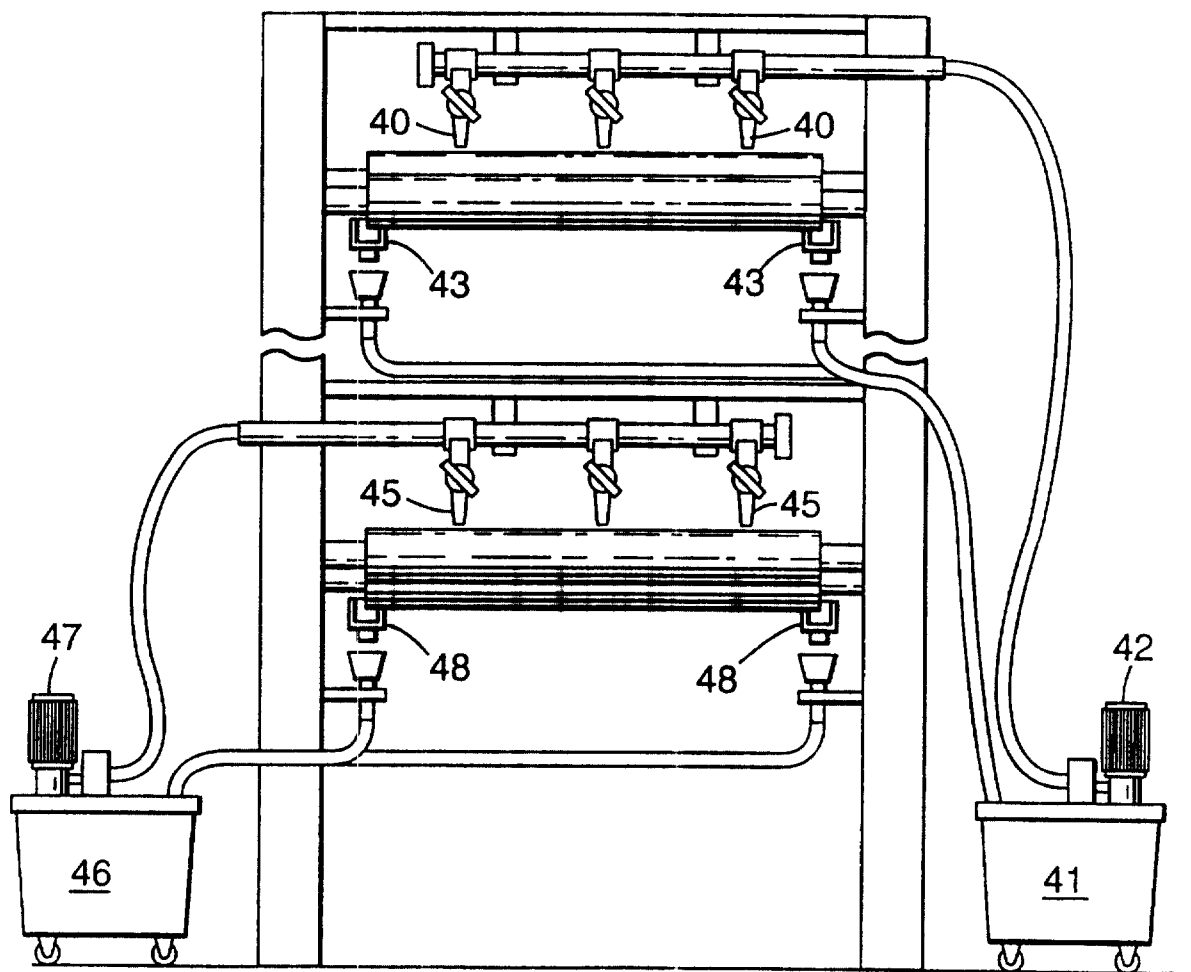

FIG. 10

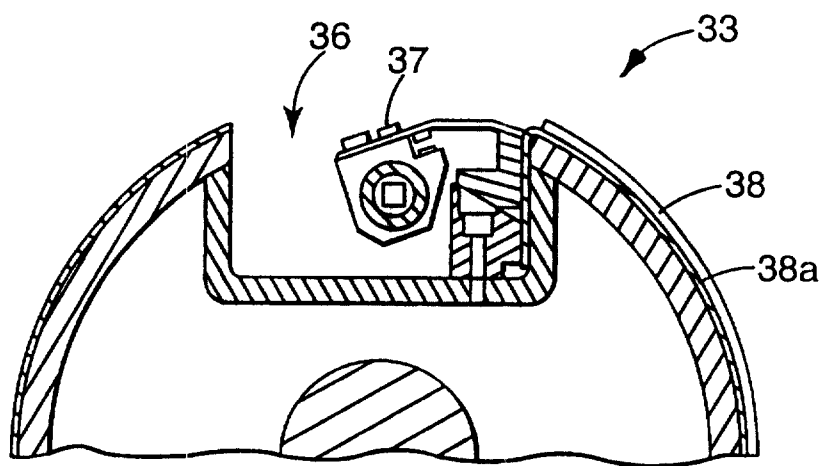

FIG. 11

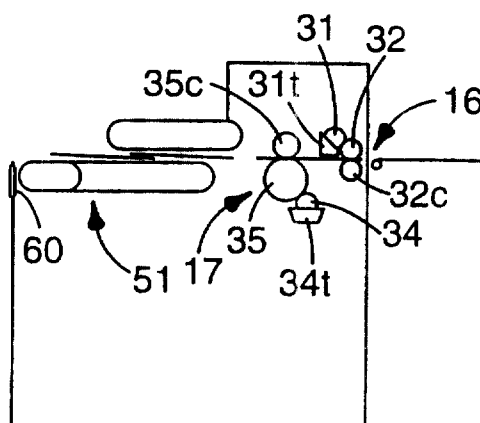

FIG. 12

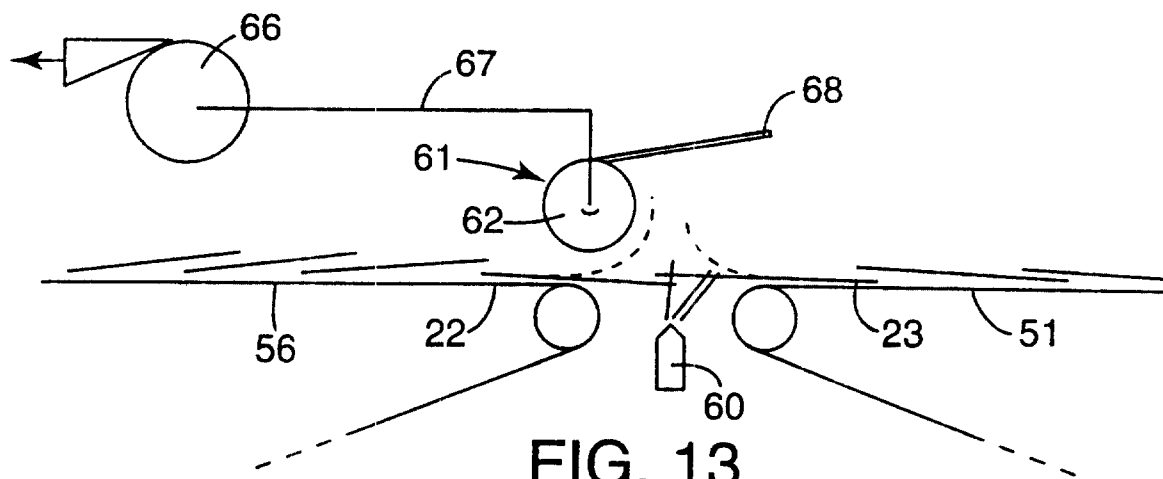

FIG. 13

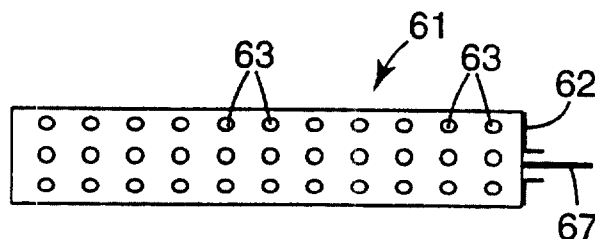

FIG. 14

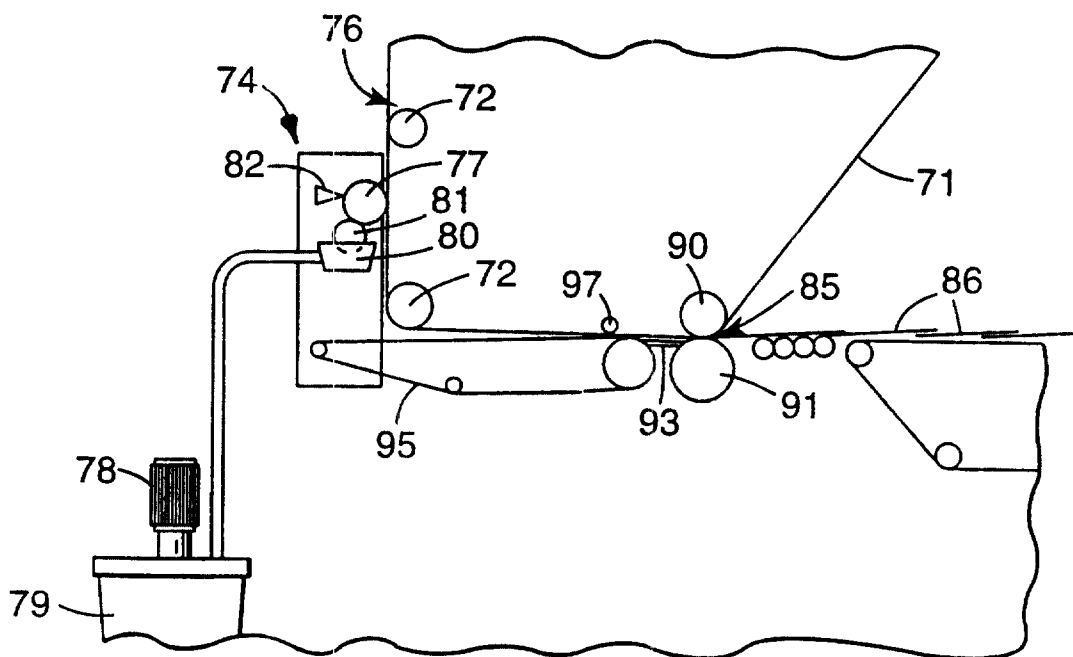

FIG. 15

FIG. 16

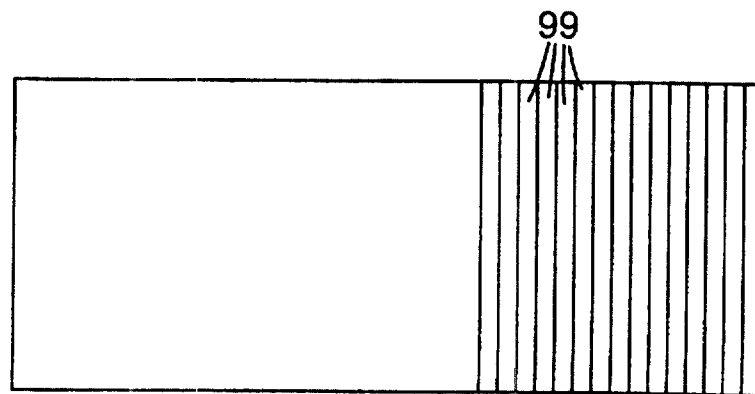
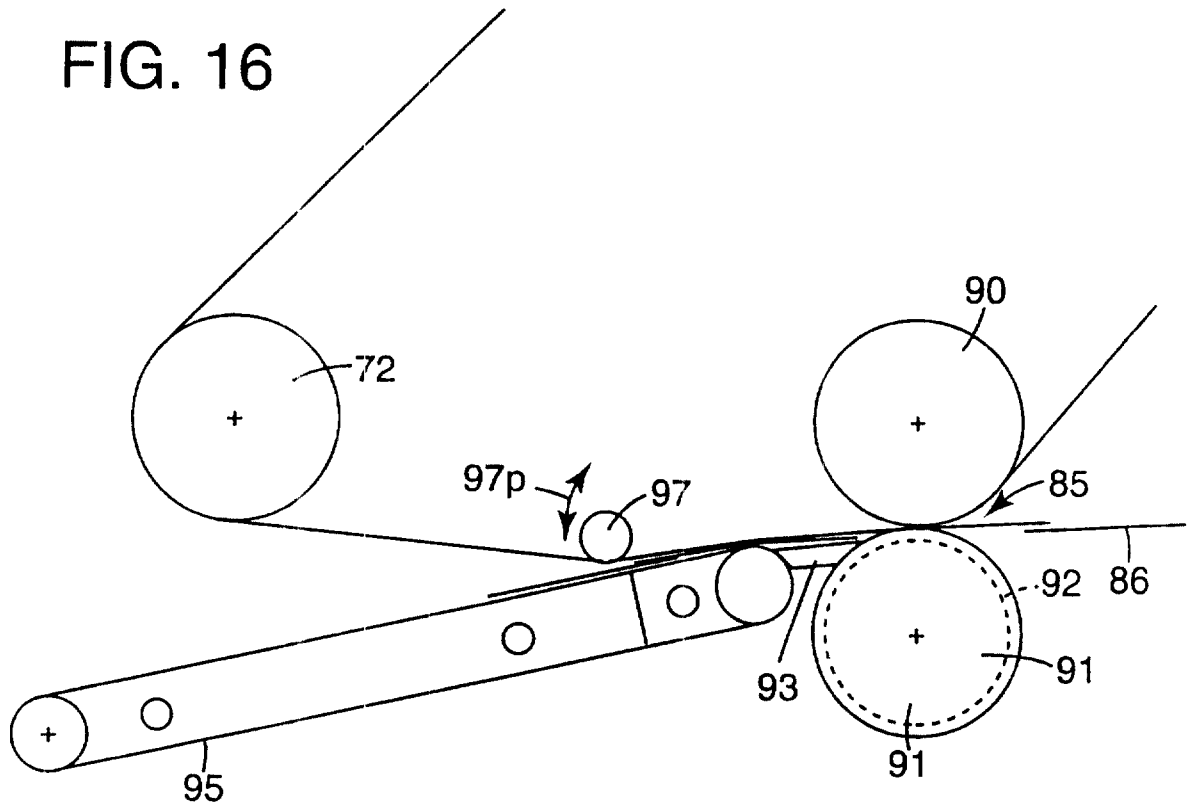

FIG. 19

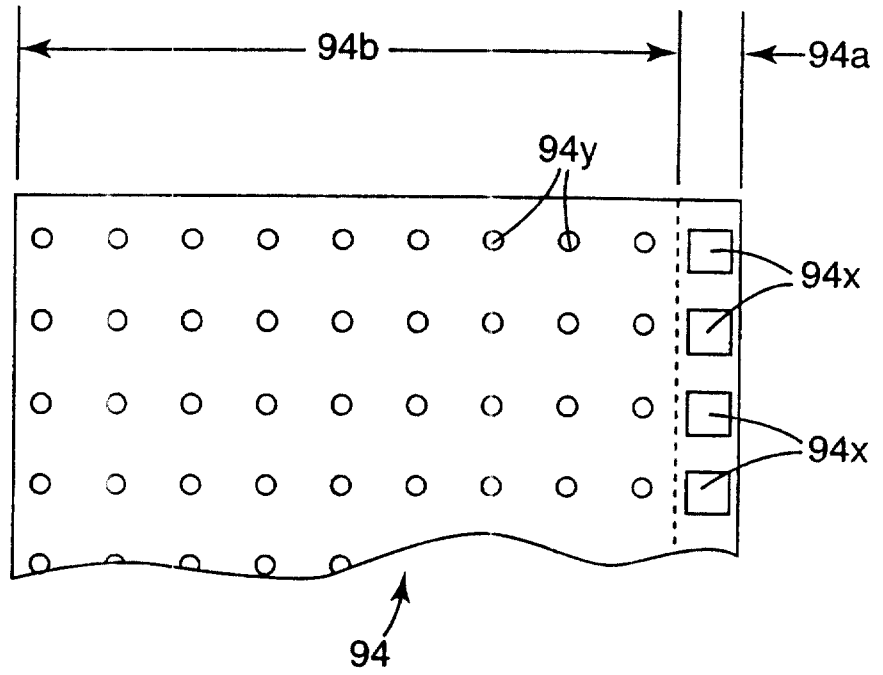

FIG. 17

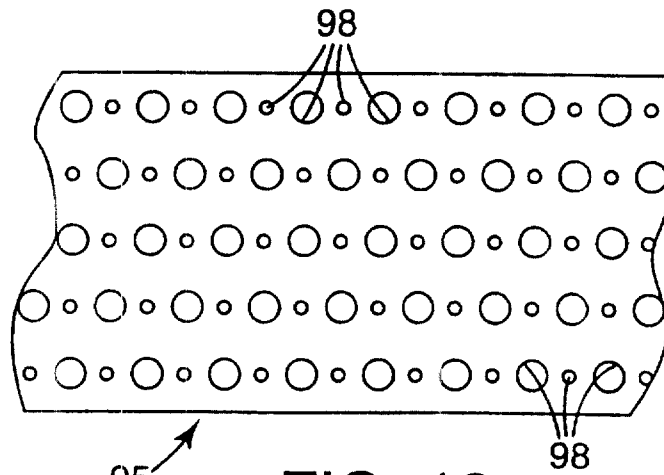

FIG. 18

11/13

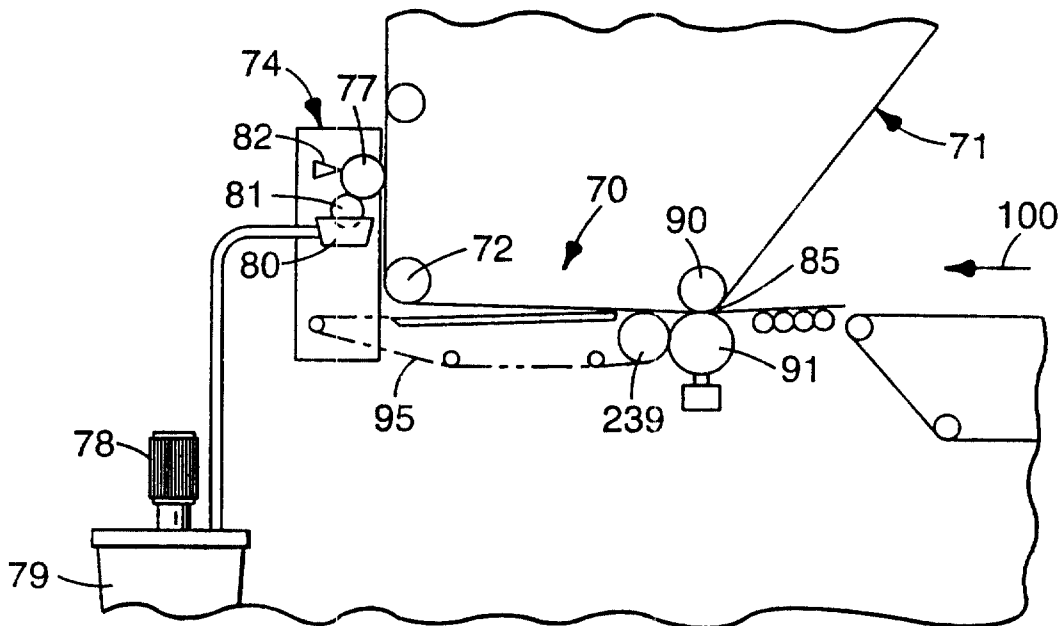

FIG. 21

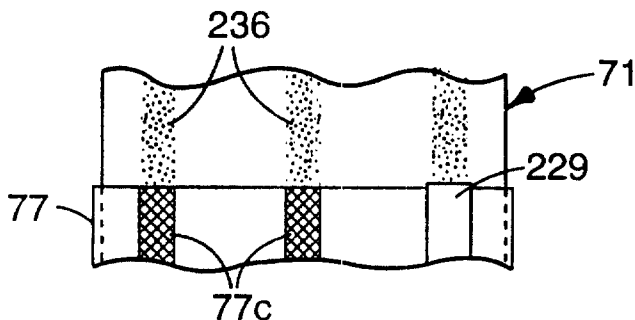

FIG. 22

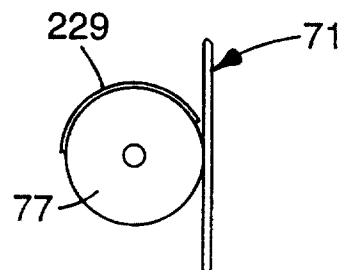

FIG. 23

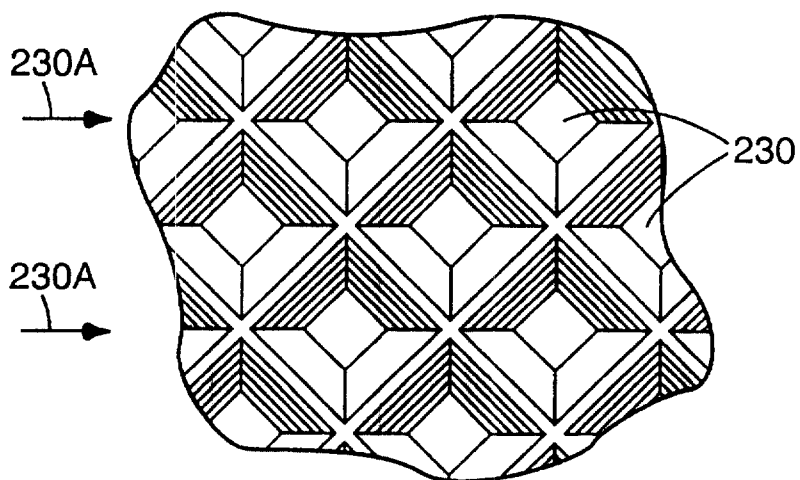

FIG. 24

