



(51) International Patent Classification:

G02B 6/00 (2006.01) G02F 1/065 (2006.01)  
G02B 6/10 (2006.01)

(21) International Application Number:

PCT/US2019/058931

(22) International Filing Date:

30 October 2019 (30.10.2019)

(25) Filing Language:

English

(26) Publication Language:

English

(30) Priority Data:

62/752,838 30 October 2018 (30.10.2018) US

(71) Applicant: **MAGIC LEAP, INC.** [US/US]; 7500 W. Sunrise Blvd., Plantation, Florida 33322 (US).

(72) Inventors: **LI, Ling**; 7500 W. Sunrise Blvd., Plantation, Florida 33322 (US). **CHANG, Chieh**; 7500 W. Sunrise Blvd., Plantation, Florida 33322 (US). **BHAGAT, Sharad D.**; 7500 W. Sunrise Blvd., Plantation, Florida 33322 (US). **PEROZ, Christophe**; 7500 W. Sunrise Blvd., Plantation, Florida 33322 (US). **JONES, William K., Jr.**; 7500 W. Sunrise Blvd., Plantation, Florida 33322 (US). **DENG, Xiaopei**; 7500 W. Sunrise Blvd., Plantation, Florida 33322 (US).

(74) Agent: **FLANAGAN, Heather L.**; Fish & Richardson P.C., P.O. Box 1022, Minneapolis, Minnesota 55440-1022 (US).

(81) Designated States (unless otherwise indicated, for every kind of national protection available): AE, AG, AL, AM, AO, AT, AU, AZ, BA, BB, BG, BH, BN, BR, BW, BY, BZ, CA, CH, CL, CN, CO, CR, CU, CZ, DE, DJ, DK, DM, DO, DZ, EC, EE, EG, ES, FI, GB, GD, GE, GH, GM, GT, HN, HR, HU, ID, IL, IN, IR, IS, JO, JP, KE, KG, KH, KN, KP, KR, KW, KZ, LA, LC, LK, LR, LS, LU, LY, MA, MD, ME, MG, MK, MN, MW, MX, MY, MZ, NA, NG, NI, NO, NZ, OM, PA, PE, PG, PH, PL, PT, QA, RO, RS, RU, RW, SA, SC, SD, SE, SG, SK, SL, SM, ST, SV, SY, TH, TJ, TM, TN, TR, TT, TZ, UA, UG, US, UZ, VC, VN, ZA, ZM, ZW.

(84) Designated States (unless otherwise indicated, for every kind of regional protection available): ARIPO (BW, GH, GM, KE, LR, LS, MW, MZ, NA, RW, SD, SL, ST, SZ, TZ, UG, ZM, ZW), Eurasian (AM, AZ, BY, KG, KZ, RU, TJ, TM), European (AL, AT, BE, BG, CH, CY, CZ, DE, DK, EE, ES, FI, FR, GB, GR, HR, HU, IE, IS, IT, LT, LU, LV, MC, MK, MT, NL, NO, PL, PT, RO, RS, SE, SI, SK, SM, TR), OAPI (BF, BJ, CF, CG, CI, CM, GA, GN, GQ, GW, KM, ML, MR, NE, SN, TD, TG).

(54) Title: POLYMER EYEPIECE ASSEMBLIES FOR AUGMENTED AND MIXED REALITY SYSTEMS

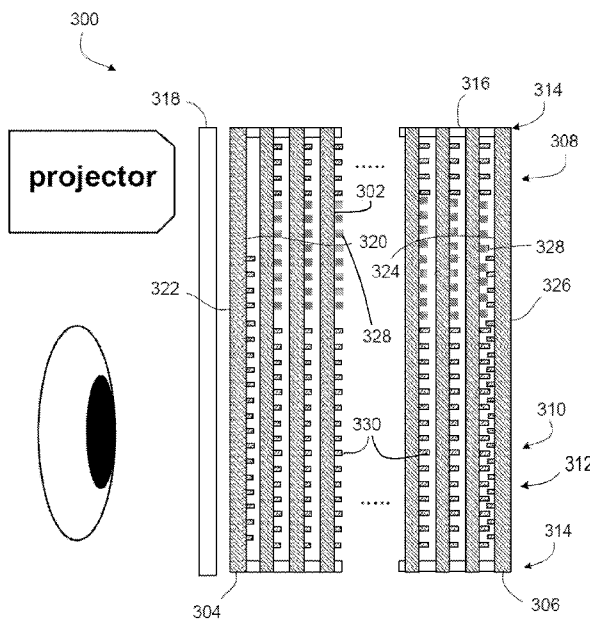


FIG. 3

(57) Abstract: Fabrication of augmented reality (AR) and mixed reality (MR) polymer eyepiece assemblies and the resulting AR/MR polymer eyepiece assemblies may include one or more features, separately or in any appropriate combination, to compensate for expected deformation and to maintain substantially uniform gaps between polymer layers. Such features include fabricating polymer eyepiece assemblies with components having coefficients of thermal expansion (CTE) that are substantially the same; modifying the surface chemistry or structure of one or more polymer layers to increase hydrophobicity or omniphobicity of the polymer layer; disposing adhesive between adjacent polymer layers in continuous and/or extended configurations; and disposing microspheres of different sizes at selected locations between polymer layers.



**Published:**

- *with international search report (Art. 21(3))*
- *before the expiration of the time limit for amending the claims and to be republished in the event of receipt of amendments (Rule 48.2(h))*

**POLYMER EYEPIECE ASSEMBLIES  
FOR AUGMENTED AND MIXED REALITY SYSTEMS**

[0001] This application claims the benefit of U.S. Patent Application No. 62/752,838 entitled “POLYMER EYEPIECE ASSEMBLIES FOR AUGMENTED AND MIXED REALITY SYSTEMS” and filed on October 30, 2018.

**TECHNICAL FIELD**

[0002] This invention is related to polymer eyepiece assemblies for augmented reality (AR) and mixed reality (MR) systems and methods of fabricating the polymer eyepiece assemblies.

**BACKGROUND**

[0003] Eyepiece assemblies for augmented reality (AR) and mixed reality (MR) systems are typically fabricated by stacking multiple layers of glass optical waveguides with an air gap between adjacent layers. FIG. 1 is a side view of glass eyepiece assembly 100 including glass optical waveguides 102 positioned between eye side glass cover 104 and world side glass cover 106. Optical waveguides 102 include various optical features, such as gratings, disposed in or on the waveguides. Light projected through the optical waveguides 102 can interact with the gratings such that the propagation direction of at least a portion of the light is changed. For example, optical waveguides 102 can include an in-coupling grating (ICG) region 108, an orthogonal pupil expander (OPE) region 110, and exit pupil expander (EPE) region 112. Glass optical waveguides 102 and glass covers 104, 106 are typically bonded at edges 114 with an ultraviolet (UV) curable adhesive 116 including silica microspheres of a size selected to achieve a desired spacing between adjacent layers. In some cases, glass eyepiece assembly 100 includes glass lens 118 (e.g., a prescription lens), which may be concave or convex.

[0004] Due at least in part to the low elastic modulus (Young’s modulus) and high coefficient of thermal expansion (CTE) of polymers as compared to glass, parallelism may degrade during fabrication or operation of polymer eyepieces. As depicted in FIG. 2A, first polymer layer 200 may bend (e.g., bow or warp) relative to second polymer layer 202, contributing to non-uniform thickness of a gap, such as air gap 204 between polymer layers 200, 202, across the eyepiece area. Bending of a polymer layer toward (or away from) an adjacent polymer layer typically changes the depth plane of the image exiting the polymer

waveguide layer toward a user's eye. Undesired bending of the polymer waveguide can alter the image perceived by the user and can decrease image quality. As depicted in FIG. 2B, bending of first polymer layer 200 may result in direct contact of first polymer layer 200 and second polymer layer 202 in region 206. Direct contact of adjacent polymer layers can allow leakage of propagating light from one layer into another layer, thereby contributing to deterioration of image quality. Thus, to successfully implement use of polymer layers in some configurations of AR/MR eyepieces, bending of the polymer layers should be reduced or minimized.

### SUMMARY

[0005] In a first general aspect, an eyepiece assembly includes a first cover layer, a second cover layer, and a multiplicity of optical waveguides positioned between the first cover layer and the second cover layer. The first cover layer is adjacent to a first optical waveguide, and the second cover layer is adjacent to a second optical waveguide. An adhesive is between the first cover layer and the first optical waveguide, the second cover layer and the second optical waveguide, and adjacent pairs of optical waveguides. The first cover layer, the second cover layer, and each optical waveguide of the multiplicity of optical waveguides includes a polymer material, and a coefficient of thermal expansion of the polymer material and the adhesive is substantially the same.

[0006] Implementations of the first general aspect may include one or more of the following features.

[0007] The first cover layer, the second cover layer, and the multiplicity of optical waveguides may include the same polymer material. A coefficient of thermal expansion of the polymer material and the adhesive is typically in a range of  $30 \mu\text{m}/\text{m}^\circ\text{C}$  to  $150 \mu\text{m}/\text{m}^\circ\text{C}$  over a temperature interval of about  $-20^\circ\text{C}$  to about  $65^\circ\text{C}$ . The coefficient of thermal expansion of the polymer material and the adhesive is substantially the same over a temperature range of about  $-20^\circ\text{C}$  to about  $65^\circ\text{C}$ . A gap between adjacent pairs of optical waveguides is typically substantially uniform.

[0008] In a second general aspect, an eyepiece assembly includes a first cover layer, a second cover layer, and a multiplicity of optical waveguides positioned between the first cover layer and the second cover layer. A contact angle of water on a surface of the multiplicity of optical waveguides may exceed  $90^\circ$ .

[0009] Implementations of the second general aspect may include one or more of the following features.

[0010] A surface of the multiplicity of optical waveguides typically includes an optically transparent hydrophobic or superhydrophobic coating. The surface of the multiplicity of optical waveguides can be nanopatterned with features having a size, shape, and spacing sufficient to achieve the contact angle of water exceeding 90° on the nanopatterned surface.

[0011] In a third general aspect, a method of fabricating an eyepiece assembly includes treating a surface of a multiplicity of polymer optical waveguides with an optically transparent hydrophobic or superhydrophobic coating to achieve a contact angle of water on the surface of the multiplicity of polymer optical waveguides that exceeds 90°, and assembling the multiplicity of polymer optical waveguides between a first cover layer and a second cover layer.

[0012] Implementations of the third general aspect may include one or more of the following features.

[0013] Treating the surface may include spin-coating, vapor deposition, or dipcoating. The coating may include a perfluorinated polymer, a fluorinated silane, an organically modified silica, or polydimethylsiloxane. A thickness of the coating is typically less than 10 nm or less than 5 nm.

[0014] In a fourth general aspect, a method of fabricating an eyepiece assembly includes forming a multiplicity of polymer optical waveguides with a polymerizable material including a release agent, a dopant, or a combination thereof, and assembling the multiplicity of polymer optical waveguides between a first cover layer and a second cover layer. A contact angle of water on the surface of the multiplicity of polymer optical waveguides exceeds 90°.

[0015] In a fifth general aspect, an eyepiece assembly includes a first cover layer, a second cover layer, and a multiplicity of optical waveguides positioned between the first cover layer and the second cover layer. Each optical waveguide includes at least one grating region on one or more surfaces of the optical waveguide. Grating regions can include an incoupling grating region, an orthogonal pupil expander region, and an exit pupil expander region. The first cover layer is adjacent to a first optical waveguide and the second cover layer is adjacent to a second optical waveguide. The eyepiece assembly includes an adhesive between the first cover layer and the first optical waveguide, between the second cover layer and the second optical waveguide, and between adjacent pairs of optical waveguides. The

adhesive is arranged in one or more extended portions around a perimeter of the grating region.

[0016] Implementations of the fifth general aspect may include one or more of the following features.

[0017] The adhesive is typically not arranged in discrete drops. The eyepiece assembly may include a first additional extended portion of adhesive proximate an interface between the orthogonal pupil expander region and the exit pupil expander region and between the grating region and the adhesive around the perimeter of the grating region. The first additional extended portion of adhesive is typically L-shaped. In some cases, the eyepiece assembly of the fifth general aspect includes a second additional extended portion of adhesive proximate the first additional extended portion of adhesive and between the first additional portion of adhesive and the adhesive around the perimeter of the grating region. The eyepiece assembly of the fifth general aspect may further include an incoupling grating region, and may further include an additional extended portion of adhesive proximate an incoupling grating region and between the incoupling grating region and the adhesive around the perimeter of the grating region.

[0018] In a sixth general aspect, an eyepiece assembly includes a first cover layer, a second cover layer, and a multiplicity of optical waveguides positioned between the first cover layer and the second cover layer. Each optical waveguide has a grating region that can include an orthogonal pupil expander region and an exit pupil expander region. The first cover layer is adjacent to a first optical waveguide and the second cover layer is adjacent to a second optical waveguide. The eyepiece assembly includes an adhesive between the first cover layer and the first optical waveguide, the second cover layer and the second optical waveguide, and adjacent pairs of optical waveguides. The adhesive is arranged around a perimeter of the grating region. First microspheres are positioned in the adhesive arranged around the perimeter of the grating region, and second microspheres are positioned between adjacent optical waveguides in a region between the orthogonal pupil expander region and the exit pupil expander region.

[0019] Implementations of the sixth general aspect may include one or more of the following features.

[0020] In some cases, a diameter of the second microspheres exceeds a diameter of the first microspheres. The eyepiece assembly of the sixth general aspect may further include a first additional extended portion of adhesive proximate an interface between the orthogonal pupil expander region and the exit pupil expander region and between the grating region and

the adhesive around the perimeter of the grating region, and third microspheres positioned in the first additional extended portion of adhesive. A diameter of the third microspheres is between the diameter of the first microspheres and the second microspheres. In some cases, the microspheres include silica.

[0021] Aspects and features in accordance with the present disclosure can include any combination of the aspects and features described herein. That is, aspects and features in accordance with the present disclosure are not limited to the combinations of aspects and features specifically described herein, but also include any combination of the aspects and features provided.

[0022] The details of one or more embodiments of the present disclosure are set forth in the accompanying drawings and the description below. Other features and advantages of the present disclosure will be apparent from the description and drawings, and from the claims.

#### BRIEF DESCRIPTION OF DRAWINGS

[0023] FIG. 1 is a top-down view of an example of a glass eyepiece assembly for an augmented reality (AR) or mixed reality (MR) system.

[0024] FIGS. 2A-2B depict bending of adjacent polymer waveguide layers in a polymer eyepiece assembly.

[0025] FIG. 3 is a top-down view of an example of a polymer eyepiece assembly for an AR/MR system.

[0026] FIG. 4A is a top view of an example of discontinuous placement of adhesive between layers in a glass eyepiece assembly for an AR/MR system. FIG. 4B is a top view of an example of continuous and extended placement of adhesive between layers in a polymer eyepiece assembly.

[0027] FIG. 5A is a front view of an example of microsphere placement between layers in a polymer eyepiece assembly. FIG. 5B is a side view of an example of microsphere placement between layers in a polymer eyepiece assembly.

[0028] FIG. 6 shows a contour plot of air gap distribution between a world side cover and an adjacent polymer waveguide in a polymer eyepiece assembly.

#### DETAILED DESCRIPTION

[0029] Aspects of the present disclosure are directed toward methods of fabricating polymer augmented reality (AR) and mixed reality (MR) eyepiece assemblies to improve parallelism and thus optical performance, as well as the resulting improved AR/MR polymer

eyepiece assemblies. Fabrication of AR/MR polymer eyepiece assemblies and the resulting AR/MR polymer eyepiece assemblies may include one or more aspects described herein, separately or in any appropriate combination, to compensate for expected deformation and to maintain substantially uniform gaps between polymer layers. Various aspects include fabricating polymer eyepiece assemblies with components having coefficients of thermal expansion (CTE) that are substantially the same; modifying the surface chemistry or structure of one or more polymer layers to increase the hydrophobicity or omniphobicity; disposing adhesive between adjacent polymer layers in continuous and/or extended configurations; and disposing microspheres of different sizes at selected locations between polymer layers. As used herein, an “adjacent layers” refers to layers that are directly adjacent, such that there are no intervening eyepiece layers between two adjacent layers.

[0030] In a first aspect, optical waveguides, covers, and adhesive of an eyepiece assembly are fabricated with a material having the same or substantially the same CTE (e.g., about  $60 \mu\text{m}/\text{m}^\circ\text{C}$  between about  $0^\circ\text{C}$  and about  $40^\circ\text{C}$  and about  $100 \mu\text{m}/\text{m}^\circ\text{C}$  between about  $40^\circ\text{C}$  and about  $60^\circ\text{C}$ , or between about  $30 \mu\text{m}/\text{m}^\circ\text{C}$  and about  $150 \mu\text{m}/\text{m}^\circ\text{C}$  in a temperature range of about  $-20^\circ\text{C}$  to about  $65^\circ\text{C}$ ). FIG. 3 depicts polymer eyepiece assembly 300 including polymer optical waveguides 302 positioned between eye side polymer cover 304 and world side polymer cover 306. Polymer eyepiece assembly 300 includes a multiplicity of (e.g., 3, 4, 5, 6, 7, 8, 9, 10, or more) polymer optical waveguides 302. Polymer optical waveguides 302 and polymer covers 304, 306 typically have a thickness in a range of about  $300 \mu\text{m}$  to about  $1000 \mu\text{m}$ . Polymer optical waveguides 302 can include one or more grating regions, such as in-coupling grating (ICG) region 308, orthogonal pupil expander (OPE) region 310, and exit pupil expander (EPE) region 312. Polymer optical waveguides 302 and polymer covers 304, 306 are typically bonded at edges 314 with an ultraviolet (UV) curable adhesive 316 including silica microspheres of a size selected to achieve a desired spacing between adjacent layers. In some cases, polymer eyepiece assembly 300 includes polymer lens 318 (e.g., a prescription lens) which may be concave or convex. A substantially constant air gap of about  $10 \mu\text{m}$  to about  $500 \mu\text{m}$  between adjacent components (e.g., between a polymer cover and an adjacent polymer optical waveguide, or between two adjacent polymer optical waveguides) can be selected by combining microspheres of a selected size with the adhesive, or positioning the microspheres mechanically during fabrication. As used herein, “substantially constant” refers to  $\pm 10 \mu\text{m}$  or  $\pm 15 \mu\text{m}$ .

[0031] Polymer optical waveguides 302 are typically fabricated of a polymer material having a selected CTE (e.g., a CTE in a range of  $30 \mu\text{m}/\text{m}^\circ\text{C}$  and  $150 \mu\text{m}/\text{m}^\circ\text{C}$  in a

temperature range of  $-20^{\circ}\text{C}$  to  $65^{\circ}\text{C}$ ). Suitable polymer materials include thiolene-based polymers, polycarbonate, polymethyl methacrylate (PMMA), polyetherimide, cyclic olefin polymers and copolymers, polystyrene, acrylic copolymers, and polyamide. Other suitable polymer materials include MR-7, MR-8, and MR-10 (available from Mitsui Chemicals), CR-39 (available from PPG Industries), and ORMOSTAMP (available from micro resist technologies GmbH). In some implementations, polymer covers 304, 306 are fabricated of the same polymer material used to fabricate polymer optical waveguides 302. In certain implementations, polymer covers 304, 306 are fabricated of a different polymer material than that used to fabricate polymer optical waveguides 302, but having a CTE substantially the same as that of the polymer optical waveguides (e.g., in a range of  $30\ \mu\text{m}/\text{m}^{\circ}\text{C}$  to  $150\ \mu\text{m}/\text{m}^{\circ}\text{C}$  over a temperature range of  $-20^{\circ}\text{C}$  to  $65^{\circ}\text{C}$ ). Adhesive 316 has a CTE substantially the same as that of the polymer used to fabricate polymer optical waveguides 302 and polymer covers 304, 306. One example of a suitable adhesive is DYMAX OP-4 Optical Adhesive (available from Dymax Corporation). Polymer lens 318 also has a CTE that is the same or substantially the same as that of the polymer used to fabricate polymer optical waveguides 302 and polymer covers 304, 306. Because polymer optical waveguides 302, polymer covers 304, 306, and adhesive 316 have a CTE that is the same or substantially the same, bending (e.g., bowing and warping) that occurs during fabrication (e.g., stacking of layers) and operation (e.g., thermal cycling) is reduced or minimized at least in part because the materials are able to expand and contract in a substantially similar amount, thereby reducing or minimizing variations in the air gap between adjacent layers.

[0032] In a second aspect, one or more of polymer optical waveguides 302, polymer covers 304, 306, and polymer lens 318 is altered (e.g., chemically or structurally) to increase the hydrophobicity or omniphobicity of the surface such that a contact angle of water on the surface exceeds  $90^{\circ}$ . Increasing a hydrophobicity or omniphobicity of adjacent surfaces promotes repulsion of the adjacent surfaces, thereby inhibiting contact of adjacent layers.

[0033] One example of structural alteration to increase hydrophobicity or omniphobicity includes providing additional nanopatterns to inside surface 320, outside surface 322, or both of eye side cover layer 304, inside surface 324, outside surface 326, or both of world side cover layer 306, or any combination thereof, to reduce the available contact area, such that the altered cover layer repels adjacent polymer optical waveguide 302. The additional nanopatterns are sized and positioned to achieve a "lotus effect" and so as not to interfere with or modify light interacting with the ICG region 308, the OPE region 310, or the EPE region 312. The increased hydrophobicity or omniphobicity of cover layers 304, 306 can

reduce any sticking between the cover layers 304, 306 and adjacent polymer optical waveguides 302. Thus, even if the polymer layers and/or cover layers bow, warp, or bend to such an extent that they come into contact with each other, the hydrophobic surfaces created by nanopatterns reduce the ability of the layers to stick to each other. This promotes a uniform gap between the layers.

[0034] Another example of structural alteration includes providing additional nanopatterns 328 to polymer optical waveguides 302 to areas outside the light propagating path. Additional nanopatterns 328 can extend from the surface of polymer optical waveguides 302 up to about 50 nm further than the light propagation gratings 330 (including grating features located in ICG region 308, OPE region 310, and EPE region 312), thereby effectively repelling (without contacting) adjacent layers. Additional nanopatterns 328 (e.g., on polymer cover layers 304, 306, on polymer optical waveguides 302, or both) can be implemented to achieve the effect of an antireflective coating. Additional nanopatterns 328 are sized and positioned to achieve a “lotus effect” and so as not to interfere with or modify light interacting with the ICG region 308, the OPE region 310, or the EPE region 312, as described above with respect to the nanopatterns disposed on cover layers 304, 306.

[0035] One example of chemical alteration to increase hydrophobicity or omniphobicity includes treating a surface of polymer optical waveguide 302, polymer covers 304, 306, or any combination thereof, with an optically transparent hydrophobic and/or superhydrophobic coating to reduce a surface energy of a blank (i.e., non-patterned) portion of the surface. Treating the surface to form a hydrophobic or omniphobic coating may include aging the surface with water or heat (e.g., 40°C-60°C for at least one week) or forming a thin film (e.g., less than 10 nm or less than 5 nm) of a fluorine- or silicon-containing compound (e.g., TEFLON, polydimethylsiloxane, fluorinated silane, or organically modified silica nano-coating) on the surface. The coating may be applied by spin-coating, vapor deposition, dip coating, or other appropriate method. The anti-sticking property of a surface of the polymer optical waveguide can also be enhanced by combining a release agent or appropriate dopant in the polymerizable material used to fabricate the polymer optical waveguide. A concentration of the release agent may be selected to avoid negative impact on the refractive index and other optical properties of the resulting polymer.

[0036] In a third aspect, an adhesive is disposed on a first polymer layer (e.g., a polymer cover or a polymer optical waveguide) in such a way as to adhere the first polymer layer to a second polymer layer (e.g., a polymer optical waveguide or a polymer cover) more closely to the center of the eyepiece without interfering with the optical properties of the eyepiece. The

adhesive may be applied in a continuous or extended configuration instead of in discrete drops. FIG. 4A depicts an example in which adhesive is disposed on polymer layer 400 as discrete drops 402. In contrast, FIG. 4B depicts an example in which adhesive is disposed on polymer layer 400 as continuous portion of adhesive 404 rather than as discrete drops. Continuous portion of adhesive 404 is disposed around a perimeter of polymer optical waveguide 400 including OPE 406 and EPE 408 with ICG 410. Reinforcing portions of adhesive are disposed proximate OPE 406, EPE 408, and ICG 410. Specifically, reinforcing portion of adhesive 414 is disposed proximate ICG 410, and reinforcing L-shaped portions 412 are disposed proximate the interface of ICG 410, OPE 406, and EPE 408. Reinforcing adhesive portions, disposed closer to a center area of the eyepiece, provide additional support to polymer layer 400 and help maintain a uniform air gap between the adjacent layers. Other patterns of reinforcing portions can also be implemented to provide additional support to adhered polymeric layers.

[0037] In a fourth aspect, microspheres of selected sizes (e.g., 10  $\mu\text{m}$  to 200  $\mu\text{m}$  in diameter) are disposed on various regions across a polymer layer of a polymer eyepiece assembly to help maintain a uniform air gap between polymer layers (e.g., between a polymer cover and a polymer optical waveguide or between two polymer optical waveguides). The microspheres may be made of silica or other appropriate material. Examples of suitable microspheres include glass spheres available from Cospheric. Microsphere size and regions in which microspheres are disposed are selected such that the microspheres compensate for any expected deformation of the polymer layers during fabrication and operation (e.g., during thermal cycles at temperatures up to 65°C). Hence, larger microspheres may be selected for a region in which the deformation is expected to be larger, and smaller microspheres may be selected for a region in which the deformation is expected to be smaller. Microsphere size is also selected to be small enough such that the microspheres do not interfere with light propagation. In some cases, a filler with suitable optical properties (e.g., an aerogel) may be disposed between adjacent polymer layers.

[0038] FIG. 5A is a top view of polymer optical waveguide 500, with adhesive portion 502 applied in a continuous configuration around a perimeter of the polymer optical waveguide. Adhesive portion 504 is applied in an extended configuration. Small microspheres 506 are disposed in adhesive portion 502 and medium microspheres 508 are disposed in adhesive portion 504. Large microspheres 510 can be placed between OPE 512 and EPE 514. Large microspheres 510 are depicted in a single row orthogonal to plane X-X for ease of illustration. In some cases, however, the microspheres are disposed in a region but

not necessarily in rows, and there may be more than one microsphere in the cross section of polymer optical waveguide 500 along plane X-X of FIG. 5A. FIG. 5B is a cross-sectional view through plane X-X of FIG. 5A, showing polymer optical waveguide 500, adjacent polymer optical waveguide 516, small microspheres 506, and large microspheres 510. In FIG. 5B, large microspheres 510 are depicted as disposed in three rows extending parallel to plane X-X of FIG. 5A.

[0039] FIG. 6 shows a contour plot of a calculated air gap distribution (units in microns) between a polymer world side cover and a first polymer optical waveguide during operation in an ambient environment in the absence of any corrective features described in this disclosure. A temperature of the eyepiece assembly ranges from about 40°C to about 55°C. Implementation of any one or more of the described corrective features would decrease the air gap depicted in FIG. 6.

[0040] Only a few implementations are described and illustrated. Variations, enhancements and improvements of the described implementations and other implementations can be made based on what is described and illustrated in this document.

## WHAT IS CLAIMED IS:

1. An eyepiece assembly comprising:
  - a first cover layer;
  - a second cover layer;
  - a multiplicity of optical waveguides positioned between the first cover layer and the second cover layer, wherein the first cover layer is adjacent to a first optical waveguide and the second cover layer is adjacent to a second optical waveguide; and
  - an adhesive between:
    - the first cover layer and the first optical waveguide,
    - the second cover layer and the second optical waveguide, and
    - adjacent pairs of optical waveguides;

wherein the first cover layer, the second cover layer, and each optical waveguide of the multiplicity of optical waveguides comprises a polymer material, and a coefficient of thermal expansion of the polymer material and the adhesive is substantially the same.
2. The eyepiece assembly of claim 1, wherein the first cover layer, the second cover layer, and the multiplicity of optical waveguides comprise the same polymer material.
3. The eyepiece assembly of claim 1, wherein the coefficient of thermal expansion of the polymer material and the adhesive is in a range of  $30 \mu\text{m}/\text{m}^\circ\text{C}$  to  $150 \mu\text{m}/\text{m}^\circ\text{C}$ .
4. The eyepiece assembly of claim 1, wherein the coefficient of thermal expansion of the polymer material and the adhesive is substantially the same over a temperature range of about  $20^\circ\text{C}$  to about  $65^\circ\text{C}$ .
5. The eyepiece assembly of claim 1, wherein a gap between adjacent pairs of optical waveguides is substantially uniform.
6. An eyepiece assembly comprising:
  - a first cover layer;
  - a second cover layer; and
  - a multiplicity of optical waveguides positioned between the first cover layer and the second cover layer;

wherein a contact angle of water on a surface of the multiplicity of optical waveguides exceeds 90°.

7. The eyepiece assembly of claim 6, wherein the surface of the multiplicity of optical waveguides comprises an optically transparent hydrophobic or superhydrophobic coating.
8. The eyepiece assembly of claim 6, wherein the surface of the multiplicity of optical waveguides is nanopatterned with features having a size, shape, and spacing sufficient to achieve the contact angle of water exceeding 90° on the nanopatterned surface.
9. A method of fabricating an eyepiece assembly, the method comprising  
treating a surface of a multiplicity of polymer optical waveguides with an optically transparent hydrophobic or superhydrophobic coating to achieve a contact angle of water on the surface of the multiplicity of polymer optical waveguides that exceeds 90°; and  
assembling the multiplicity of polymer optical waveguides between a first cover layer and a second cover layer.
10. The method of claim 9, wherein treating the surface comprises spin-coating, vapor deposition, or dipcoating.
11. The method of claim 9, wherein the coating comprises a perfluorinated polymer, a fluorinated silane, an organically modified silica, or polydimethylsiloxane.
12. The method of claim 9, wherein a thickness of the coating is less than 10 nm.
13. The method of claim 12, wherein the thickness of the coating is less than 5 nm.
14. A method of fabricating an eyepiece assembly, the method comprising:  
forming a multiplicity of polymer optical waveguides with a polymerizable material comprising a release agent, a dopant, or a combination thereof, wherein a contact angle of water on the surface of the multiplicity of polymer optical waveguides hat exceeds 90°; and  
assembling the multiplicity of polymer optical waveguides between a first cover layer and a second cover layer.

15. An eyepiece assembly comprising:
  - a first cover layer;
  - a second cover layer;
  - a multiplicity of optical waveguides positioned between the first cover layer and the second cover layer, each optical waveguide comprising a grating region comprising an orthogonal pupil expander region and an exit pupil expander region, wherein the first cover layer is adjacent to a first optical waveguide and the second cover layer is adjacent to a second optical waveguide; and
  - an adhesive between:
    - the first cover layer and the first optical waveguide,
    - the second cover layer and the second optical waveguide, and
    - adjacent pairs of optical waveguides;

wherein the adhesive is arranged in one or more extended portions around a perimeter of the grating region.
16. The eyepiece assembly of claim 15, wherein the adhesive is not arranged in discrete drops.
17. The eyepiece assembly of claim 15, further comprising a first additional extended portion of adhesive proximate an interface between the orthogonal pupil expander region and the exit pupil expander region and between the grating region and the adhesive around the perimeter of the grating region.
18. The eyepiece assembly of claim 17, wherein the first additional extended portion of adhesive is L-shaped.
19. The eyepiece assembly of claim 17, further comprising a second additional extended portion of adhesive proximate first additional extended portion of adhesive and between the first additional portion of adhesive and the adhesive around the perimeter of the grating region.
20. The eyepiece assembly of claim 15, further comprising an incoupling grating region, and further comprising an additional extended portion of adhesive proximate the incoupling

grating region and between the incoupling grating region and the adhesive around the perimeter of the grating region.

21. An eyepiece assembly comprising:
  - a first cover layer;
  - a second cover layer;
  - a multiplicity of optical waveguides positioned between the first cover layer and the second cover layer, each optical waveguide comprising a grating region comprising an orthogonal pupil expander region and an exit pupil expander region, wherein the first cover layer is adjacent to a first optical waveguide and the second cover layer is adjacent to a second optical waveguide;
  - an adhesive between:
    - the first cover layer and the first optical waveguide,
    - the second cover layer and the second optical waveguide, and
    - adjacent pairs of optical waveguides,wherein the adhesive is arranged around a perimeter of the grating region;
  - first microspheres positioned in the adhesive arranged around the perimeter of the grating region; and
  - second microspheres positioned between adjacent optical waveguides in a region between the orthogonal pupil expander region and the exit pupil expander region.
22. The eyepiece assembly of claim 21, wherein a diameter of the second microspheres exceeds a diameter of the first microspheres.
23. The eyepiece assembly of claim 21, further comprising:
  - a first additional extended portion of adhesive proximate an interface between the orthogonal pupil expander region and the exit pupil expander region and between the grating region and the adhesive around the perimeter of the grating region; and
  - third microspheres positioned in the first additional extended portion of adhesive.
24. The eyepiece assembly of claim 23, wherein a diameter of the third microspheres is between the diameter of the first microspheres and the second microspheres.
25. The eyepiece assembly of claim 21, wherein the microspheres comprise silica.

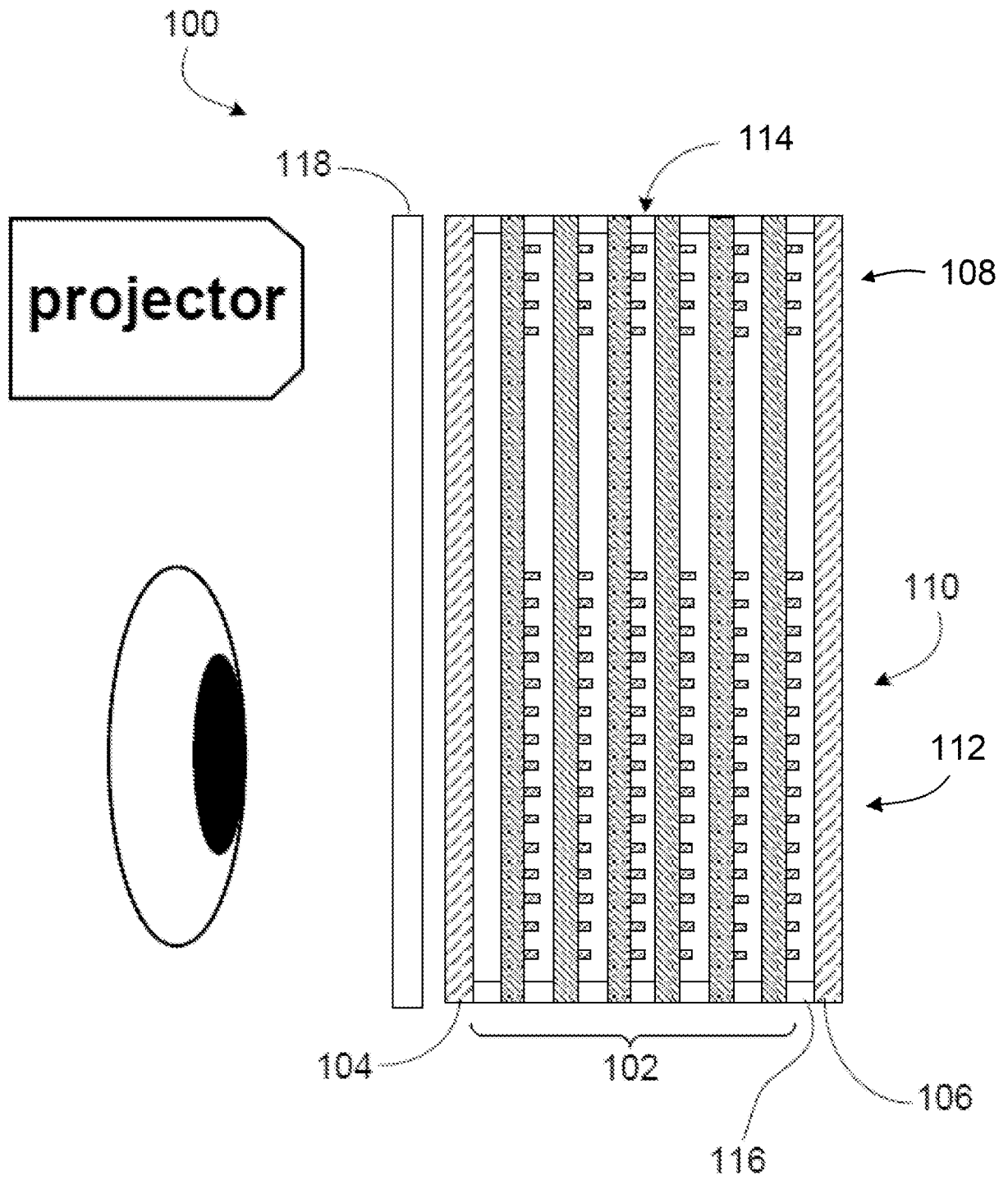
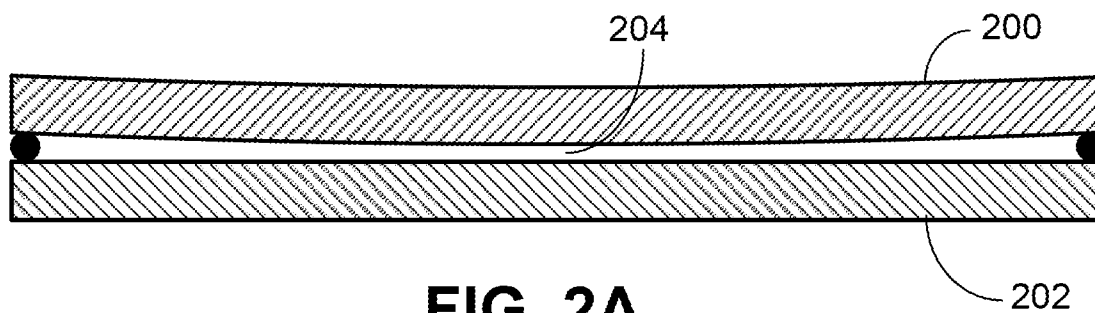
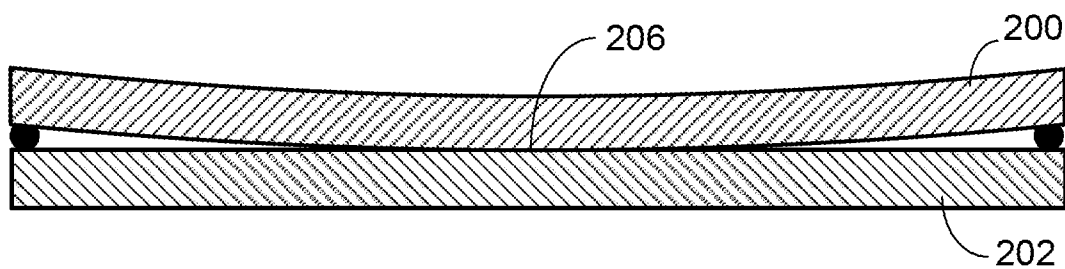


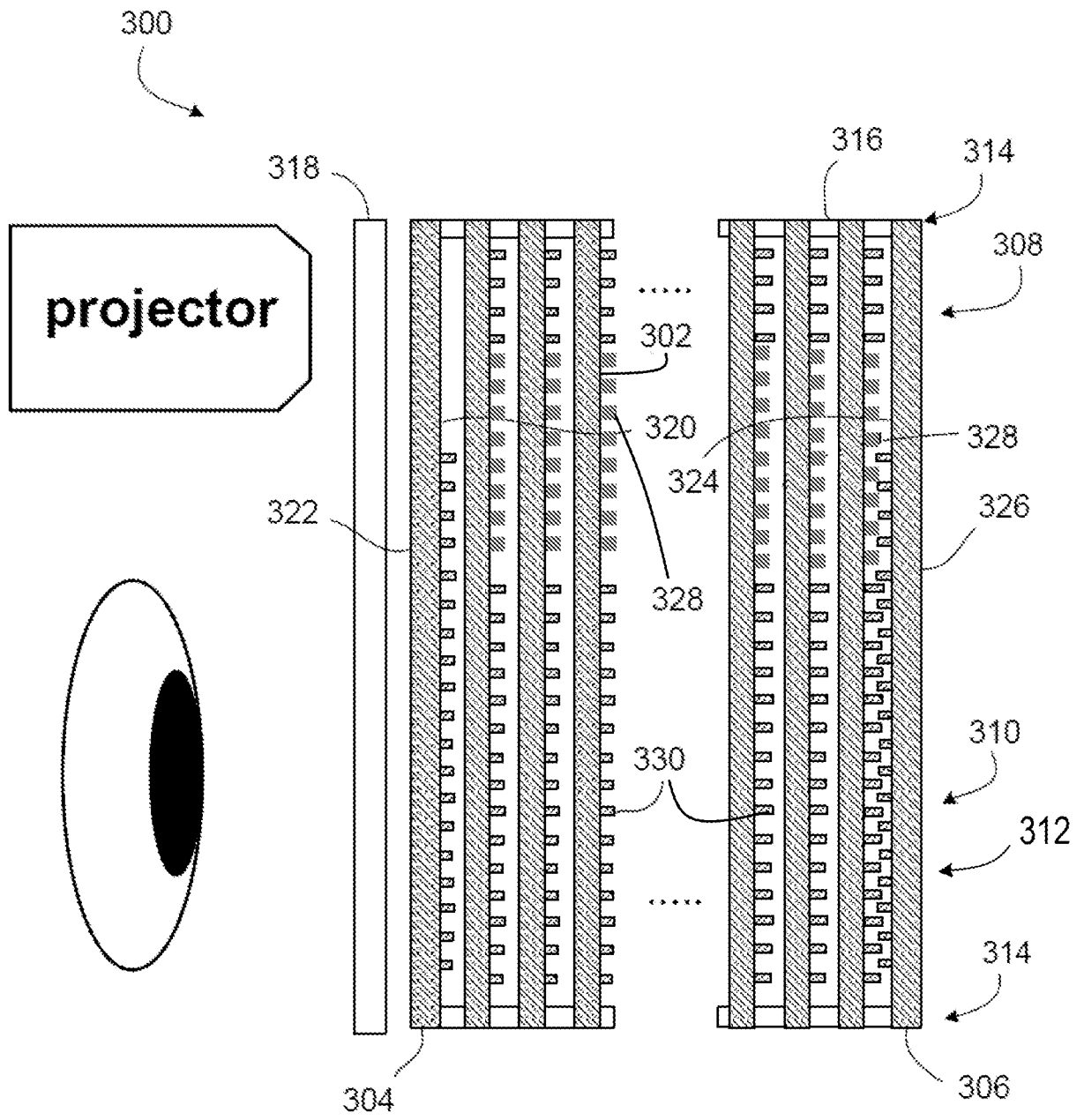
FIG. 1



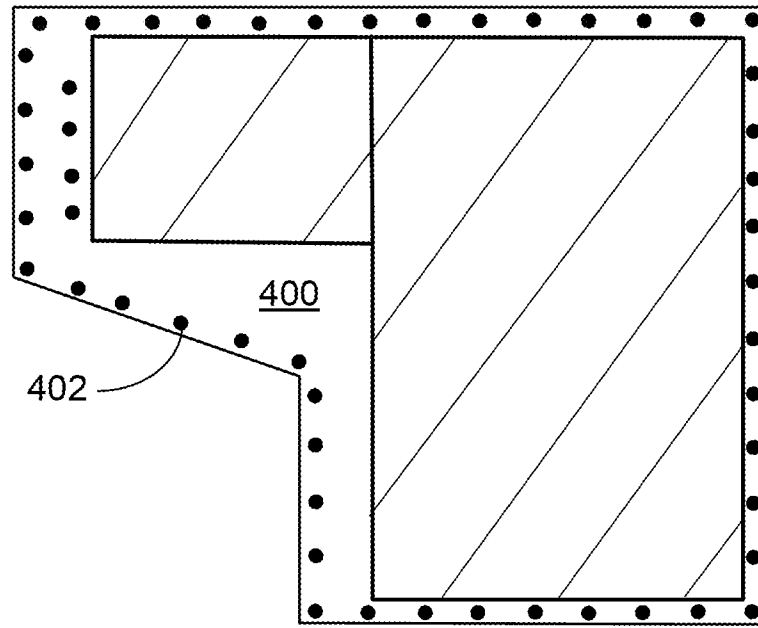
**FIG. 2A**



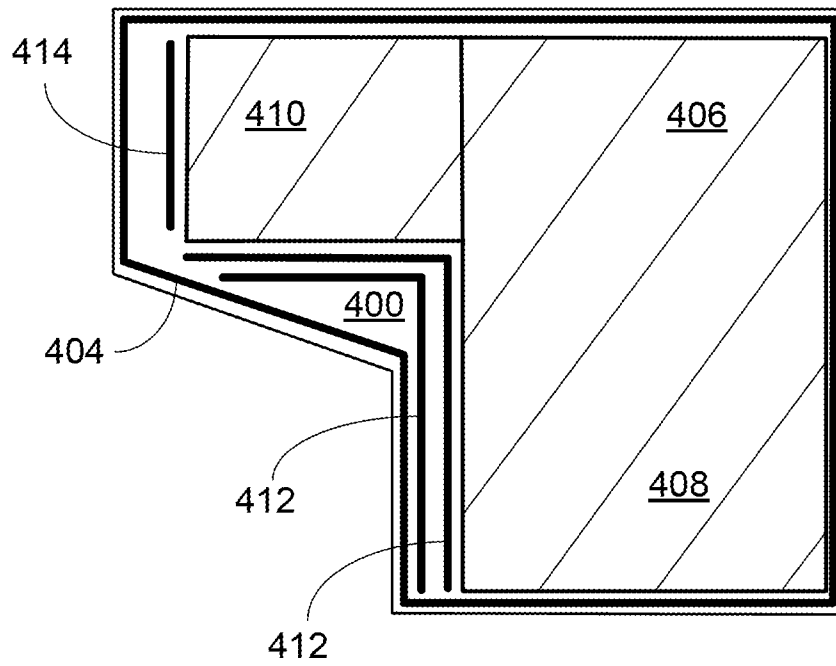
**FIG. 2B**



**FIG. 3**

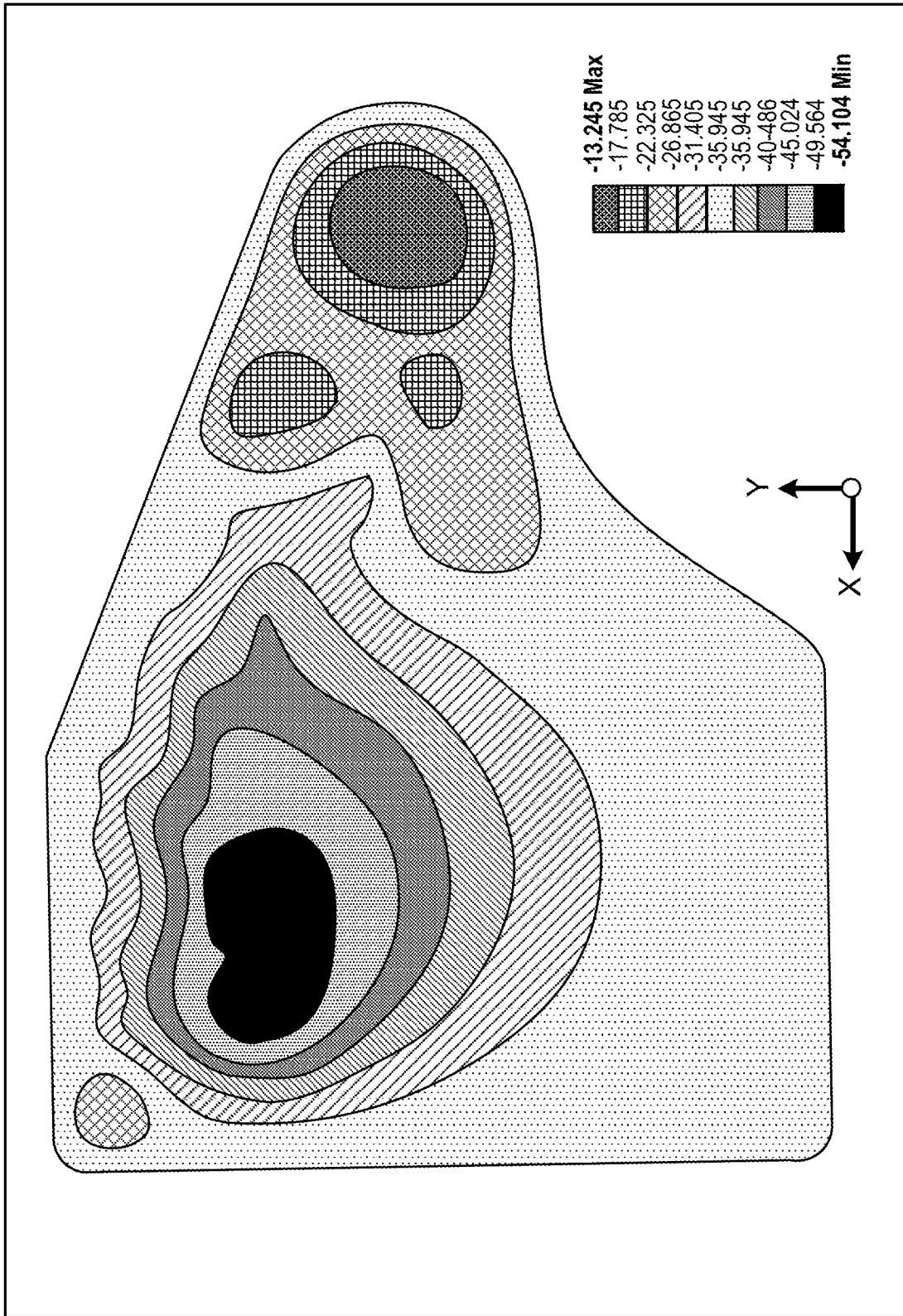


**FIG. 4A**



**FIG. 4B**





**FIG. 6**

## INTERNATIONAL SEARCH REPORT

International application No.

PCT/US 19/58931

## A. CLASSIFICATION OF SUBJECT MATTER

IPC - G02B 6/00; G02B 6/10; G02F 1/065 (2020.01)

CPC - G02B 6/0025; G02B 6/0026; G02B 6/004; G02B 6/0051; G02B 6/0065; G02B 6/0076; G02B 6/0095; G02B 6/02209; G02F 1/377; G02F 1/3551; G02F 1/355

According to International Patent Classification (IPC) or to both national classification and IPC

## B. FIELDS SEARCHED

Minimum documentation searched (classification system followed by classification symbols)

See Search History document

Documentation searched other than minimum documentation to the extent that such documents are included in the fields searched

See Search History document

Electronic data base consulted during the international search (name of data base and, where practicable, search terms used)

See Search History document

## C. DOCUMENTS CONSIDERED TO BE RELEVANT

Category*	Citation of document, with indication, where appropriate, of the relevant passages	Relevant to claim No.
Y	US 2018/0231771 A1 (MAGIC LEAP, INC.) 16 August 2018 (16.08.2018), para [0118], [0120], [0123]-[0124],	1-5
Y	US 2017/0363795 A1 (CREE, INC.) 21 December 2017 (21.12.2017), para [0038], [0050], [0058]	1-5
A	US 2018/0059320 A1 (MOLECULAR IMPRINTS, INC) 01 March 2018 (01.03.2018), para [0085]-[0090]	1-5
A	US 2017/0336552 A1 (SHARP KABUSHIKI KAISHA) 23 November 2017 (23.11.2017), entire document	1-5
A	US 5,790,731 A (DEVEAU) 04 August 1998 (04.08.1998), entire document	1-5

 Further documents are listed in the continuation of Box C. See patent family annex.

\* Special categories of cited documents:

"A" document defining the general state of the art which is not considered to be of particular relevance

"D" document cited by the applicant in the international application  
"E" earlier application or patent but published on or after the international filing date

"L" document which may throw doubts on priority claim(s) or which is cited to establish the publication date of another citation or other special reason (as specified)

"O" document referring to an oral disclosure, use, exhibition or other means

"P" document published prior to the international filing date but later than the priority date claimed

"T" later document published after the international filing date or priority date and not in conflict with the application but cited to understand the principle or theory underlying the invention

"X" document of particular relevance; the claimed invention cannot be considered novel or cannot be considered to involve an inventive step when the document is taken alone

"Y" document of particular relevance; the claimed invention cannot be considered to involve an inventive step when the document is combined with one or more other such documents, such combination being obvious to a person skilled in the art

"&amp;" document member of the same patent family

Date of the actual completion of the international search

25 February 2020

Date of mailing of the international search report

19 MAR 2020

Name and mailing address of the ISA/US

Mail Stop PCT, Attn: ISA/US, Commissioner for Patents  
P.O. Box 1450, Alexandria, Virginia 22313-1450  
Facsimile No. 571-273-8300

Authorized officer

Lee Young

Telephone No. PCT Helpdesk: 571-272-4300

INTERNATIONAL SEARCH REPORT

International application No.

PCT/US 19/58931

**Box No. II Observations where certain claims were found unsearchable (Continuation of item 2 of first sheet)**

This international search report has not been established in respect of certain claims under Article 17(2)(a) for the following reasons:

- 1.  Claims Nos.:  
because they relate to subject matter not required to be searched by this Authority, namely:
  
- 2.  Claims Nos.:  
because they relate to parts of the international application that do not comply with the prescribed requirements to such an extent that no meaningful international search can be carried out, specifically:
  
- 3.  Claims Nos.:  
because they are dependent claims and are not drafted in accordance with the second and third sentences of Rule 6.4(a).

**Box No. III Observations where unity of invention is lacking (Continuation of item 3 of first sheet)**

This International Searching Authority found multiple inventions in this international application, as follows:

This application contains the following inventions or groups of inventions which are not so linked as to form a single general inventive concept under PCT Rule 13.1. In order for all inventions to be searched, the appropriate additional search fees must be paid.

Group I: Claims 1-5 drawn to an eyepiece assembly comprising a polymer and adhesive with the same coefficient of thermal expansion.

Group II: Claims 6-14, drawn to an eyepiece and method comprising a contact angle of water on a surface of the waveguides exceeds 90 degrees.

Group III: Claims 15-25, drawn to an eyepiece assembly comprising an orthogonal pupil expander.

--see extra sheet

- 1.  As all required additional search fees were timely paid by the applicant, this international search report covers all searchable claims.
- 2.  As all searchable claims could be searched without effort justifying additional fees, this Authority did not invite payment of additional fees.
- 3.  As only some of the required additional search fees were timely paid by the applicant, this international search report covers only those claims for which fees were paid, specifically claims Nos.:
  
- 4.  No required additional search fees were timely paid by the applicant. Consequently, this international search report is restricted to the invention first mentioned in the claims; it is covered by claims Nos.:  
1-5

**Remark on Protest**

- The additional search fees were accompanied by the applicant's protest and, where applicable, the payment of a protest fee.
- The additional search fees were accompanied by the applicant's protest but the applicable protest fee was not paid within the time limit specified in the invitation.
- No protest accompanied the payment of additional search fees.

Continuation of Box No. III -- Observations where unity of invention is lacking:

The inventions listed in the above-mentioned groups do not relate to a single general inventive concept under PCT Rule 13.1 because, under PCT Rule 13.2, they lack the same or corresponding special technical features for the following reasons:

**Special Technical Features**

Group I includes the special technical feature of a polymer and adhesive with the same coefficient of thermal expansion, not included in the other groups.

Group II includes the special technical feature of comprising a contact angle of water on a surface of the waveguides exceeds 90 degrees, not included in the other groups.

Group III includes the special technical feature of a grating region comprising an orthogonal pupil expander, not included in the other groups.

**Common Technical Features:**

The only technical feature shared by Groups I-III that would otherwise unify the groups is an eyepiece assembly comprising, a first cover layer and second cover layer, a multiplicity of optical waveguides is positioned between the first cover layer and the second cover layer, and an adhesive. However, this shared technical feature does not represent a contribution over prior art, because the shared technical feature is disclosed by US 2018/0059320 A1 to Molecular Imprints, Inc. (hereinafter Molecular) 01 March 2018 (01.03.2018).

Molecular discloses an eyepiece assembly comprising: a multiplicity of optical waveguides positioned between the first cover layer and the second cover layer and an adhesive; and first and second cover layer (para [0085]-[0090] - In the embodiment illustrated by FIG. 7, first layer 708A may comprise a material, such as an epoxy, having a first index of refraction. The first index of refraction of first layer 708A may be similar to or substantially the same as the index of refraction of eyepiece stack 702 such that light 710 traveling toward outer edge 704 of eyepiece stack 702 may pass through an interface between outer edge 704 of eyepiece stack 702 and edge material 706 into first layer 708A. Matching the index of refraction between eyepiece stack 702 and first layer 708A allows for light 710 to pass through the interface with minimal refraction, reflection, and/or scatter of light back toward eyepiece stack 702. -The ratio of embedded particles 716 to base material 714 may vary depending on desired performance of the layer. For example, a single layer, such as an adhesive tape applied to the exterior of eyepiece stack 702 may have a weight per weight (w/w) of 5 percent. In some embodiments, higher or lower ratios of embedded particles 716 to base material 714 may also be used to optimize performance of edge material 706 across multiple layers. -The base material 714 of third layer 708C may be selected to have the same or similar index of refraction as the base material of second layer 708B. Having a same or similar index of refraction between the layers facilitates light 710 crossing through the interface between second and third layers 708B, 708C, respectively).

As the common technical feature was known in the art at the time of the invention, this cannot be considered a special technical feature that would otherwise unify the groups.

Therefore, Groups I-III lack unity under PCT Rule 13.