



- (51) International Patent Classification:  
*H05B 37/02* (2006.01)      *H04L 12/40* (2006.01)
- (21) International Application Number:  
PCT/EP2018/058837
- (22) International Filing Date:  
06 April 2018 (06.04.2018)
- (25) Filing Language: English
- (26) Publication Language: English
- (30) Priority Data:  
17165649.9      10 April 2017 (10.04.2017)      EP
- (71) Applicant: **PHILIPS LIGHTING HOLDING B.V.**  
[NL/NL]; High Tech Campus 45, 5656 AE Eindhoven (NL).
- (72) Inventors: **ABBO, Anteneh, Alemu**; c/o High Tech Campus 45, 5656 AE Eindhoven (NL). **HAVERLAG, Marco**; c/o High Tech Campus 45, 5656 AE Eindhoven (NL). **WOUTERS, Petrus, Nicolaas**; c/o High Tech Campus 45, 5656 AE Eindhoven (NL).

- (74) Agent: **TAKKEN, Robert, Martinus, Hendrikus** et al.; Philips Lighting B.V. - Intellectual Property High Tech Campus 45, 5656 AE Eindhoven (NL).
- (81) Designated States (*unless otherwise indicated, for every kind of national protection available*): AE, AG, AL, AM, AO, AT, AU, AZ, BA, BB, BG, BH, BN, BR, BW, BY, BZ, CA, CH, CL, CN, CO, CR, CU, CZ, DE, DJ, DK, DM, DO, DZ, EC, EE, EG, ES, FI, GB, GD, GE, GH, GM, GT, HN, HR, HU, ID, IL, IN, IR, IS, JO, JP, KE, KG, KH, KN, KP, KR, KW, KZ, LA, LC, LK, LR, LS, LU, LY, MA, MD, ME, MG, MK, MN, MW, MX, MY, MZ, NA, NG, NI, NO, NZ, OM, PA, PE, PG, PH, PL, PT, QA, RO, RS, RU, RW, SA, SC, SD, SE, SG, SK, SL, SM, ST, SV, SY, TH, TJ, TM, TN, TR, TT, TZ, UA, UG, US, UZ, VC, VN, ZA, ZM, ZW.
- (84) Designated States (*unless otherwise indicated, for every kind of regional protection available*): ARIPO (BW, GH, GM, KE, LR, LS, MW, MZ, NA, RW, SD, SL, ST, SZ, TZ, UG, ZM, ZW), Eurasian (AM, AZ, BY, KG, KZ, RU, TJ, TM), European (AL, AT, BE, BG, CH, CY, CZ, DE, DK, EE, ES, FI, FR, GB, GR, HR, HU, IE, IS, IT, LT, LU, LV, MC, MK, MT, NL, NO, PL, PT, RO, RS, SE, SI, SK, SM,

(54) Title: SYSTEM AND METHOD FOR ENHANCING DATA RATES OVER ADDRESSABLE LIGHTING NETWORKS

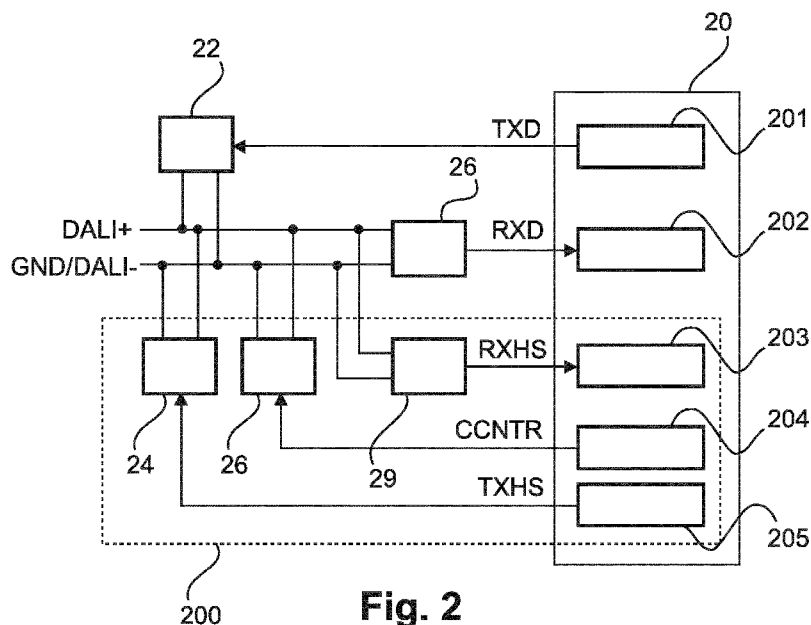

Fig. 2

(57) Abstract: The present invention relates to a signaling system, methods and computer program products for increasing data rate of addressable lighting networks (e.g. DALI networks). A bus clamping technique is suggested to allow fast data communication without affecting operation of normal network devices. The proposed scheme is useful in applications such as outdoor luminaires where the network data rate is too low for use cases that require 5 real-time microphone or image data transfer, for example.



TR), OAPI (BF, BJ, CF, CG, CI, CM, GA, GN, GQ, GW,  
KM, ML, MR, NE, SN, TD, TG).

**Declarations under Rule 4.17:**

- *as to applicant's entitlement to apply for and be granted a patent (Rule 4.17(ii))*

**Published:**

- *with international search report (Art. 21(3))*

## SYSTEM AND METHOD FOR ENHANCING DATA RATES OVER ADDRESSABLE LIGHTING NETWORKS

### FIELD OF THE INVENTION

The invention relates to the field of data communication in addressable lighting networks based on a communication standard, such as – but not limited to – the Digital Addressable Lighting Interface (DALI) standard.

5

### BACKGROUND OF THE INVENTION

DALI is a dedicated protocol for lighting control. A DALI system may comprise a control gear, control devices and bus power supplies. The control gear usually contains a power control circuit to drive lamps or luminaires, or some other type of output  
10 such as on/off switching or analogue signals. The control devices can provide information to other control devices (such as light intensity information), and can send commands to the control gear. Furthermore, input devices are a type or a part of a control device that provides some information to the system, such as a button press or movement detection. Additionally, application controllers are a type or a part of a control device and are the decision makers in a  
15 DALI system – for example, they can send commands to the control gear to modify the lighting. At least one bus power supply can be present in a DALI system. This is necessary to allow both communications on the bus, as well as to power any bus-powered devices. The bus power supply does not need to be a separate unit – it could be part of another device such as a light emitting diode (LED) driver or a sensor.

20

DALI communication standard is very widely utilized in modern lighting control systems. While its common usage is for room/floor/building level lighting control, new applications are also emerging where it is used for connecting devices within luminaires. This new application is made possible by the emergence of drivers that include DALI power supply, e.g., Philips Advance Xitanium SR LED Driver.

25

Fig. 1 shows typical luminaire electrical architectures (a) and (b) for indoor and, respectively, outdoor luminaires based on DALI drivers (e.g. Xitanium-SR drivers). In the indoor case (a), a DALI master 14 and slave modules 12-1 and 12-2 are powered via a DALI bus system with positive and negative connection lines DALI+ and DALI- from a DALI power supply (not shown) provided in a DALI driver 10 (e.g. a DALI LED driver). In

the outdoor case (b), an extra power supply is integrated in the DALI driver 10 to handle high-power demand through a separate voltage supply line VSUP, while the negative connection line DALI- may be grounded (GND).

Although robust with respect to noise and interference, one of the main  
5 limitations of the DALI protocol is its low data rate (1200 b/s), as can be gathered e.g. from DALI application note AN1465 of Microchip technology Inc., 2012, or from the DALI Manual of the DALI Activity Group of ZVEI's Division Luminaires, Frankfurt, 2001.

In traditional applications where simple lighting control commands are sent  
10 over a long DALI cable, this data rate is sufficient. However, new use cases such as software upgrade, reading out status data and communicating with high-speed data sources (audio or video) will suffer from this data rate restriction. Moreover, communication overhead of the DALI protocol is a concern which reduces the effective data rate to about  $400 \text{ b/s} = 33.3\% \times 1200 \text{ b/s}$ .

## 15 SUMMARY OF THE INVENTION

It is an object of the present invention to provide a simple and reliable signaling approach to allow increased data rates on addressable low-rate lighting networks such as the DALI network.

This object is achieved by a system as claimed in claim 1, by a transmitting  
20 apparatus as claimed in claim 2, by a slave device as claimed in claim 5, by a receiving apparatus as claimed in claim 6, by a master device as claimed in claim 10, by a luminaire device as claimed in claim 12, by a transmitting method as claimed in claim 13, by a receiving method as claimed in claim 14, and by a computer program product as claimed in claim 15.

25 Accordingly, a master device of a data bus of the addressable lighting network is notified about a need for high-speed data transmission in order to trigger a clamping of the transmission voltage level on the data bus below a lowest detection threshold level used for low-speed data transmission on the data bus. Then, a mode control signal is activated in response to a detected request for high-speed transmission on the data bus and the  
30 transmission voltage on the data bus is clamped to a level below the lowest detection threshold level, and a high-speed data transmission via the data bus is initiated in response to a detection of a reduced voltage level on the data bus, which is below the lowest detection threshold level. Thereby, the data rate on the data bus can be increased while the signaling system can be kept compatible to the standard (low-speed) system operation. The main

concept relies on the idea of clamping the bus voltage to a level below the lowest threshold voltage (e.g., 6.5V) so that normal network devices do not get disturbed. To enable this, a protocol may be provided where a bus master device (e.g., a DALI bus master) is notified of the need for high-speed communication by one/more of the slave devices (e.g., DALI slaves) so that it activates the bus-clamp control. The requesting slave device would subsequently activate a high-speed signalling to transfer the data to the master device. On the receiving side, the detection threshold is lowered to match the new operating voltage range and appropriate decoding of the received signal is done. In one embodiment, a high-speed half-duplex Universal Asynchronous Receiver Transmitter (UART) protocol may be used to exploit widely available microcontroller peripherals as physical layer.

According to a first option, the apparatus may comprise a multiplexer for selectively providing to the data bus either low-speed transmission data generated by a low-speed encoder or high-speed transmission data generated by a high-speed encoder to a bus driver connected to the data bus. Thereby, circuit complexity can be reduced by using the same bus driver for low-speed and high-speed transmission.

According to a second option which can be combined with the first option, the notification unit may be adapted to notify the master device by polling or event-based signaling over the data bus. This allows easy realization of the proposed dual transmission scheme since the bus master is in control of the added high-speed sessions.

According to a third option which can be combined with the first or second option, a high-threshold receiver may be provided for receiving low-speed data transmitted via the data bus at a voltage level above or equal to the lowest detection threshold level. The combined provision of low and high-threshold receivers provides an option for detecting the status of bus clamping by comparing respective output signals of the low and high-threshold receivers.

According to a fourth option which can be combined with any one of the first to third options, the bus clamp circuit may comprise a voltage limitation element, such as a Zener diode or a limitation circuit or the like, adapted to restrict a voltage swing of the transmission voltage on the data bus, and a switching element that activates the voltage limitation element and that is controlled by the mode control signal. This measure allows simple and reliable implementation of the bus clamping function.

According to a fifth option which can be combined with any one of the first to fourth options, the clamping of the bus clamp circuit may be restricted to a predetermined maximum time duration allowed for high-speed data transmission over the data bus. Thereby,

the duration of the high-speed transmission can be matched to maximum allowed bus idle periods so as to prevent bus error conditions.

It is noted that the above transmitting and receiving apparatuses may be implemented based on discrete hardware circuitries with discrete hardware components, integrated chips, or arrangements of chip modules, or based on signal processing devices or  
5 chips controlled by software routines or programs stored in memories, written on a computer readable media, or downloaded from a network, such as the Internet.

It shall be understood that the system of claim 1, the transmitting apparatus of claim 2, the slave device of claim 5, the receiving apparatus of claim 6, the master device of claim 10, the luminaire device of claim 12, the transmitting method of claim 13, the  
10 receiving method of claim 14, and the computer program product of claim 15 may have similar and/or identical preferred embodiments, in particular, as defined in the dependent claims.

It shall be understood that a preferred embodiment of the invention can also be any combination of the dependent claims or above embodiments with the respective  
15 independent claim.

These and other aspects of the invention will be apparent from and elucidated with reference to the embodiments described hereinafter.

## 20 BRIEF DESCRIPTION OF THE DRAWINGS

In the following drawings:

Fig. 1 shows schematic architectures of addressable lighting networks for indoor and outdoor luminaires, respectively;

Fig. 2 shows a schematic block diagram of a master device according to a first  
25 embodiment;

Fig. 3 shows a schematic block diagram of a master device according to a second embodiment;

Fig. 4 shows an exemplary circuit diagram of a bus-type transmission system with selectable data rate according to a third embodiment;

Fig. 5 shows signaling diagrams with waveforms of low data rate signaling followed by high data rate communication;  
30

Fig. 6 shows signaling diagrams zoomed in to show part of the high data rate communication at higher resolution; and

Fig. 7 shows a schematic flow diagram of a procedure according to a fourth embodiment for enhancing data rate on a data bus.

#### DETAILED DESCRIPTION OF EMBODIMENTS

5 Embodiments of the present invention will be described below based on a DALI architecture of a lighting network.

Fig. 2 shows a schematic block diagram of a proposed communication architecture of a master device according to a first embodiment to allow high-speed data transfer over DALI bus lines DALI+ and GND/DALI-. The master device comprises a first bus driver 22 and a conventional DALI (high) threshold receiver 28 for low-speed  
10 communication. Additionally, a microcontroller 20 is provided as a control unit for implementing a conventional DALI encoder 201 which generates low-rate transmission data TXD supplied to the first bus driver 22. Furthermore, the microcontroller 20 implements a conventional DALI decoder 202 which receives low-rate reception data RXD outputted from  
15 the DALI threshold receiver 28.

In addition, a high-level functional architecture of the proposed communication data-rate enhancement concept according to the first embodiment is shown in Fig. 2, wherein the above conventional DALI architecture is augmented with an additional high-speed communication section 200 comprising additional components, such as a second  
20 bus driver 24, a bus clamp circuit 26, a low-threshold receiver 29 and corresponding additional resources implemented in the microcontroller 20, such as a high-speed encoder 205, a mode selector 204 and a high-speed decoder 203. When high-speed communication needs to take place, which may be signalled by a slave device to the master device via the data bus, the mode selector 204 activates a clamp control signal CCNTR supplied to the bus  
25 clamp circuit 26.

Even though all devices connected to the data bus that can operate in high-speed mode could be adapted to activate the bus clamp circuit 26, it is preferred to do this only at the master device to avoid unnecessary racing conditions on the DALI bus.

When the bus clamp function of the bus clamp circuit 26 is activated so as to  
30 limit the signalling voltage on the DALI bus to a level below the lowest threshold level, the DALI threshold receiver 28 cannot receive the limited low-level signal on the DALI bus and therefore outputs a low-speed reception signal RXD = "0", while the low-threshold receiver 29 can receive the low-level signal and outputs a high-speed reception signal RXHS = "1". These logical states of the output signals RXD and RXHS indicate to the respective decoders

202, 203 of the microcontroller 20 that the bus is ready for high-speed operation and requesting slave(s) can start their high-speed data transfer at low voltage level if allowed by the bus master. Optionally, it is also possible to monitor the analog bus voltage level directly to detect if the bus is ready.

5 Fig. 3 shows a schematic block diagram of a proposed communication architecture of a master device according to a second embodiment to allow high-speed data transfer over DALI bus lines DALI+ and GND/DALI-. Same components as those shown in Fig. 2 are denoted by the same reference signs and are not described again. In the second embodiment, shared (hardware) resources for both normal DALI and high-data rate  
10 communication are provided. As shown in Fig. 3, it is also possible to share resources for normal DALI and high-speed communication. As an example, the bus driver is the simplest module to be shared. Thus, the first bus driver 22 in Fig. 2 can be omitted and low-speed transmission data can also be supplied to the DALI bus via the second bus driver (combined bus driver) 24 of a high-speed communication section 300 with shared resources. To achieve  
15 this, a multiplexer 301 can be implemented in an enhanced microcontroller 30 to provide a selective switching function for switching either the high-speed data generated by the high-speed encoder 205 or the low-speed data generated by the conventional DALI encoder 201 to the combined bus driver 24 in dependence on the detected type of transmission speed.

Even though the two receivers 28 and 29 could also be combined by making  
20 the threshold adaptive (e.g., by using the clamp control signal CCNTR), it is advantageous to keep them separate to be able to use the feature of bus state monitoring via the reception signal RXD and RXHS, as explained above.

Fig. 4 shows an exemplary circuit diagram of a bus-type transmission system with selectable data rate according to a third embodiment.

25 It is noted that only those circuit components of a master device 14 and a slave devices 12 of the transmission system are shown that are useful for explaining the present invention are shown in Fig. 4. The master and slave devices 14 and 12 are coupled to the DALI bus by respective diode circuits consisting of Schottky diodes D1 to D4 and D10 to D13, respectively. The signal voltages of the master device 14 are referenced to reference  
30 potential COM2, while the signal voltages of the slave device 12 are referenced to reference potential COM1.

In case of the master device 14, the bus clamp circuit (BC) is realized by using a Zener diode D14 as voltage limitation element that restricts the voltage swing of the DALI bus (bus lines DALI+ and DALI-) and a transistor switch Q5 that is controlled by the clamp

control signal CCNTR supplied from a voltage source V5 which represents the mode selector 204 in Figs. 2 and 3.

High-speed receiving (HS-RX) is realized by using a comparator U1 with a low detection threshold level at one input set by resistors R6 and R7 to divide a supply  
5 voltage V3V3 to a suitable voltage level as determined by the low detection threshold level. The other input of the comparator U1 is connected to the clamped bus voltage divided by voltage dividing resistors R4 and R5 and protected by another Zener diode D6. The comparator U1 outputs the high-speed reception signal RXHS.

By contrast, the normal DALI receiver (DALI-RX) has a higher threshold  
10 level due to a further Zener diode D7 with higher clamping level. It is realized by a transistor Q1 and outputs the normal DALI reception signal RXD.

Also shown is an optional power extraction unit using rectifier Schottky diode D5 and filter capacitors C2 and C3 and a voltage down converter V1 which generates the supply voltage V3V3 (e.g. 3.3V).

15 On the slave side, separate transmitting circuits (HS-TX and DALI-TX) with respective transistors Q2 and Q4 are shown for a high-rate signal TXDHS (supplied from a voltage source V2 which represents the high-speed encoder) and a low-rate DALI signal TXD (supplied from a voltage source V4 which represents the DALI encoder). The transmitting circuits could optionally be combined if needed.

20 Similar to the master device 14, the slave device 12 may comprise an optional power extraction unit using rectifier Schottky diode D8 and filter capacitors C6 and C7 and a voltage down converter V3 which generates the supply voltage V3V3 (e.g. 3.3V) for the circuitry.

To verify the circuit operation, a simulation setup was built using models for a  
25 DALI power supply and respective sensor modules. The simulation results are shown in Figs. 5 and 6.

Fig. 5 shows signaling diagrams with waveforms of voltages of the signals RXHS (V(rxhs.com2)), TXDHS (V(txdhs.com1)), RXD (V(rxd.com2)), TXD (V(txd.com1)) and CCNTR (V(ccntr.com2)) and the bus voltage (V(dali+)) in case of a low data rate  
30 signaling followed by high data rate communication.

During the initial normal DALI transmission phase from 0 to 16.5ms, the bus master doesn't activate the bus clamp (i.e. CCNTR = "0") so that the signal voltage on the DALI bus is at its highest voltage level (e.g. about 16V). By activating the signal TXD at 2ms, the slave device puts a low frequency (e.g. 1200 Hz) signal on the DALI bus which is

properly detected by the high-threshold receiver at the master side (RXD). Actually, the low-threshold receiver also detects the DALI rate pulses (as shown by RXHS). However this signal is not further processed by the microcontroller as the DALI signalling protocol (i.e. Manchester encoding) is not directly compatible with the high-speed signalling protocol (e.g. Universal Asynchronous Receiver Transmitter (UART) protocol) used for decoding pulses in high-speed mode.

The bus clamping is activated at 16.5ms after the CCNTR signal has been set to “1” following which a high-speed (e.g. 200 kHz) signal is put on the DALI bus when the slave device activates the TXDHS signal. The clamped low voltage level on the bus from 16.5ms to 18.5ms can be seen as a hatched area in the lowest waveform of Fig. 5. On the receiver side (the master module), the high-speed data is properly detected as shown by the RXHS waveform. During this interval the normal DALI output RXD of the master module simply stays at logic “1” level indicating that normal DALI devices are not disturbed.

Fig. 6 shows signaling diagrams zoomed in to show part of the high data rate communication from 16.6ms to 16.7ms at higher resolution.

The lowest waveform in Fig. 6 signal shows the bus voltage clamped to the low level (e.g. about 5V) when the CCNTR signal is activated. The normal DALI received signal (RXD) stays at logic “1” when the high data rate pulses are transmitted over the bus.

Fig. 7 shows a schematic flow diagram of a procedure according to a fourth embodiment for enhancing data rate on a data bus.

Respective parts of the procedure can be performed by a controller or processor provided in a master or slave device (e.g. luminaire device of an addressable lighting network) so as to temporarily enhance data rates for transmission.

Initially, in step 701, a slave device notifies a bus master of a need for high-speed communication over the data bus. Then, in step 702, responsive to a receipt of the notification, the bus master activates a bus clamp control so as to limit the signaling voltage on the data bus to a level below the lowest detection threshold of usual low-speed transmission. In the subsequent step 703, the slave node detects the reduced voltage level on the data bus and starts high-speed signaling. In step 704, the detection threshold at the receiving side (master device or addressed other slave device) of the transmission is correspondingly lowered to match the new operating voltage range for high-speed transmission. Finally, in step 705, the received high-speed signal is decoded at the receiving side.

In the above embodiments, the time multiplexing of the DALI bus for normal and high-speed data communication can be controlled by a protocol sequence that can be observed by devices connected to the bus. The proposed master-slave arrangement eases realization of the proposed scheme since the bus master is in control of the starting and stopping of high-speed sessions. Either polling or event based protocol signalling can be adopted to let the master device know if a slave has important data to be transferred as high-speed data. Such a polling or initial event signalling could be run at normal DALI data rate.

In general, the notification (e.g. request or command) for high-speed signaling can be done in various ways. Respective control signalling (e.g. control packets) can both be in low and high-speed modes. For example, the notification for initiation of high-speed mode can be sent via low-speed signaling while a notification to end high-speed signaling can be done using high-speed signaling since the concerned devices are then already in high-speed mode. Although high-speed signaling is initiated after the clamp-voltage is detected, the decision to clamp the voltage can be initiated when there is a need for high-speed communication. This need may be identified by an event or polling that uses the low-speed signaling. As mentioned above, it is optionally possible to also notify end of high-speed mode by sending a control packet or by another signaling. However, it is also possible to deduce this by simply monitoring the bus voltage level. I.e., if it returns to the highest level, this means that the temporary high-speed mode has ended.

In a first example, the master could poll slaves in low-speed mode to check if they have data that needs to be transferred at high-speed, and slaves could indicate their interest using the same low speed mode. In response, the master activates the bus clamping functionality, which will be noticed by slaves that are capable of high-speed signaling.

In an alternative second example, if the master wants to send data or software update in high-speed mode, it could either inform the concerned slave(s) via a control signaling in low-speed signaling mode and then do the bus clamp to start high-speed signaling, or, alternatively, it could directly start the high-speed mode by clamping the bus so that high-speed capable slaves can prepare themselves for incoming packets. With regard to efficient utilization of the available bus time slot, the second approach provides the advantage of avoiding time-consuming negotiation time spent in low-speed signaling.

Thus, high-speed communication can also be initiated by a master device. Then, a way of initiating high-speed mode could be to first send a special command using the low-speed mode so that all devices (slave/master) that can handle high-speed will prepare for

it. After a certain time of sending the initiation command, the bus clamping can be activated and communication can start.

Furthermore, the duration of high-data rate communication can be adjusted to match the limit allowed by the DALI protocol so as to prevent bus error conditions.

5 According to User Manual UM1629 for STM32L1xx DALI slave interface (DocID024499 Rev 1) of STMicroelectronics, January 2014, and Beckhoff's DALI Connectivity Library (TF8000 TC3), no error is generated if the DALI bus loses its IDLE state (bus voltage > 9.5V) for at most 500 ms. This is long enough to send a decent amount of data at the high-data rate. Thus, by making sure the bus returns to IDLE state before the timeout interval, it is  
10 possible to have successive sessions of high-speed communication. Moreover, as long as there is enough time left to do high-speed transmission, a second high-speed request could also be accommodated. Such multiple high-speed transactions can be handled without returning to the low-speed mode by releasing the bus clamp. This is advantageous in that the available transmission time can be utilized more effectively.

15 A timer can be used to make sure that the bus is not clamped longer than what is allowed by the bus protocol (e.g. DALI protocol). Thus, a single one or multiple high-speed transactions can be scheduled depending on the available time.

Of course, the suggested temporary selective high-speed transmission is not intended to be restricted to DALI lighting networks. Any addressable lighting network with  
20 master-slave architecture can be used for implementing the proposed non-disruptive enhancement.

To summarize, a signaling system, methods and computer program products for increasing data rate of addressable lighting networks (e.g. DALI networks) have been described. A bus clamping technique is suggested to allow fast data communication without  
25 affecting operation of normal network devices. The proposed scheme is useful in applications such as outdoor luminaires where the network data rate is too low for use cases that require real-time microphone or image data transfer, for example.

While the invention has been illustrated and described in detail in the drawings and foregoing description, such illustration and description are to be considered illustrative or  
30 exemplary and not restrictive. The invention is not limited to the disclosed embodiments. The proposed high-speed transmission can be applied to other types of networks and with other types of signals. The proposed idea could be applied in other applications where occasional data rate enhancement is required in otherwise low-data rate systems.

Other variations to the disclosed embodiments can be understood and effected by those skilled in the art in practicing the claimed invention, from a study of the drawings, the disclosure and the appended claims. In the claims, the word “comprising” does not exclude other elements or steps, and the indefinite article “a” or “an” does not exclude a plurality. A single processor or other unit may fulfil the functions of several items recited in the claims. The mere fact that certain measures are recited in mutually different dependent claims does not indicate that a combination of these measures cannot be used to advantage.

The foregoing description details certain embodiments of the invention. It will be appreciated, however, that no matter how detailed the foregoing appears in the text, the invention may be practiced in many ways, and is therefore not limited to the embodiments disclosed. It should be noted that the use of particular terminology when describing certain features or aspects of the invention should not be taken to imply that the terminology is being re-defined herein to be restricted to include any specific characteristics of the features or aspects of the invention with which that terminology is associated.

A single unit or device may fulfill the functions of several items recited in the claims. The mere fact that certain measures are recited in mutually different dependent claims does not indicate that a combination of these measures cannot be used to advantage.

The described operations like those indicated in Fig. 7 can be implemented as program code means of a computer program and/or as dedicated hardware. The computer program may be stored and/or distributed on a suitable medium, such as an optical storage medium or a solid-state medium, supplied together with or as part of other hardware, but may also be distributed in other forms, such as via the Internet or other wired or wireless telecommunication systems.

## CLAIMS:

1. A system for transmitting data over a data bus of an addressable lighting network, said system comprising:
- a transmitting apparatus comprising:
    - a notification unit (20; 30) for notifying a request for high-speed data transmission in order to trigger a clamping of the transmission voltage level on the data bus below a lowest detection threshold level used for low-speed data transmission on the data bus;
    - a low-speed transmission unit (201) for transmitting data via the data bus at a voltage level greater than or equal to the lowest detection threshold level and based on a low-speed transmission protocol; and
    - a high-speed transmission unit (205) for initiating high-speed data transmission via the data bus based on a high-speed transmission protocol in response to a detection of a reduced voltage level on the data bus, which is below the lowest detection threshold level;
- 15 wherein the system further comprises:
- a receiving apparatus comprising:
    - a mode selector (204) for activating a mode control signal in response to a detected request for high-speed transmission on the data bus;
    - a bus clamp circuit (26) for clamping a transmission voltage on the data bus to a level below the lowest detection threshold level used for low-speed data transmission on the data bus, in response to an activation of the mode control signal; and
    - a low-threshold receiver (29) for receiving high-speed data transmitted via the data bus at a voltage level below the lowest detection threshold level and based on the high-speed transmission protocol.
- 25
2. A transmitting apparatus for transmitting data over a data bus of an addressable lighting network, said transmitting apparatus comprising:
- a notification unit (20; 30) for notifying a request for high-speed data transmission in order to trigger a clamping of the transmission voltage level on the data

bus below a lowest detection threshold level used for low-speed data transmission on the data bus;

- a low-speed transmission unit (201) for transmitting data via the data bus at a voltage level greater than or equal to the lowest detection threshold level and based on a low-speed transmission protocol; and

- a high-speed transmission unit (205) for initiating high-speed data transmission via the data bus based on a high-speed transmission protocol in response to a detection of a reduced voltage level on the data bus, which is below the lowest detection threshold level.

10

3. The apparatus of claim 2, wherein the apparatus comprises a multiplexer (301) for selectively providing low-speed transmission data generated by the low-speed transmission unit (201) or high-speed transmission data generated by the high-speed transmission unit (205) to a bus driver (24) connected to the data bus.

15

4. The apparatus of claim 2 or 3, wherein the notification unit (20; 30) is adapted to notify a master device (14) of the data bus by polling or event-based signaling over the data bus.

20

5. A slave device for transmitting or receiving data over a data bus of an addressable lighting network, wherein the slave device (12-1, 12-2) comprises an apparatus of claim 2.

25

6. A receiving apparatus for receiving data over a data bus of an addressable lighting network comprising:

- a mode selector (204) for activating a mode control signal in response to a detected request for high-speed transmission on the data bus;

- a bus clamp circuit (26) for clamping a transmission voltage on the data bus to a level below a lowest detection threshold level used for low-speed data

30

transmission on the data bus, in response to an activation of the mode control signal; and

- a low-threshold receiver (29) for receiving high-speed data transmitted via the data bus at a voltage level below the lowest detection threshold level and based on a high-speed transmission protocol.

7. The apparatus of claim 6, further comprising a high-threshold receiver (28) for receiving low-speed data transmitted via the data bus at a voltage level above or equal to the lowest detection threshold level and based on a low-speed transmission protocol.
- 5 8. The apparatus of claim 6, wherein the bus clamp circuit (26) comprises a voltage limitation element (D14) adapted to restrict a voltage swing of the transmission voltage on the data bus and a switching element (Q4) that activates the voltage limitation element (D14) and that is controlled by the mode control signal.
- 10 9. The apparatus of claim 6, wherein the apparatus is adapted to restrict the clamping of the bus clamp circuit (26) to a predetermined maximum time duration allowed for an idle state on the data bus.
10. A master device (10, 14; 11, 14) for connection to a data bus of an addressable  
15 lighting network, wherein the master device comprises at least one of a transmitting apparatus of claim 2 and a receiving apparatus of claim 6.
11. The master device of claim 10, further comprising a power supply unit for supplying power via the data bus to connected master or slave devices.
- 20 12. A luminaire device connectable to an addressable lighting network via a data bus, the luminaire device comprising a slave device of claim 3 or a master device of claim 10.
- 25 13. A method of transmitting data over a data bus of an addressable lighting network, the method comprising:  
- notifying (701) a master device (10, 14; 11, 14) of the data bus about a need for high-speed data transmission in order to trigger a clamping of the transmission voltage level on the data bus below a lowest detection threshold level used for low-speed data transmission on the data  
30 bus; and  
- initiating (703) high-speed data transmission via the data bus based on a high-speed transmission protocol in response to a detection of a reduced voltage level on the data bus, which is below the lowest detection threshold level.

14. A method of receiving data from a data bus of an addressable lighting network, the method comprising:
- activating (702) a mode control signal in response to a detected request for high-speed transmission on the data bus;
  - 5 - clamping a transmission voltage on the data bus to a level below a lowest detection threshold level used for low-speed data transmission based on a low-speed transmission protocol on the data bus, in response to an activation of the mode control signal; and
  - receiving (704) high-speed data transmitted via the data bus at a voltage level below the lowest detection threshold level and based on a high-speed transmission protocol.
- 10
15. A computer program product comprising code means for producing the steps of claim 13 or 14 when run on a computer device.

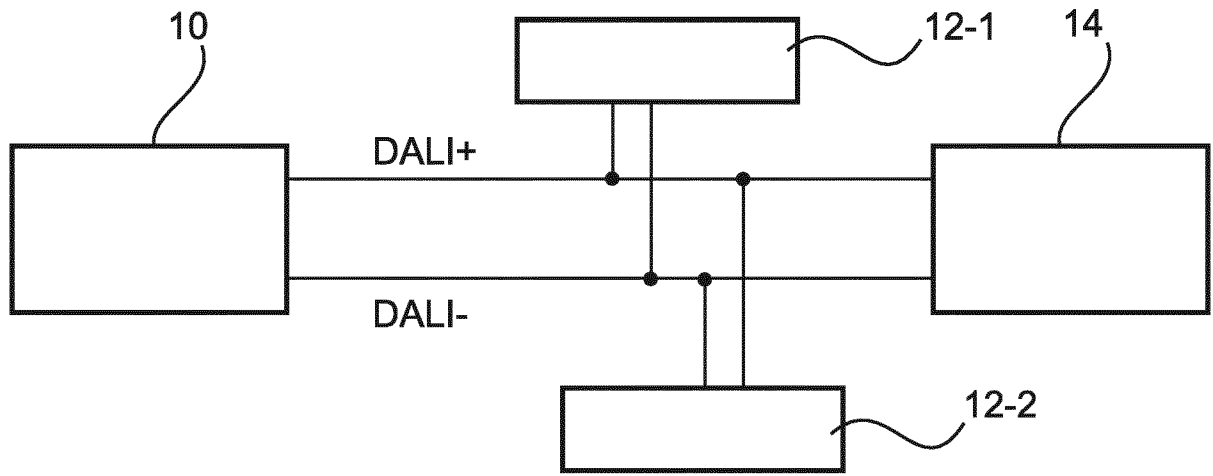

(a)

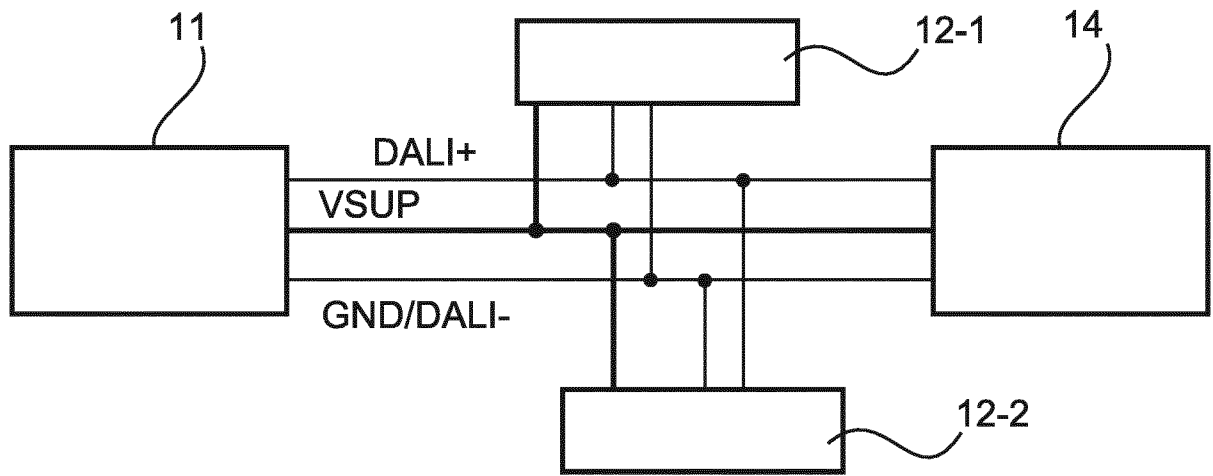

(b)

Fig. 1

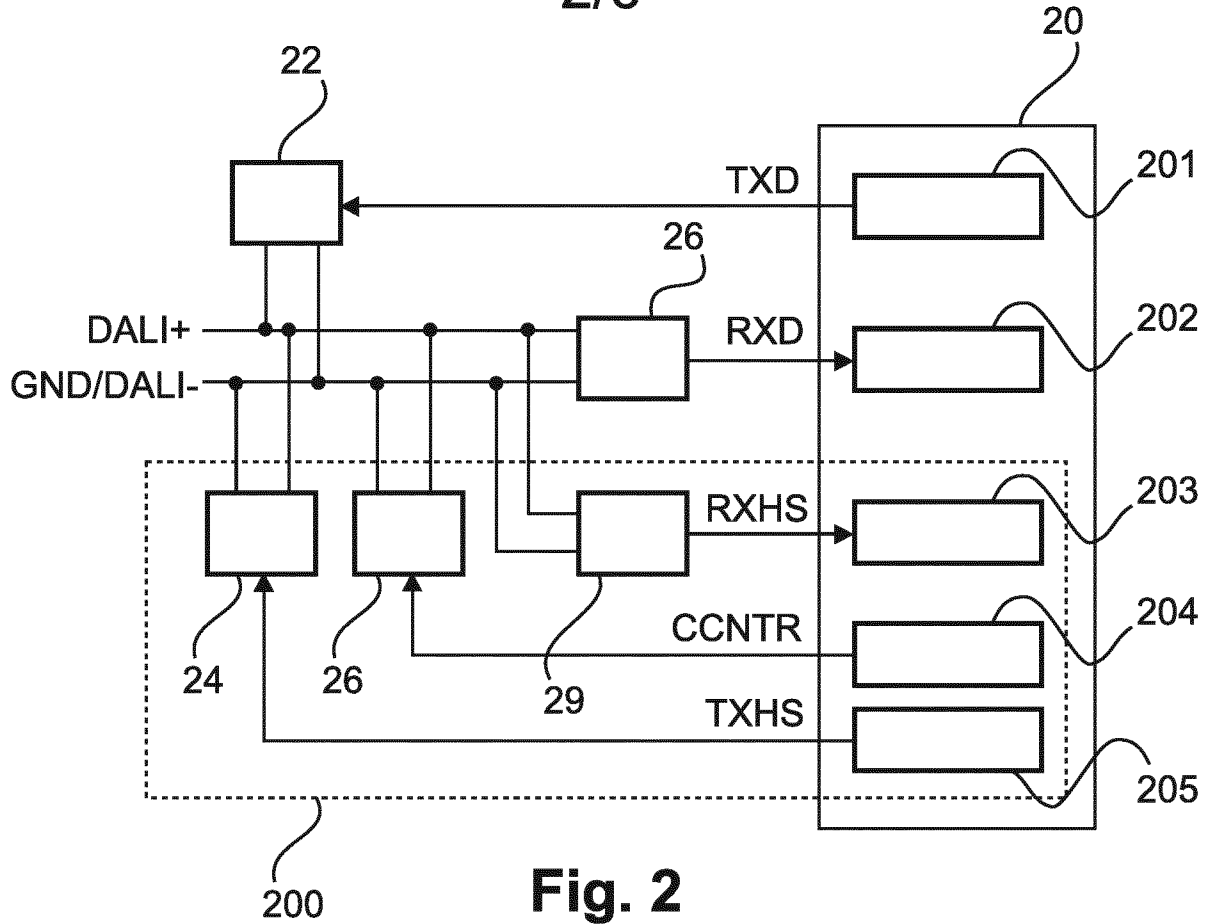

Fig. 2

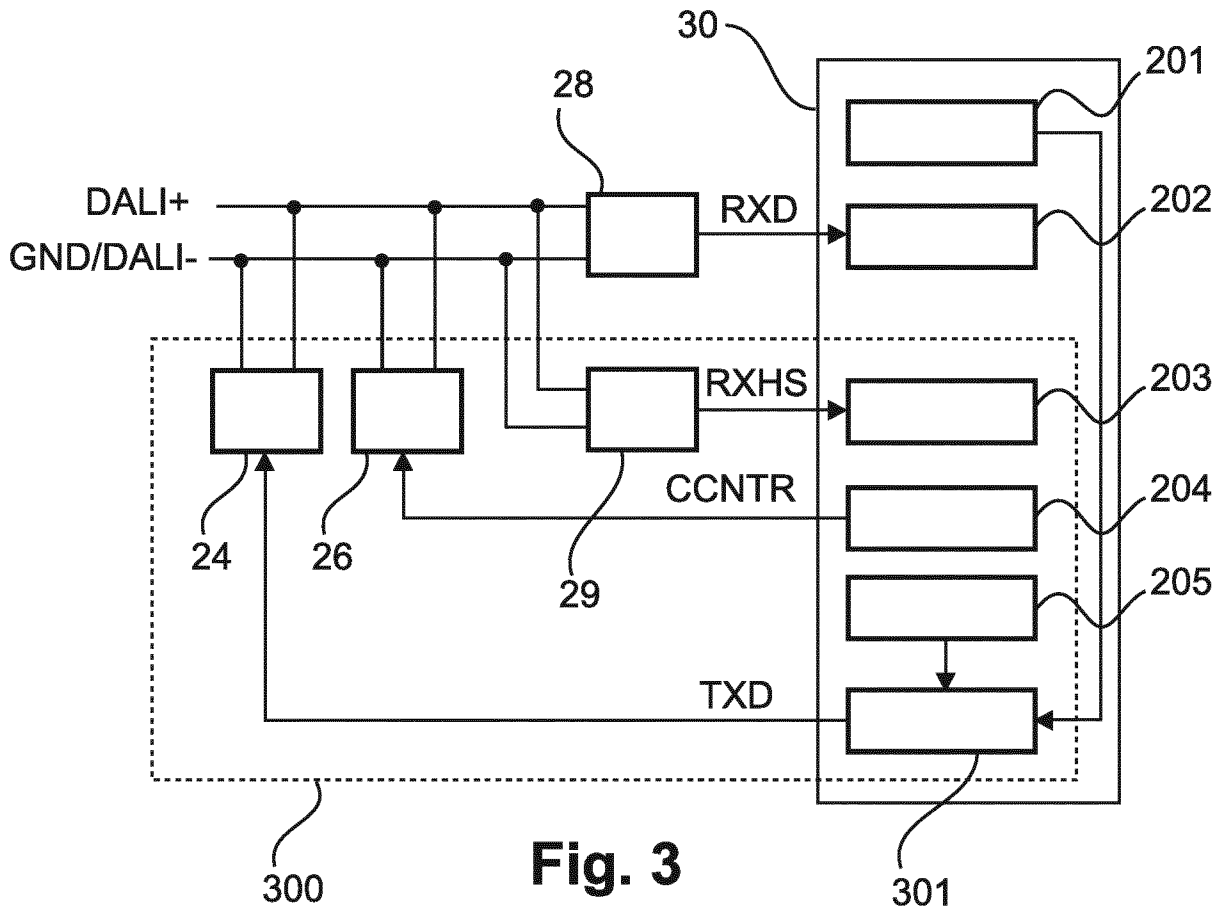
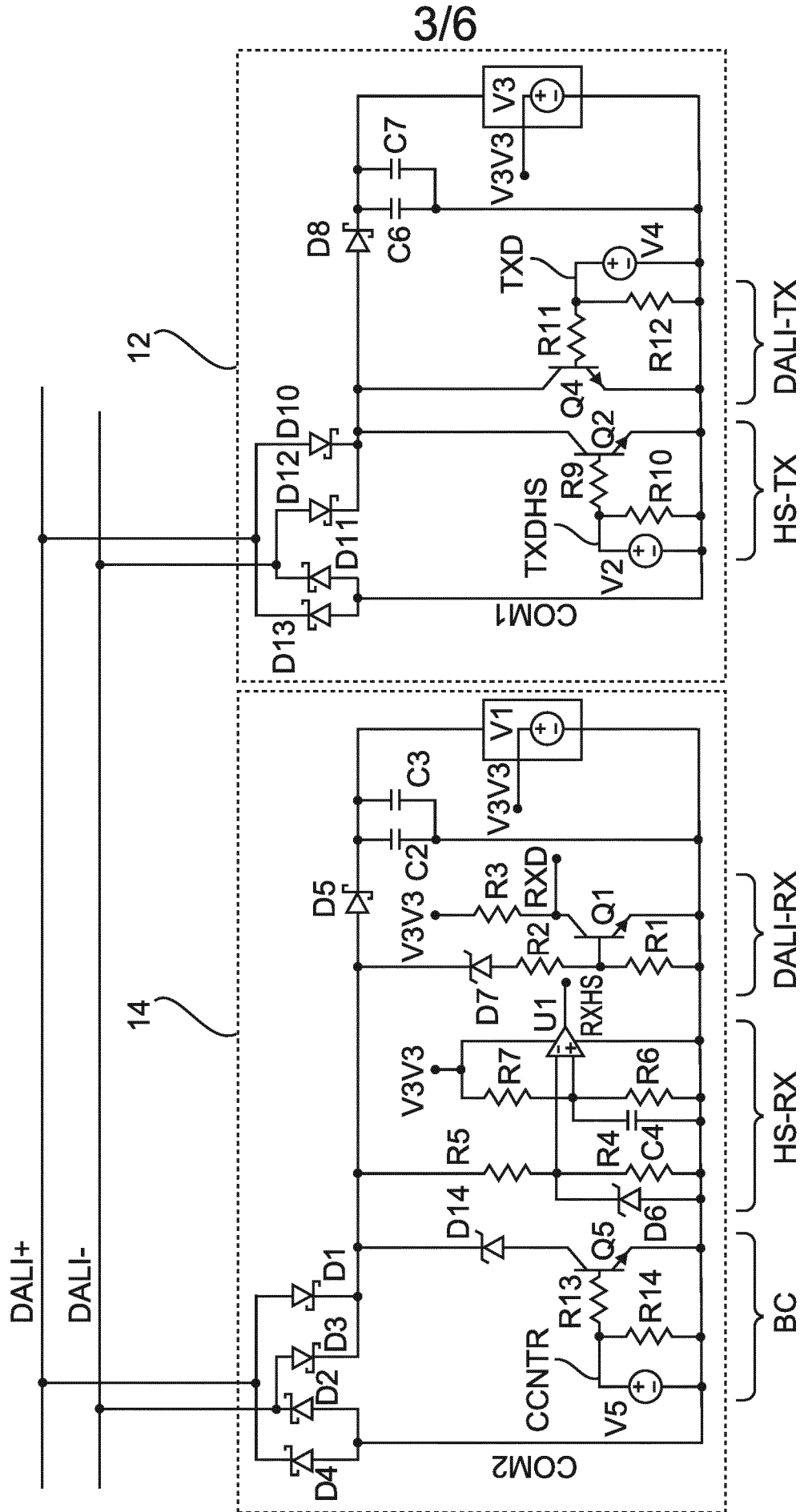

Fig. 3



3/6

FIG. 4

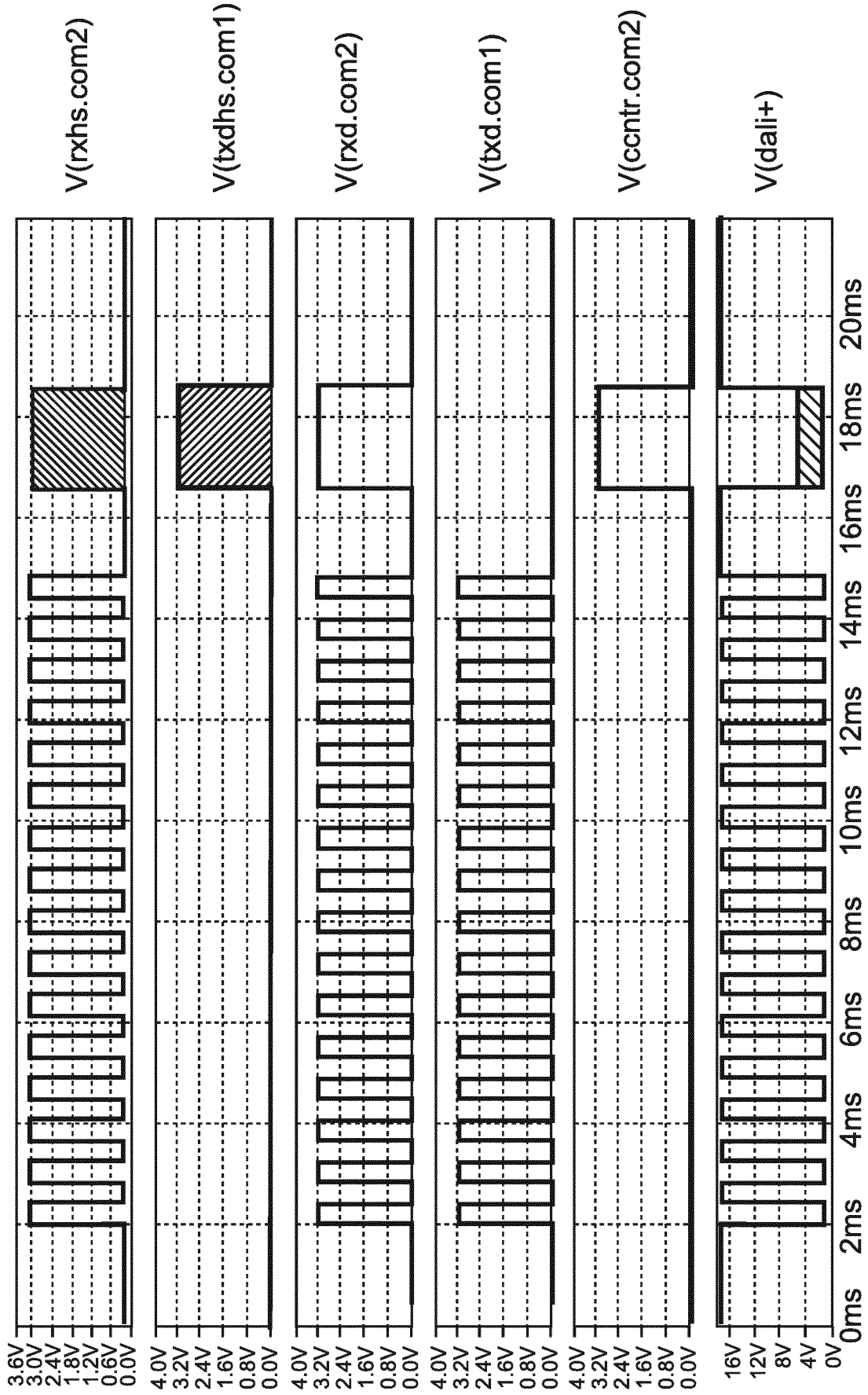

FIG. 5

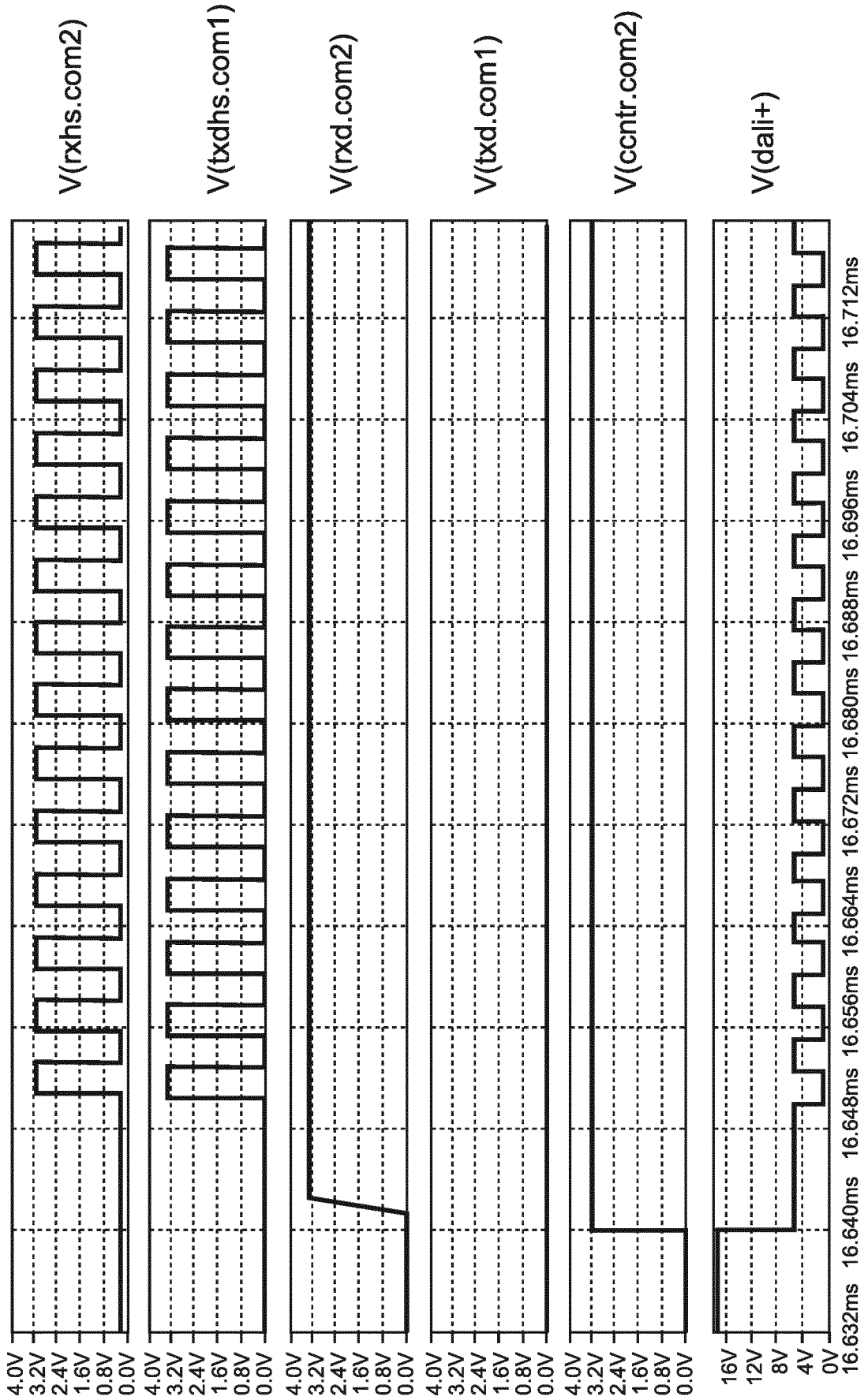
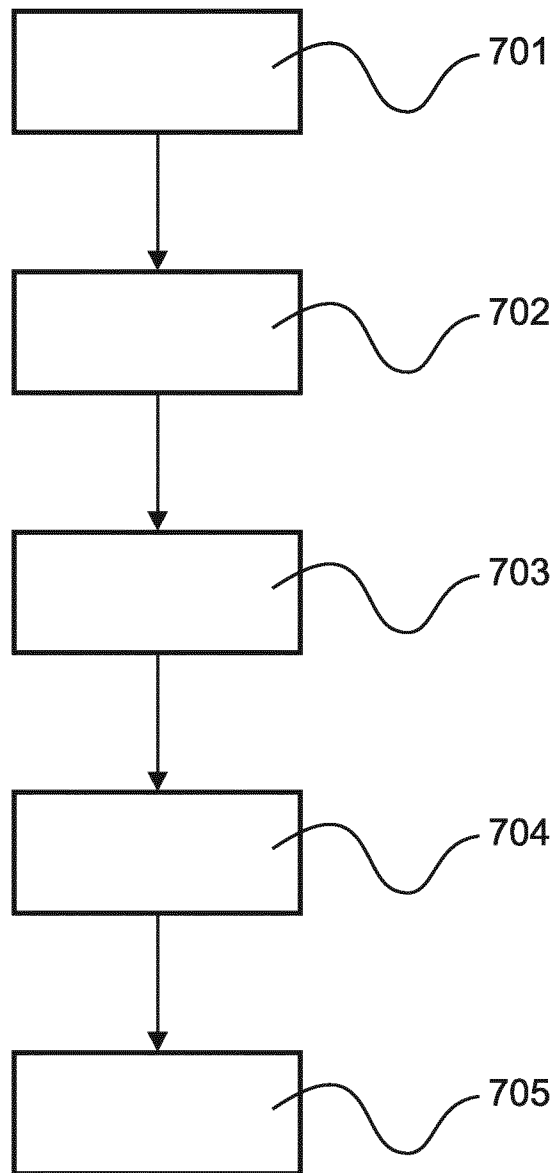

FIG. 6



**FIG. 7**

INTERNATIONAL SEARCH REPORT

International application No  
PCT/EP2018/058837

A. CLASSIFICATION OF SUBJECT MATTER  
INV. H05B37/02 H04L12/40  
ADD.  
According to International Patent Classification (IPC) or to both national classification and IPC

B. FIELDS SEARCHED  
Minimum documentation searched (classification system followed by classification symbols)  
H05B H04L

Documentation searched other than minimum documentation to the extent that such documents are included in the fields searched

Electronic data base consulted during the international search (name of data base and, where practicable, search terms used)  
EPO-Internal, WPI Data

C. DOCUMENTS CONSIDERED TO BE RELEVANT

Category*	Citation of document, with indication, where appropriate, of the relevant passages	Relevant to claim No.
Y	DE 10 2005 057309 A1 (BAYERISCHE MOTOREN WERKE AG [DE]) 14 June 2007 (2007-06-14) figures 1,2 paragraphs [0001], [0002] paragraphs [0010], [0011] paragraphs [0024] - [0026]	1-15
Y	US 2015/008842 A1 (HARBERS GERARD [US] ET AL) 8 January 2015 (2015-01-08) figures 5,8,9 paragraph [0037] paragraphs [0063] - [0068]	1-15
A	"DALI Manual", 1 November 2001 (2001-11-01), XP002224999, the whole document	1-15
	----- -/--	

Further documents are listed in the continuation of Box C.

See patent family annex.

\* Special categories of cited documents :

- "A" document defining the general state of the art which is not considered to be of particular relevance
- "E" earlier application or patent but published on or after the international filing date
- "L" document which may throw doubts on priority claim(s) or which is cited to establish the publication date of another citation or other special reason (as specified)
- "O" document referring to an oral disclosure, use, exhibition or other means
- "P" document published prior to the international filing date but later than the priority date claimed

- "T" later document published after the international filing date or priority date and not in conflict with the application but cited to understand the principle or theory underlying the invention
- "X" document of particular relevance; the claimed invention cannot be considered novel or cannot be considered to involve an inventive step when the document is taken alone
- "Y" document of particular relevance; the claimed invention cannot be considered to involve an inventive step when the document is combined with one or more other such documents, such combination being obvious to a person skilled in the art
- "&" document member of the same patent family

Date of the actual completion of the international search  22 May 2018	Date of mailing of the international search report  29/05/2018
Name and mailing address of the ISA/ European Patent Office, P.B. 5818 Patentlaan 2 NL - 2280 HV Rijswijk Tel. (+31-70) 340-2040, Fax: (+31-70) 340-3016	Authorized officer  Bonnet, Jérôme T.

## INTERNATIONAL SEARCH REPORT

International application No  
PCT/EP2018/058837

C(Continuation). DOCUMENTS CONSIDERED TO BE RELEVANT		
Category*	Citation of document, with indication, where appropriate, of the relevant passages	Relevant to claim No.
A	US 2016/242267 A1 (SCHEIDEGGER CARRE DENISE [US] ET AL) 18 August 2016 (2016-08-18) figures 4,5 paragraphs [0030] - [0038] -----	1-15

**INTERNATIONAL SEARCH REPORT**

Information on patent family members

International application No

PCT/EP2018/058837

Patent document cited in search report	Publication date	Patent family member(s)	Publication date
DE 102005057309 A1	14-06-2007	NONE	
-----			
US 2015008842 A1	08-01-2015	EP 3017662 A1	11-05-2016
		US 2015008842 A1	08-01-2015
		US 2017164453 A1	08-06-2017
		WO 2015002895 A1	08-01-2015
-----			
US 2016242267 A1	18-08-2016	US 2016242267 A1	18-08-2016
		WO 2016133584 A1	25-08-2016
-----			