



(51) International Patent Classification:
H04N 7/00 (2011.01)

(21) International Application Number:
PCT/US2013/055564

(22) International Filing Date:
19 August 2013 (19.08.2013)

(25) Filing Language: English

(26) Publication Language: English

(30) Priority Data:

61/702,650	18 September 2012 (18.09.2012)	US
61/736,692	13 December 2012 (13.12.2012)	US
61/798,821	15 March 2013 (15.03.2013)	US
61/805,053	25 March 2013 (25.03.2013)	US
61/804,942	25 March 2013 (25.03.2013)	US
61/804,998	25 March 2013 (25.03.2013)	US
61/805,027	25 March 2013 (25.03.2013)	US
61/805,042	25 March 2013 (25.03.2013)	US
61/805,003	25 March 2013 (25.03.2013)	US
61/804,971	25 March 2013 (25.03.2013)	US
61/805,038	25 March 2013 (25.03.2013)	US
61/804,990	25 March 2013 (25.03.2013)	US
61/805,030	25 March 2013 (25.03.2013)	US

(71) Applicant: FLEXTRONICS AP, LLC [US/US]; 6201 America Center Drive, San Jose, CA 95134 (US).

(72) Inventors: CSIKI, Robert; 131 Major Button's Drive, Markham, ON L3P 3X7 (CA). CASSAR, Ron; 165 Nicholson Court, Burlington, ON L7N 3N5 (CA). VISOSKY, John, S.; 11 Lady Diana Court, Gormley, ON L0H 1G0 (CA). SHOYKHER, Mikhail; 32 Bentoak Crescent, Thornhill, ON L4J8S5 (CA).

(74) Agent: AU, Yiu, F.; Sheridan Ross P.C., 1560 Broadway, Suite 1200, Denver, CO 80202 (US).

(81) Designated States (unless otherwise indicated, for every kind of national protection available): AE, AG, AL, AM, AO, AT, AU, AZ, BA, BB, BG, BH, BN, BR, BW, BY, BZ, CA, CH, CL, CN, CO, CR, CU, CZ, DE, DK, DM, DO, DZ, EC, EE, EG, ES, FI, GB, GD, GE, GH, GM, GT, HN, HR, HU, ID, IL, IN, IS, JP, KE, KG, KN, KP, KR, KZ, LA, LC, LK, LR, LS, LT, LU, LY, MA, MD, ME, MG, MK, MN, MW, MX, MY, MZ, NA, NG, NI, NO, NZ, OM, PA, PE, PG, PH, PL, PT, QA, RO, RS, RU, RW, SA, SC, SD, SE, SG, SK, SL, SM, ST, SV, SY, TH, TJ, TM, TN, TR, TT, TZ, UA, UG, US, UZ, VC, VN, ZA, ZM, ZW.

(84) Designated States (unless otherwise indicated, for every kind of regional protection available): ARIPO (BW, GH, GM, KE, LR, LS, MW, MZ, NA, RW, SD, SL, SZ, TZ, UG, ZM, ZW), Eurasian (AM, AZ, BY, KG, KZ, RU, TJ, TM), European (AL, AT, BE, BG, CH, CY, CZ, DE, DK, EE, ES, FI, FR, GB, GR, HR, HU, IE, IS, IT, LT, LU, LV,

[Continued on next page]

(54) Title: SOURCING EPG DATA

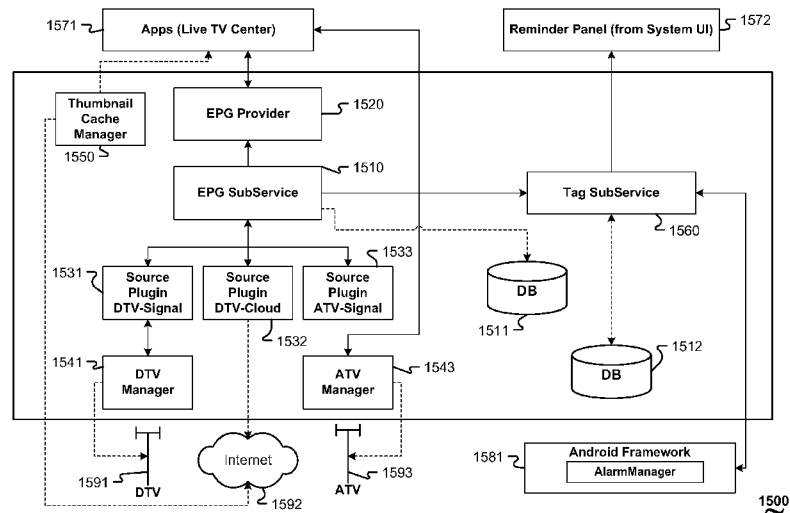

Fig. 15

(57) Abstract: An EPG data service for an Intelligent TV includes various of source plugins polling and retrieving updated EPG information from a plurality of respective EPG information sources and an EPG subservice receiving the EPG information retrieved by the various source plugins, aggregate the EPG information, and provide a relevant portion of the EPG information to an application of the Intelligent TV. For an EPG source with substantially no updated EPG information, the respective source plugin associates EPG information from the EPG source with dummy EPG data. The EPG subservice aggregates the updated EPG information from the plurality of EPG sources and resolve conflicts between duplicate EPG information from the plurality of EPG sources according to various rules.

WO 2014/046824 A1

MC, MK, MT, NL, NO, PL, PT, RO, RS, SE, SI, SK, **Published:**
SM, TR), OAPI (BF, BJ, CF, CG, CI, CM, GA, GN, GQ, — *with international search report (Art. 21(3))*
GW, KM, ML, MR, NE, SN, TD, TG).

SOURCING EPG DATA

CROSS REFERENCE TO RELATED APPLICATION

[0001] The present application claims the benefits of and priority, under 35 U.S.C. § 119(e), to U.S. Provisional Application Serial Nos. 61/684,672 filed August 17, 2012, “Smart TV”; 61/702,650 filed September 18, 2012, “Smart TV”; 61/697,710 filed September 6, 2012, “Social TV”; 61/700,182 filed September 12, 2012, “Social TV Roadmap”; 61/736,692 filed December 13, 2012, “SmartTV”; 61/798,821 filed March 15, 2013, “SmartTV”; 61/804,942 filed March 25, 2013, “SmartTV”; 61/804,998 filed March 25, 2013, “SmartTV”; 61/804,971 filed March 25, 2013, “SmartTV”; 61/804,990 filed March 25, 2013, “SmartTV”; 61/805,003 filed March 25, 2013, “SmartTV”; 61/805,053 filed March 25, 2013, “SmartTV”; 61/805,030 filed March 25, 2013, “SmartTV”; 61/805,027 filed March 25, 2013, “SmartTV”; 61/805,042 filed March 25, 2013, “SmartTV”; and 61/805,038 filed March 25, 2013, “SmartTV.” Each of the aforementioned documents is incorporated herein by reference in their entirety for all that they teach and for all purposes.

BACKGROUND

[0002] Consolidation of device features or technological convergence is in an increasing trend. Technological convergence describes the tendency for different technological systems to evolve toward performing similar tasks. As people use more devices, the need to carry those devices, charge those devices, update software on those devices, etc. becomes more cumbersome. To compensate for these problems, technology companies have been integrating features from different devices into one or two multi-functional devices. For example, cellular phones are now capable of accessing the Internet, taking photographs, providing calendar functions, etc.

[0003] The consolidation trend is now affecting the design and functionality of devices generally used in the home. For example, audio receivers can access the Internet, digital video recorders can store or provide access to digital photographs, etc. The television in home audio/video systems remains a cornerstone device because the display function cannot be integrated into other devices. As such, consolidating home devices leads to integrating features and functionality into the television. The emergence of the Smart Television (Smart TV) is evidence of the trend to consolidate functionality into the television.

[0004] A Smart TV is generally conceived as a device that integrates access to the Internet and Web 2.0 features into television sets. The Smart TV represents the trend of technological convergence between computers and television sets. The Smart TV generally focuses on

online interactive media, Internet TV, on-demand streaming media, and generally does not focus on traditional broadcast media. Unfortunately, most Smart TVs have yet to provide seamless and intuitive user interfaces for navigating and/or executing the various features of the Smart TV. As such, there are still issues with the consolidation of features and the presentation of these features in Smart TVs.

SUMMARY

[0005] There is a need for an Intelligent TV with intuitive user interfaces and with seamless user interaction capability. These and other needs are addressed by the various aspects, embodiments, and/or configurations of the present disclosure. Also, while the disclosure is presented in terms of exemplary embodiments, it should be appreciated that individual aspects of the disclosure can be separately claimed.

[0006] According to the disclosure, a method of managing EPG information for an Intelligent TV includes polling and retrieving a plurality of EPG sources for updated EPG information; aggregating the EPG information from the plurality of EPG sources; and providing a relevant portion of the EPG information to an application of the Intelligent TV. For an EPG source with substantially no updated EPG information, the polling and retrieving step includes associating the EPG information from the EPG source with dummy EPG data. The polling and retrieving step is activated by the Intelligent TV at a default or user-defined interval and after a channel scanning operation by the Intelligent TV. The polling and retrieving step comprises sending to an Internet or cloud EPG source a channel name list of the Intelligent TV and retrieving EPG information from the Internet or cloud EPG source that matches channels in the channel name list. The polling and retrieving step further includes retrieving EPG information for only selected programs and/or channels from the EPG sources. The aggregating step includes aggregating the updated EPG information from the plurality of EPG sources and resolving conflicts between duplicate EPG information from the plurality of EPG sources according to a plurality of rules. The resolving conflicts step comprises using EPG information from a first EPG source as a primary source and overwriting conflicting EPG information from the primary source with a second EPG source that is considered more reliable.

[0007] According to the disclosure, an EPG data service for an Intelligent TV includes a plurality of source plugins configured to poll and retrieve updated EPG information from a plurality of respective EPG information sources and an EPG subservice configured to receive the EPG information retrieved by the plurality of source plugins, aggregate the EPG

information, and provide a relevant portion of the EPG information to an application of the Intelligent TV.

[0008] According to the disclosure, an Intelligent TV includes an EPG display application configured to generate an EPG display for the Intelligent TV and an EPG data service, the EPG data service comprises a plurality of source plugins configured to poll and retrieve updated EPG information from a plurality of respective EPG information sources and an EPG subservice configured to receive the EPG information retrieved by the plurality of source plugins, aggregate the EPG information, and provide a relevant portion of the EPG information to the EPG display application.

[0009] The present disclosure can provide a number of advantages depending on the particular aspect, embodiment, and/or configuration.

[0010] These and other advantages will be apparent from the disclosure.

[0011] The phrases “at least one,” “one or more,” and “and/or” are open-ended expressions that are both conjunctive and disjunctive in operation. For example, each of the expressions “at least one of A, B and C,” “at least one of A, B, or C,” “one or more of A, B, and C,” “one or more of A, B, or C” and “A, B, and/or C” means A alone, B alone, C alone, A and B together, A and C together, B and C together, or A, B and C together.

[0012] The term “a” or “an” entity refers to one or more of that entity. As such, the terms “a” (or “an”), “one or more” and “at least one” can be used interchangeably herein. It is also to be noted that the terms “comprising,” “including,” and “having” can be used interchangeably.

[0013] The term “automatic” and variations thereof, as used herein, refers to any process or operation done without material human input when the process or operation is performed. However, a process or operation can be automatic, even though performance of the process or operation uses material or immaterial human input, if the input is received before performance of the process or operation. Human input is deemed to be material if such input influences how the process or operation will be performed. Human input that consents to the performance of the process or operation is not deemed to be “material.”

[0014] A “blog” (a blend of the term *web log*) is a type of website or part of a website supposed to be updated with new content from time to time. Blogs are usually maintained by an individual with regular entries of commentary, descriptions of events, or other material such as graphics or video. Entries are commonly displayed in reverse-chronological order.

[0015] A “blogging service” is a blog-publishing service that allows private or multi-user blogs with time-stamped entries.

[0016] The term “cable TV” refers to a system of distributing television programs to subscribers via radio frequency (RF) signals transmitted through coaxial cables or light pulses through fiber-optic cables. This contrasts with traditional broadcast television (terrestrial television) in which the television signal is transmitted over the air by radio waves and received by a television antenna attached to the television.

[0017] The term “channel” or “television channel,” as used herein, can be a physical or virtual channel over which a television station or television network is distributed. A physical channel in analog television can be an amount of bandwidth, typically 6, 7, or 8 MHz, that occupies a predetermined channel frequency. A virtual channel is a representation, in cable or satellite television, of a data stream for a particular television media provider (e.g., CDS, TNT, HBO, etc.).

[0018] The term “computer-readable medium,” as used herein, refers to any tangible storage and/or transmission medium that participate in providing instructions to a processor for execution. Such a medium may take many forms, including but not limited to, non-volatile media, volatile media, and transmission media. Non-volatile media includes, for example, NVRAM, or magnetic or optical disks. Volatile media includes dynamic memory, such as main memory. Common *forms* of computer-readable media include, for example, a floppy disk, a flexible disk, hard disk, magnetic tape, or any other magnetic medium, magneto-optical medium, a CD-ROM, any other optical medium, punch cards, paper tape, any other physical medium with patterns of holes, a RAM, a PROM, and EPROM, a FLASH-EPROM, a solid state medium like a memory card, any other memory chip or cartridge, a carrier wave as described hereinafter, or any other medium from which a computer can read. A digital file attachment to e-mail or other self-contained information archive or set of archives is considered a distribution medium equivalent to a tangible storage medium. When the computer-readable media is configured as a database, it is to be understood that the database may be any type of database, such as relational, hierarchical, object-oriented, and/or the like. Accordingly, the disclosure is considered to include a tangible storage medium or distribution medium and prior art-recognized equivalents and successor media, in which the software implementations of the present disclosure are stored.

[0019] The term “enhanced television” (ETV) refers to a collection of specifications developed under the OpenCable project of CableLabs (Cable Television Laboratories, Inc.) that define an ETV Application consisting of resources (files) adhering to the Enhanced TV Binary Interchange Format (EBIF) content format as well as PNG images, JPEG images, and PFR downloadable fonts. An ETV application is normally delivered through an MPEG

transport stream and accompanies an MPEG program containing video and audio elementary streams. An “ETV Application” is a collection of resources (files) that include one or more EBIF resources that represent viewable information in the form of pages. Two forms of a given ETV Application may be distinguished: (1) an interchange form and (2) an execution form. The interchange form of an ETV Application consists of the resources (files) that represent the compiled application prior to its actual execution by an ETV User Agent. The execution form of an ETV Application consists of the stored, and possibly mutated forms of these resources while being decoded, presented, and executed by an ETV User Agent. An “ETV User Agent” is a software component that operates on a set-top box, a television, or any other computing environment capable of receiving, decoding, presenting, and processing an ETV Application. This component usually provides, along with its host hardware environment, one or more mechanisms for an end-user to navigate and interact with the multimedia content represented by ETV Applications.

[0020] The term “high-definition television” (HDTV) provides a resolution that is substantially higher than that of standard-definition television. HDTV may be transmitted in various formats, namely 1080p - 1920×1080p: 2,073,600 pixels (approximately 2.1 megapixels) per frame, 1080i (which is typically either 1920×1080i: 1,036,800 pixels (approximately 1 megapixel) per field or 2,073,600 pixels (approximately 2.1 megapixels) per frame or 1440×1080i:[1] 777,600 pixels (approximately 0.8 megapixels) per field or 1,555,200 pixels (approximately 1.6 megapixels) per frame), or 720p - 1280×720p: 921,600 pixels (approximately 0.9 megapixels) per frame. As will be appreciated, “frame size” in pixels is defined as number of horizontal pixels × number of vertical pixels, for example 1280 × 720 or 1920 × 1080. Often the number of horizontal pixels is implied from context and is omitted, as in the case of 720p and 1080p, “scanning system” is identified with the letter “p” for progressive scanning or “i” for interlaced scanning, and “frame rate” is identified as number of video frames per second. For interlaced systems an alternative form of specifying number of fields per second is often used. For purposes of this disclosure, “high-definition television” is deemed to include other high-definition analog or digital video formats, including ultra high definition television.

[0021] The term “internet television” (otherwise known as Internet TV, Online Television, or Online TV) is the digital distribution of television content via the Internet. It should not be confused with Web television - short programs or videos created by a wide variety of companies and individuals, or Internet protocol television (IPTV) - an emerging internet technology standard for use by television broadcasters. Internet Television is a general term

that covers the delivery of television shows and other video content over the internet by video streaming technology, typically by major traditional television broadcasters. It does not describe a technology used to deliver content (see Internet protocol television). Internet television has become very popular through services such as RTÉ Player in Ireland; BBC iPlayer, 4oD, ITV Player (also STV Player and UTV Player) and Demand Five in the United Kingdom; Hulu in the United States; Nederland 24 in the Netherlands; ABC iview and Australia Live TV in Australia; Tivibu in Turkey; and iWanTV! in the Philippines.

[0022] The term “internet protocol television” (IPTV) refers to a system through which television services are delivered using the Internet protocol suite over a packet-switched network such as the Internet, instead of being delivered through traditional terrestrial, satellite signal, and cable television formats. IPTV services may be classified into three main groups, namely live television, with or without interactivity related to the current TV show; time-shifted television: catch-up TV (replays a TV show that was broadcast hours or days ago), start-over TV (replays the current TV show from its beginning); and video on demand (VOD): browse a catalog of videos, not related to TV programming. IPTV is distinguished from Internet television by its on-going standardization process (e.g., European Telecommunications Standards Institute) and preferential deployment scenarios in subscriber-based telecommunications networks with high-speed access channels into end-user premises via set-top boxes or other customer-premises equipment.

[0023] The term “silo,” as used herein, can be a logical representation of an input, source, or application. An input can be a device or devices (e.g., DVD, VCR, etc.) electrically connected to the television through a port (e.g., HDMI, video/audio inputs, etc.) or through a network (e.g., LAN WAN, etc.). Rather than a device or devices, the input could be configured as an electrical or physical connection to one or more devices. A source, particularly a content source, can be a data service that provides content (e.g., a media center, a file system, etc.). An application can be a software service that provides a particular type of function (e.g., Live TV, Video on Demand, User Applications, photograph display, etc.). The silo, as a logical representation, can have an associated definition or property, such as a setting, feature, or other characteristic.

[0024] The term “panel,” as used herein, can mean a user interface displayed in at least a portion of the display. The panel may be interactive (e.g., accepts user input) or informational (e.g., does not accept user input). A panel may be translucent whereby the panel obscures but does not mask the underlying content being displayed in the display. Panels may be provided in response to a user input from a button or remote control interface.

[0025] The term “screen,” as used herein, refers to a physical structure that includes one or more hardware components that provide the device with the ability to render a user interface and/or receive user input. A screen can encompass any combination of gesture capture region, a touch sensitive display, and/or a configurable area. The device can have one or more physical screens embedded in the hardware. However a screen may also include an external peripheral device that may be attached and detached from the device. In embodiments, multiple external devices may be attached to the device. For example, another screen may be included with a remote control unit that interfaces with the Intelligent TV.

[0026] The term “media” or “multimedia,” as used herein, refers to content that may assume one of a combination of different content forms. Multimedia can include one or more of, but is not limited to, text, audio, still images, animation, video, or interactivity content forms.

[0027] The term “Intelligent TV,” as used herein, refers to a television configured to provide one or more intuitive user interfaces and interactions based on a unique application platform and architecture. The Intelligent TV utilizes processing resources associated with the television to integrate Internet connectivity with parallel application functionality. This integration allows a user the ability to intuitively access various sources of media and content (e.g., Internet, over-the-top content, on-demand streaming media, over-the-air broadcast media, and/or other forms of information) via the Intelligent TV in a quick and efficient manner. Although the Intelligent TV disclosed herein may comprise one or more components of a “smart TV,” it is an aspect of the Intelligent TV to provide expanded intuitive user interaction capability for navigating and executing the various features of the television. A “smart TV,” sometimes referred to as a connected TV, or hybrid TV (not to be confused with IPTV, Internet TV, or with Web TV), describes a trend of integration of the Internet and Web 2.0 features into television sets and set-top boxes, as well as the technological convergence between computers and these television sets/set-top boxes. The smart TV devices have a higher focus on online interactive media, Internet TV, over-the-top content, as well as on-demand streaming media, and less focus on traditional broadcast media than traditional television sets and set-top boxes. As can be appreciated, the Intelligent TV encompasses a broader range of technology than that of the smart TV defined above.

[0028] The term “television” is a telecommunication medium, device (or set) or set of associated devices, programming, and/or transmission for transmitting and receiving moving images that can be monochrome (black-and-white) or colored, with or without accompanying sound. Different countries use one of the three main video standards for TVs, namely PAL,

NTSC or SECAM. Television is most commonly used for displaying broadcast television signals. The broadcast television system is typically disseminated via radio transmissions on designated channels in the 54–890 MHz frequency band. A common television set comprises multiple internal electronic circuits, including those for receiving and decoding broadcast signals. A visual display device which lacks a tuner is properly called a video monitor, rather than a television. A television may be different from other monitors or displays based on the distance maintained between the user and the television when the user watches the media and based on the inclusion of a tuner or other electronic circuit to receive the broadcast television signal.

[0029] The term “Live TV,” as used herein, refers to a television production broadcast in real-time, as events happen, in the present.

[0030] The term “standard-definition television” (SDTV) is a television system that uses a resolution that is not considered to be either high-definition television (HDTV 720p and 1080p) or enhanced-definition television (EDTV 480p). The two common SDTV signal types are 576i, with 576 interlaced lines of resolution, derived from the European-developed PAL and SECAM systems; and 480i based on the American National Television System Committee NTSC system. In the US, digital SDTV is broadcast in the same 4:3 aspect ratio as NTSC signals. However, in other parts of the world that used the PAL or SECAM analog standards, standard-definition television is now usually shown with a 16:9 aspect ratio. Standards that support digital SDTV broadcast include DVB, ATSC and ISDB. Television signals are transmitted in digital form, and their pixels have a rectangular shape, as opposed to square pixels that are used in modern computer monitors and modern implementations of HDTV. The table below summarizes pixel aspect ratios for various kinds of SDTV video signal. Note that the actual image (be it 4:3 or 16:9) is always contained in the center 704 horizontal pixels of the digital frame, regardless of how many horizontal pixels (704 or 720) are used. In case of digital video signal having 720 horizontal pixels, only the center 704 pixels contain actual 4:3 or 16:9 image, and the 8 pixel wide stripes from either side are called nominal analogue blanking and should be discarded before displaying the image. Nominal analogue blanking should not be confused with overscan, as overscan areas are part of the actual 4:3 or 16:9 image.

[0031] The term “video on demand (VOD),” as used herein, refers to systems and processes which allow users to select and watch/listen to video or audio content on demand. VOD systems may stream content, to view the content in real time, or download the content to a storage medium for viewing at a later time.

[0032] The term “satellite positioning system receiver” refers to a wireless receiver or transceiver to receive and/or send location signals from and/or to a satellite positioning system, such as the Global Positioning System (GPS) (US), GLONASS (Russia), Galileo positioning system (EU), Compass navigation system (China), and Regional Navigational Satellite System (India).

[0033] The term “display,” as used herein, refers to at least a portion of a screen used to display the output of the television to a user. A display may be a single-screen display or a multi-screen display, referred to as a composite display. A composite display can encompass the touch sensitive display of one or more screens. A single physical screen can include multiple displays that are managed as separate logical displays. Thus, different content can be displayed on the separate displays although part of the same physical screen.

[0034] The term “displayed image,” as used herein, refers to an image produced on the display. A typical displayed image is a television broadcast or menu. The displayed image may occupy all or a portion of the display.

[0035] The term “display orientation,” as used herein, refers to the way in which a rectangular display is oriented by a user for viewing. The two most common types of display orientation are portrait and landscape. In landscape mode, the display is oriented such that the width of the display is greater than the height of the display (such as a 4:3 ratio, which is 4 units wide and 3 units tall, or a 16:9 ratio, which is 16 units wide and 9 units tall). Stated differently, the longer dimension of the display is oriented substantially horizontal in landscape mode while the shorter dimension of the display is oriented substantially vertical. In the portrait mode, by contrast, the display is oriented such that the width of the display is less than the height of the display. Stated differently, the shorter dimension of the display is oriented substantially horizontal in the portrait mode while the longer dimension of the display is oriented substantially vertical.

[0036] The term “module,” as used herein, refers to any known or later developed hardware, software, firmware, artificial intelligence, fuzzy logic, or combination of hardware and software that is capable of performing the functionality associated with that element.

[0037] The terms “determine,” “calculate” and “compute,” and variations thereof, as used herein, are used interchangeably and include any type of methodology, process, mathematical operation or technique.

[0038] The term “touch screen” or “touchscreen” refer to screen that can receive user contact or other tactile input, such as a stylus. The touch screen may sense user contact in a number of different ways, such as by a change in an electrical parameter (e.g., resistance or

capacitance), acoustic wave variations, infrared radiation proximity detection, light variation detection, and the like. In a resistive touch screen, for example, normally separated conductive and resistive metallic layers in the screen pass an electrical current. When a user touches the screen, the two layers make contact in the contacted location, whereby a change in electrical field is noted and the coordinates of the contacted location calculated. In a capacitive touch screen, a capacitive layer stores electrical charge, which is discharged to the user upon contact with the touch screen, causing a decrease in the charge of the capacitive layer. The decrease is measured, and the contacted location coordinates determined. In a surface acoustic wave touch screen, an acoustic wave is transmitted through the screen, and the acoustic wave is disturbed by user contact. A receiving transducer detects the user contact instance and determines the contacted location coordinates.

[0039] The term “web television” is original television content produced for broadcast via the World Wide Web. Some major distributors of web television are YouTube, Myspace, Newgrounds, Blip.tv, and Crackle.

[0040] The terms “instant message” and “instant messaging” refer to a form of real-time text communication between two or more people, typically based on typed text.

[0041] The term “internet search engine” refers to a web search engine designed to search for information on the World Wide Web and FTP servers. The search results are generally presented in a list of results often referred to as SERPS, or “search engine results pages”. The information may consist of web pages, images, information and other types of files. Some search engines also mine data available in databases or open directories. Web search engines work by storing information about many web pages, which they retrieve from the html itself. These pages are retrieved by a Web crawler (sometimes also known as a spider) — an automated Web browser which follows every link on the site. The contents of each page are then analyzed to determine how it should be indexed (for example, words are extracted from the titles, headings, or special fields called meta tags). Data about web pages are stored in an index database for use in later queries. Some search engines, such as Google™, store all or part of the source page (referred to as a cache) as well as information about the web pages, whereas others, such as AltaVista™, store every word of every page they find.

[0042] The terms “online community,” “e-community,” or “virtual community” mean a group of people that primarily interact via a computer network, rather than face to face, for social, professional, educational or other purposes. The interaction can use a variety of media formats, including wikis, blogs, chat rooms, Internet forums, instant messaging, email, and

other forms of electronic media. Many media formats are used in social software separately or in combination, including text-based chatrooms and forums that use voice, video text or avatars.

[0043] The term “remote control” refers to a component of an electronics device, most commonly a television set, DVD player and/or home theater system for operating the device wirelessly, typically from a short line-of-sight distance. Remote control normally uses infrared and/or radio frequency (RF) signaling and can include WiFi, wireless USB, Bluetooth™ connectivity, motion sensor enabled capabilities and/or voice control. A touchscreen remote control is a handheld remote control device which uses a touchscreen user interface to replace most of the hard, built-in physical buttons used in normal remote control devices.

[0044] The term “satellite TV” refers to television programming delivered by the means of communications satellites and received by an outdoor antenna, usually a parabolic reflector generally referred to as a satellite dish, and as far as household usage is concerned, a satellite receiver either in the form of an external set-top box or a satellite tuner module built into a TV set.

[0045] The term “social network service” is a service provider that builds online communities of people, who share interests and/or activities, or who are interested in exploring the interests and activities of others. Most social network services are web-based and provide a variety of ways for users to interact, such as e-mail and instant messaging services.

[0046] The term “social network” refers to a web-based social network.

[0047] The term “gesture” refers to a user action that expresses an intended idea, action, meaning, result, and/or outcome. The user action can include manipulating a device (e.g., opening or closing a device, changing a device orientation, moving a trackball or wheel, etc.), movement of a body part in relation to the device, movement of an implement or tool in relation to the device, audio inputs, etc. A gesture may be made on a device (such as on the screen) or with the device to interact with the device.

[0048] The term “gesture capture” refers to a sense or otherwise a detection of an instance and/or type of user gesture. The gesture capture can occur in one or more areas of the screen. A gesture region can be on the display, where it may be referred to as a touch sensitive display or off the display where it may be referred to as a gesture capture area.

[0049] The term “electronic address” refers to any contactable address, including a telephone number, instant message handle, e-mail address, Universal Resource Locator

(URL), Universal Resource Identifier (URI), Address of Record (AOR), electronic alias in a database, like addresses, and combinations thereof.

[0050] It shall be understood that the term “means,” as used herein, shall be given its broadest possible interpretation in accordance with 35 U.S.C., Section 112(f). Accordingly, a claim incorporating the term “means” shall cover all structures, materials, or acts set forth herein, and all of the equivalents thereof. Further, the structures, materials or acts and the equivalents thereof shall include all those described in the summary of the invention, brief description of the drawings, detailed description, abstract, and claims themselves.

[0051] The preceding is a simplified summary of the disclosure to provide an understanding of some aspects of the disclosure. This summary is neither an extensive nor exhaustive overview of the disclosure and its various aspects, embodiments, and/or configurations. It is intended neither to identify key or critical elements of the disclosure nor to delineate the scope of the disclosure but to present selected concepts of the disclosure in a simplified form as an introduction to the more detailed description presented below. As will be appreciated, other aspects, embodiments, and/or configurations of the disclosure are possible utilizing, alone or in combination, one or more of the features set forth above or described in detail below.

BRIEF DESCRIPTION OF THE DRAWINGS

[0052] Fig. 1A includes a first view of an embodiment of an environment of an Intelligent television;

[0053] Fig. 1B includes a second view of an embodiment of an environment of an Intelligent television;

[0054] Fig. 2A includes a first view of an embodiment of an Intelligent television;

[0055] Fig. 2B includes a second view of an embodiment of an Intelligent television;

[0056] Fig. 2C includes a third view of an embodiment of an Intelligent television;

[0057] Fig. 2D includes a fourth view of an embodiment of an Intelligent television;

[0058] Fig. 3 is a block diagram of an embodiment of the hardware of an Intelligent television;

[0059] Fig. 4 is a block diagram of an embodiment of the Intelligent television software and/or firmware;

[0060] Fig. 5 is a second block diagram of an embodiment of the Intelligent television software and/or firmware;

[0061] Fig. 6 is a third block diagram of an embodiment of the Intelligent television software and/or firmware;

- [0062] Fig. 7 is a plan view of an embodiment of a handheld remote control;
- [0063] Fig. 8 is a side view of an embodiment of a remote control;
- [0064] Fig. 9A is a bottom view of an embodiment of a remote control with a joystick in a neutral position;
- [0065] Fig. 9B is a bottom view of an embodiment of a remote control with the joystick in a lower position;
- [0066] Fig. 9C is a bottom view of an embodiment of a remote control with the joystick in an upper position;
- [0067] Fig. 10 is a plan view of another embodiment of a handheld remote control;
- [0068] Fig. 11A is a front view of an embodiment of an Intelligent TV screen;
- [0069] Fig. 11B is a front view of an embodiment of an Intelligent TV screen;
- [0070] Fig. 11C is a front view of an embodiment of an Intelligent TV screen;
- [0071] Fig. 12 is a block diagram of an embodiment of a handheld remote control of either Fig. 7 or 10;
- [0072] Fig. 13 is a block diagram of an embodiment of a content data service;
- [0073] Fig. 14 is a block diagram of an embodiment of a data service;
- [0074] Fig. 15 is a flow diagram of an embodiment of a data management process; and
- [0075] Fig. 16 is a flow diagram of an EPG management process.
- [0076] In the appended figures, similar components and/or features may have the same reference label. Further, various components of the same type may be distinguished by following the reference label by a letter that distinguishes among the similar components. If only the first reference label is used in the specification, the description is applicable to any one of the similar components having the same first reference label irrespective of the second reference label.

DETAILED DESCRIPTION

[0077] Presented herein are embodiments of a device. The device can be a network-enabled telecommunications device, such as a television, an electronic visual display device, or other smart device. The device can include one or more screens, or sections of a screen, that are configured to receive and present information from a number of sources. Further, the device can receive user input in unique ways. The overall design and functionality of the device provides for an enhanced user experience making the device more useful and more efficient.

[0078] Intelligent Television (TV) Environment:

[0079] Referring to Figs. 1A and 1B, an Intelligent TV, or device, 100 is shown. It is anticipated that the Intelligent TV 100 may be used for entertainment, business applications, social interaction, content creation and/or consumption, and to organize and control one or more other devices that are in communication with the Intelligent TV 100. As can be appreciated, the Intelligent TV 100 can be used to enhance the user interactive experience whether at home or at work.

[0080] In some embodiments, the Intelligent TV 100 may be configured to receive and understand a variety of user and/or device inputs. For example, a user may interface with the Intelligent TV 100 via one or more physical or electrical controls, such as buttons, switches, touch sensitive screens/regions (e.g., capacitive touch, resistive touch, etc.), and/or other controls associated with the Intelligent TV 100. In some cases, the Intelligent TV 100 may include the one or more interactive controls. Additionally or alternatively, the one or more controls may be associated with a remote control. The remote control may communicate with the Intelligent TV 100 via wired and/or wireless signals. As can be appreciated, the remote control may operate via radio frequency (RF), infrared (IR), and/or a specific wireless communications protocol (e.g., Bluetooth™, Wi-Fi, etc.). In some cases, the controls, whether physical or electrical, may be configured (e.g., programmed) to suit a user's preferences.

[0081] Additionally or alternatively, smart phones, tablets, computers, laptops, netbooks, and other smart devices may be used to control the Intelligent TV 100. For example, control of the Intelligent TV 100 may be achieved via an application running on a smart device. The application may be configured to present a user with various Intelligent TV 100 controls in an intuitive user interface (UI) on a screen associated with the device 100. The screen may be a touch sensitive, or touch screen, display. Selections input by a user via the UI may be configured to control the Intelligent TV 100 by the application accessing one or more communication features associated with the smart device.

[0082] It is anticipated that the Intelligent TV 100 can receive input via various input devices including, but in no way limited to, video, audio, radio, light, tactile, and combinations thereof. Among other things, these input devices may be configured to allow the Intelligent TV 100 to see, recognize, and react to user gestures. For instance, a user may talk to the Intelligent TV 100 in a conversational manner. The Intelligent TV 100 may hear and understand voice commands in a manner similar to a smart device's Intelligent personal assistant and voice-controlled navigator application (e.g., Apple's Siri, Android's Skyvi, Robin, Iris, and other applications).

[0083] The Intelligent TV 100 may also be a communications device which can establish network connections 104 through many alternate means, including wired 108 or wireless 112 means, over cellular networks 116 to connect via cellular base antenna 142 to telephone networks operated by telephone company 146, and by using a telephone line 120 to connect to telephone networks operated by telephone company 146. These connections 104 enable the Intelligent TV 100 to access one or more communication networks 132. The communication networks may comprise any type of known communication medium or collection of communication media and may use any type of protocols to transport messages or signals between endpoints. The communication networks may include wired and/or wireless communication technologies. The Internet is an example of a communication network 132 that constitutes an Internet Protocol (IP) network consisting of many computers, computing networks, and other communication devices located all over the world, which are connected through many telephone systems and other means.

[0084] Other examples of the communication network 132 include, without limitation, a standard Plain Old Telephone System (POTS), an Integrated Services Digital Network (ISDN), the Public Switched Telephone Network (PSTN), a Local Area Network (LAN), a Wide Area Network (WAN), a cellular network, and any other type of packet-switched or circuit-switched network known in the art. In addition, it can be appreciated that the communication network 132 need not be limited to any one network type, and instead may be comprised of a number of different networks and/or network types.

[0085] In some embodiments, the Intelligent TV 100 may be equipped with multiple communication means. The multiple communication means may allow the Intelligent TV 100 to communicate across Local Area Networks (LANs) 124, wireless local area networks (WLANs) 128, and other networks 132. The networks 132 may be connected in a redundant manner to ensure network access. In other words, if one connection is interrupted, the Intelligent TV 100 can use an alternate communications path to reestablish and/or maintain the network connection 104. Among other things, the Intelligent TV 100 may use these network connections 104 to send and receive information, interact with an electronic program guide (EPG) 136, receive software updates 140, contact customer service 144 (e.g., to receive help or service, etc.), and/or access remotely stored digital media libraries 148. In addition, these connections can allow the Intelligent TV 100 to make phone calls, send and/or receive email messages, send and/or receive text messages (such as email and instant messages), surf the Internet using an internet search engine, post blogs by a blogging service, and connect/interact with social media sites and/or an online community (e.g., Facebook™,

Twitter™, LinkedIn™, Pinterest™, Google+™, MySpace™, and the like) maintained by a social network service. In combination with other components of the Intelligent TV 100 described in more detail below, these network connections 104 also enable the Intelligent TV 100 to conduct video teleconferences, electronic meetings, and other communications. The Intelligent TV 100 may capture and store images and sound, using associated cameras, microphones, and other sensors. Additionally or alternatively, the Intelligent TV 100 may create and save screen shots of media, images, and data displayed on a screen associated with the Intelligent TV 100.

[0086] Further, as shown in Fig. 1B, the Intelligent TV 100 can interact with other electronic devices 168 by either by the wired 108 and/or wireless 112 connections. As described herein, components of the Intelligent TV 100 allow the device 100 to be connected to devices 168 including, but not limited to, DVD players 168a, BluRay players 168b, portable digital media devices 168c, smart phones 168d, tablet devices 168e, personal computers 168f, external cable boxes 168g, keyboards 168h, pointing devices 168i, printers 168j, game controllers and/or game pads 168k, satellite dishes 168l, external display devices 168m, and other universal serial bus (USB), local area network (LAN), Bluetooth™, or high-definition multimedia interface (HDMI) compliant devices, and/or wireless devices. When connected to an external cable box 168g or satellite dish 168l, the Intelligent TV 100 can access additional media content. Also, as further described below, the Intelligent TV 100 is capable of receiving digital and/or analog signals broadcast by TV stations. The Intelligent TV 100 can be configured as one or more of a standard-definition television, enhanced television, and high-definition television. It may operate as one or more of cable, Internet, Internet Protocol, satellite, web, and/or smart television. The Intelligent TV 100 may also be used to control the operation of, and may interface with, other smart components such as security systems 172, door/gate controllers 176, remote video cameras 180, lighting systems 184, thermostats 188, refrigerators 192, and other appliances.

[0087] Intelligent TV:

[0088] Figs. 2A-2D illustrate components of the Intelligent TV 100. In general, as shown by Fig. 2A, the Intelligent TV 100 can be supported by a removable base or stand 204 that is attached to a frame 208. The frame 208 surrounds edges of a display screen 212, leaving a front surface of the display screen 212 uncovered. The display screen 212 may comprise a Liquid Crystal Display (LCD) screen, a plasma screen, Light Emitting Diode (LED) screen, or other screen types. In embodiments, the entire front surface of the screen 212 may be

touch sensitive and capable of receiving input by the user touching the front surface of the screen 212.

[0089] The Intelligent TV 100 may include integrated speakers 216 and at least one microphone 220. A first area of the frame 208 may comprise a horizontal gesture capture region 224 and second areas comprise vertical gesture capture regions 228. The gesture capture regions 224, 228 may comprise areas or regions that are capable of receiving input by recognizing gestures made by the user, and in some examples, without the need for the user to actually touch the screen 212 surface of the Intelligent TV 100. However, the gesture capture regions 224, 228 may not include pixels that can perform a display function or capability.

[0090] One or more image capture devices 232, such as a camera, can be included for capturing still and/or video images. The image capture device 232 can include or be associated with additional elements, such as a flash or other light source 236 and a range finding device 240 to assist focusing of the image capture device. In addition, the microphone 220, gesture capture regions 224, 228, image capture devices 232, and the range finding device 240 may be used by the Intelligent TV 100 to recognize individual users. Additionally or alternatively, the Intelligent TV 100 may learn and remember preferences associated with the individual users. In some embodiments, the learning and remembering (i.e., identifying and recalling stored information) may be associated with the recognition of a user.

[0091] An IR transmitter and receiver 244 may also be provided to connect the Intelligent TV 100 with a remote control device (not shown) or other IR devices. Additionally or alternatively, the remote control device may transmit wireless signals via RF, light, and/or a means other than IR. Also shown in Fig. 2A is an audio jack 248, which may be hidden behind a panel that is hinged or removable. The audio jack 248 accommodates a tip, ring, sleeve (TRS) connector, for example, to allow the user to utilize headphones, a headset, or other external audio equipment.

[0092] The Intelligent TV 100 can also include a number of buttons 252. For example, Fig. 2A illustrates the buttons 252 on the top of the Intelligent TV 100, although the buttons could be placed at other locations. As shown, the Intelligent TV 100 includes six buttons 252a-f, which can be configured for specific inputs. For example, the first button 252a may be configured as an on/off button used to control overall system power to the Intelligent TV 100. The buttons 252 may be configured to, in combination or alone, control a number of aspects of the Intelligent TV 100. Some non-limiting examples include, but are not limited to,

overall system volume, brightness, the image capture device, the microphone, and initiation/termination of a video conference. Instead of separate buttons, two of the buttons may be combined into a rocker button. This rocker button arrangement may be useful in situations where the buttons are configured to control features such as volume or brightness. In some embodiments, one or more of the buttons 252 are capable of supporting different user commands. By way of example, a normal press has a duration commonly of less than about 1 second and resembles a quick input. A medium press has a duration commonly of 1 second or more but less than about 12 seconds. A long press has a duration commonly of about 12 seconds or more. The function of the buttons is normally specific to the application that is active on the Intelligent TV 100. In the video conference application for instance and depending on the particular button, a normal, medium, or long press can mean end the video conference, increase or decrease the volume, increase a rate speed associated with a response to an input, and toggle microphone mute. Depending on the particular button, a normal, medium, or long press can also control the image capture device 232 to increase zoom, decrease zoom, take a photograph, or record video.

[0093] In support of communications functions or capabilities, the Intelligent TV 100 can include one or more shared or dedicated antennae 256 and wired broadband connections 260 as shown in Fig. 2B. The antennae 256 also enable the Intelligent TV 100 to receive digital and/or analog broadcast TV channels. The wired broadband connections 260 are, for example, a Digital Subscriber Line (DSL), an optical line, an Ethernet port, an IEEE 1394 interface, or other interfaces. The Intelligent TV 100 also has a telephone line jack 262 to further provide communications capability.

[0094] In addition to the removable base 204, the Intelligent TV 100 may include hardware and mounting points 264 on a rear surface to facilitate mounting the Intelligent TV 100 to a surface, such as a wall. In one example, the Intelligent TV 100 may incorporate at least one Video Equipment Standards Association (VESA) mounting interface for attaching the device 100 to the surface.

[0095] As shown in Fig. 2C, the Intelligent TV 100 may include docking interfaces or ports 268. The docking ports 268 may include proprietary or universal ports to support the interconnection of the Intelligent TV 100 to other devices or components, which may or may not include additional or different capabilities from those integral to the Intelligent TV 100. In addition to supporting an exchange of communication signals between the Intelligent TV 100 and a connected device or component, the docking ports 268 can support the supply of power to the connected device or component. The docking ports 268 can also comprise an

Intelligent element that comprises a docking module for controlling communications or other interactions between the Intelligent TV 100 and the connected device or component.

[0096] The Intelligent TV 100 also includes a number of card slots 272 and network or peripheral interface ports 276. The card slots 272 may accommodate different types of cards including subscriber identity modules (SIM), secure digital (SD) cards, MiniSD cards, flash memory cards, and other cards. Ports 276 in embodiments may include input/output (I/O) ports, such as universal serial bus (USB) ports, parallel ports, game ports, and high-definition multimedia interface (HDMI) connectors.

[0097] An audio/video (A/V) I/O module 280 can be included to provide audio to an interconnected speaker or other device, and to receive audio input from a connected microphone or other device. As an example, the audio input/output interface 280 may comprise an associated amplifier and analog-to-digital converter.

[0098] Hardware Features:

[0099] Fig. 3 illustrates components of an Intelligent TV 100 in accordance with embodiments of the present disclosure. In general, the Intelligent TV 100 includes a primary screen 304. Screen 304 can be a touch sensitive screen and can include different operative areas.

[00100] For example, a first operative area, within the screen 304, may comprise a display 310. In some embodiments, the display 310 may be touch sensitive. In general, the display 310 may comprise a full color, display.

[00101] A second area within the screen 304 may comprise a gesture capture region 320. The gesture capture region 320 may comprise an area or region that is outside of the display 310 area, and that is capable of receiving input, for example in the form of gestures provided by a user. However, the gesture capture region 320 does not include pixels that can perform a display function or capability.

[00102] A third region of the screen 304 may comprise a configurable area 312. The configurable area 312 is capable of receiving input and has display or limited display capabilities. In embodiments, the configurable area 312 may present different input options to the user. For example, the configurable area 312 may display buttons or other relatable items. Moreover, the identity of displayed buttons, or whether any buttons are displayed at all within the configurable area 312 of a screen 304, may be determined from the context in which the Intelligent TV 100 is used and/or operated.

[0100] In an exemplary touch sensitive screen 304 embodiment, the touch sensitive screen 304 comprises a liquid crystal display extending across at least those regions of the touch

sensitive screen 304 that are capable of providing visual output to a user, and a capacitive input matrix over those regions of the touch sensitive screen 304 that are capable of receiving input from the user.

[0101] One or more display controllers 316 may be provided for controlling the operation of the screen 304. The display controller 316 may control the operation of the touch sensitive screen 304, including input (touch sensing) and output (display) functions. The display controller 316 may also control the operation of the screen 304 and may interface with other inputs, such as infrared and/or radio input signals (e.g., door/gate controllers, alarm system components, etc.). In accordance with still other embodiments, the functions of a display controller 316 may be incorporated into other components, such as a processor 364.

[0102] The processor 364 may comprise a general purpose programmable processor or controller for executing application programming or instructions. In accordance with at least some embodiments, the processor 364 may include multiple processor cores, and/or implement multiple virtual processors. In accordance with still other embodiments, the processor 364 may include multiple physical processors. As a particular example, the processor 364 may comprise a specially configured application specific integrated circuit (ASIC) or other integrated circuit, a digital signal processor, a controller, a hardwired electronic or logic circuit, a programmable logic device or gate array, a special purpose computer, or the like. The processor 364 generally functions to run programming code or instructions implementing various functions of the Intelligent TV 100.

[0103] In support of connectivity functions or capabilities, the Intelligent TV 100 can include a module for encoding/decoding and/or compression/decompression 366 for receiving and managing digital television information. Encoding/decoding compression/decompression module 366 enables decompression and/or decoding of analog and/or digital information dispatched by a public television chain or in a private television network and received across antenna 324, I/O module 348, wireless connectivity module 328, and/or other wireless communications module 332. The television information may be sent to screen 304 and/or attached speakers receiving analog or digital reception signals. Any encoding/decoding and compression/decompression is performable on the basis of various formats (e.g., audio, video, and data). Encrypting module 368 is in communication with encoding/decoding compression/decompression module 366 and enables the confidentiality of all the data received or transmitted by the user or supplier.

[0104] In support of communications functions or capabilities, the Intelligent TV 100 can include a wireless connectivity module 328. As examples, the wireless connectivity module

328 can comprise a GSM, CDMA, FDMA and/or analog cellular telephony transceiver capable of supporting voice, multimedia and/or data transfers over a cellular network. Alternatively or in addition, the Intelligent TV 100 can include an additional or other wireless communications module 332. As examples, the other wireless communications module 332 can comprise a Wi-Fi, Bluetooth™, WiMax, infrared, or other wireless communications link. The wireless connectivity module 328 and the other wireless communications module 332 can each be associated with a shared or a dedicated antenna 324 and a shared or dedicated I/O module 348.

[0105] An input/output module 348 and associated ports may be included to support communications over wired networks or links, for example with other communication devices, server devices, and/or peripheral devices. Examples of an input/output module 348 include an Ethernet port, a Universal Serial Bus (USB) port, Thunderbolt™ or Light Peak interface, Institute of Electrical and Electronics Engineers (IEEE) 1394 port, or other interface.

[0106] An audio input/output interface/device(s) 344 can be included to provide analog audio to an interconnected speaker or other device, and to receive analog audio input from a connected microphone or other device. As an example, the audio input/output interface/device(s) 344 may comprise an associated amplifier and analog-to-digital converter. Alternatively or in addition, the Intelligent TV 100 can include an integrated audio input/output device 356 and/or an audio jack for interconnecting an external speaker or microphone. For example, an integrated speaker and an integrated microphone can be provided, to support near talk or speaker phone operations.

[0107] A port interface 352 may be included. The port interface 352 may include proprietary or universal ports to support the interconnection of the device 100 to other devices or components, such as a dock, which may or may not include additional or different capabilities from those integral to the device 100. In addition to supporting an exchange of communication signals between the device 100 and another device or component, the docking port 136 and/or port interface 352 can support the supply of power to or from the device 100. The port interface 352 also comprises an Intelligent element that comprises a docking module for controlling communications or other interactions between the Intelligent TV 100 and a connected device or component. The docking module may interface with software applications that allow for the remote control of other devices or components (e.g., media centers, media players, and computer systems).

[0108] An Intelligent TV 100 may also include memory 308 for use in connection with the execution of application programming or instructions by the processor 364, and for the temporary or long term storage of program instructions and/or data. As examples, the memory 308 may comprise RAM, DRAM, SDRAM, or other solid state memory. Alternatively or in addition, data storage 314 may be provided. Like the memory 308, the data storage 314 may comprise a solid state memory device or devices. Alternatively or in addition, the data storage 314 may comprise a hard disk drive or other random access memory.

[0109] Hardware buttons 358 can be included for example for use in connection with certain control operations. One or more image capture interfaces/devices 340, such as a camera, can be included for capturing still and/or video images. Alternatively or in addition, an image capture interface/device 340 can include a scanner, code reader, or motion sensor. An image capture interface/device 340 can include or be associated with additional elements, such as a flash or other light source. The image capture interfaces/devices 340 may interface with a user ID module 350 that assists in identifying users of the Intelligent TV 100.

[0110] The Intelligent TV 100 can also include a global positioning system (GPS) receiver 336. In accordance with embodiments of the present invention, the GPS receiver 336 may further comprise a GPS module that is capable of providing absolute location information to other components of the Intelligent TV 100. As will be appreciated, other satellite-positioning system receivers can be used in lieu of or in addition to GPS.

[0111] Power can be supplied to the components of the Intelligent TV 100 from a power source and/or power control module 360. The power control module 360 can, for example, include a battery, an AC-to-DC converter, power control logic, and/or ports for interconnecting the Intelligent TV 100 to an external source of power.

[0112] Communication between components of the Intelligent TV 100 is provided by bus 322. Bus 322 may comprise one or more physical buses for control, addressing, and/or data transmission. Bus 322 may be parallel, serial, a hybrid thereof, or other technology.

[0113] Firmware and Software:

[0114] An embodiment of the software system components and modules 400 is shown in Fig. 4. The software system 400 may comprise one or more layers including, but not limited to, an operating system kernel 404, one or more libraries 408, an application framework 412, and one or more applications 416. The one or more layers 404-416 can communicate with each other to perform functions for the Intelligent TV 100.

[0115] An operating system (OS) kernel 404 contains the primary functions that allow the software to interact with hardware associated with the Intelligent TV 100. Kernel 404 can include a collection of software that manages the computer hardware resources and provides services for other computer programs or software code. The operating system kernel 404 is the main component of the operating system and acts as an intermediary between the applications and data processing done with the hardware components. Part of the operating system kernel 404 can include one or more device drivers 420. A device driver 420 can be any code within the operating system that helps operate or control a device or hardware attached to or associated with the Intelligent TV. The driver 420 can include code for operating video, audio, and/or other multimedia components of the Intelligent TV 100. Examples of drivers include display, camera, flash, binder (IPC), keypad, WiFi, and audio drivers.

[0116] Library 408 can contain code or other components that may be accessed and implemented during the operation of the software system 400. The library 408 may contain one or more of, but is not limited to, an operating system runtime library 424, a TV services hardware abstraction layer (HAL) library 428, and/or a data service library 432. The OS runtime library 424 may contain the code required by the operating system kernel 404 or other operating system functions to be executed during the runtime of the software system 400. The library can include the code that is initiated during the running of the software system 400.

[0117] The TV services hardware abstraction layer library 428 can include code required by TV services either executed in the application framework 412 or an application 416. The TV services HAL library 428 is specific to the Intelligent TV 100 operations that control different functions of the Intelligent TV. The TV service HAL library 428 can also be formed from other types of application languages or embodiments of different types of code or formats for code beyond the hardware abstraction layer.

[0118] The data services library 432 can include the one or more components or codes to implement components for the data services function. The data services function can be implemented in the application framework 412 and/or applications layer 416. An embodiment of a function of the data services and the type of components that may be included is shown in Fig. 6.

[0119] The application framework 412 can include a general abstraction for providing functionality that can be selected by one or more applications 416 to provide specific application functions or software for those applications. Thus, the framework 412 can

include one or more different services, or other applications, that can be accessed by the applications 416 to provide general functions across two or more applications. Such functions include, for example, management of one or more of windows or panels, surfaces, activities, content, and resources, The application framework 412 can include one or more, but is not limited to, TV services 434, TV services framework 440, TV resources 444, and user interface components 448.

[0120] The TV services framework 440 can provide an additional abstraction for different TV services. TV services framework 440 allows for the general access and function of services that are associated with the TV functionality. The TV services 436 are general services provided within the TV services framework 440 that can be accessed by applications in the applications layer 416. The TV resources 444 provide code for accessing TV resources 444 including any types of storage, video, audio, or other functionality provided with the Intelligent TV 100. The TV resources 444, TV services 436, and TV services framework 440 provide for the different implementations of TV functionality that may occur with the Intelligent TV 100.

[0121] One or more user interface components 448 can provide general components for display of the Intelligent TV 100. The user interface components 448 might be general components that may be accessed by different applications provided in the application framework 412. The user interface components 448 may be accessed to provide for panels and silos as described in conjunction with Fig. 5.

[0122] The applications layer 416 can both contain and execute applications associated with the Intelligent TV 100. Applications layer 416 may include one or more of, but is not limited to, a live TV application 452, a video on demand application 456, a media center application 460, an application center application 464, and a user interface application 468. The live TV application 452 can provide live TV over different signal sources. For example, the live TV application 452 can provide TV from input from cable television, over air broadcasts, from satellite services, or other types of live TV services. Live TV application 452 may then present the multimedia presentation or video and audio presentation of the live television signal over the display of the Intelligent TV 100.

[0123] The video on demand application 456 can provide for video from different storage sources. Unlike Live TV application 452, video on demand 456 provides for display of videos that are accessed from some memory source. The sources of the video on demand can be associated with users or with the Intelligent TV or some other type of service. For

example, the video on demand 456 may be provided from an iTunes library stored in a cloud, from a local disc storage that contains stored video programs, or from some other source.

[0124] The media center application 460 can provide applications for different types of media presentation. For example, the media center 460 can provide for displaying pictures or audio that is different from, but still accessible by the user and different from live TV or video on demand. The media center 460 allows for the access of different sources to obtain the media in the display of such media on the Intelligent TV 100.

[0125] The application center 464 allows for the provision, storage and use of applications. An application can be a game, a productivity application, or some other application generally associated with computer systems or other devices, but may be operated within the Intelligent TV. An application center 464 may obtain these applications from different sources, store them locally and then execute those types of applications for the user on the Intelligent TV 100.

[0126] User interface application 468 provides for the specific user interfaces associated with the Intelligent TV 100. These user interfaces can include the silos and panels that are described in Fig. 5. An embodiment of the user interface software 500 is shown in Fig. 5. Here the application framework 412 contains one or more code components which help control the user interface events while one or more applications in the applications layer 416 affects the user interface use for the Intelligent TV 100. The application framework 412 can include a silo transition controller 504 and/or an input event dispatcher 508. There may be more or fewer code components in the application framework 412 than those shown in Fig. 5. The silo transition controller 504 contains the code and language that manages the transitions between one or more silos. A silo can be a vertical user interface feature on the Intelligent TV that contains information for user. The transition controller 504 can manage the changes between two silos when an event occurs in the user interface. The input event dispatcher 508 can receive user interface events that may be received from the operating system and provided to the input event dispatcher 508. These events can include selections of buttons on a remote control or on the TV or other types of user interface inputs. The input event dispatcher 508 may then send these events to a silo manager 532 or panel manager 536 depending on the type of the event. The silo transition controller 504 can interface with the silo manager 532 to affect changes in the silos.

[0127] The applications layer 416 can include a user interface application 468 and/or a silo application 512. The applications layer 416 can include more or fewer user interface applications as necessary to control the user interface of the Intelligent TV 100 than those

shown in Fig. 5. The user interface application 468 can include a silo manager 532, a panel manager 536, and one or more types of panels 516-528. The silo manager 532 manages the display and/or features of silos. The silo manager 532 can receive or send information from the silo transition controller 504 or the input event dispatcher 508 to change the silos displayed and/or to determine types of input received in the silos.

[0128] A panel manager 536 is operable to display panels in the user interface to manage transitions between those panels or to affect user interface inputs received in the panel. The panel manager 536 may thus be in communication with different user interface panels such as a global panel 516, a volume panel 520, a settings panel 524, and/or a notification panel 528. The panel manager 536 can display these types of panels depending on the inputs received from the input event dispatcher 508. The global panel 516 may include information that is associated with the home screen or top level hierarchical information for the user. A volume panel 520 may display information about an audio volume control or other settings for volume. A settings panel 524 can include information displayed about the settings of the audio or video, or other settable characteristics of the Intelligent TV 100. A notification panel 528 can provide information about notifications to a user. These notifications can be associated with information, such as, video on demand displays, favorites, currently provided programs, or other information. Notifications can be associated with the media or with some type of setting, or operation or the Intelligent TV 100. The panel manager 536 may be in communication with the panel controller 552 of the silo application 512.

[0129] The panel controller 552 may operate to control portions of the panels of the types described previously. Thus, the panel controller 552 may be in communication with a top panel application 540, an application panel 544, and/or bottom panel 548. These types of panels may be differently displayed in the user interface of the Intelligent TV 100. The panel control thus may be based on the configuration of the system or the type of display being used currently, put the types of panels 516-528 into a certain display orientation governed by the top panel application 540, application panel 544, or bottom panel application 548.

[0130] An embodiment of the data service 432 and the operation of the data management is shown in Fig. 6. The data management 600 can include one or more code components that are associated with different types of data. For example, there may be code components within the data service 432 that execute and are associated with video on demand, the electronic program guide, or media data. There may be more or fewer types of data service 432 components than those shown in Fig. 6. Each of the different types of data may include a data model 604-612. The data models govern what information is to be stored and how that

information will be stored by the data service. Thus, the data model can govern regardless of where the data comes from, how the data will be received or managed within the Intelligent TV system. Thus, the data model 604, 608, and/or 612, can provide a translation ability or affect the ability to translate data from one form to another to be used by the Intelligent TV 100.

[0131] The different types of data services (video on demand, electronic programming guide, media) each have a data subservice 620, 624, and/or 628 that is in communication with one or more internal and/or external content providers 616. The data subservices 620, 624, and 628 that communicate with the content providers 616 to obtain data that may then be stored in databases 632, 636, and 640. The subservices 620, 624, and 628 may communicate with and initiate or enable one or more source plug-ins 644, 648, and 652 to communicate with the content provider. For each content provider 616, there may be a different source plug-in 644, 648, and 652. Thus, if there is more than one source of content for the data, each of the data subservices 620, 624, and 628 may determine and then enable or initiate a different source plug-in 644, 648, and/or 652. The content providers 616 may also provide information to a resource arbitrator 656 and/or thumbnail cache manager 660. The resource arbitrator 656 may operate to communicate with resources 664 that are external to the data service 432. Thus, the resource arbitrator 656 may communicate with cloud based storage, network based storage, or other types of external storage in the resources 664. This information may then be provided through the content provider module 616 to the data subservices 620, 624, 628. Likewise, a thumbnail cache manager 660 may obtain thumbnail information from one of the data subservices 620, 624, 628 and store that information in the thumbnails database 668. Further, the thumbnail cache manager 660 may extract or retrieve that information from the thumbnails database 668 to provide to one of the data subservices 620, 624, 628.

[0132] An exemplary content aggregation architecture 1300 is shown in Fig. 13. The architecture can include a user interface layer 1304 and a content aggregation layer 1308. The user interface layer 1304 may include a TV application 1312, media player 1316, and application(s) 1320. The TV application 1312 enables the viewer to view channels received via an appropriate transmission medium, such as cable, satellite, and/or the Internet. The media player 1316 views other types of media received via an appropriate transmission medium, such as the Internet. The application(s) 1320 include other TV-related (pre-installed) applications, such as content viewing, content searching, device viewing, and setup algorithms, and coordinates with the media player 1316 to provide information to the viewer.

[0133] The content source layer 1308 includes, as data services, a content source service 1328, a content aggregation service 1332 and a content presentation service 1336. The content source service 1328 can manage content source investigators, including local and/or network file system(s), digital network device manager (which discovers handheld and non-handheld devices (e.g., digital media servers, players, renderers, controllers, printers, uploaders, downloaders, network connectivity functions, and interoperability units) by known techniques, such as a multicast universal plug and play or UPnP discovery techniques, and, for each discovered device, retrieves, parses, and encodes device descriptors, notifies the content source service of the newly discovered device, and provides information, such as an index, on previously discovered devices), Internet Protocol Television or IPTV, digital television or DTV (including high definition and enhanced TV), third party services (such as those referenced above), and applications (such as Android applications).

[0134] Content source investigators can track content sources and are typically configured as binaries. The content source service 1328 starts content source investigators and maintains open and persistent channels for communications. The communications include query or command and response pairs. The content aggregation service 1332 can manage content metadata fetchers, such as for video, audio, and/or picture metadata. The content presentation service 1336 may provide interfaces to the content index 1340, such as an Android application interface and digital device interfaces.

[0135] The content source service 1328 can send and receive communications 1344 to and from the content aggregation service 1332. The communications can include notifications regarding new and removed digital devices and/or content and search queries and results. The content aggregation service 1332 can send and receive communications 1348 to and from the content presentation service 1336 including device and/or content lookup notifications, content-of-interest advisories and notifications, and search queries and results.

[0136] When a search is performed, particularly when the user is searching or browsing content, a user request may be received from the user interface layer 1300, by the content presentation service 1336, which responsively opens a socket and sends the request to the content aggregation service 1332. The content aggregation service 1332 first returns results from the local database 1340. The local database 1340 includes an index or data model and indexed metadata. The content source service 1328 further issues search and browse requests for all content source investigators and other data management systems. The results are forwarded to the content aggregation service 1332, which updates the database 1340 to reflect the further search results and provides the original content aggregation database search results

and the data updates, reflecting the additional content source service search results, over the previously opened socket to the content presentation service 1336. The content presentation service 1336 then provides the results to one or more components in the user interface layer 1300 for presentation to the viewer. When the search session is over (e.g., the search session is terminated by the user or by an action associated with user), the user interface layer 1300 disconnects the socket. As shown, media can be provided directly by the content aggregation service 1332 to the media player 1316 for presentation to the user.

[0137] Remote Control:

[0138] A handheld remote control can be provided to enable user interaction with the Intelligent TV 100. An exemplary handheld remote control is shown in Figs. 7-9. The remote control 700 can include one or more of, but is not limited to, top, side and bottom housings 704, 708, and 712, an (on/off) power button 716, an input source button 720 (to select input source such as Live TV, video on demand, media center, application center, high definition multimedia interface or HDMI, component or COMP, audio/Video or A/V, digital or analog television or DTV/ATV, and video graphics array (VGA)), a (volume) mute button 724, a Live TV button 728 (to activate or select the Live TV silo), a video on demand (VOD) button 732 (to activate or select the video on demand silo), a media center button 736 (to activate or select the media center application or silo, which access various types of media such as music, TV programming, videos, and the like), an application center button 740 (to activate or select the application center application or silo), a global panel button 744, an application panel button 748, a back button 752 (to select a prior user operation or Intelligent TV state and/or navigate up a hierarchy of any displayed image or object(s) (in which case the back button 752 does not navigate within application panels or across application silos), a play button 756 (to play or pause media), a D-pad 760 (which includes north, east, west, and south directional arrows to navigate among displayed images and/or move between levels of an application's or object's hierarchy such as application view navigation, panel navigation, and collection navigation), an OK (or select) button 764 (to select a highlighted displayed image (such as displayed speed control, rewind, forward, play, and pause objects and/or objects on menu bar or in a menu box) and/or navigate down a hierarchy of any displayed image or object(s)), a rocker-type volume-up and volume-down button 768 (to adjust the volume), a menu/guide button 772 (to select for display a menu or guide of programming), a 0-9 (number) button 776 (to display a number pad on the TV screen), a settings button 780 (which launches an application to access current and change TV settings (such as channel settings and settings used to adjust picture and sound effects (e.g., image mode (e.g.,

standard, playground, game, cinema, concert, and studio), brightness, contrast, saturation, color temperature, energy savings, 3D noise reduction, hue, sharpness, zoom mode (e.g., full screen, standard, smart zoom, and dot-to-dot), picture position, 3D mode, for picture, and sound retrieval system or SRS TruSurround, sound mode (e.g., standard, live 1, live 2, theatre, music, speech, user equalizer mode, Left/Right speaker balance, auto volume control, Sony/Philips Interconnect Format or S/PDIF (off, auto, pulse code modulation or PCM) for sound) and system settings (such as system (e.g., selected language for graphical user interface, user geographical and/or geopolitical location information, input method, area settings, and sleep time), network (e.g., WiFi, WiFi hotspot, WiFi direct, Point-to-Point Protocol over Ethernet or PPPoE (asymmetric digital subscriber line or ADSL), Ethernet) settings (e.g., enabled and disabled and selected and non-selected) and information (e.g., network information (e.g., electronic address such as Internet Protocol or IP address, subnet mask, gateway, domain name server information, domain name, Media Access Control or MAC address, service set identification or SSID, security information, and password information) and inline status), manage applications (e.g., currently installed applications, currently executing applications, and internal and external computer readable medium usage), and view user information regarding the Intelligent TV 100)), a rocker-type channel-up and channel-down button 784 (to increment or decrement the selected channel), and first, second, third and fourth hotkeys 788, 792, 794, and 796, and/or a moveable joystick 900 on a bottom of the remote control 700. The first, second, third, and fourth hotkeys are generally assigned different colors, which color indexing is depicted as visual indicia on a selected panel to show the currently assigned function, if any, for each hotkey. As can be seen, the actuator layout can provide a highly efficient, satisfactory, and easily usable experience to the end user.

[0139] Unlike the functional associations and functions of many of the actuators, those of some of the actuators are not readily apparent. A number of examples will now be discussed by way of illustration.

[0140] The media center button 736, when selected, can provide information regarding music, videos, photographs, collections or groupings of music, videos, and/or photographs, and internal and external computational devices (such as personal computers, laptops, tablet computers, wireless phones, removable computer readable media, and the like), which can be grouped in a selected manner (such as favorites, most recently viewed, most watched or viewed, and most recently added). The information can include previews (which can include selected portions of the media content, duration, file size, date created, date last watched, times watched or viewed, and audio and/or video format information).

[0141] The application center button 740, when selected, may provide information regarding pre-installed and downloaded applications. Unlike downloaded applications, pre-installed applications cannot be removed by the user or manually updated. Exemplary pre-installed applications include web browser, settings control, and content search algorithms. By way of illustration, the application center button 740 can provide a scrollable graphical grid of icons (each icon being associated with an application) currently available in the application center.

[0142] The global panel button 744, when selected, can provide the user, via one or more panels or windows, with access to one or more of, but not limited to, silos, notifications, a web browser, system settings, and/or information associated therewith. For example, the global panel button 744 can enable the user to determine what external devices are currently connected to and/or disconnected from the Intelligent TV 100, determine what inputs (e.g., HDMI ports) are currently available for connecting to external devices, determine a connection and/or operational status of a selected external device and/or network (e.g., WiFi connected, Ethernet connected, and offline), assign a custom (or user selected) name to each input source, determine what content is currently being offered on Live TV, on demand, the media center, and/or the application center, access vendor messages and notifications to the user (e.g., system and/or application updates are available), activate the Internet browser, and/or access shortcuts on a displayed shortcut bar to more frequently used and desired applications. Common shortcuts are Internet browser (e.g., Internet search engine), system settings, and notifications. The common types of panels are for information (which is typically information related to a currently displayed image and/or content (e.g., title, date/time, audio/visual indicator, rating, and genre), browse requests, and/or search requests (such as search term field)). Each of the panel types may include a panel navigation bar, detailed information or relevant content to the panel function, operation and/or purpose, and a hotkey bar (defining currently enabled functional associations of hotkeys).

[0143] The application panel button 748, when selected, can display an application window or panel. One application panel may be an information panel regarding a selected (pre-installed or previously downloaded) application icon. The information panel can one or more of identify the selected application, provide a description of the functionality (including application developer and/or vendor, version, release, and/or last update date and a category or type of application based on the application's functionality) and user ratings and/or degree of other user downloading of the application (e.g., a star rating assigned based on one or more of the foregoing inputs), provide the option to launch, remove, update, and add to favorites

the identified application, and provide a listing of selectable links of other (not yet downloaded) recommended applications that provide similar functionality to the identified application. The latter listing can, in turn, provide a description of the functionality (including application developer and/or vendor, version, release, and/or last update date and a category or type of application based on the application's functionality) and user ratings and/or degree of other user downloading of the application (e.g., a star rating assigned based on one or more of the foregoing inputs).

[0144] The functions of the first, second, third, and fourth hotkeys 788, 792, 794, and 796 can change depending on system state, context, and/or, within a selected screen and/or panel, based on a content or currently selected portion of (or relative cursor position on) the screen. Commonly, a currently assigned function of any of the first, second, third, and fourth hotkeys 788, 792, 794, and 796 depends on a currently accessed silo and/or panel (with which the user is currently interacting within the silo). In other words, a first function of one of the first, second, third, and fourth hotkeys 788, 792, 794, and 796 is activated by the respective hotkey in a first system state while a different second function is activated by the respective hotkey in a different second system state. In another example, a third function of one of the first, second, third, and fourth hotkeys 788, 792, 794, and 796 is activated by the respective hotkey when a user focus (or currently selected cursor position or screen portion) is at a first screen position while a different fourth function is activated by the respective hotkey when a user focus (or currently selected cursor position or screen portion) is at a different second screen position. The first screen position can, for instance, be within an icon while the second screen position is outside of the icon. Hotkey functionality that could be enabled when in the first screen position may be “configure” and “remove” and disabled is “add”, and, when in the second position hotkey functionality enabled can be “add” and disabled is “configure” and “remove.” Generally, the states of hotkeys can include normal (for enabled actions or functions), disabled (when an action or function is temporarily disabled), pressed (when selected by a user to command an action or function to be performed), and unavailable (when no association between the hotkey and an action or function is currently available). While examples of hotkey functions are discussed below, it is to be understood that these are not intended to be exhaustive or limiting examples.

[0145] The first hotkey 788, when selected in a first system state, can enable the user to assign, change, or edit a name of an input source. It is typically enabled only when the input source of HDMI, Comp/YPbPr (e.g., component video cables), video output, and VGA is in

focus. When selected in a second system state, the first hotkey 788 can return the user to a top of a scrollable collection of objects, such as application icons.

[0146] The second hotkey 792 may show all or less. In other words, the hotkey 792 can allow the user to show all inputs, including the unconnected/undetected ones and to hide the unconnected/undetected inputs, e.g., to expand and collapse the silo/input list. Each input source can have one of two states, namely connected/detected and unconnected/undetected. Some input sources, including Live TV, video on demand, media center, and application center are always connected/detected.

[0147] The moveable joystick 900 on the bottom of the remote control 700, when manipulated, can cause a displayed image on the Intelligent TV 100 screen to be displaced a proportional amount. In other words, the displayed image is displaced substantially simultaneously with displacement of the joystick 900 within the joystick aperture 904 in the bottom housing 712 of the remote control. As shown in Figs. 9B-C, the joystick 900 moves or slides between forward and reverse positions. Releasing the joystick 900 causes the joystick 900 to return to the center position of Fig. 9A, and the window to move or slide upwardly (when the joystick is released from the joystick position of Fig. 9B) or downwardly (when the joystick is released from the joystick position of Fig. 9C) until it disappears from view as shown in Fig. 11A. The effect on the screen of the Intelligent TV 100 is shown in Figs. 11A-C. In Fig. 11A, video content, such as TV programming, a video, movie, and the like, is being displayed by front surface of the screen 212. In Fig. 11B, the joystick 900 is moved or slid to the upper position of Fig. 9B, and a drop down window or panel 1100 moves or slides down (at the substantially the same rate of joystick 900 movement) at the top of the screen 212. In Fig. 11C, the joystick 900 is moved or slid to the lower position of Fig. 9C, and a drop up window or panel 1100 moves or slides up (at the substantially the same rate of joystick 900 movement) at the bottom of the screen 212. The window 1100 partially covers the video content appearing on the remainder of the screen 212 and/or causes a portion of the screen 212 displaying video content to move and/or compress up or down the height of the window 1100.

[0148] The window 1100 can include one or more of information (which is typically information related to a currently displayed image and/or content (e.g., panel navigation bar, detailed information (e.g., title, date/time, audio/visual indicator, rating, and genre), and hotkey bar (defining current functional associations of hotkeys)), browse requests, and/or search requests. Commonly, the window 1100 includes suitable information about the content (such as name, duration, and/or remaining viewing duration of content), settings

information, TV or system control information, application (activation) icons (such as for pre-installed and/or downloaded applications such as application center, media center and Web browser), and/or information about input source(s). When the joystick 900 is in either the forward or reverse position, the user can select an actuator on the front of the remote control, such as the OK button 764, and be taken, by displayed images on the screen 212, to another location in the user interface, such as a desktop. This process can be done in a nonintrusive manner and without affecting the flow of content that is pushed up or down. The joystick 900 could be moved, additionally or differently, from side-to-side to cause the window to appear at the left or right edge of the screen 212.

[0149] An alternative actuator configuration is shown in Fig. 10. The actuators are substantially the same as those of Figs. 7-9 except that the social network button 1000, when selected, can automatically select content and publish, via a social network service or other social media, the content to a social network or online community. User or viewer comments and/or other messages can be included in the outbound message. For example, all or one or frames or portions of media content (such as a video, music, a photograph, a picture, or text) can be provided automatically to a predetermined or selected group of people via LinkedIn™, MySpace™, Twitter™, YouTube™, DailyMotion™, Facebook™, Google+™, or Second Life™. The user, upon activating the button 1000 could, in response, select a social forum or media upon which the selected content (which is the content displayed to the user when the social network button 1000 is activated) is to be posted and/or a predetermined group within that social media to which the content is to be posted. Alternatively, these selections could be preconfigured or preselected by the user.

[0150] The social network button can also be used to “turn up” or “turn down” a social volume visualization. The Intelligent TV 100 can create dynamically a visualization of aggregated connections (and inbound and/or outbound messages) from a variety of social networks. The aggregation (and inbound and outbound messages) can be depicted graphically on the screen as a volume of connections to influence the viewer user. With a social volume visualization, selected contents of each linked social network profile of a social contact (and inbound and/or outbound messages from or to the linked social network contact and/or current activity of the social contact (such as watching the same programming or content the viewer is currently watching) can be presented in a separate tile (or visually displayed object). The size of the tile can be related to any number of criteria, including a relationship of the linked social contact (e.g., a relative degree of importance or type of relationship can determine the relative size of the tile, a degree of influence of the linked

social contact to the current viewer, a geographic proximity of the linked social contact to the current viewer, a degree to which the currently provided media content is of interest to both the viewer and linked social contact (e.g., both parties enjoy war movies, murder mysteries, musicals, comedies, and the like), an assigned ranking of the linked viewer by the viewer, a type of social network type linking the viewer with the linked social contact, a current activity of the social network contact (e.g., currently watching the same content that the viewer is currently watching), a current online or offline status of the linked social contact, and a social network grouping type or category to which both the viewer and linked social contact belong (e.g., work contact, best friend, family member, etc.).

[0151] The viewer can designate a portion of the screen to depict the social network aggregation. By turning the social volume up (+) or down (-), the viewer can increase the size and/or numbers of linked contact tiles provided to the viewer. In other words, by increasing the social volume the viewer can view, access, and/or push more social content from those of his or her social networks associated with him or her in a memory of the Intelligent TV. By decreasing the social volume, the viewer can view, access, and/or push less social content from his or her associated social networks. By selecting the mute button 724, the viewer can stop or pause any interactivity with his or her associated social networks (e.g., inbound or outbound messages). Social volume and/or mute can be separated into two (or more) volume settings for outbound and inbound social network activity. By way of illustration, a first volume setting, control, and/or button can control the volume for outbound social network activity (e.g., outbound social messages) while a second (different) volume setting, control, and/or button can control the volume for inbound social network activity (e.g., inbound social messages). By way of further illustration, a first mute setting, control, and/or button can stop or pause outbound social network activity (e.g., outbound social messages) while a second (different) mute setting, control, and/or button can stop or pause inbound social network activity (e.g., inbound social messages).

[0152] A functional block diagram of the remote control is shown in Fig. 12. The remote control 700 includes a controller 1208 to control and supervise remote control operations, optional wireless (RF) transceiver 1224 and antenna 1244 to send and receive wireless signals to and from the Intelligent TV 100 and other external components, optional infrared emitter 1228 to emit infrared signals to the Intelligent TV 100, optional light emitting diode or LED driver 1232 to control LED operation to provide video-enabled feedback to the user, actuators 1220 (including the various buttons and other actuators discussed above in connection with Figs. 7 and 10), and joystick 900, all interconnected via a bus 1248. An on

board power source 1200 and power management module 1204 provide power to each of these components via power circuitry 1240. The infrared emitter 1228 and receiver (not shown) on the Intelligent TV system 100 can be used to determine a displayed object illuminated by the infrared signal and therefore adjust the displayed image, for example to indicate a focus of the user (e.g., illuminate a displayed object or show cursor position relative to displayed objects on the screen) and to determine and activate a desired command of the user. This can be done by tracking a position of the remote control in relation to infrared tracking reference points (e.g., a sensor bar or infrared LED's) positioned on or adjacent to the screen of the Intelligent TV 100. Motion tracking can further be augmented using position information received from a multi-axis gyroscope and/or accelerometer on board the remote control (not shown).

[0103] Fig. 14 shows a data service 432 and the operation of the data management 1400 according to an embodiment. Similar to data management 600 shown with respect to Fig. 6, data management 1400 is supported by data service 432 according to another embodiment.

[0104] The data management 1400 includes one or more code components that are associated with different types of data. For example, code components may include codes associated with video on demand (VOD), electronic program guide (EPG), media data, and/or other codes. Code components are executable and a part of data service 432. Data management may associate and access the code components as needed.

[0105] Each of the different types of data may include a data model (*i.e.*, VOD data model 1404, EPG data model 1408, and media data model 1412). The data models define what and how information is to be stored by the data service. Thus, the data model can be defined to accommodate a variety of data sources without discriminating as to where the data comes from and how the data will be received or managed within the Intelligent TV system. Thus, the data models provide translation ability and/or affect the ability to translate data from one form to another to be used by the Intelligent TV 100.

[0106] The different types of data services (video on demand, electronic programming guide, media) each have a data subservice component (*i.e.*, VOD subservice 1420, EPG subservice 1424, and media subservice 1428) that is in communication with one or more internal and/or external sources. Each data subservice component is in communication with the corresponding source plugins (*i.e.*, VOD source plugins 1444a-n for VOD subservice 1420, EPG source plugins 1448a-n for EPG source subservice 1424, and media source plugins 1452a-n for media source subservice 1428).

[0107] In one implementation, the corresponding source plugins 1444a-n, 1448a-n, and 1452a-n can operate within the data management 1400 to interface, communicate, and/or query with external sources to gather data from these external sources. Plugins that communicate with external sources may be internally configured and provided by Intelligent TV 100. Plugins may also be provided and configured by third-parties such as an official plugin for the service provided by the external source or another third party which has developed a suitable plugin for Intelligent TV 100 to communicate with the external source using an API or other liked platform for the external source. Plugins are developed to interface with the corresponding subservice in Intelligent TV 100 for data management 1400.

[0108] For example, each of VOD source plugins 1444a-n may be configured to communicate with one specific VOD source or some plurality of VOD sources. Some VOD sources include dedicated media sources (*i.e.*, over the internet), such as Amazon Instant Video, AOL Video, Blockbuster, DailyMotion, Google Play, Hulu, Joost, IPTV, iTunes Store, MetaCafe, NetFlix, Pandora, PlayStation Store, Vimeo, Voddler, Vudu, WatchESPN, YouTube, Xbox Video, or other dedicated distribution platforms and other content websites. Other VOD sources may include over-the-air or cable VOD sources with analog or digital feeds. Intelligent TV 100 may also access internal data storage (*i.e.*, data storage 314) or other external storage (*i.e.*, digital media library 148) that contains additional VOD media. Further, devices connected to Intelligent TV 100 (*i.e.*, devices 168 or other devices accessible to Intelligent TV 100 over network 132) may also contain additional VOD media. Each of these media sources may have a corresponding VOD source plugin developed that can communicate with the specific media source. Further, third parties may develop a VOD source plugin that works with a number of media sources. Communication between the VOD source plugin may include from simply requesting and displaying a requested media or may include accessing the media library of the media source (*i.e.*, listing new updates or additions, recommended media, listing media by genres, and/or other functions) and other functions.

[0109] In another example, EPG source plugins 1448a-n include plugins that are configured to communicate with various external sources. Exemplary EPG sources include analog or digital feeds from the content provider, the internet, and/or other sources.

[0110] Content providers (*i.e.*, over-the-air, cable, and/or satellite channels) may have EPG information embedded with the content feed delivered to the user (*i.e.*, as a subchannel of the main content feed). EPG information that is embedded with the content feeds by the content providers may contain only limited information due to technical (*i.e.*, limited bandwidth) and

content (*i.e.*, rights to third-party generated EPG contents) limitations with embedding EPG information with content feeds.

[0111] The Internet is also a source of EPG information. A variety of EPG information is distributed over the Internet for equipment or computers that are directly connected to the Internet. EPG information over the Internet usually includes more detailed information regarding TV programming than with embedded EPG information in content feeds (*i.e.*, detailed description of programming, reviews of programming, schedule, and future programmings). Further, EPG information over the Internet may also contain non-text contents such as preview images, videos, and sounds.

[0112] Other sources may also provide EPG information. In some instances, a collection of feeds (*i.e.*, cable or satellite TV) may contain a specific channel dedicated to displaying EPG information. These EPG channels may contain video display of an analog or digital signal containing the EPG information (*i.e.*, programming schedule in chart form). Other instances may include a feed containing EPG information in list form (*i.e.*, for set-top boxes or digital video recorders (DVRs)).

[0113] An exemplary EPG source plugin receives and processes EPG information from a designated EPG information source. The EPG source plugin is configured to process the received EPG information according to the specific format of the corresponding designated EPG information source. For example, EPG information embedded with content feeds may contain limited information that are ordered in a pre-defined format (*i.e.*, the order of other relevant information such as title, time, description, and/or other information about the programming). EPG information taken from an internet source may contain more detailed information but may require parsing to organize the relevant information within data management 1400. The EPG source plugin may further organize or translate the information received into a common data format to be stored in database 1436. In one implementation, EPG source plugins 1448a-n may convert or translate the received EPG information into a consistent data model for data management 1400 (*i.e.*, EPG data model 1408) for consistency within data management 1400 and other reasons.

[0114] Media source plugins 1452a-n are configured to interface or communicate with the various media sources available to Intelligent TV 100. For example, media sources may include media content in connected devices 168 or other devices or media contents that are accessible to Intelligent TV 100 (*i.e.*, via network 132). Each media source may contain content in a specific format (*i.e.*, DVD, BluRay, and other digital or analog formats). Further, media from live feeds (*i.e.*, from over-the-air broadcast, cable or satellite feeds, Internet

feeds) are contents in a live format specific to the type of feed. Further, media contents and feeds from the various sources may also include metadata information embedded with these contents (*i.e.*, closed captions, subtitles, and other information). In one implementation, media source plugins 1452a-n are configured to receive media contents and information for one or more of these media sources in a specific format.

[0115] Similar to as discussed with respect to the EPG source plugins 1448a-n, VOD source plugins 1444a-n and media source plugins 1452a-n may need to translate the various different media format and information received into a consistent model. In one implementation, information related to the VOD or media received from a corresponding VOD source plugin or media source plugin can be translated according to the respective VOD data model 1404 or media data model 1412 and stored into the respective storage 1432 or storage 1440. The VOD or media content received can be stored directly in the respective storage 1432 or storage 1440 or may be sent to the respective subservice without being stored. The format of the VOD or media can be decoded and played by Intelligent TV 100 directly using the information regarding format received. In another implementation, the VOD or media content received may be converted into a consistent format for all contents. This may be helpful for various display configurations (*i.e.*, displaying as thumbnails, previews, etc.) depending on the hardware configurations and capabilities of Intelligent TV 100.

[0116] In a further embodiment, each source plugin may communicate with a plurality of different service providers and may not be grouped by criteria such as geographic area. For example, an EPG source plugin may be configured to work with EPG sources in a country (*i.e.*, Canada providing fees in English and French) or a localized region (*i.e.*, southwestern U.S. providing fees in English and Spanish) or feeds limited to only local stations in an area.

[0117] The data model, subservice, and source plugins for VOD, EPG, and media contents are discussed above according to an embodiment. In alternate embodiments, additional features may be included consistent with the framework discussed as known or may be derived by one skilled in the art.

[0118] Data management 1400 further includes a plurality of content provider modules 1416. Content provider modules 1416 works with the various data subservices (*i.e.*, VOD subservice 1420, EPG subservice 1424, and media subservice 1428) to provide customized media data and information for applications 416 in Intelligent TV 100. Specifically, content provider modules may serve applications 416 in Intelligent TV 100 with customized data and information related to live TV 452, VOD 456, media 460, application center 464, user

interface 468, and/or other applications. Further, content provider modules 1416 may perform additional functions to organize or provide data in support of other content provider modules. Exemplary content provider modules include EPG data provider 1416a, media data provider 1416b, media browser 1416c, media scanner 1416d, and thumbnail engine 1416e.

[0119] In one example, EPG data provider 1416a is configured to serve applications with EPG information in a read-only format. In one implementation, EPG data provider 1416a works with EPG subservice 1424 to serve EPG information collected and stored in storage 1436. A relevant application in applications 416 may request EPG data provider 1416a to provide relevant EPG information as needed by the relevant application. For example, live TV 452 may display relevant EPG as a header when displaying a programming. Media center 460 may display relevant EPG information for selected programming when displayed or selected by the user via user interface 468.

[0120] In another example, media data provider 1416b is configured to provide personalized media metadata and stores the personalized media metadata into a database for further access. In one implementation, the personalized media metadata is stored in a sqlite database. The user may set up a personalized profile or preference for types, genres, or other preferred characteristics of media. The user may access and set up the profiles in a corresponding application. Alternatively, Intelligent TV 100 may contain pre-defined profiles and/or may automatically build a profile for a user by analyzing the user's past viewing preferences progressively. Media data provider 1416b may work with media subservice 1428, VOD subservice 1420, and/or other subservices. For example, media data provider 1416b uses the metadata regarding media collected by media subservice 1428 in order to generate the personalized media metadata.

[0121] Media browser 1416c is configured to provide a view of the media sources in real-time. Further media browser 1416c maintains a list of the connected media sources. In one implementation, media browser 1416c does not require any permanent storage as media browser 1416c is configured to collect real-time information. Media browser 1416c may work with VOD subservice 1420, media subservice 1428, and/or other subservices to gather information pertaining to a list of media sources and/or contents available. For example, media subservice 1428 may receive information pertaining to connected devices 168 and whether the connected devices 168 have accessible media contents via the respective media source plugins 1452a-n. Media browser 1416c may maintain a list of the connected devices 168 in real-time and may be accessible by the user directly or from other applications. In one implementation, media browser 1416c may run in the background or may be periodically run

to update the list in real-time. This allows Intelligent TV 100 to have a list of connected media sources available without additional wait time to poll device information when the information is needed.

[0122] Media scanner 1416d is configured to provide a table of media using data retrieved from media browser 1416c. In one implementation, media scanner 1416d rescans the information periodically and updates the table of media. Media scanner 1416d may provide the table of media for applications such as media center 460 to display to the user the accessible media. In another implementation, media scanner 1416d may also work with EPG subservice 1424 to further populate the media table with updated EPG information.

[0123] Thumbnail engine 1416e is configured to collect and provide thumbnails for media, applications, and other contents. For example, thumbnail engine 1416e may collect or capture (*i.e.*, screen capture a scene from available media) from a variety of subservices providing content or media (*i.e.*, VOD subservice 1420, media subservice 1428). Thumbnail engine may also collect available thumbnails from EPG information via EGP subservice 1424. In one implementation, thumbnail engine 1416e may also collect and provide short video previews or scenes of media.

[0124] In an embodiment, thumbnail engine 1416e may also communicate with thumbnail cache manager 1460 and thumbnail storage 1468. Thumbnails for various programming may be needed for a number of applications for displaying programming information. Thumbnail cache manager 1460 may separately provide pre-cached thumbnails for the efficiency of displaying graphical thumbnails which consist of larger data blocks than text data such as EPG information. Thumbnail engine 1416e may also facilitate creating and maintaining the thumbnail cache for applications.

[0125] Resource arbitration 1456 may operate and facilitate communication between the subservices, source plugins, and various resources of Intelligent TV 100 that are external to data service 432. Thus, the resource arbitrator 1456 may communicate with cloud and/or network based storages 1461 or other types of external storage in the resources. In one implementation, the information from the storages 1461 may be accessible through the content provider modules 1416 to the sources plugins or the subservices as applications are accessible by Intelligent TV 100. In another implementation, the source plugins and the subservices may directly access storage resources through resource arbitrator 1456 depending on the hardware and for data efficiency reasons.

[0153] Resource arbitrator 1456 may further access other resources of the Intelligent TV 100, such as video hardware 1462, display 1463, and other resources. For example, resource

arbitrator 1456 may directly access video hardware 1462 and display 1463 to decode and display programming having a variety of encodings (*i.e.*, DVD, BluRay, various VOD native formats).

[0154] Fig. 15 shows an EPG data service 1500 for an Intelligent TV 100 according to an embodiment.

[0155] EPG data service 1500 includes EPG subservice 1510, EPG provider 1520, digital TV (DTV) signal source plugin 1531, DTV cloud source plugin 1532, analog TV (ATV) signal source plugin 1533, databases 1511 and 1512, DTV manager 1541, ATV manager 1543, thumbnail cache manager 1550, and tag subservice 1560. In one implementation as discussed with respect to Fig. 14, EPG data service 1500 includes components corresponding to components in data service 1400. For example, EPG provider 1520 corresponds to EPG data provider 1416a, EPG subservice 1510 corresponds to EPG subservice 1424, source plugins 1531, 1532, and 1533 correspond to EPG source plugin 1444a-n, and database 1511 corresponds to EPG database 1436. Further, thumbnail cache manager 1550 corresponds to thumbnail cache manager 1460.

[0156] The operation of EPG data service 1500 is described according to an embodiment.

[0157] Generally, EPG data service 1500 serves applications 1571 (*e.g.*, applications 416) with EPG information in a read-only manner. The applications 1571 are specifically served by EPG provider 1520, which in turn is served by EPG subservice 1510.

[0158] As discussed, applications 1571 interface with the data services using a pre-defined interface. In one implementation, applications 1571 query for EPG data from EPG provider 1520 using the standard Android ContentProvider interface. As such, EPG provider 1520 interfaces and filters application queries and forwards requests from applications 1571 to EPG subservice 1510 for handling. The EPG provider 1520 may be implemented as a light ContentProvider wrapper.

[0159] For example, EPG data service may store and provide EPG information the programs with standard data fields, such as id, name description, start date/time, and duration. Applications 1571 may access EPG for programs in either analog or digital channels as well as channel lists using dedicated parameters in a Content Provider query that specifies a type of filtering. Further, applications 1571 may also request to set and/or clear reminders and favorites for EPG information using the standard Content Provider interface. As discussed, EPG provider 1520 forwards the request from applications 1571 for EPG subservice 1510 to handle. Requested data is returned to applications 1571 using standard “cursor” structures.

[0160] Further, in one implementation, EPG provider 1520 may also implement Content Observers on data that it provides. For example, some observing applications 1571 (*i.e.* Live TV 452) may require constant update to content such as EPG information. EPG provider 1520 may provide notifications to these observing applications when EPG data gets updated without requested by the applications.

[0161] Generally, the EPG subservice 1510 asynchronously maintains the EPG information in a database 1511. Database 1511 may also represent generally the Content Provider's local storage. In one configuration, database 1511 is SQLite-based and maintains a storage of approximately 3 days to one week of EPG information.

[0162] The EPG subservice 1510 is bound to and receives input from a series of EPG source plugins, which access and fetch the EPG data from available sources of the respective EPG source plugins. The information returned by each EPG source plugin is provided in a common, pre-defined data structure. It is noted here that the various EPG source plugins may actually fill the common data structure with more or less information than other EPG source plugins, as the availability of the EPG information is dependent of the actual EPG source itself. For example, media assets, such as channel logos or TV series posters, are not available to EPG information that is contained in a content feed stream (*i.e.*, analog or digital broadcast streams) but may be available from an Internet source. As such, the EPG subservice 1510 may collect disparate, incomplete EPG information from the available source and may assemble and construct a more complete EPG information for a specific program from the various sources based on a set of internal rules.

[0163] In one implementation, some source plugins may notify the EPG subservice 1510 when EPG data needs to be refreshed; for example, the source plugin may have detected that the EPG data has been updated from the source or a channel list has been updated from a TV channel scan for a content feed stream. As such, EPG subservice 1510 may notify the interested parties (*i.e.* modules or applications) that an EPG update operation is about to start or has been finished. For example, as discussed previously, the EPG subservice 1510 may inform the EPG provider 1520 to notify an observing application when EPG information has been updated.

[0164] EPG data service 1500 may further include thumbnail cache manager 1550.

[0165] Thumbnail cache manager 1550 may serve thumbnails of programs directly to applications 1571. In one implementation, applications 1571 receive media data that is associated with the EPG data set responses from EPG provider 1520 in the form of Thumbnail Cache Manager Uniform Resource Identifiers (URIs), which represent locators

for a given thumbnail resource. Applications 1571 may then directly fetch the actual media assets (*i.e.*, channel logos, TV series posters, and other media thumbnails for a program) directly from thumbnail cache manager 1550 using the Thumbnail Cache Manager URIs. Thumbnail cache manager 1550 will then serve the actual media asset directed by the Thumbnail Cache Manager URIs to applications 1571.

[0166] As such, thumbnail cache manager 1550 may maintain storage of media assets in a separate storage (*i.e.*, storage 1468) or in a local EPG database 1511 along with other EPG information. The choice of storage may affect the performance of serving the thumbnails such as efficiency of serving various media assets versus EPG information because media assets tend to involve more storage space than EPG information.

[0167] In one implementation, EPG subservice 1510 may also handle maintaining the thumbnail cache with the media assets in the storage as the various sources of EPG data may also be the sources for thumbnails (*i.e.*, an Internet source with EPG and thumbnail resources). Since EPG subservice 1510 handles the various EPG data from the various sources, the EPG subservice 1510 may further keep track of and store the thumbnails; the thumbnail storage location is saved as a Thumbnail Cache Manager URI; and the actual thumbnail is served by thumbnail cache manager from the storage as discussed above. Similar to the EPG information, EPG subservice 1510 may also use a set of internal rules to update and maintain conflicting or incomplete thumbnail cache contents. In another implementation, thumbnail cache manager 1550 may directly access a thumbnail source (*i.e.*, Internet 1592) to retrieve the thumbnail resources.

[0168] EPG data service 1500 may further include tag subservice 1560.

[0169] Tag subservice 1560 uses database 1512 to store and persist data as tags. In one configuration, tag types are defined, such as “reminders,” and “favorites.” Tag subservice 1560 uses alarm manager 1581 to generate alarms and/or notifications for an event related to a tag.

[0170] For example, tag subservice 1560 may receive request from reminder panel 1572 from system UI to set or unset a reminder for a program. Tag subservice 1560 sets the reminder in database 1512. Alarm manager 1581 will notify tag subservice 1560 at the time of the scheduled reminder, and tag subservice 1560 will notify the reminder panel or other UI application when a reminder is due.

[0171] In one implementation, the EPG subservice 1510 can merge the EPG data stored in database 1511 along with the reminders and favorites as queried from tag subservice 1560 to create data set responses returned to requests coming from EPG provider 1520 from

applications 1571. For example, an application 1571 may request EPG for information tagged as reminders or favorites. The EPG subservice 1510, in response to the request, may query tag subservice 1560 for programs tagged as reminders or favorites and merge the EPG information for these programs in database 1511 and further respond to the request by the application 1571. In one configuration, databases 1511 and 1512 may be merged depending on the configuration of EPG data service 1500.

[0172] EPG data service 1500 further includes DTV signal source plugin 1531, DTV cloud source plugin 1532, and ATV signal source plugin 1533.

[0173] As discussed previously, the EPG information is aggregated from multiple sources by EPG subservice 1510. Exemplary sources may include DTV signal source plugin 1531 for digital broadcast streams, ATV signal source plugin 1533 for analog broadcast streams, and DTV cloud source plugin 1532 for Internet sources. In particular, DTV signal source plugin 1531 supports Digital Video Broadcast Cable (DVB-C) streams, and DTV cloud source plugin 1532 supports HiCloud.

[0174] The source plugins use a common interface that the EPG subservice 1510 uses to communicate between the source plugins and EPG subservice 1510. The source plugins will fetch EPG data from the respective source that they are accessing and return the EPG data to EPG subservice 1510 to aggregate and merge the EPG data into a common data structure as discussed above. In one implementation, the source plugin may use an EPG Data Aggregator to aggregate the EPG data into the common data structure before merging the data from the various source plugins by EPG subservice 1510.

[0175] In one implementation, the source plugins are also able to inform the EPG subservice 1510 about EPG-related events from the respective sources, such as when new updates are available from the sources.

[0176] DTV signal source plugin 1531 receives EPG information from a plurality of digital signal sources. DTV signal source plugin 1531 may work with DTV manager 1541 (which may be common to other modules outside of EPG data service 1500 for Intelligent TV 100) that receives DTV signals for Intelligent TV 100 including the media and EPG feeds. DTV signal source plugin 1531 fetches and filters the DTV signal for EPG information to send to EPG subservice 1510. As such, DTV signal source plugin 1531 may be designed as a DTV Manager client as discussed with the TV API. In particular, DTV signal source plugin 1531 works with DVB-C stream to fetch the EPG information provided by the DVB-C stream and polls for updates to the EPG information.

[0177] DTV cloud source plugin 1532 receives EPG information from a plurality of EPG sources over the Internet. Similar to DTV signal source plugin 1531, DTV cloud source plugin 1532 fetches EPG information from various Internet and cloud sources. In particular, DTV cloud source plugin 1532 works with HiCloud to fetch the EPG information provided by HiCloud. DTV cloud source plugin 1532 may implement the HiCloud SDK, other SDK or other access means to work with fetching the EPG information from HiCloud or other Internet or cloud sources. DTV cloud source plugin 1532 may use the HiCloud Account Management facilities to perform the sign on operation for HiCloud.

[0178] ATV signal source plugin 1533 receives EPG information from a plurality of analog signal sources similar to DTV signal source plugin 1531 for digital sources. In one implementation, ATV signal source plugin 1533 may fetch only analog channel list as the analog signal feeds may contain no other EPG information. Similar to DTV signal source plugin 1531, ATV signal source plugin 1533 may work with ATV manager 1543 and may be designed as an ATV Manager client as discussed with the TV API.

[0179] Fig. 16 shows a flow diagram of an EPG management process according to an embodiment.

[0180] Process 1600 starts with polling EPG source for updated EPG information 1610.

[0181] EPG data service 1500 may poll a number of EPG sources (*i.e.*, digital and analog signal feeds 1591 and 1593 and the Internet and/or cloud 1592) for updated EPG information through DTV signal source plugin 1531, DTV cloud source plugin 1532, and ATV signal source plugin 1533. In particular, two digital sources include DVB-C and HiCloud.

[0182] Analog channels from analog signal feeds may have little to no EPG information associated. Therefore, dummy EPG data may be associated with a plain channel list (*i.e.*, dummy EPG time slots such as 4-hour, one day long, to-be-determined (TBD)) and a standard label indicating “no program information available.” For digital channel events that have little or no EPG information, the same indicator as described above may be used.

[0183] A EPG polling interval may be set to time each poll of EPG information from the various sources. In particular, users may specify a value via Settings that indicates when the source plugins may poll EPG data from the respective sources. For example, the EPG polling interval may be set as every 24 hours. Further, a starting time may be set (e.g., in the middle of the night, 3am) in such a way that it will cause a minimum impact on the TV experience as EPG information polling may require more than usual amount of bandwidth. In one implementation, a default value may be set for the polling schedule (*i.e.* every 24 hours) and the starting time (*i.e.* 3am) in which a user may or may not override the default setting

depending on manufacturer's specifications, EPG source rules, local regulations, and other factors.

[0184] In one implementation, EPG information polling may further be triggered by channel scanning operations. For example, the user or the system may generate a channel scanning operation (*i.e.*, when Intelligent TV 100 is scanning for new channels). If the channel list has changed as a result of the scan (*i.e.*, a new channel has been registered as a result of the scan), the EPG respective source plugins can take appropriate action (*i.e.*, polling for EPG information for a new channel) upon analyzing the scan result. In one configuration, the EPG source plugins can handle the event by listening to scan events produced by DTV manager 1541 or ATV manager 1543.

[0185] The HiCloud service or generally EPG information from Internet or cloud sources may not be organized or have any notion of location and/or region. In one implementation, EPG data service 1500 may pull EPG information from DTV cloud sources by using the channel name list as available to DTV manager 1541 (*i.e.* upon digital channel scanning) and providing the channel list to the relevant service. For example, HiCloud service may receive the channel name list request from DTV cloud source plugin 1532 and analyze the list to provide appropriate EPG data matching the channel names on the list.

[0186] In one implementation, the DTV cloud source plugin 1532 may retrieve the entire EPG from a source every time a download is initiated. As such, EPG data service 1500 may analyze and filter the appropriate EPG data matching the channel names on the channel name list. EPG data service 1500 may further analyze and filter only EPG data that are relevant over a specific time interval for the user. In another implementation, DTV cloud source plugin 1532 may send a specific time interval (*i.e.*, date and time) to a source to see if an update for EPG information is available.

[0187] In some implementations, EPG data service 1500 may further pull full EPG information for selected programs and/or channels 1615.

[0188] For example, pulling the full EPG for all digital channels from the DVB-C stream by DTV signal source plugin 1531 may require the Intelligent TV 100 to be tuned to one or more "pilot" channels. This may impact user experience such as with irrelevant or unwanted EPG information and/or high bandwidth usage. As such, EPG data service 1500 may choose to pull full EPG information for only selected programs and/or channels. The relevant programs and/or channels may be selected by the user or automatically by EPG data service 1500 according to certain rules such as feed type and geography and matching the channels with "pilot" channel databases.

[0189] Next, EPG data service 1500 aggregates the received EPG information from a number of sources 1620.

[0190] As discussed above, EPG subservice 1510 filters and aggregate the various incomplete EPG information received from the plurality of EPG information sources according to certain rules. For example, a rule may consider that Internet EPG data tends to be more reliable than DVB-C EPG data. Therefore, the EPG subservice 1510 may define a rule for aggregating the EPG information coming from various sources may consider the DVB-C stream based EPG as being the primary one. Once the DVB-C EPG data is collected for all digital channels, the HiCloud Internet EPG may be fetch, if available. If there are any conflicts in a field of EPG information between the DVB-C EPG information and the HiCloud Internet EPG information, the conflict that may be encountered across these sets of data may be resolved by having the Internet EPG data overwriting the DVB-C stream EPG data. As such, there is a hierarchical EPG data selection list and also a primary EPG information source.

[0191] Next, EPG data service 1500 provides the relevant EPG information to an application 1630.

[0192] As discussed above, EPG provider 1520 will format EPG information from EPG subservice 1510 and serve to applications 1571 according to a request from applications 1571. EPG provider 1520 will also forward updated information based on reminders, favorites, or other tags for programs and/or channels set by tag subservice 1560. EPG provider 1520 may also forward updated EPG information as sent by the source plugins as discussed above.

[0193] In one implementation, the EPG information returns to applications 1571 may include a “channel GUID” that uniquely identifies the channel regardless if it is an analog or digital channel. The channel GUID may be in the form of a URI similar to a media resource for thumbnail cache manager 1550 as discussed above. The channel GUID may be passed to an API that changes the channel GUID to the channel. This may be available to access the channel resources directly (*i.e.*, EPG information stored in database 1511 and/or other channel resources).

[0194] The exemplary systems and methods of this disclosure have been described in relation to EPG function for an Intelligent TV. However, to avoid unnecessarily obscuring the present disclosure, the preceding description omits a number of known structures and devices. This omission is not to be construed as a limitation of the scopes of the claims. Specific details are set forth to provide an understanding of the present disclosure. It should

however be appreciated that the present disclosure may be practiced in a variety of ways beyond the specific detail set forth herein.

[0195] Furthermore, while the exemplary aspects, embodiments, and/or configurations illustrated herein show the various components of the system collocated, certain components of the system can be located remotely, at distant portions of a distributed network, such as a LAN and/or the Internet, or within a dedicated system. Thus, it should be appreciated, that the components of the system can be combined into one or more devices, or collocated on a particular node of a distributed network, such as an analog and/or digital telecommunications network, a packet-switch network, or a circuit-switched network. It will be appreciated from the preceding description, and for reasons of computational efficiency, that the components of the system can be arranged at any location within a distributed network of components without affecting the operation of the system. For example, the various components can be located in a switch such as a PBX and media server, gateway, in one or more communications devices, at one or more users' premises, or some combination thereof. Similarly, one or more functional portions of the system could be distributed between a telecommunications device(s) and an associated computing device.

[0196] Furthermore, it should be appreciated that the various links connecting the elements can be wired or wireless links, or any combination thereof, or any other known or later developed element(s) that is capable of supplying and/or communicating data to and from the connected elements. These wired or wireless links can also be secure links and may be capable of communicating encrypted information. Transmission media used as links, for example, can be any suitable carrier for electrical signals, including coaxial cables, copper wire and fiber optics, and may take the form of acoustic or light waves, such as those generated during radio-wave and infra-red data communications.

[0197] Also, while the flowcharts have been discussed and illustrated in relation to a particular sequence of events, it should be appreciated that changes, additions, and omissions to this sequence can occur without materially affecting the operation of the disclosed embodiments, configuration, and aspects.

[0198] A number of variations and modifications of the disclosure can be used. It would be possible to provide for some features of the disclosure without providing others.

[0199] In yet another embodiment, the systems and methods of this disclosure can be implemented in conjunction with a special purpose computer, a programmed microprocessor or microcontroller and peripheral integrated circuit element(s), an ASIC or other integrated circuit, a digital signal processor, a hard-wired electronic or logic circuit such as discrete

element circuit, a programmable logic device or gate array such as PLD, PLA, FPGA, PAL, special purpose computer, any comparable means, or the like. In general, any device(s) or means capable of implementing the methodology illustrated herein can be used to implement the various aspects of this disclosure. Exemplary hardware that can be used for the disclosed embodiments, configurations and aspects includes computers, handheld devices, telephones (e.g., cellular, Internet enabled, digital, analog, hybrids, and others), and other hardware known in the art. Some of these devices include processors (e.g., a single or multiple microprocessors), memory, nonvolatile storage, input devices, and output devices.

Furthermore, alternative software implementations including, but not limited to, distributed processing or component/object distributed processing, parallel processing, or virtual machine processing can also be constructed to implement the methods described herein.

[0200] In yet another embodiment, the disclosed methods may be readily implemented in conjunction with software using object or object-oriented software development environments that provide portable source code that can be used on a variety of computer or workstation platforms. Alternatively, the disclosed system may be implemented partially or fully in hardware using standard logic circuits or VLSI design. Whether software or hardware is used to implement the systems in accordance with this disclosure is dependent on the speed and/or efficiency requirements of the system, the particular function, and the particular software or hardware systems or microprocessor or microcomputer systems being utilized.

[0201] In yet another embodiment, the disclosed methods may be partially implemented in software that can be stored on a storage medium, executed on programmed general-purpose computer with the cooperation of a controller and memory, a special purpose computer, a microprocessor, or the like. In these instances, the systems and methods of this disclosure can be implemented as program embedded on personal computer such as an applet, JAVA® or CGI script, as a resource residing on a server or computer workstation, as a routine embedded in a dedicated measurement system, system component, or the like. The system can also be implemented by physically incorporating the system and/or method into a software and/or hardware system.

[0202] Although the present disclosure describes components and functions implemented in the aspects, embodiments, and/or configurations with reference to particular standards and protocols, the aspects, embodiments, and/or configurations are not limited to such standards and protocols. Other similar standards and protocols not mentioned herein are in existence and are considered to be included in the present disclosure. Moreover, the standards and

protocols mentioned herein and other similar standards and protocols not mentioned herein are periodically superseded by faster or more effective equivalents having essentially the same functions. Such replacement standards and protocols having the same functions are considered equivalents included in the present disclosure.

[0203] The present disclosure, in various aspects, embodiments, and/or configurations, includes components, methods, processes, systems and/or apparatus substantially as depicted and described herein, including various aspects, embodiments, configurations embodiments, subcombinations, and/or subsets thereof. Those of skill in the art will understand how to make and use the disclosed aspects, embodiments, and/or configurations after understanding the present disclosure. The present disclosure, in various aspects, embodiments, and/or configurations, includes providing devices and processes in the absence of items not depicted and/or described herein or in various aspects, embodiments, and/or configurations hereof, including in the absence of such items as may have been used in previous devices or processes, e.g., for improving performance, achieving ease and/or reducing cost of implementation.

[0204] The foregoing discussion has been presented for purposes of illustration and description. The foregoing is not intended to limit the disclosure to the form or forms disclosed herein. In the foregoing Detailed Description for example, various features of the disclosure are grouped together in one or more aspects, embodiments, and/or configurations for the purpose of streamlining the disclosure. The features of the aspects, embodiments, and/or configurations of the disclosure may be combined in alternate aspects, embodiments, and/or configurations other than those discussed above. This method of disclosure is not to be interpreted as reflecting an intention that the claims require more features than are expressly recited in each claim. Rather, as the following claims reflect, inventive aspects lie in less than all features of a single foregoing disclosed aspect, embodiment, and/or configuration. Thus, the following claims are hereby incorporated into this Detailed Description, with each claim standing on its own as a separate preferred embodiment of the disclosure.

[0205] Moreover, though the description has included description of one or more aspects, embodiments, and/or configurations and certain variations and modifications, other variations, combinations, and modifications are within the scope of the disclosure, e.g., as may be within the skill and knowledge of those in the art, after understanding the present disclosure. It is intended to obtain rights which include alternative aspects, embodiments, and/or configurations to the extent permitted, including alternate, interchangeable and/or

equivalent structures, functions, ranges or steps to those claimed, whether or not such alternate, interchangeable and/or equivalent structures, functions, ranges or steps are disclosed herein, and without intending to publicly dedicate any patentable subject matter.

What is claimed is:

1. A method of managing Electronic Programming Guide (EPG) information for an Intelligent television (TV), comprising:

polling and retrieving a plurality of EPG sources for updated EPG information;
aggregating the EPG information from the plurality of EPG sources; and
providing a relevant portion of the EPG information to an application of the Intelligent TV.

2. The method of claim 1, wherein for an EPG source with substantially no updated EPG information, the polling and retrieving step comprises associating the EPG information from the EPG source with dummy EPG data.

3. The method of claim 1, wherein the polling and retrieving step is activated by the Intelligent TV at a default or user-defined interval.

4. The method of claim 1, wherein the polling and retrieving step is activated after a channel scanning operation by the Intelligent TV.

5. The method of claim 1, wherein the polling and retrieving step comprises sending to an Internet or cloud EPG source a channel name list of the Intelligent TV and retrieving EPG information from the Internet or cloud EPG source that matches channels in the channel name list.

6. The method of claim 1, wherein the polling and retrieving step further comprises retrieving EPG information for only selected programs and/or channels from the EPG sources.

7. The method of claim 1, wherein the aggregating step comprises aggregating the updated EPG information from the plurality of EPG sources and resolving conflicts between duplicate EPG information from the plurality of EPG sources according to a plurality of rules.

8. The method of claim 7, wherein the resolving conflicts step comprises using EPG information from a first EPG source as a primary source and overwriting conflicting EPG information from the primary source with a second EPG source that is considered more reliable.

9. An EPG data service for an Intelligent TV, comprising:
a plurality of source plugins configured to poll and retrieve updated EPG information from a plurality of respective EPG information sources; and

an EPG subservice configured to receive the EPG information retrieved by the plurality of source plugins, aggregate the EPG information, and provide a relevant portion of the EPG information to an application of the Intelligent TV.

10. The EPG data service of claim 9, wherein, for an EPG source with substantially no updated EPG information, the respective source plugin is configured to associate EPG information from the EPG source with dummy EPG data.

11. The EPG data service of claim 9, wherein one or more of the plurality of source plugins is configured to poll and retrieve the updated EPG information at a default or user-defined interval.

12. The EPG data service of claim 9, one or more of the plurality of source plugins is configured to poll and retrieve the updated EPG information after a channel scanning operation by the Intelligent TV.

13. The EPG data service of claim 9, wherein an Internet or cloud source plugin of the plurality of source plugins is configured to send to an Internet or cloud EPG source a channel name list of the Intelligent TV and retrieving EPG information from the Internet or cloud EPG source that matches channels in the channel name list.

14. The EPG data service of claim 9, wherein one or more of the plurality of source plugins are configured to poll and retrieve the updated EPG information for only selected programs and/or channels from the EPG sources.

15. The EPG data service of claim 9, the EPG subservice is configured to aggregate the updated EPG information from the plurality of EPG sources and resolve conflicts between duplicate EPG information from the plurality of EPG sources according to a plurality of rules.

16. The EPG data service of claim 15, the EPG subservice is configured to resolve conflicts using EPG information from a first EPG source as a primary source and overwriting conflicting EPG information from the primary source with a second EPG source that is considered more reliable.

17. An Intelligent TV comprising:
an EPG display application configured to generate an EPG display for the Intelligent TV; and

an EPG data service, the EPG data service comprises a plurality of source plugins configured to poll and retrieve updated EPG information from a plurality of respective EPG information sources and an EPG subservice configured to receive the EPG information

retrieved by the plurality of source plugins, aggregate the EPG information, and provide a relevant portion of the EPG information to the EPG display application.

18. The EPG display of claim 1, wherein one or more of the plurality of source plugins are configured to poll and retrieve the updated EPG information at a default or user-defined interval.

19. The EPG display of claim 1, wherein an Internet or cloud source plugin of the plurality of source plugins are configured send to an Internet or cloud EPG source a channel name list of the Intelligent TV and retrieving EPG information from the Internet or cloud EPG source that matches channels in the channel name list.

20. A tangible and non-transient computer readable medium comprising microprocessor executable instructions that, when executed by the microprocessor, perform the steps of claim 1.

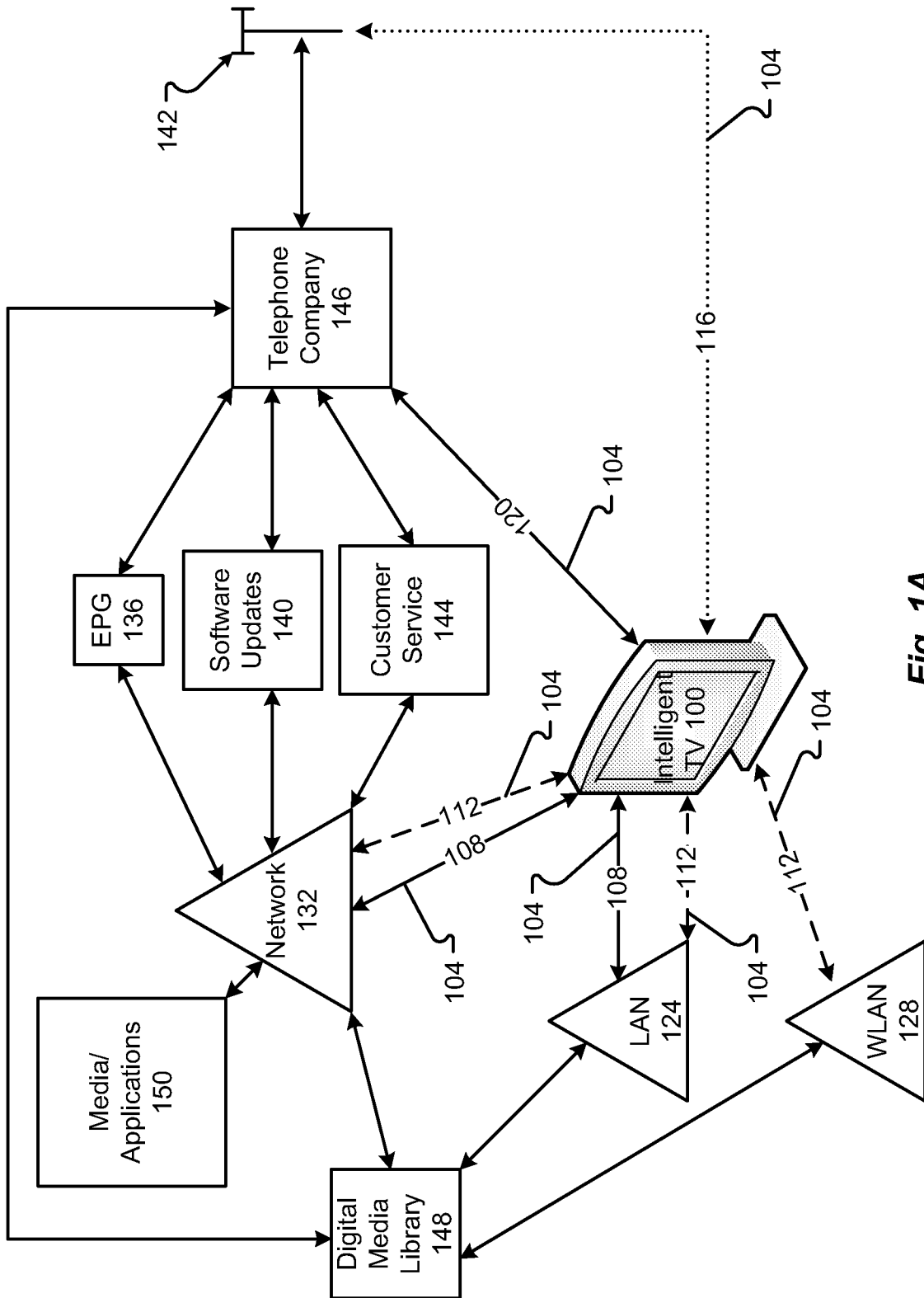

Fig. 1A

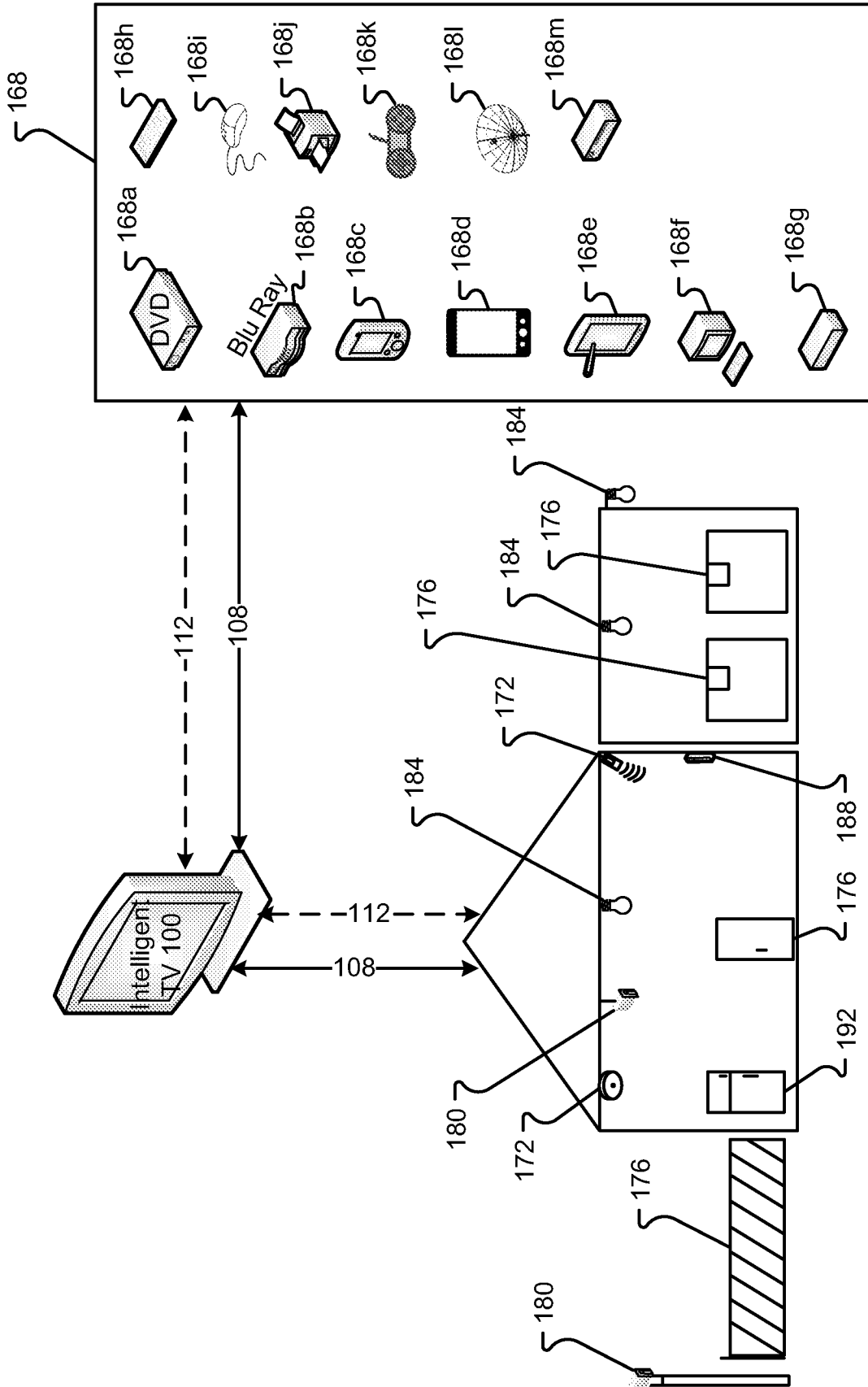

Fig. 1B

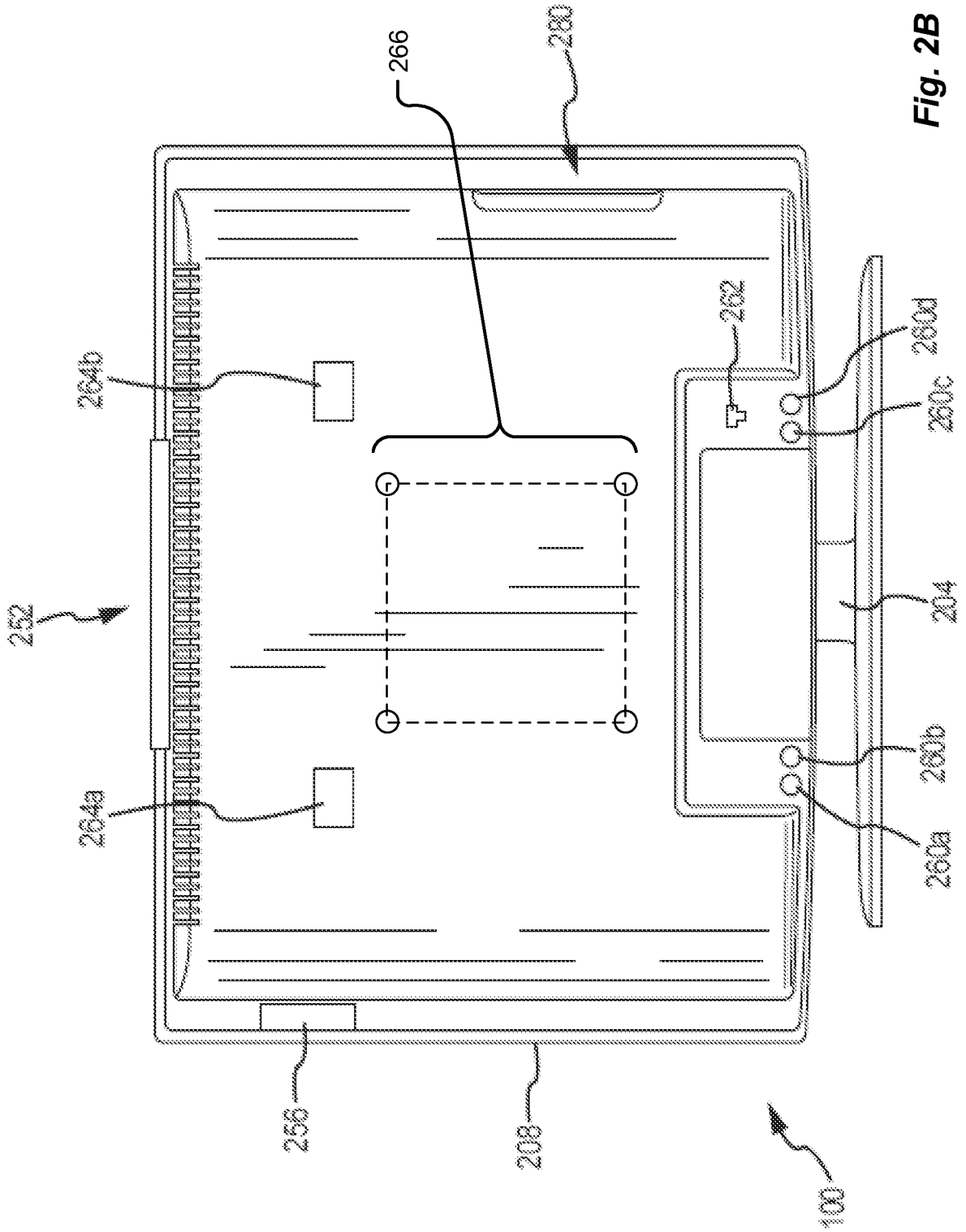

Fig. 2B

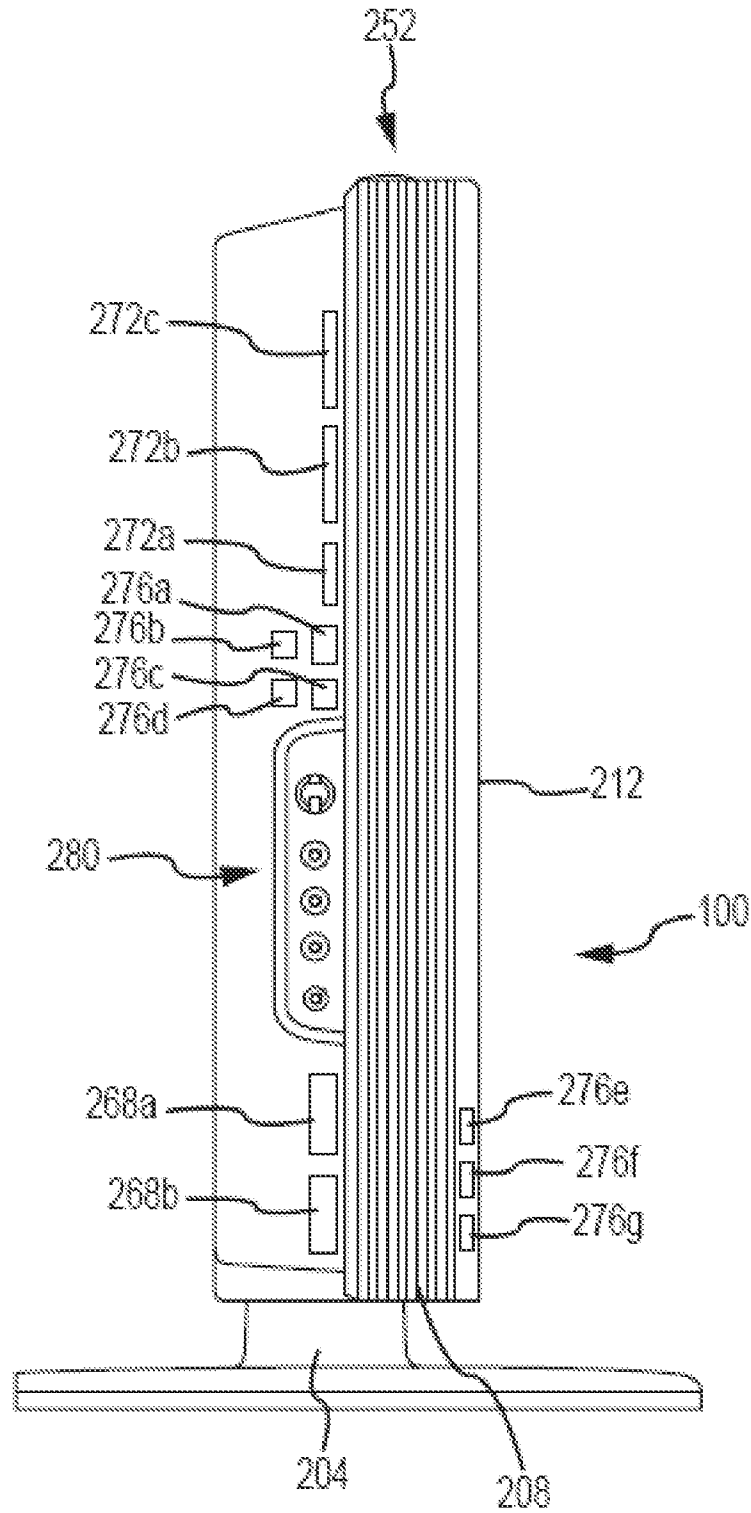

Fig. 2C

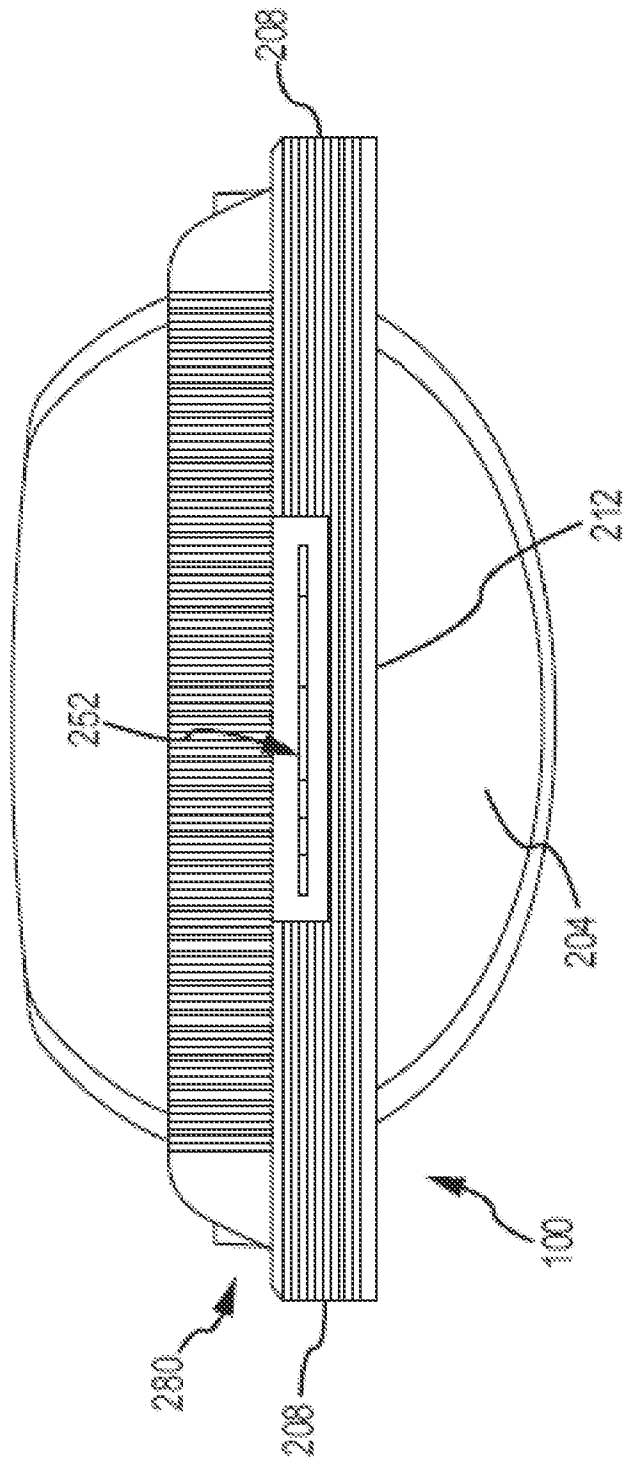

Fig. 2D

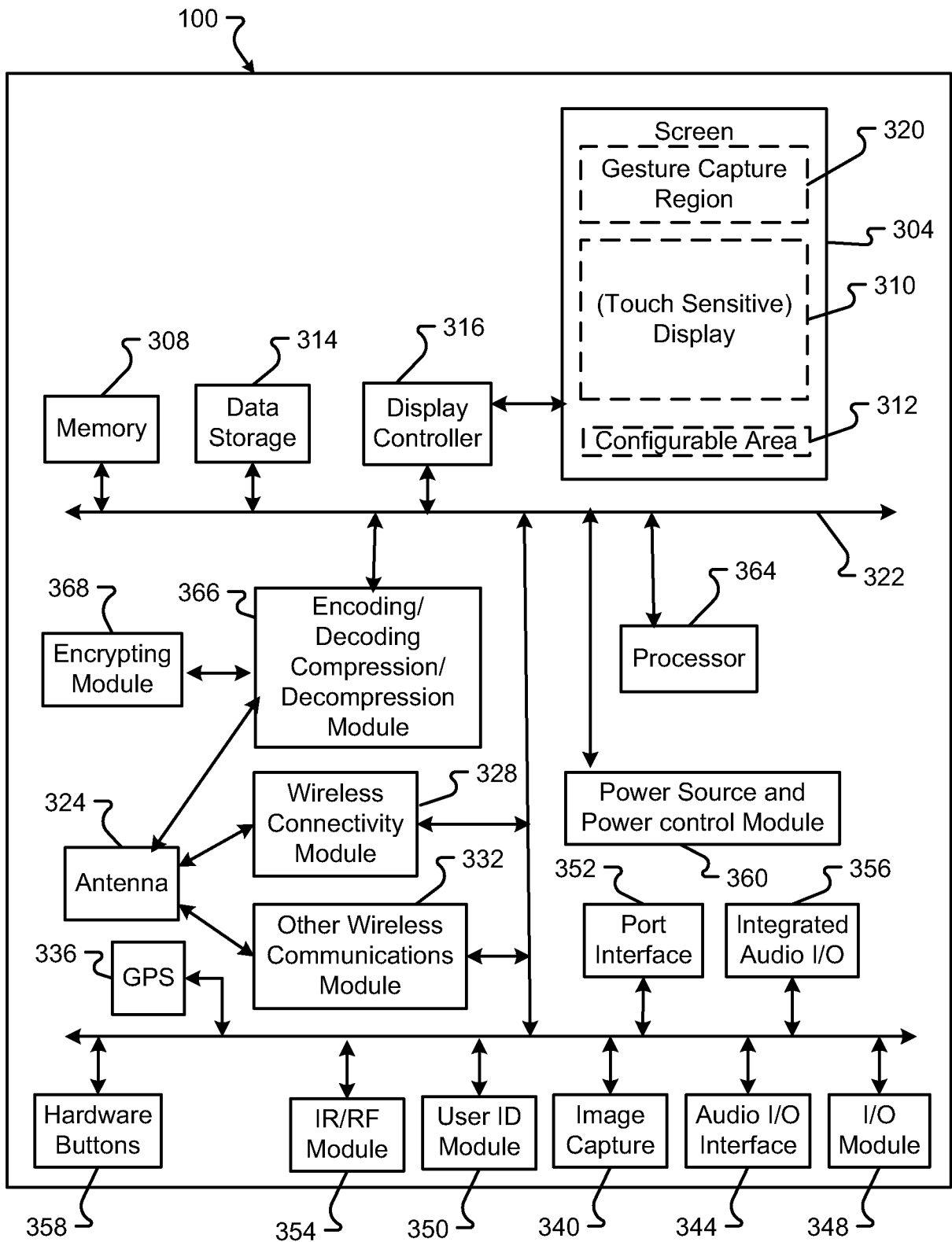

FIG. 3

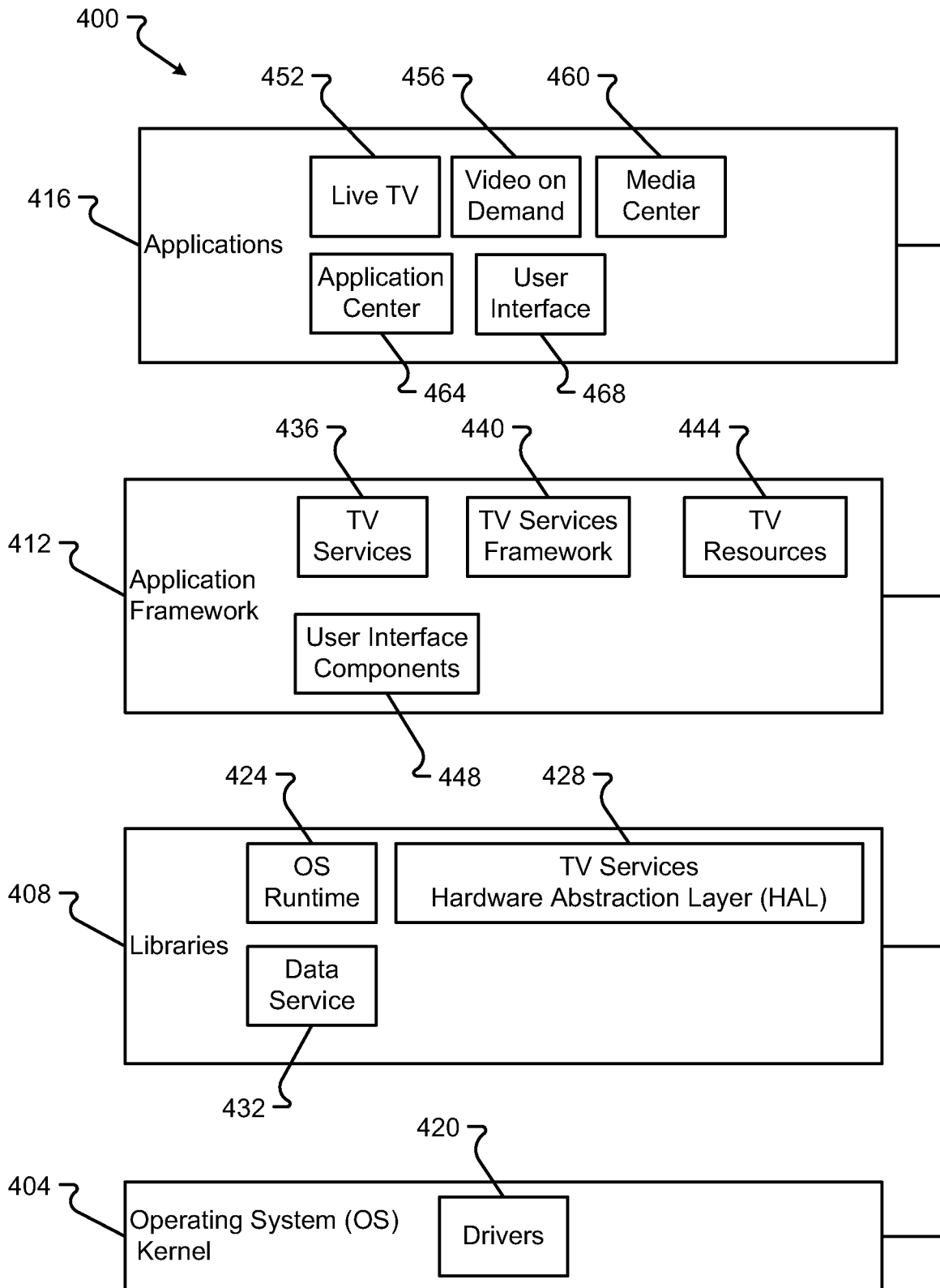

FIG. 4

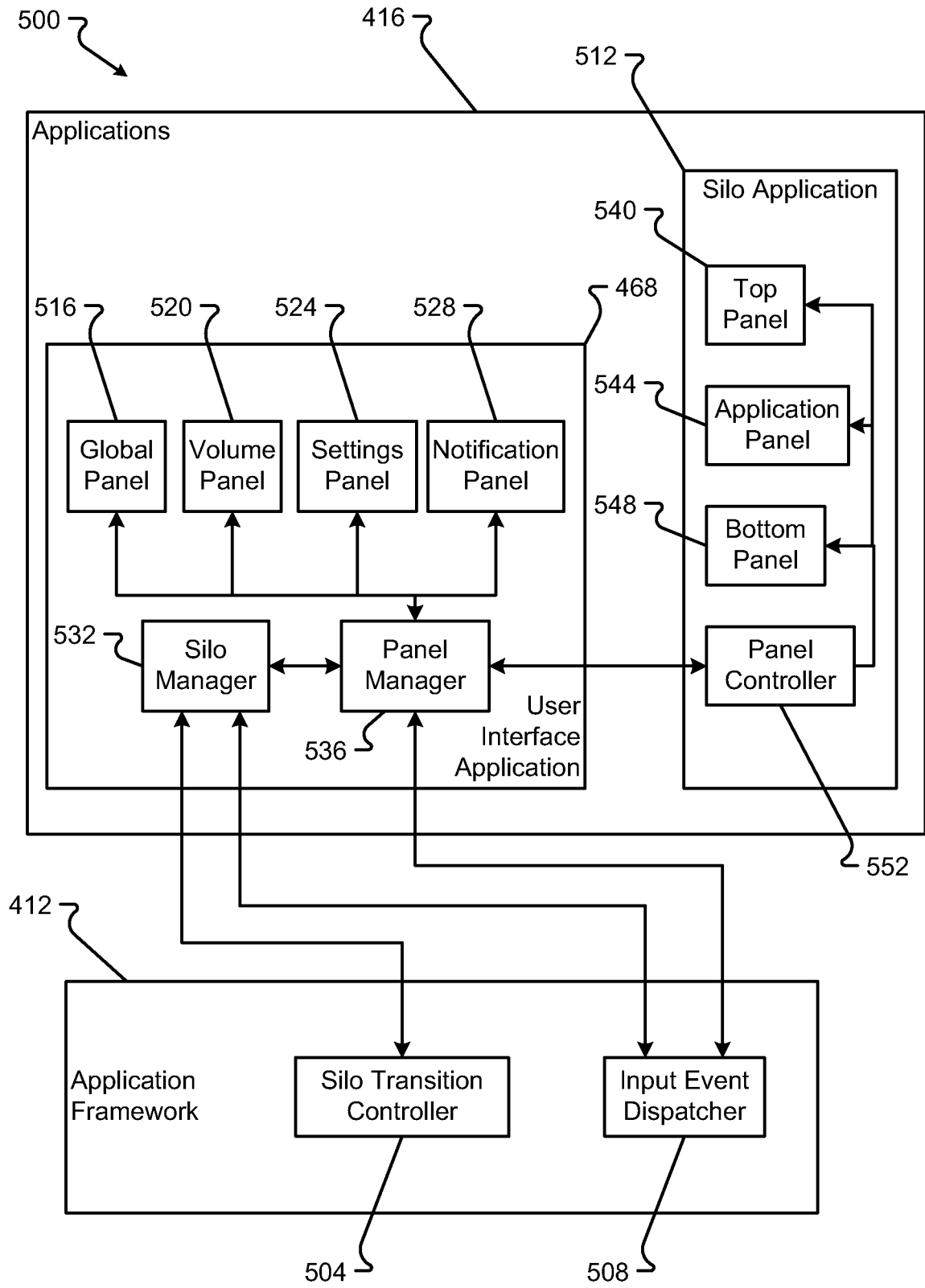

FIG. 5

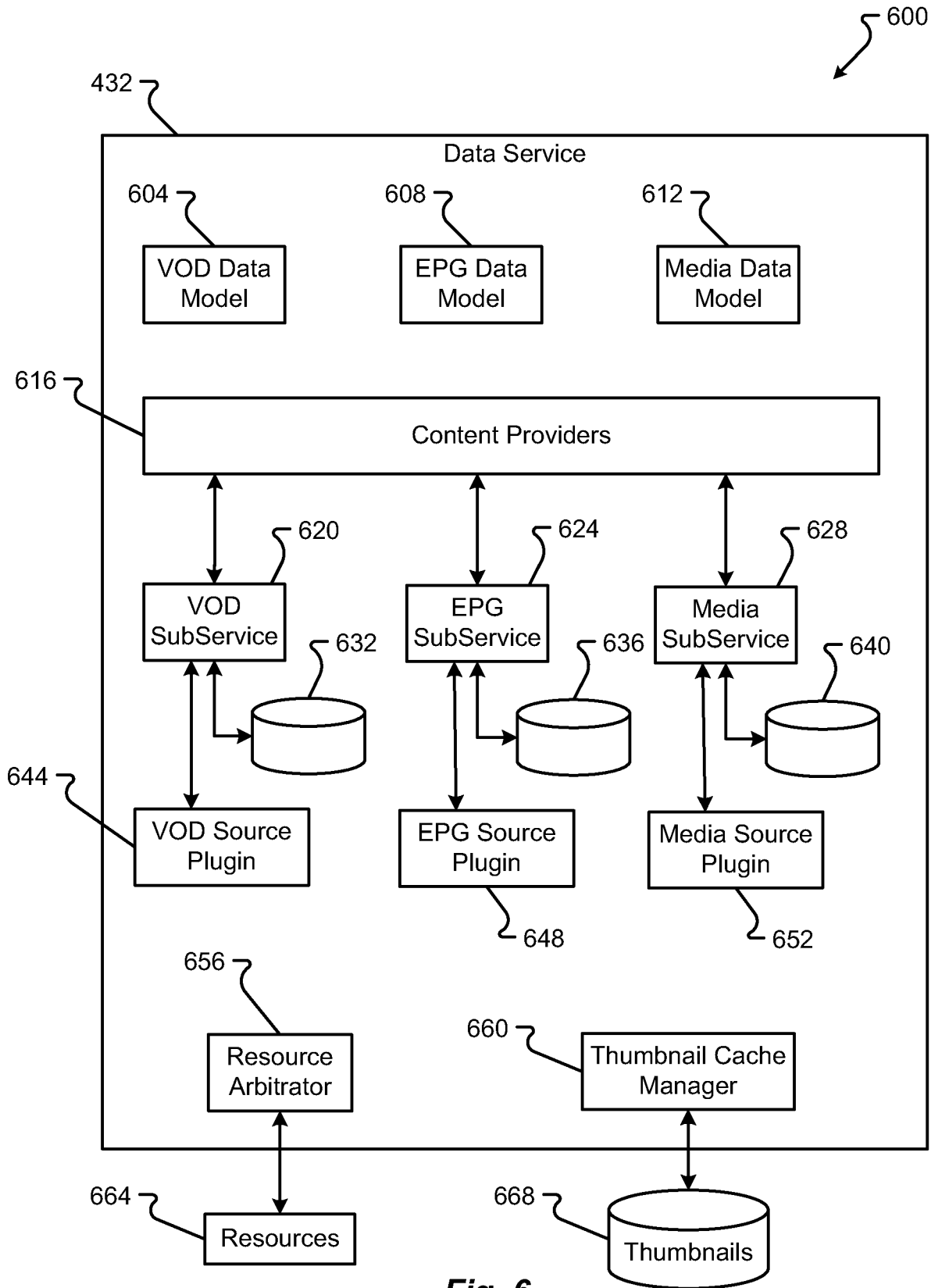

Fig. 6

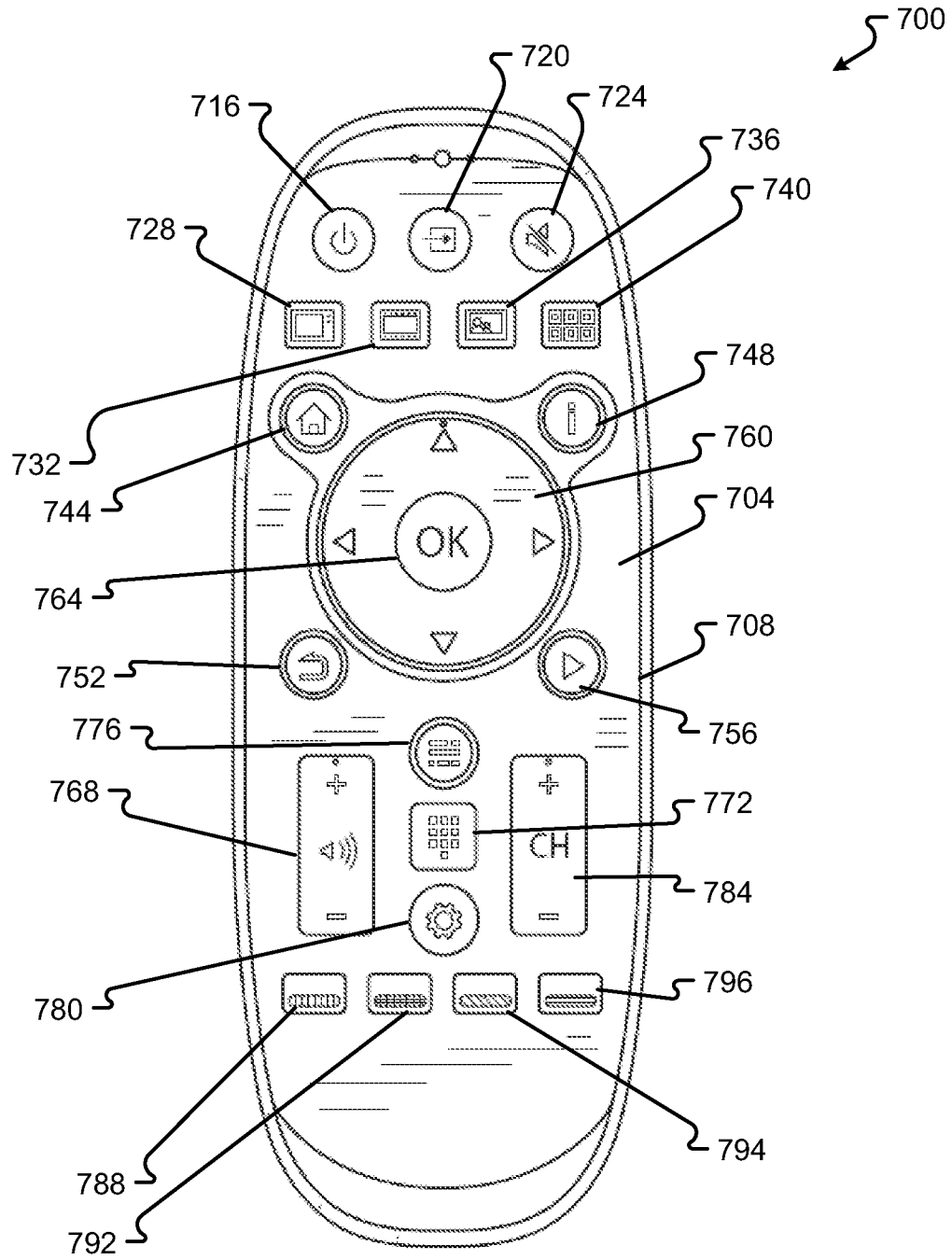

Fig. 7

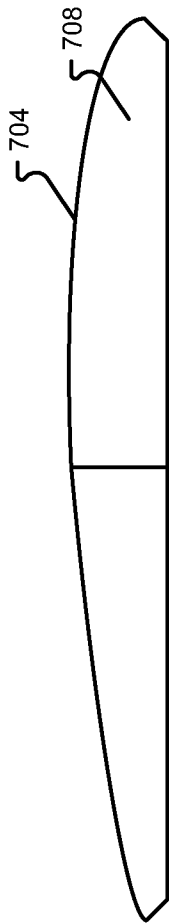

Fig. 8

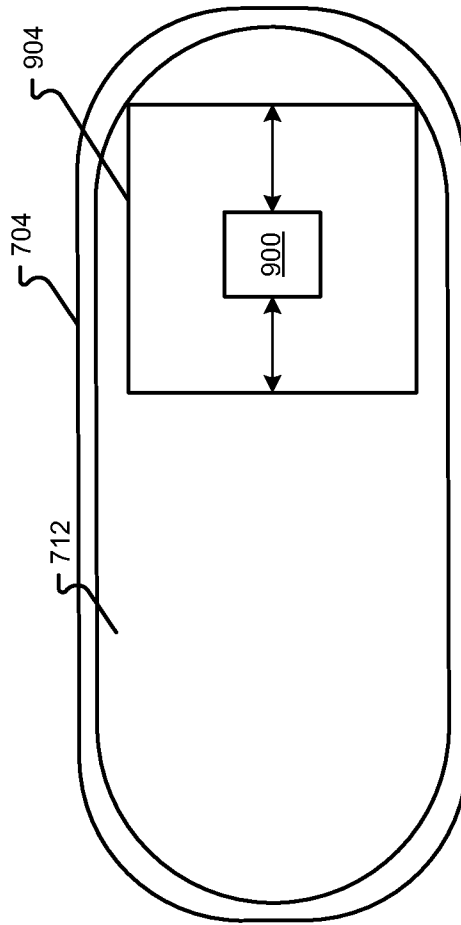

Fig. 9A

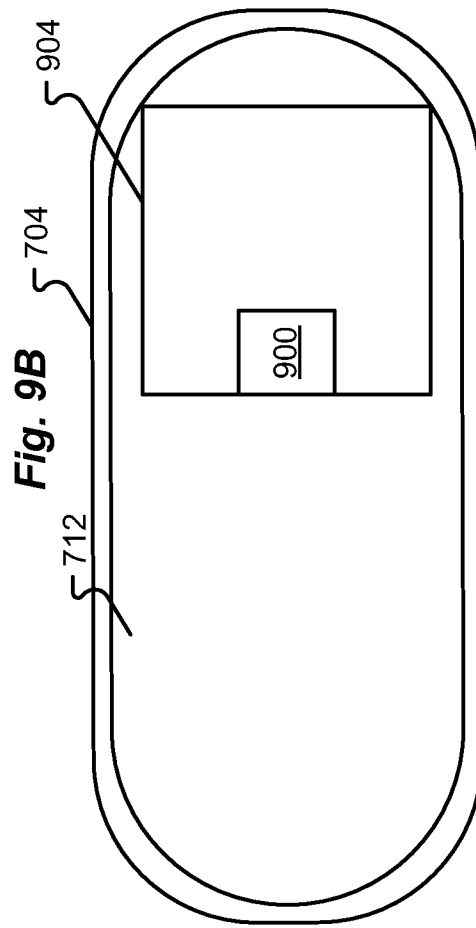
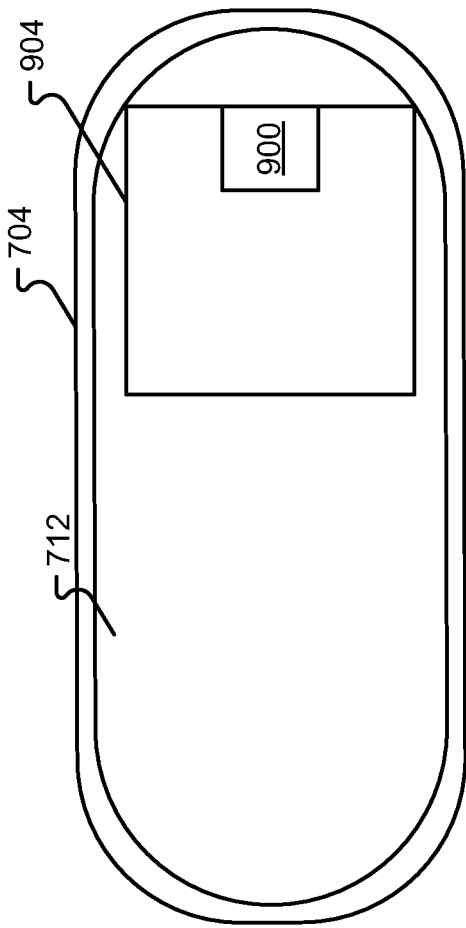

Fig. 9C

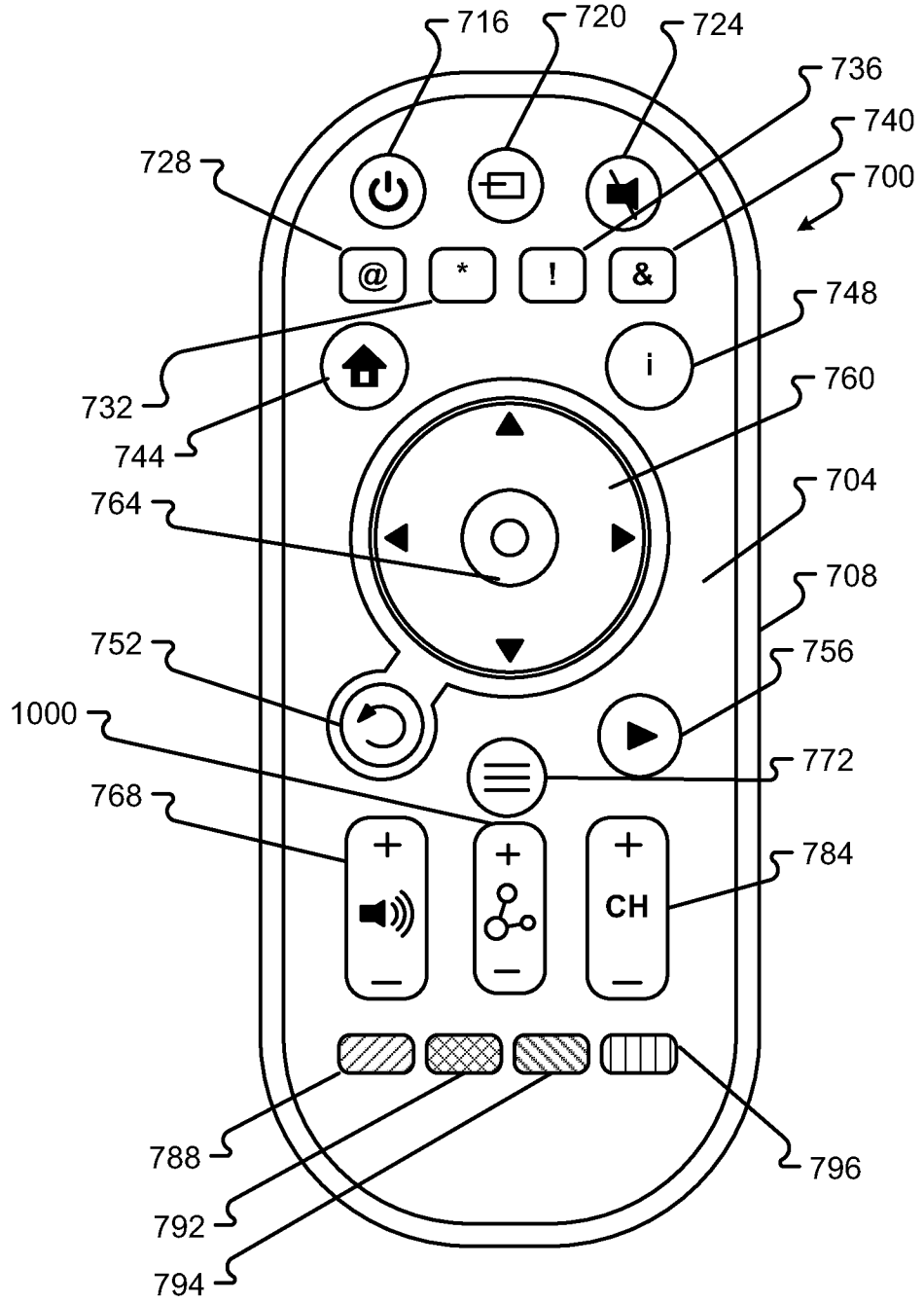

Fig. 10

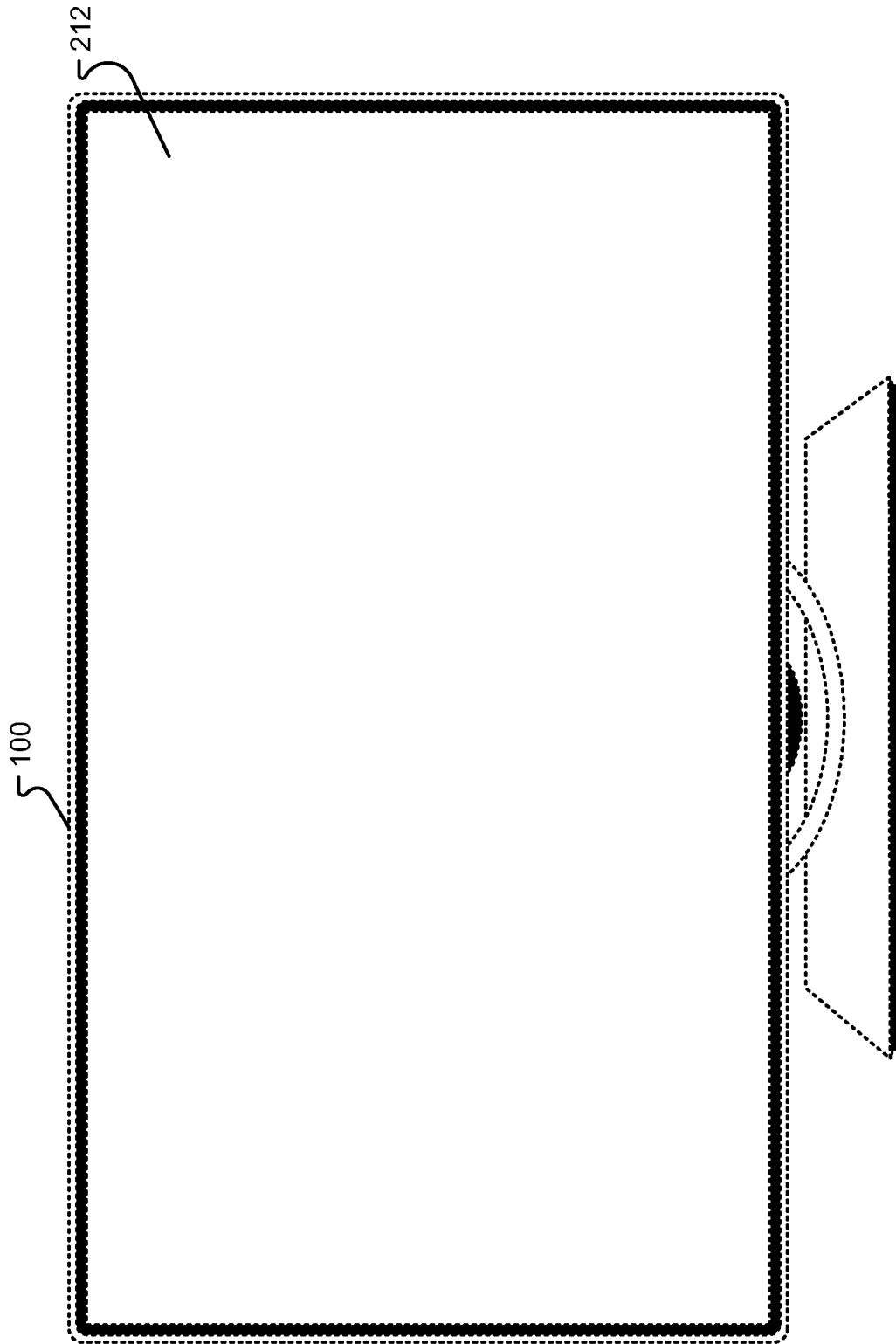

Fig. 11A

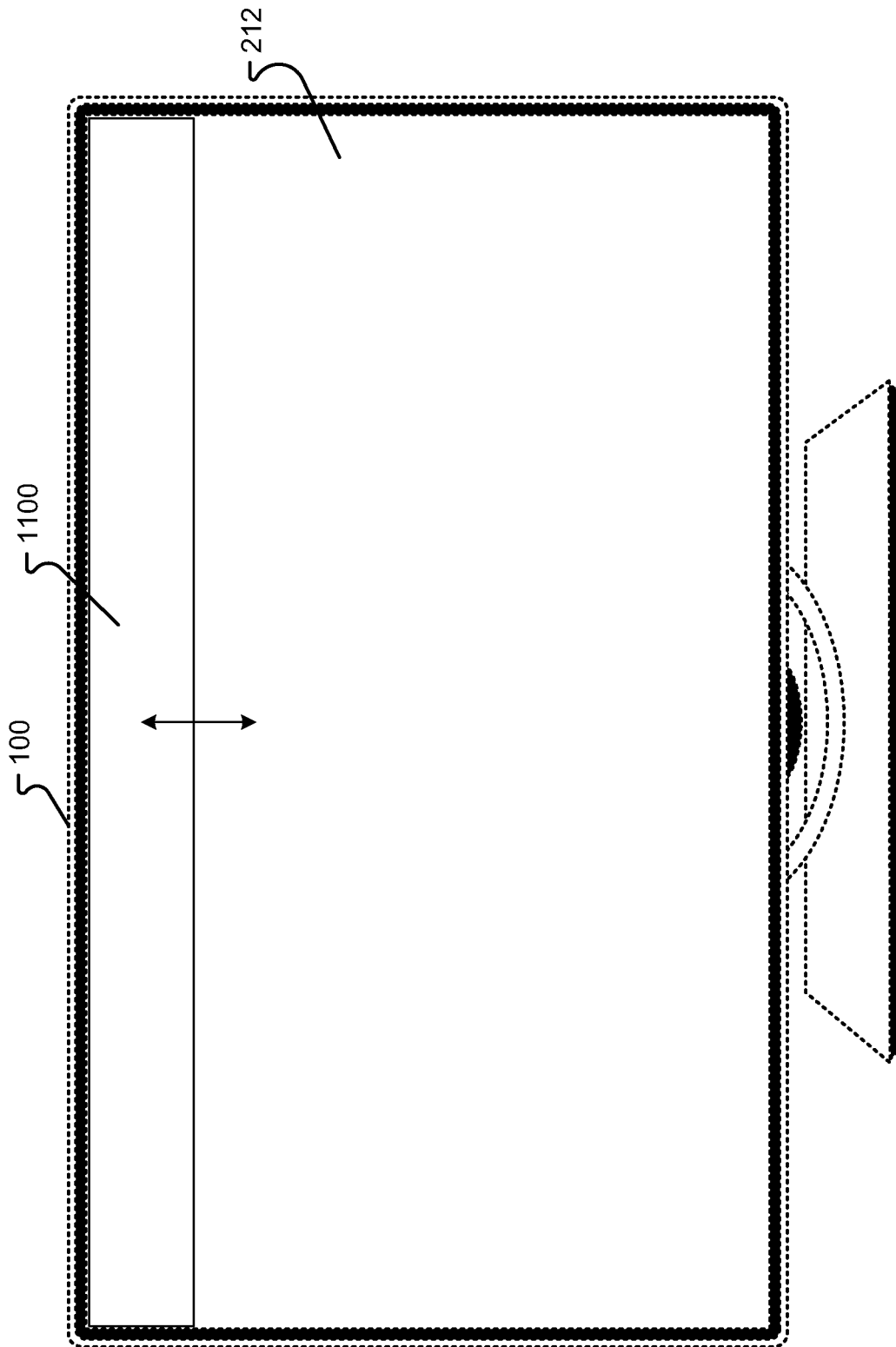

Fig. 11B

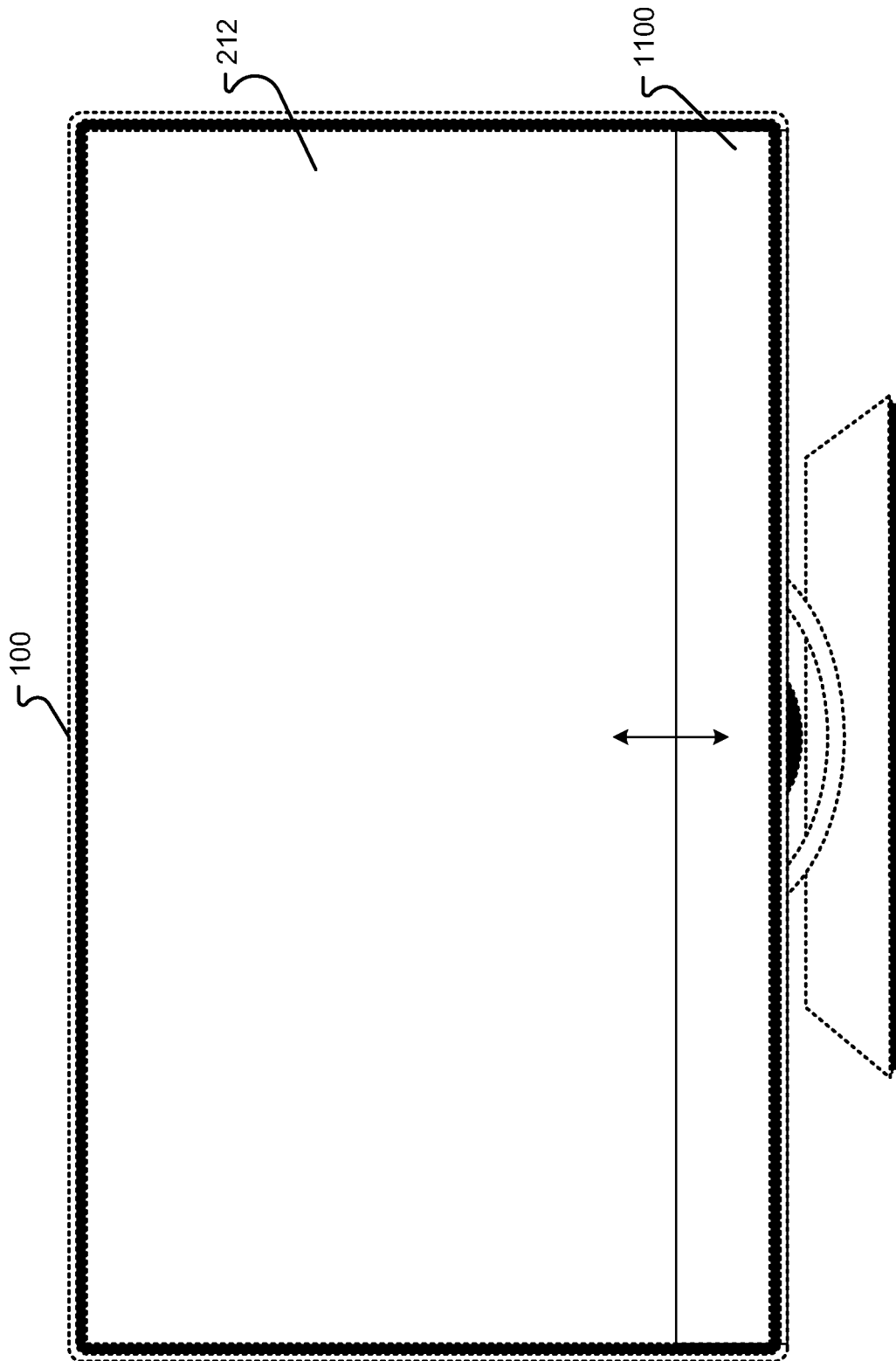

Fig. 11C

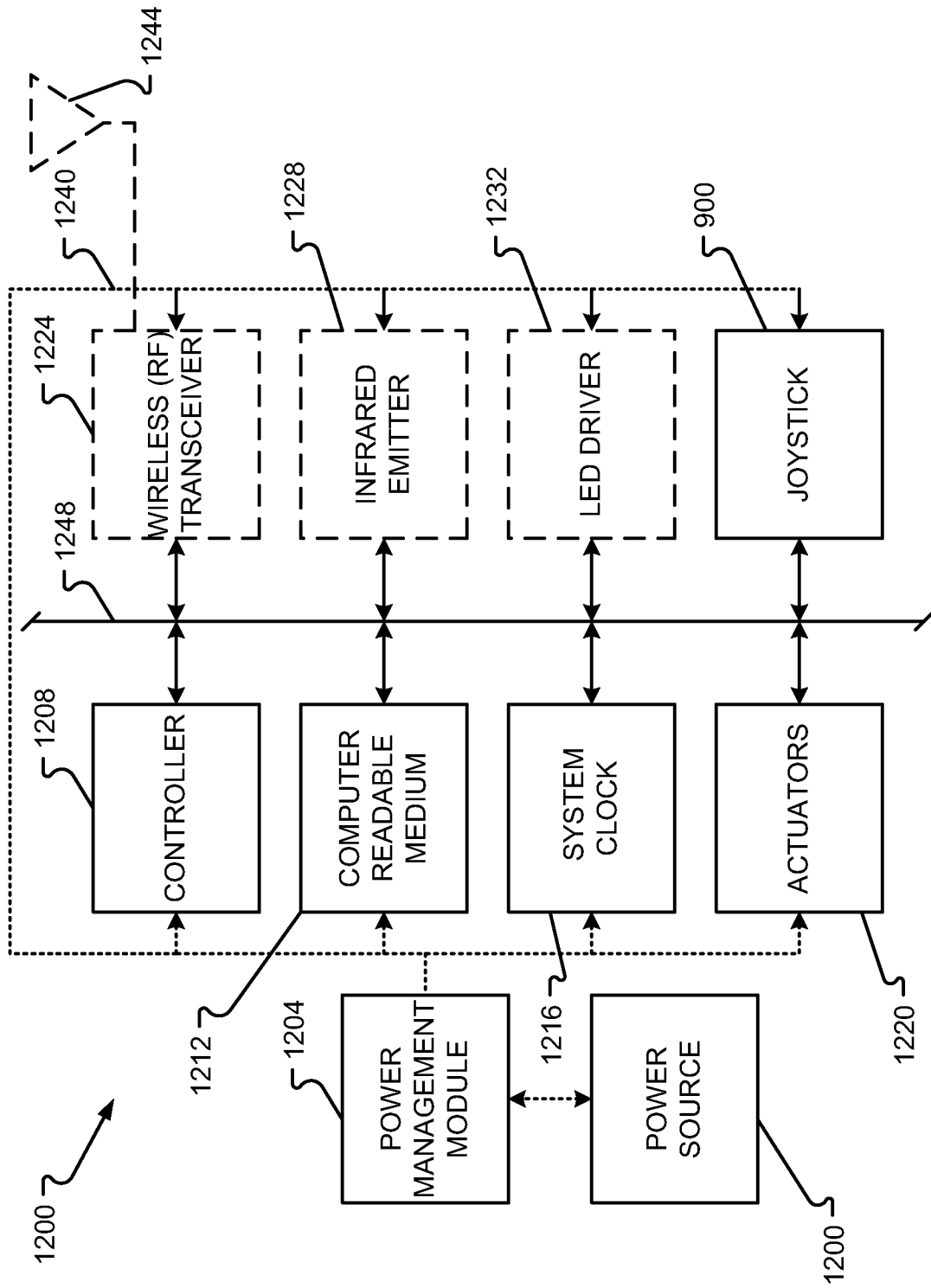

Fig. 12

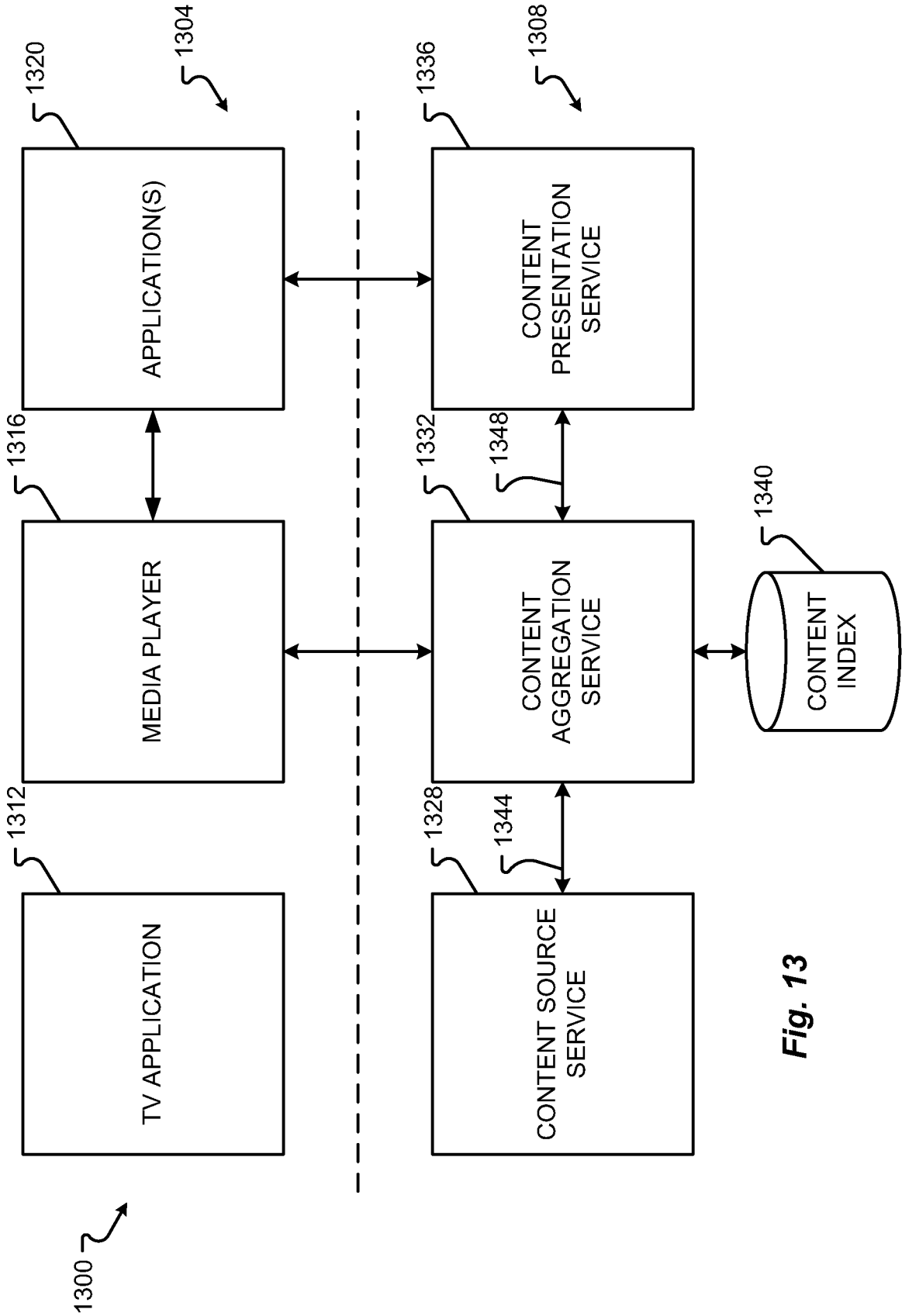

Fig. 13

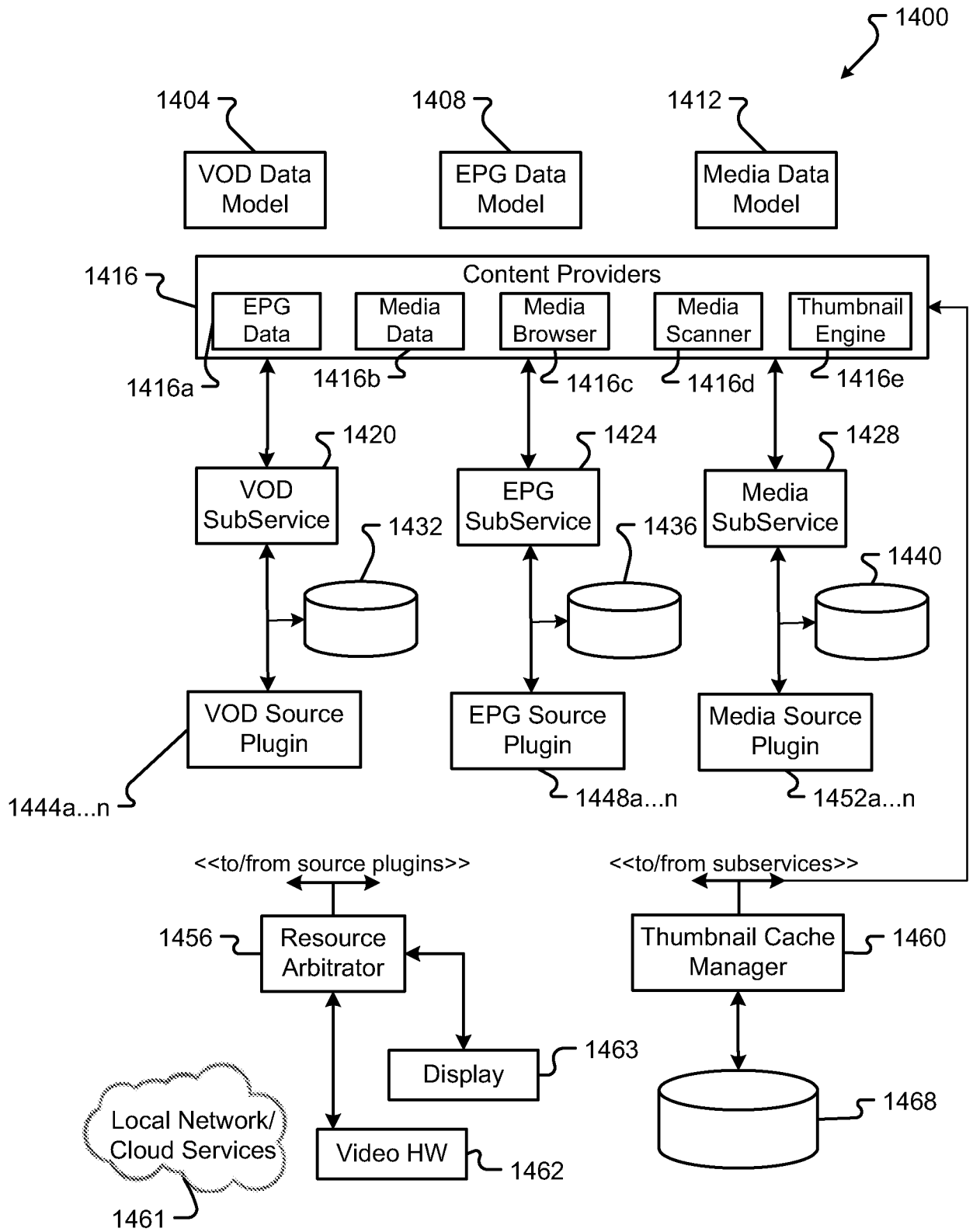

Fig. 14

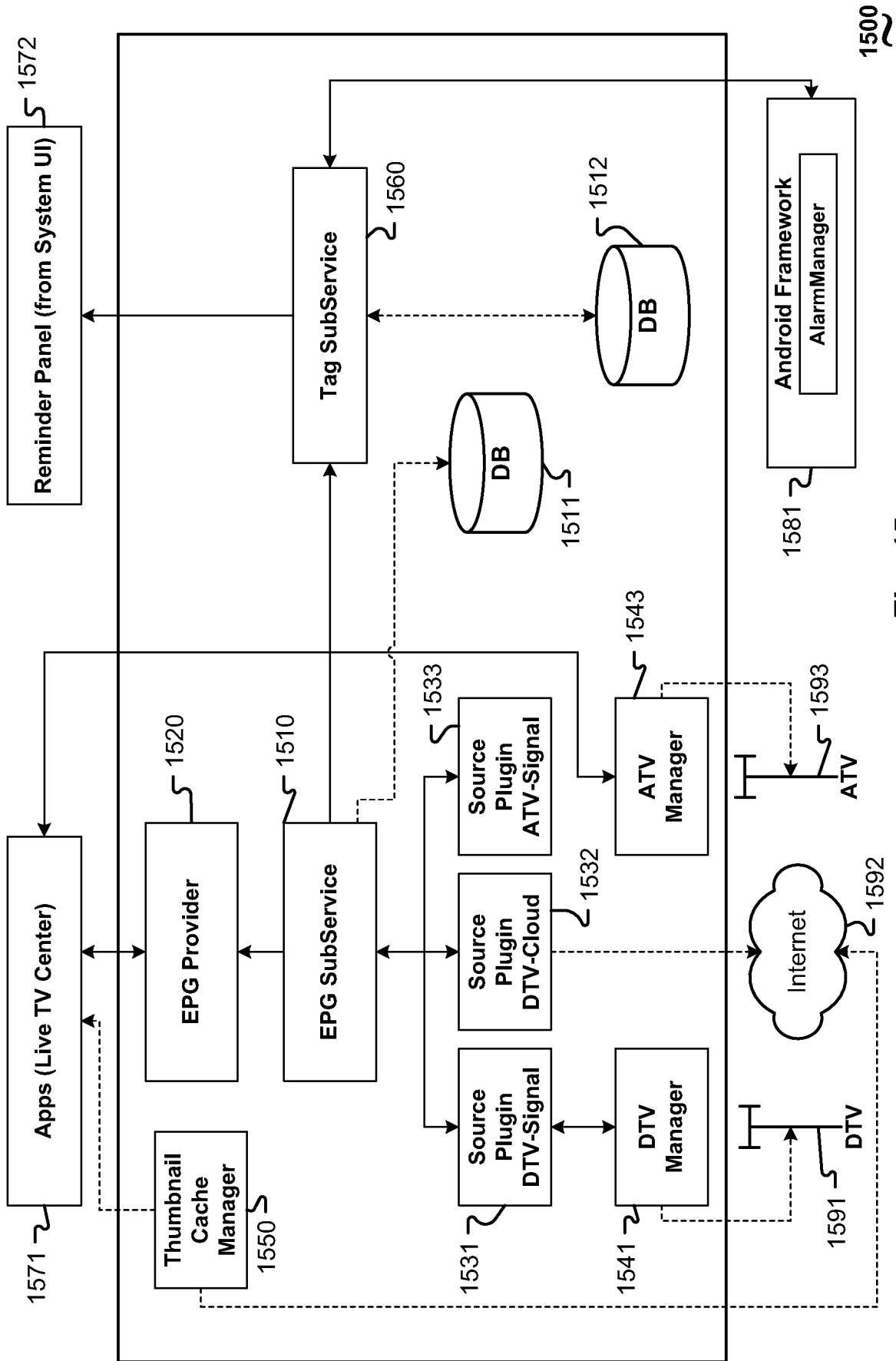

Fig. 15

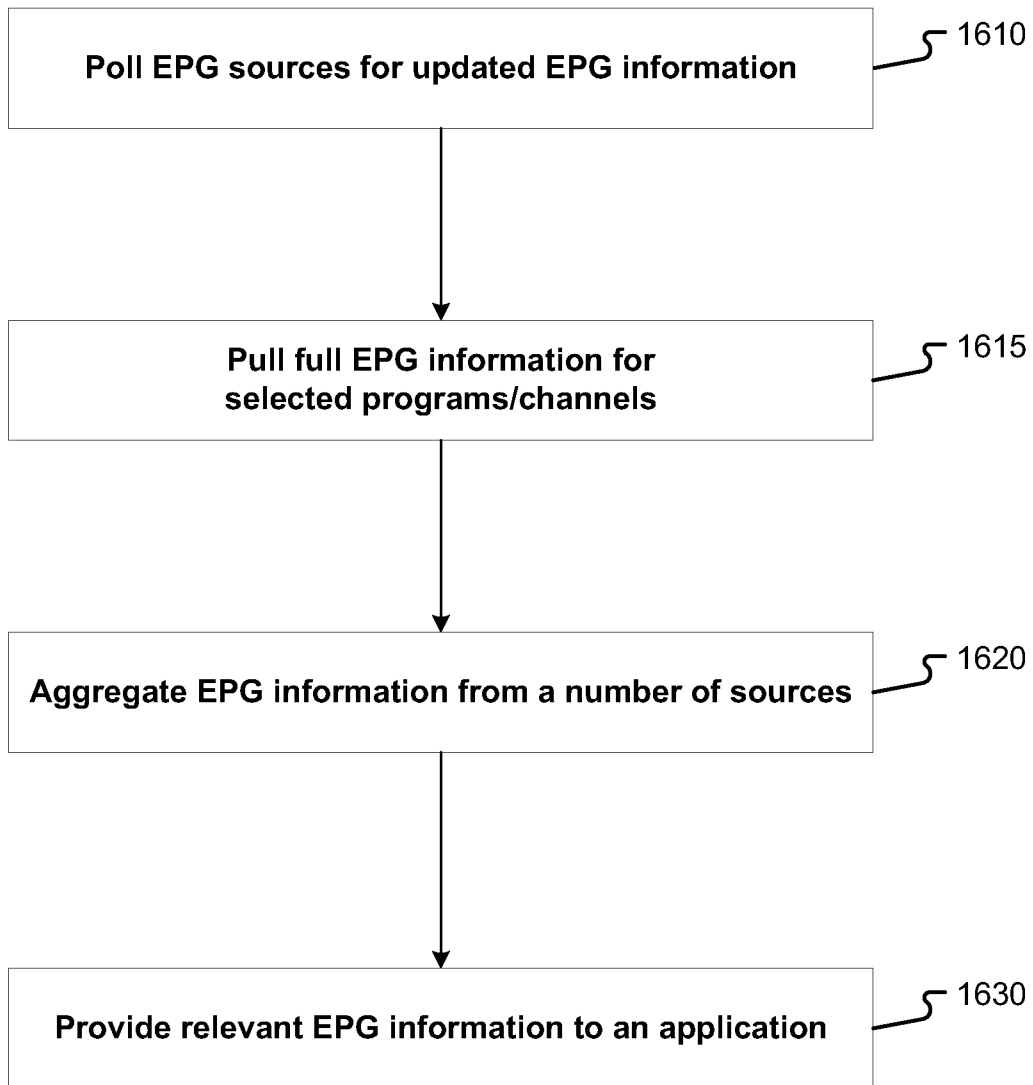

FIG. 16

1600
~

INTERNATIONAL SEARCH REPORT

International application No.

PCT/US13/55564

A. CLASSIFICATION OF SUBJECT MATTER IPC(8) - H04N 7/00 (2013.01) USPC - 725/141 According to International Patent Classification (IPC) or to both national classification and IPC		
B. FIELDS SEARCHED Minimum documentation searched (classification system followed by classification symbols) IPC(8): G06F 3/048; H04N 7/00 (2013.01) USPC: 715/854; 725/55, 141 Documentation searched other than minimum documentation to the extent that such documents are included in the fields searched Electronic data base consulted during the international search (name of data base and, where practicable, search terms used) MicroPatent (US-G, US-A, EP-A, EP-B, WO, JP-bib, DE-C,B, DE-A, DE-T, DE-U, GB-A, FR-A); Google Scholar; IEEE; DialogPRO; television, intelligent, TV, smart, interactive, high-definition, HDTV, aggregate, combine, sum, electronic, programming, guide, EPG, poll, search, collect, update, modify, change, manage, control, relevant, related, retrieve		
C. DOCUMENTS CONSIDERED TO BE RELEVANT		
Category*	Citation of document, with indication, where appropriate, of the relevant passages	Relevant to claim No.
X	US 2012/0174039 A1 (RHOADS J et al.) July 5, 2012, paragraphs [0025], [0028]-[0035], [0043], [0053], [0075], [0077], [0127], [0128], [0131], [0145], [0148]	1-20
<input type="checkbox"/> Further documents are listed in the continuation of Box C. <input type="checkbox"/>		
* Special categories of cited documents: "A" document defining the general state of the art which is not considered to be of particular relevance "E" earlier application or patent but published on or after the international filing date "L" document which may throw doubts on priority claim(s) or which is cited to establish the publication date of another citation or other special reason (as specified) "O" document referring to an oral disclosure, use, exhibition or other means "P" document published prior to the international filing date but later than the priority date claimed "T" later document published after the international filing date or priority date and not in conflict with the application but cited to understand the principle or theory underlying the invention "X" document of particular relevance; the claimed invention cannot be considered novel or cannot be considered to involve an inventive step when the document is taken alone "Y" document of particular relevance; the claimed invention cannot be considered to involve an inventive step when the document is combined with one or more other such documents, such combination being obvious to a person skilled in the art "&" document member of the same patent family		
Date of the actual completion of the international search 14 November 2013 (14.11.2013)		Date of mailing of the international search report 22 NOV 2013
Name and mailing address of the ISA/US Mail Stop PCT, Attn: ISA/US, Commissioner for Patents P.O. Box 1450, Alexandria, Virginia 22313-1450 Facsimile No. 571-273-3201		Authorized officer: Shane Thomas PCT Helpdesk: 571-272-4300 PCT OSP: 571-272-7774