

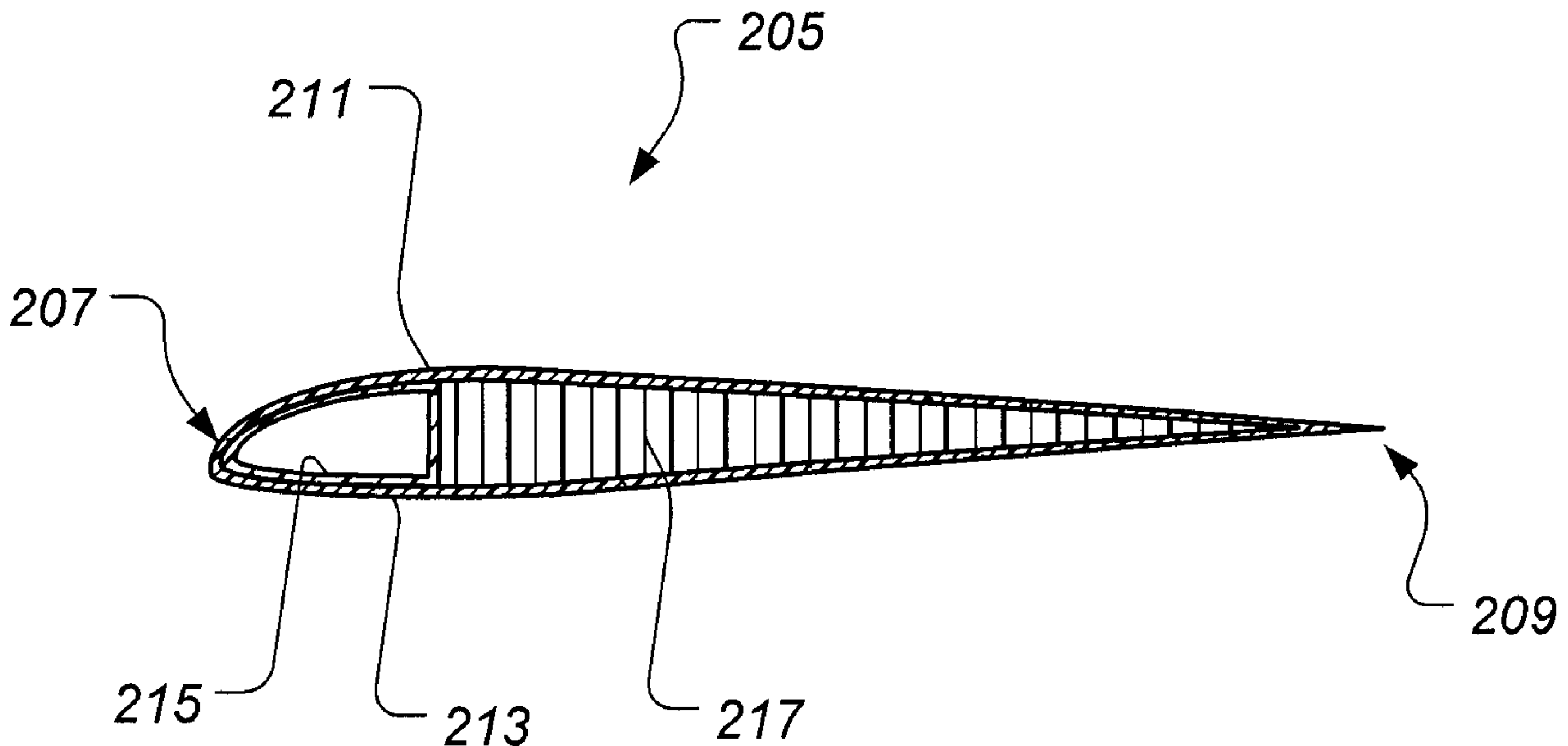

(22) **Date de dépôt/Filing Date:** 2013/10/22
 (41) **Mise à la disp. pub./Open to Public Insp.:** 2014/04/30
 (45) **Date de délivrance/Issue Date:** 2017/03/21
 (30) **Priorité/Priority:** 2012/10/30 (US13/664,010)

(51) **Cl.Int./Int.Cl.** *B29C 73/00* (2006.01),
B29C 44/16 (2006.01), *B64C 3/20* (2006.01)
 (72) **Inventeurs/Inventors:**
 THIAGARAJAN, RAMESH, US;
 INGRAM, THEODORE W., III, US;
 MCCULLOUGH, JOHN R., US;
 MISHRA, SUVANKAR, US;
 MAY, CARL, US
 (73) **Propriétaire/Owner:**
 BELL HELICOPTER TEXTRON INC., US
 (74) **Agent:** NORTON ROSE FULBRIGHT CANADA
 LLP/S.E.N.C.R.L., S.R.L.

(54) **Titre :** METHODE DE REPARATION, DE RACCORDEMENT, DE JOINTAGE, D'USINAGE ET DE STABILISATION D'UNE ALVEOLE AU MOYEN D'UNE MOUSSE STRUCTUREE VERSABLE ET STRUCTURE INTEGRANT CELLE-CI
 (54) **Title:** METHOD OF REPAIRING, SPLICING, JOINING, MACHINING, AND STABILIZING HONEYCOMB CORE USING POURABLE STRUCTURAL FOAM AND A STRUCTURE INCORPORATING THE SAME



(57) **Abrégé/Abstract:**

A core stiffened structure including a first skin, a second skin, and a core member having an expanded foam disposed within cell members. An attachment member is attached to the core stiffened structure through the first skin, the second skin, and the core member. The structure may form an aerodynamic structure of an aircraft. The structure may include an upper core member, a lower core member, a forward foam member bonded to a forward portion of the upper and lower core members and an aft foam member bonded to an aft portion of the upper and lower core members. Also, the structure may include an upper core member and a lower core member, with the upper core member including a plurality of cell member filled with structural foam.

Abstract

A core stiffened structure including a first skin, a second skin, and a core member having an expanded foam disposed within cell members. An attachment member is attached to the core stiffened structure through the first skin, the second skin, and the core member. The structure may form an aerodynamic structure of an aircraft. The structure may include an upper core member, a lower core member, a forward foam member bonded to a forward portion of the upper and lower core members and an aft foam member bonded to an aft portion of the upper and lower core members. Also, the structure may include an upper core member and a lower core member, with the upper core member including a plurality of cell member filled with structural foam.

**METHOD OF REPAIRING, SPLICING, JOINING, MACHINING, AND STABILIZING
HONEYCOMB CORE USING POURABLE STRUCTURAL FOAM AND A STRUCTURE
INCORPORATING THE SAME**

BACKGROUND

Technical Field:

One method of the present disclosure relates to using a pourable structural foam in the repair of a honeycomb core stiffened structure. Another method of the present disclosure relates to the splicing of honeycomb core using pourable structural foam. Another method of the present disclosure relates to the joining of honeycomb core to a structural with the use of structural foam. Another method of the present disclosure relates to using structural foam to provide stability to honeycomb core during a machining process. One apparatus of the present disclosure includes a core stiffened structure. Another method of the present disclosure relates to the utilization of structural foam for the stabilizing of honeycomb core during an autoclave curing cycle.

Description of Related Art:

In a conventional repair process, a damaged core stiffened structure is repaired by removal/replacement of the damaged honeycomb core with new honeycomb core. Such a process can be expensive, time-consuming, and can require multiple curing and bonding processes. There is a need for an improved method of repairing a honeycomb core stiffened structure.

In a conventional honeycomb core splicing process, exposed cell walls are meticulously bonded to adjacent exposed cell walls of another honeycomb core with an adhesive. Such a process can be expensive, time-consuming, and can require an adhesive cure cycle. Further, such a conventional process can be inadequate for splicing honeycomb core members having non-compatible materials. There is a need for an improved method of splicing portions of honeycomb core.

In a conventional honeycomb core joining process, exposed cell walls are joined to adjacent structure with an adhesive. Such a process can be expensive, time-consuming, and require

an adhesive cure cycle. There is a need for an improved method of joining honeycomb core to adjacent structure.

In a conventional honeycomb core machining process, the honeycomb core is machined to a desired contour at a feed rate low enough to prevent damage to the unstable honeycomb core. Such a process can be time-consuming. There is a need for an improved method of machining honeycomb core, especially for large cell carbon prepreg core.

In a conventional curing cycle of the honeycomb core stiffened structure, the autoclave pressure can cause the honeycomb core to crush unless a low bevel angle on the honeycomb core is used. Conventionally, if the geometry of the core stiffened panel did not allow for the low angle bevel, then the core stiffened panel would have to be manufacturing using labor intensive and procedures (multiple cure cycles) that can also add significant weight penalties. Hence there is a need for improved method of stabilizing honeycomb core during an autoclave cure cycle.

SUMMARY

In one aspect, there is provided a core stiffened structure comprising: a first skin; a second skin; and a core member having an expanded foam disposed within cell members; an attachment member attached to the core stiffened structure through the first skin, the second skin, and the core member.

In another aspect, there is provided a core stiffened structure forming an aerodynamic structure of an aircraft, the structure comprising: an upper skin; a lower skin; and an upper core member; a lower core member; a forward foam member bonded to a forward portion of the upper core member and a forward portion of the lower core member; an aft foam member bonded to an aft portion of the upper core member and an aft portion of the lower core member.

In a further aspect, there is provided a core stiffened structure for an aircraft, the core stiffened structure comprising: an outer skin; an inner skin; and an upper core member located approximate an upper portion between the outer skin and the inner skin; a lower core member located approximate a lower portion between the outer skin and the inner skin; wherein the upper core member includes a plurality of cell member filled with structural foam.

DESCRIPTION OF THE DRAWINGS

The novel features believed characteristic of the methods and apparatuses of the present disclosure are set forth in the appended claims. However, each method and apparatus, as well as a preferred mode of use, and further objectives and advantages thereof, will best be understood by reference to the following detailed description when read in conjunction with the accompanying drawings, wherein:

Figure 1 is a side view of a illustrative rotorcraft;

Figure 2 is a top view of a rotor blade, according to an illustrative embodiment;

Figure 3 is a cross-sectional view of the rotor blade, taken from section lines 3-3 in Figure 2;

Figure 4 is a schematic view of a method of repairing a honeycomb core stiffened structure, according to an illustrative embodiment;

Figure 5 is a top view of a portion of a rotor blade, for illustrative purposes;

Figure 6 is a top view of a portion of a rotor blade, for illustrative purposes;

Figure 7 is a top view of a portion of a rotor blade, for illustrative purposes;

Figure 8 is a stylized view of components of the foam system, according to an illustrative embodiment of present application;

Figure 9 is a front view of a mixer used to mix the foam system, according to an illustrative embodiment of present application;

Figure 10 is a stylized view of a mixture of the foam system, according to an illustrative embodiment of present application;

Figure 11A is a cross-sectional view of the rotor blade, taken from section lines 11A-11A in Figure 7;

Figure 11B is a cross-sectional view of the rotor blade, similar to Figure 11A;

Figure 12 is a schematic view of a method of splicing together one or more sections of core material, according to an illustrative embodiment;

Figure 13 is a top stylized view of a method of splicing together one or more sections of core material, according to an illustrative embodiment;

Figure 14 is a top stylized view of a method of splicing together one or more sections of core material, according to an illustrative embodiment;

Figure 15 is a top stylized view of a method of splicing together one or more sections of core material, according to an illustrative embodiment;

Figure 16 is a top stylized view of a method of splicing together one or more sections of core material, according to an illustrative embodiment;

Figure 17 is a schematic view of a method of joining together core material to a structure, according to an illustrative embodiment;

Figure 18 is a top stylized view of a method of joining together core material to a structure, according to an illustrative embodiment;

Figure 19 is a schematic view of a method of machining honeycomb core, according to an illustrative embodiment;

Figure 20 is a cross-sectional stylized view of a method of machining honeycomb core, according to an illustrative embodiment;

Figure 21 is a cross-sectional stylized view of a machined honeycomb core, according to an illustrative embodiment;

Figure 22 is a top view of a core stiffened structure, according to an illustrative embodiment;

Figure 23 is a front view of a core stiffened structure, according to an illustrative embodiment;

Figure 24 is a cross-sectional view of a core stiffened structure, taken at section lines 24-24 in Figure 22, according to an illustrative embodiment;

Figure 25 is a cross-sectional view of a core stiffened structure, according to an illustrative embodiment;

Figure 26 is a cross-sectional view of a core stiffened structure, according to an illustrative embodiment;

Figure 27 is a cross-sectional view of a core stiffened structure, according to an illustrative embodiment;

Figure 28 is a cross-sectional view of a core stiffened structure, according to an illustrative embodiment;

Figure 29 is a schematic view of a method of stabilizing honeycomb core for an autoclave cure cycle of a core stiffened structure, according to an illustrative embodiment;

Figure 30 is a top view of a core stiffened structure, according to an illustrative embodiment;

Figure 31 is a front view of a core stiffened structure, according to an illustrative embodiment;

Figure 32 is a cross-sectional view of a core stiffened structure, taken at section lines 32-32 in Figure 30, according to an illustrative embodiment;

Figure 33 is a cross-sectional stylized view of a method of stabilizing honeycomb core for an autoclave cure cycle of a core stiffened structure, according to an illustrative embodiment; and

Figure 34 is a cross-sectional stylized view of a method of stabilizing honeycomb core for an autoclave cure cycle of a core stiffened structure, according to an illustrative embodiment.

DETAILED DESCRIPTION

Illustrative embodiments of the methods and apparatuses are described below. In the interest of clarity, all features of an actual implementation may not be described in this specification. It will of course be appreciated that in the development of any such actual embodiment, numerous implementation-specific decisions must be made to achieve the developer's specific goals, such as compliance with system-related and business-related constraints, which will vary from one implementation to another. Moreover, it will be

appreciated that such a development effort might be complex and time-consuming but would nevertheless be a routine undertaking for those of ordinary skill in the art having the benefit of this disclosure.

In the specification, reference may be made to the spatial relationships between various components and to the spatial orientation of various aspects of components as the devices are depicted in the attached drawings. However, as will be recognized by those skilled in the art after a complete reading of the present disclosure, the devices, members, apparatuses, *etc.* described herein may be positioned in any desired orientation. Thus, the use of terms such as "above," "below," "upper," "lower," or other like terms to describe a spatial relationship between various components or to describe the spatial orientation of aspects of such components should be understood to describe a relative relationship between the components or a spatial orientation of aspects of such components, respectively, as the device described herein may be oriented in any desired direction.

Referring now to Figure 1 in the drawings, a rotorcraft 101 is illustrated. Rotorcraft 101 has a rotor system 103 with a plurality of rotor blades 205. The pitch of each rotor blade 205 can be manipulated in order to selectively control direction, thrust, and lift of rotorcraft 101. Rotorcraft 101 can further include a fuselage 107, anti-torque system 109, and an empennage 111. A variety of members on rotorcraft 101 can be manufacturing as a core (honeycomb, foam, or honeycomb/foam) stiffened structure, as discussed further herein.

Referring now also to Figures 2 and 3, rotor blade 205 is an example of a rotorcraft member than can be configured with core to efficiently provide strength and stiffness. Rotor blade 205 can include a leading edge portion 207, a trailing edge portion 209, a root end portion 203, and a tip end portion 204. In the illustrated embodiment, an upper skin 211 and a lower skin 213 form an aerodynamic surface with a spar member 215 and a core member 217 forming the internal structure.

It should be appreciated that rotorcraft 101 is merely illustrative of an aircraft for with which one or more methods of the present disclosure can be utilized with regard to. Further, rotor blade 205 is merely illustrative of the wide variety of core stiffened structures that can utilize one or methods disclosed herein. In another embodiment, a horizontal stabilizer 115 is the core stiffened structure, for example.

Referring now to Figure 4, a method 401 of repairing a honeycomb core stiffened structure is schematically illustrated. During operation of rotorcraft 101, damage to a core stiffened structure can occur in a variety of scenarios, such as a collision with an object. In order to ensure safety of the rotorcraft, the damaged portion of the core stiffened structure must be repaired. It should be appreciated that the damage can exist in the skin and/or the honeycomb core. However, removal of the damaged skin may also require repair of the honeycomb core since the skin and the honeycomb core are bonded together. For illustrative purposes, method 401 is illustrated and described herein with regard to repair of rotor blade 205; however, it should be appreciated that method 401 can be performed on any core stiffened structure.

Method 401 can include a step 403 of removing the damaged portion of skin, such as upper skin 211, and the damaged portion of honeycomb core, such as core member 217. For illustrative purposes, Figure 5 shows the damaged skin portion removed by a cutout, which in the illustrated embodiment is circular. Further, Figure 6 shows the damaged core portion removed, which creates a cavity 219. Removal of the damaged skin portion and the damaged core portion can be performed with a circular saw, for example.

Method 401 can further include a step 405 for cleaning and removing any contaminants in and around cavity 219. Step 405 can include using a cleaning solution, such as an alcohol based fluid to remove contaminants.

Method 401 can include a step 407 for mixing and preparing a foam mixture. Referring now also to Figures 8-10, the foam system used in method 401 is preferably a pourable urethane foam system that expands to fill cavity 219 of core member 217. Upon curing, the foam is preferably rigid and flexible, while having a relatively low density, or a density similar to the core. In the illustrated embodiment, the foam system is a polyisocyanurate pour foam system marketed under the name of Stepanfoam BX 450, by the Stepan Chemical Company. It should be fully appreciated that other foam systems may be used. The Stepanfoam BX 450 includes two separate resin components, namely a resin T (70% by weight) 805 and a resin R (30% by weight) 803. The desired weight amounts of resin T 805 and resin R 803 are measured and poured into a container 801. The resin T 805 and resin R 803 are mechanically agitated to form a homogenous mixture 807. A mixer 901 can be used in rotation in order to mix resin T 805 and resin R 803 to form mixture 807. Mixer 901 includes a shaft 903, the shaft 903 being configured to be driven by a drill motor, or the like.

Mixer 901 may include a plurality of blades located on a first blade disc 905 and a second blade disc 907. In the illustrated embodiment, mixer 901 is rotated at 3500 revolutions per minute for 10-15 seconds when mixing resin T 805 and resin R 803 to form mixture 807.

A step 409 includes pouring foam mixture 807 into cavity 219. Once the mixing in step 409 is complete, it is preferred that mixture 807 is poured into cavity 219 as quickly as possible. Once foam mixture 807 is poured into cavity 219, foam mixture 807 is allowed to expand and fill the space of cavity 219 so as to form an expanded foam 221 (shown in Figure 7). In the illustrated embodiment, the foam mixture 807 is allowed to "free rise"; however, an alternative embodiment can include restricting the expansion by placing an upper mold over the cavity 219. Preferably, the upper mold would include an opening that allows the release of outgases.

A step 411 includes trimming the expanded foam 221 after foam mixture 807 has fully expanded and become semi-rigid. Trimming the expanded foam 221 includes reducing the outer surface to correspond approximately with the outer airfoil surface of upper skin 211. Step 411 can be performed by any variety of processes, such as a cutting, sanding, machining, to name a few examples. Figure 11A is an illustration of expanded foam 221 trimmed such that the outer surface corresponds approximately to the outer airfoil surface of upper skin 211.

A step 413 includes laying up a composite skin patch 223 on the expanded foam 221 and allowing the repair assembly to cure. An illustrative composite skin patch 223 is shown in Figure 11B. In the illustrated embodiment, composite skin patch 223 is a plurality of strips of composite fibers with resin (i.e. pre-preg). Composite skin patch 223 can be laid directly onto the outer surface of expanded foam 221. Composite skin patch 223 and expanded foam 221 are allowed to cure. In the illustrated embodiment, the curing of composite skin patch 223 and expanded foam 221 takes place at room temperature, such that an artificial heat source is not required. In another embodiment, skin patch 223 can be a precured composite skin patch or of another rigid material, such as a metal skin patch. In such an embodiment, the rigid skin patch can be adhesively bonded to the expanded foam 221 with an adhesive.

Method 401, as described further herein, includes significant advantages of conventional repair methods. For example, method 401 does not require special repair tooling that would

otherwise be required to separately lay-up and cure a composite patch. Further, method 401 does not require thermal equipment that would be required if an adhesive as used that required an elevated temperature to cure. Further, method 401 can be performed in the field such that repairs to composite core stiffened structures do not have to be performed in a facility having specialized equipment. Further, when method 401 is performed on composite core stiffened structure wherein the composite core is large cell core (cells greater than 0.5 inches), the expanded foam 221 (as trimmed) acts as a tooled surface so as to provide uniform support of the composite skin patch 223 prior and during curing.

It should be appreciated that method 401 can be performed on a wide variety of core-stiffened structures. Further, the core-stiffened structures can have a core member 217 comprising any variety of materials, such as carbon, paper, Nomex®, fiberglass, Kevlar®, plastic, metal, foam, to name a few examples. Further, core member 217 can have cell members of a variety of shapes, such as square, hexagonal, elliptical, round, to name a few examples. Further, core member 217 may not even have cell members, particularly when core member 217 is a foam material.

Referring now to Figure 12, a method 1201 of splicing together one or more sections of core material is schematically illustrated. During fabrication of a core stiffened structure, such as rotor blade 205, it can be necessary to splice one or more sections of core material together. However, conventional methods of splicing core material have significant deficiencies, as described further herein.

Referring also to Figure 13, method 1201 can include a step 1203 of positioning a first core member 1301 adjacent to a second core member 1303. Step 1203 can be implemented in a variety of environments. For example, tooling can be used for aligning first core member 1301 adjacent to second core member 1303; however, tooling is not necessarily required. One advantage of using foam for splicing first core member 1301 to second core member 1303 is the increase in bonding surface reduces the importance of bond surface alignment that can exist in a conventional adhesive bonding procedure.

Step 1205 includes preparing and mixing the foam mixture, which is similar to step 407 described herein with regard to method 401. Method 1201 also includes a step 1207 for pouring the foam mixture into the splicing area common to the cell walls of first core member 1301 and second core member 1303. In another embodiment, step 1207 is accomplished

by pouring the foam mixture into a cavity below splicing area so that the foam mixture expands and rises into the splicing area, similar to as described with regard to Figure 33. Such a technique may be particularly desirable when the cells are relatively small and/or the cell walls lack porosity. The foam mixture is allowed to expand into an expanded foam. A step 1209 includes curing the expanded foam. In the illustrated embodiment, the expanded foam can be cured at room temperature in a relatively short amount of time. One advantage of method 1201 is that the process does not require thermal equipment that may otherwise be required to cure a conventional adhesive. A step 1211 can include trimming the expanded foam to be flush with the upper and lower surfaces of first core member 1301 and second core member 1303. Step 1211 can also include machining the first core member 1301 and the second core member 1303 to a desired contour while also trimming the expanded foam.

Referring now also to Figures 14-16, example embodiments of core members spliced together using method 1201 are illustrated. Referring in particular to Figure 14, first core member 1301 and second core member 1303 are both honeycomb composite core members of the same size and material. Expanded foam 1305 is in bonding contact with the adjacent cell walls of first core member 1301 and second core member 1303. Referring in particular to Figure 15, first core member 1301 and second core member 1303 are in bonding contact with expanded foam 1305. In the illustrated embodiment, second core member 1303 has smaller sized cell members compared to first core member 1301. The illustrated embodiment is meant to demonstrate how the expanded foam 1205 is particularly advantageous for splicing together core members having different geometry and/or cell sizes. As illustrated, expanded foam 1205 provides bonding contact with the cell walls of first core member 1301 and second core member 1303 even though the geometry of the cell walls don't provide symmetric bonding surfaces. Further, the splicing of two different core members, each having different geometries, can be particularly useful when tailoring stiffness across a structure. For example, rotor blade 205 can have spliced core members such that the larger core member is located more towards spar member 215 while the smaller core member is located towards the trailing edge 209. It should be appreciated that method 1201 can be employed to splice any number of core members together, the core members having any variety of cell sizes and geometries.

Referring in particular to Figure 16, first core member 1301 and second core member 1303 are in bonding contact with expanded foam 1305. In the illustrated embodiment, second

core member 1303 is a foam core that does not have honeycomb shaped cell members. Second core member 1303 can be any type of foam of supporting structure having a homogenous material continuity. For example, second core member can be of a polyvinyl chloride (PVC) type material. Method 1201 is particularly well suited for splicing a traditional honeycomb core member to a solid core since the expanded foam 1305 adheres well to both members, unlike traditional splicing adhesives.

Referring now to Figure 17, a method 1701 of joining together a core material to a structure is schematically illustrated. During fabrication of a core stiffened structure, such as rotor blade 205, it can be desirable to abutly join a core member, such as core 217, to a structure, such as spar 215 (shown in Figure 3). However, conventional methods of joining core material to structure have significant deficiencies, as described further herein.

Referring also to Figure 18, method 1701 can include a step 1703 of positioning a core member 1801 adjacent to a structure 1803. Step 1703 can be implemented in a variety of environments. For example, tooling can be used for aligning core member 1801 adjacent to structure 1803; however, tooling is not necessarily required. One advantage of using foam for joining core member 1801 to structure 1803 is the increase in bonding surface prevents the meticulous adhesive application along mating portions of core member 1801 to structure 1803, which may otherwise be required in a conventional process.

Step 1705 includes preparing and mixing the foam mixture, which is similar to step 407 described herein with regard to method 401. Method 1701 also includes a step 1707 for pouring the foam mixture into the joining area common to the exposed cell walls of core member 1801 and the exposed surface of structure 1803. In another embodiment, step 1707 is accomplished by pouring the foam mixture into a cavity below joining area so that the foam mixture expands and rises into the joining area, similar to as further described with regard to Figure 33. Such a technique may be particularly desirable when the joining area is relatively small and the cell walls lack porosity. The foam mixture is allowed to expand into an expanded foam 1805. A step 1709 includes curing expanded foam 1805. In the illustrated embodiment, the expanded foam 1805 can be cured at room temperature in a relatively short amount time. One advantage of method 1701 is that the process does not require thermal equipment that may otherwise be required to cure a conventional adhesive. A step 1711 can include trimming the expanded foam 1805 to be flush with the upper and lower surfaces of core member 1801 and structure 1803.

Referring now to Figure 19, a method 1901 of machining honeycomb core is schematically illustrated. During fabrication of a core stiffened structure, such as rotor blade 205, it is necessary to machine the honeycomb core member, such as core 217 (shown in Figure 3), to a desired contour. However, conventional methods of machining core material have significant deficiencies, as described further herein.

Referring also to Figures 20 and 21, method 1901 can include a step 1903 of preparing and mixing the foam mixture, which is similar to step 407 described herein with regard to method 401. Method 1901 also includes a step 1905 of pouring the foam mixture into the cells of a stock core member 2001. In another embodiment, step 1907 is accomplished by pouring the foam mixture into a cavity below the cells so that the foam mixture expands and rises into the cells, similar to as further described with regard to Figure 33. Such a technique may be particularly desirable when the cell are relatively small and/or the cell walls lack porosity. The foam mixture is allowed to expand into an expanded foam 2003. A step 1907 includes curing expanded foam 2003. In the illustrated embodiment, the expanded foam 2003 can be cured at room temperature.

Method 1901 includes a step 1909 of machining the stock core member 2001 containing expanded foam 2003 to a desired contour. A contouring machine 2005 can be used to controllably machine away undesired portions of stock core member 2001 containing expanded foam 2003 until the desired contour is achieved. Referring to Figure 21, a final foam filled core member 2007 is illustrated. Using expanded foam 2003 to support the honeycomb core during machining not only increases the speed at which the honeycomb core can be machined, but also allows the honeycomb core to be machined at more severe angles, smaller thicknesses, and complex contours. Further, expanded foam 2003 adds strength and stiffness to stock core member 2001.

Referring now to Figures 22-24, a core stiffened structure 2201 that is manufactured utilizing one or more methods described herein is illustrated. Structure 2201 can be any of a variety of structural members. For example, structure 2201 can be a panel 113 on rotorcraft 101, as illustrated in Figure 1. Structure 2201 can have an upper skin 2203, a lower skin 2205, and a honeycomb core 2207 filled with an expanded foam 2209. Honeycomb core 2207 can be filled with expanded foam 2209 and machined with method 1901, as described further herein.

Structure 2201 is illustrative of one unique advantage of utilizing honeycomb core 2207 filled with expanded foam 2209. Not only can the honeycomb core be machined faster and more accurately when filled with expanded foam, but structure 2201 can be manufactured so that the structure itself is more efficient. Unlike traditional composite core structures, the end portions of honeycomb 2207 can be vertical since the expanded foam 2209 provides the necessary strength to withstand autoclave pressure during the curing of structure 2201. In the illustrated embodiment, the end portion or ramp angle A1 is 90°; however, alternative embodiments can have a ramp angle A1 that is less than 90°. For example, ramp angle A1 can be 75°. Conventional composite core structures are restricted to a ramp angle less than 27° so that the honeycomb core does not crush during the autoclave pressure of the curing cycle.

Referring now to Figures 25 and 26, a core stiffened structure 2501 that is manufactured utilizing one or more methods described herein is illustrated. Structure 2501 can have any of a variety of structural implementations. For example, structure 2501 can be a floor panel within fuselage 107 on rotorcraft 101, as illustrated in Figure 1. Structure 2501 can have an upper skin 2503, a lower skin 2505, and a honeycomb core 2507 filled with an expanded foam 2509. Honeycomb core 2507 can be filled with expanded foam 2509 and machined with method 1901, as described further herein.

Structure 2501 is illustrative of one unique advantage of utilizing honeycomb core 2507 filled with expanded foam 2509. Not only can the honeycomb core 2507 be machined faster and more accurately when filled with expanded foam 2509, but structure 2501 can be utilized to support out-of-plane loads with an attachment assembly, such as sleeve assembly 2511, without having to use a heavy potting compound since the expanded foam 2509 provides the necessary strength to support the loading around the sleeve assembly 2511. In the illustrated embodiment, the attachment assembly is illustrated as sleeve assembly 2511; however, it should be appreciated that the attachment assembly can be any of a variety of attachment members configured for coupling to an apparatus. For example, sleeve assembly 2511 is particularly well suited as a mounting apparatus for an occupant seat on the floor member 2501 of rotorcraft 101. Sleeve assembly 2511 can have an upper sleeve 2513 and a lower sleeve 2515 that matingly fit together. In one embodiment, sleeve assembly 2511 has internal threads that are configured for receiving a seat attachment fitting.

Referring in particular to Figure 26, structure 2601 is substantially similar to structure 2501 except that expanded foam 2509 does not completely fill honeycomb core 2507, but rather expanded foam 2509 is particularly located in regions where each sleeve assembly 2511 is to be installed. A large floor panel structure can have any plurality of regions of expanded foam 2509 so that a desired seating configuration can be mounted to the structure with the implementation specific attachment assembly.

Referring now to Figure 27, a core stiffened structure 2701 that is manufactured utilizing one or more methods described herein is illustrated. Structure 2701 can have any of a variety of structural implementations. For example, structure 2701 can be a horizontal stabilizer 115 on rotorcraft 101, as illustrated in Figure 1. Structure 2701 can have an upper skin 2703, a lower skin 2705, an inner support 2707, an upper core member 2709, a lower core member 2711, a forward foam member 2713, and an aft foam member 2715. In the illustrated embodiment, upper core member 2709 and lower core member 2711 are not filled with foam, but in an alternative embodiment upper core member 2709 and a lower core member 2711 are filled with expanded foam, such as expanded foam 2509, illustrated in Figure 25 and further described herein. In another embodiment, only upper core member 2709 is filled with foam in order to provide increased strength and stiffness to withstand heat induced stressed near the upper surface, the heat being discussed further below.

Core stiffened structure 2701 utilizes forward foam member 2713 for structurally joining forward edges of upper core member 2709 and lower core member 2711 together with upper skin 2703, lower skin 2705, and inner support 2707. Similarly, aft foam member 2715 structurally joins aft edges of upper core member 2709 and lower core member 2711 together with upper skin 2703, lower skin 2705, and inner support 2707. The filling and adhesion qualities make expandable foam uniquely capable of joining honeycomb core members that are out-of-plane to each other. In other words, expandable foam can be used to join honeycomb core members that are not adjacent to each other in the same plane.

In the illustrated embodiment, core stiffened structure 2701 can be manufactured by assembling the components, then subsequently filling the respective cavities to form forward foam member 2713 and aft foam member 2715 with foam. Forward foam member 2713 and aft foam member 2715 can be formed by mixing pourable foam as described in step 407 of method 401, and then pouring the foam into the cavities as similarly described in step 409 of

method 401. The expanded foam can be trimmed and cured, as also further described herein.

In the illustrated embodiment, core stiffened structure 2701 is a horizontal stabilizer which can be subjected to heat from the exhaust system. The dynamic heat flow typically subjects the upper surface of the structure 2701 to the most severe heat. In order to withstand, upper skin 2703 is formed from a composite system having a high temperature resistance resin, such as Bismaleimide (BMI) resin. However, BMI resin is typically expensive and expensive to use. As such, the unique configuration of core stiffened structure 2701 inhibits heat transfer from upper skin 2703 to lower skin 2705 because the honeycomb core does not extend from the upper surface to the lower surface, rather inner support 2707 separates the honeycomb core between upper core member 2709 and lower core member 2711, thereby acting as an insulator. Further, forward foam member 2713 and aft foam member 2715 structural join upper core member 2709 and lower core member 2711 while also inhibiting heat transfer therebetween. Such a configuration allows lower skin 2705 to be manufactured out of a composite system having a typical non-high temperature resin, thereby saving the expense associated with using BMI resin.

It should be appreciated that even though internal member 2707 is illustrated as an enclosed member, the geometry of internal member 2707 is implementation specific. For example, an alternative embodiment of internal member 2707 can be C-shaped, I-shaped, or even be multiple single surface members, to name a few examples.

Referring now to Figure 28, a core stiffened structure 2801 that is manufactured utilizing one or more methods described herein is illustrated. Structure 2801 can have any of a variety of structural implementations. For example, structure 2801 can be a tailboom member on a rotorcraft. Structure 2801 can have an outer skin 2803, an inner skin 2805, a core member 2807, and a foam member 2811. In the illustrated embodiment, core member 2807 is filled with expanded foam 2809; however, in an alternative embodiment core member 2807 is void of expanded foam 2809. Expanded foam 2809 inhibits heat transfer from outer skin 2803 to inner skin 2805, as discussed further below.

Core stiffened structure 2801 utilizes foam member 2811 for structurally joining edges of core member 2807. The filling and adhesion qualities make expandable foam uniquely capable of joining honeycomb core members that are out-of-plane to each other. In other

words, expandable foam can be used to join honeycomb core members that are not adjacent to each other in the same plane.

In the illustrated embodiment, core stiffened structure 2801 can be manufactured by assembling the components, then subsequently filling the respective cavity with foam to form foam member 2811. Foam member 2811 can be formed by mixing pourable foam as described in step 407 of method 401, and then pouring the foam into the cavity as similarly described in step 409 of method 401. The expanded foam can be trimmed and cured, as also further described herein. Core member 2807 can be formed by method 1901, for example.

In the illustrated embodiment, core stiffened structure 2801 is a tailboom member which can be subjected to heat from the exhaust system of the rotorcraft. The heat flow typically subjects the upper surface of the structure 2801 to the most severe heat. In order to withstand, an upper portion of outer skin 2803 is formed from a composite system having a high temperature resistance resin, such as Bismaleimide (BMI) resin. However, BMI resin is typically expensive and expensive to use. As such, the unique configuration of core stiffened structure 2801 inhibits heat transfer from outer skin 2803 to inner skin 2805 because the expanded foam 2809 inhibits heat flow through honeycomb core 2807, thereby acting as an insulator. Such a configuration also allows the remaining portion of outer skin 2803 and the inner skin 2805 to be manufactured out of a composite system having a typical non-high temperature resin, thereby saving the expense associated with using BMI resin.

Referring now to Figure 29, a method 2901 of stabilizing honeycomb core during an autoclave cure of a core stiffened panel is schematically illustrated. Conventionally, honeycomb core is required to have low angle beveled edge portions to prevent a crushing of the honeycomb core due autoclave pressure in the curing cycle. Conventionally, if the geometry of the core stiffened panel did not allow for the low angle bevel, then the core stiffened panel would have to be manufacturing using labor intensive and procedures (multiple cure cycles) that can also add significant weight penalties. In contrast, method 2901 of the present disclosure prevents the autoclave crushing of honeycomb core at any core bevel angle, while allowing the core stiffened structure to be cured in a single cure cycle.

Method 2901 includes a step 2903 of mixing and preparing the foam mixture. Step 2903 is substantially similar to step 407 described herein with regard to method 401. A step 2905 includes expanding the foam mixture in the desired honey comb cells. Step 2907 includes trimming the expanded foam. A step 2909 includes assembling the composite skins with the honeycomb core member and curing in a cure cycle.

Referring now also to Figures 30-34, method 2901 is further described with regard to the manufacturing of core stiffened panel 3001. Core stiffened panel 3001 is illustrative of any variety of composite structures. For example, core stiffened panel 3001 can be a floor panel within fuselage 107 of rotorcraft 101. Core stiffened panel 3001 can include an upper composite skin 3003, a lower composite skin 3005, and a honeycomb core member 3007. The edge bevel portions 3011 of honeycomb core member 3007 are filled with expanded foam 3009 in order to provide the strength and stiffness to prevent deformation during the autoclave cure cycle. Edge bevel portions 3011 can be of any bevel angle B1 and are not limited to a bevel angle less than 27°. In the illustrated embodiment, bevel angle B1 is approximately 60°.

Step 2905 of method 2901 includes expanding the foam mixture in the desired honeycomb cells. Referring in particular to Figure 33, step 2905 can be accomplished by pouring the foam mixture into a cavity tool 3301, then placing the stock honeycomb core on the cavity tool 3301 so that the foam mixture expands and fills the desired honeycomb cells that will be trimmed to the form the edge bevel portions 3011. In another embodiment, the foam mixture is poured into the cells. It should be appreciated that the edge bevel portions 3011 can be machined into the stock honeycomb core either before or after the foam mixture is expanded into the cells.

Step 2905 can also include tailoring the density of the expanded foam 3009 within honeycomb core member 3007. For example, the density of the expanded foam tends to decrease as a function of vertical height, as such, the height H1 of cavity tool 3301 can be chosen such that the density of the expanded foam 3009 within honeycomb core member 3007 is within a desired density range. By tailoring the density of expanded foam 3009, the strength and stiffness can be tailoring based upon a variety of factors, such as autoclave pressure, edge bevel angle B1, honeycomb core material, to name a few. For example, it may be desirable to use a higher density of expanded foam where the edge bevel angle B1 is larger than an area where the edge bevel angle B1 is smaller.

Step 2907 can include trimming the expanded foam 3009. Referring to Figure 34, a fully trimmed honeycomb core member 3007 is illustrated. In the illustrated embodiment, the expanded foam 3009 is trimmed when the edge bevel portions 3011 are machined into the stock honeycomb core.

A step 2909 includes assembling the composite skins with the honeycomb core member and curing in a cure cycle. In the illustrated embodiment, upper skin 3003 and lower skin 3005 are cured after assembly in a single cure cycle involving autoclave pressure and heat.

The particular embodiments disclosed above are illustrative only, as the apparatuses and methods may be modified and practiced in different but equivalent manners apparent to those skilled in the art having the benefit of the teachings herein. Modifications, additions, or omissions may be made to the apparatuses described herein without departing from the scope of the invention. The components of the system may be integrated or separated. Moreover, the operations of the system may be performed by more, fewer, or other components.

Furthermore, no limitations are intended to the details of construction or design herein shown, other than as described in the claims below. It is therefore evident that the particular embodiments disclosed above may be altered or modified and all such variations are considered within the scope of the application. Accordingly, the protection sought herein is as set forth in the claims below.

Claims

1. A core stiffened structure forming an aerodynamic structure of an aircraft, the structure comprising:

a skin having an airfoil-shaped profile, the skin having a leading edge portion, an upper portion, a lower portion, and a trailing edge portion;

an inner support;

an upper core member having a plurality of cell members that collectively have an upper surface and a lower surface, the upper surface of the plurality of cell members of the upper core member being bonded to an inner surface of the upper portion of the skin, the lower surface of the plurality of cell members of the upper core member being bonded to the inner support;

a lower core member having a plurality of cell members that collectively have an upper surface and a lower surface, the upper surface of the plurality of cell members of the lower core member being bonded to the inner support, the lower surface of the plurality of cell members of the lower core member being bonded to an inner surface of the lower portion of the skin;

a forward foam member bonded to a forward surface of the plurality of cell members of the upper core member, to a forward surface of the plurality of cell members of the lower core member, and to the inner support;

an aft foam member bonded to an aft surface of the plurality of cell members of the upper core member, to an aft surface of the plurality of cell members of the lower core member, and to the inner support;

wherein the forward foam member joins by contact the upper core member and the lower core member.

2. The core stiffened structure according to claim 1, wherein the inner support has an upper member, a lower member, a forward member, and an aft member, the lower surface of the plurality of cell members of the upper core member being bonded to the upper member of the inner support, the upper surface of the plurality of cell members of the lower core member being bonded to the lower member of the inner support, the forward foam member being bonded to the forward member of the inner support, and the aft foam member being bonded to the aft member of the inner support.

3. The core stiffened structure according to claim 2, wherein the upper member, lower member, forward member, and aft member of the inner support collectively form a hollow void therebetween.
4. The core stiffened structure according to claim 2 or 3, wherein the upper member, lower member, forward member, and aft member of the inner support define an enclosed geometric shape.
5. The core stiffened structure according to any one of claims 1 to 4, wherein the core stiffened structure is a rotor blade.
6. The core stiffened structure according to any one of claims 1 to 4, wherein the core stiffened structure is a horizontal stabilizer on a rotorcraft.
7. The core stiffened structure according to any one of claims 1 to 6, wherein the forward foam member and the aft foam member have insulative properties so as to inhibit heat transfer between the upper core member and the lower core member.
8. The core stiffened structure according to any one of claims 1 to 7, wherein the upper portion of the skin includes a heat resistant resin while the lower portion of the skin includes a resin having a lower temperature tolerance.
9. The core stiffened structure according to any one of claims 1 to 8, wherein the plurality of cell members of the upper core member are filled with structural foam.
10. The core stiffened structure according to any one of claims 1 to 9, wherein the plurality of cell members of the lower core member are filled with structural foam.
11. The core stiffened structure according to claim 10, wherein the structural foam in the upper core member inhibits heat transfer.

12. A tailboom of a rotorcraft, the tailboom comprising:

an outer skin having a geometry that forms an enclosed void, the outer skin having an upper arcuate portion that includes a heat resistant resin, the outer skin also having a lower arcuate portion that includes a resin with a lower temperature tolerance compared to the heat resistant resin of the upper arcuate portion;

an inner skin located within the enclosed void of the outer skin, thereby forming a space between the inner skin and the outer skin;

an upper core member located between the upper arcuate portion of the outer skin and the inner skin, the upper core member having a plurality of columnar cell members that collectively have an upper surface network and a lower surface network, the upper surface network of the upper core member being bonded to an inner surface of the outer skin and the lower surface network of the upper core member being bonded to an upper surface of the inner skin; and

a foam member located between the lower arcuate portion of the outer skin and the inner skin, the foam member being bonded to a first surface of the plurality of the columnar cell members and a second surface of the columnar cell members.

13. The tailboom according claim 12, wherein the plurality of columnar cell members of the upper core member are filled with a structural foam.

1 / 18

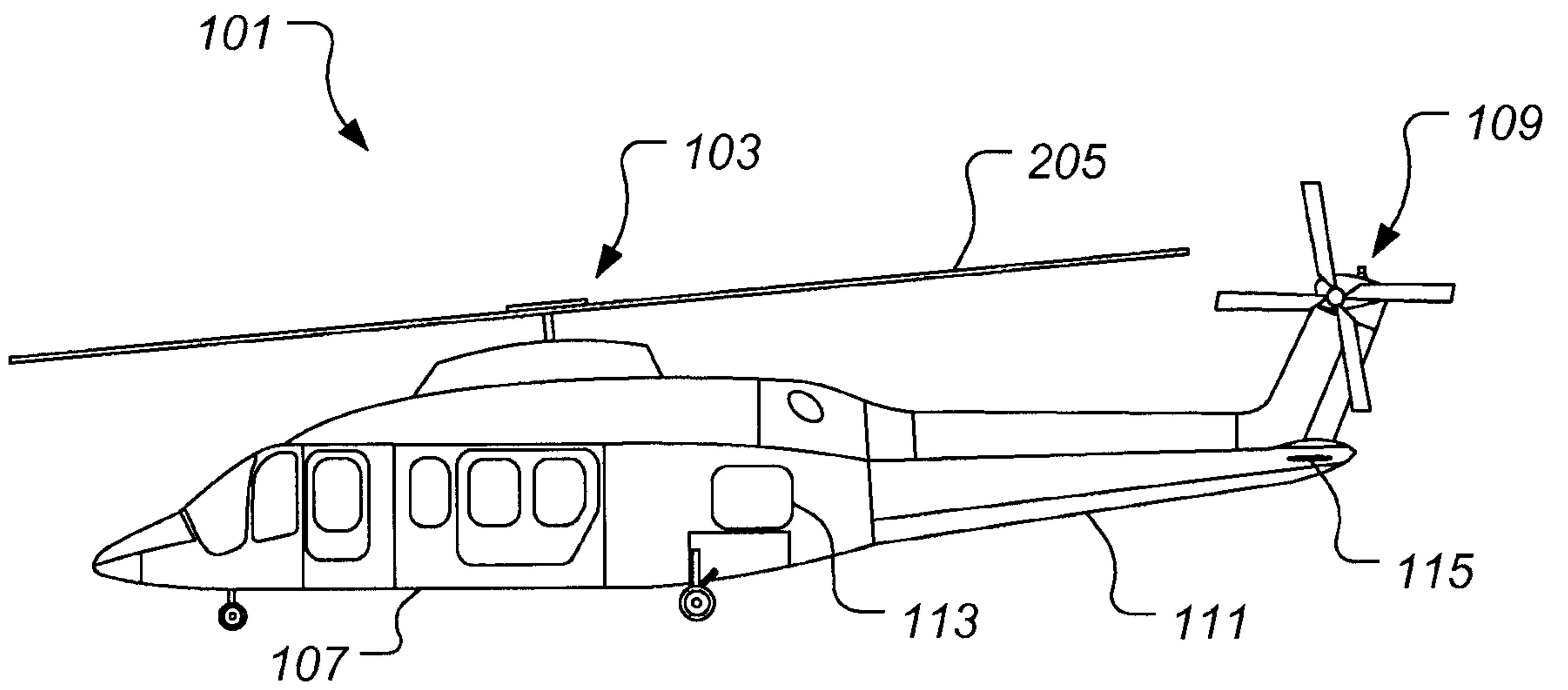

FIG. 1

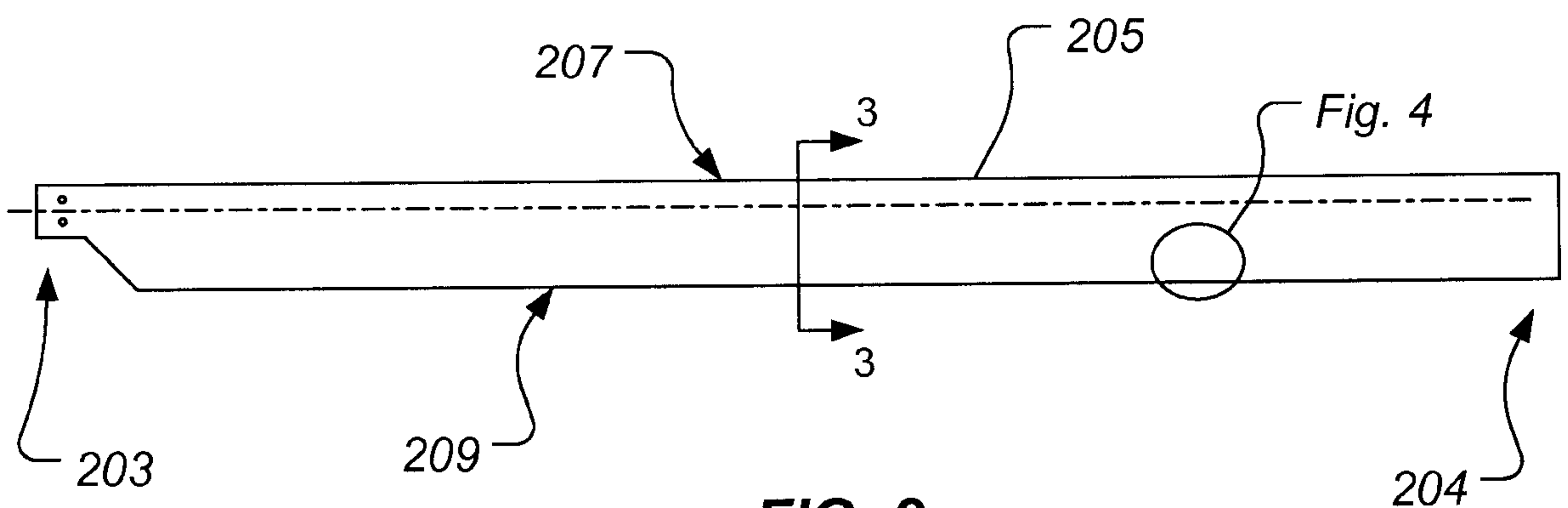

FIG. 2

2 / 18

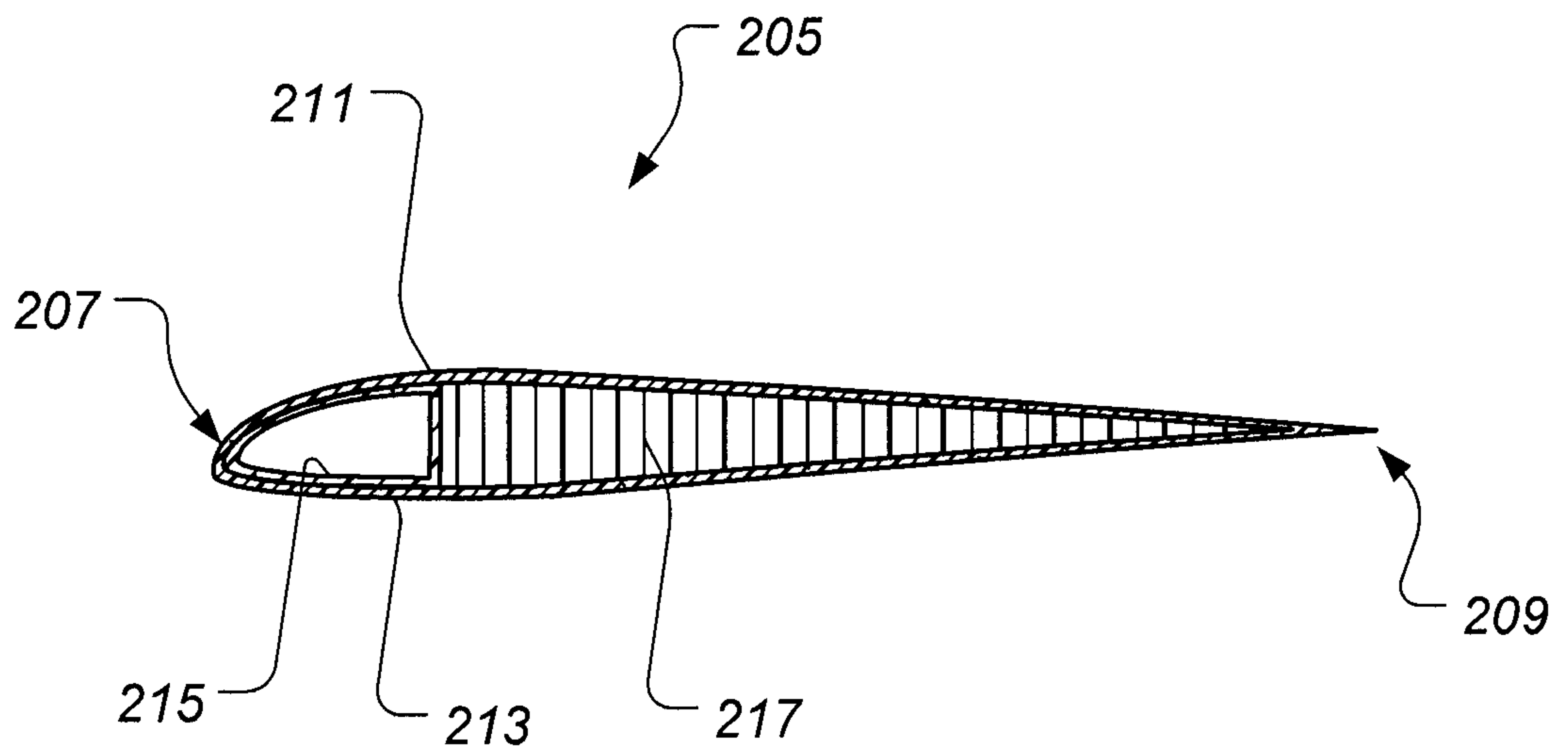

FIG. 3

3 / 18

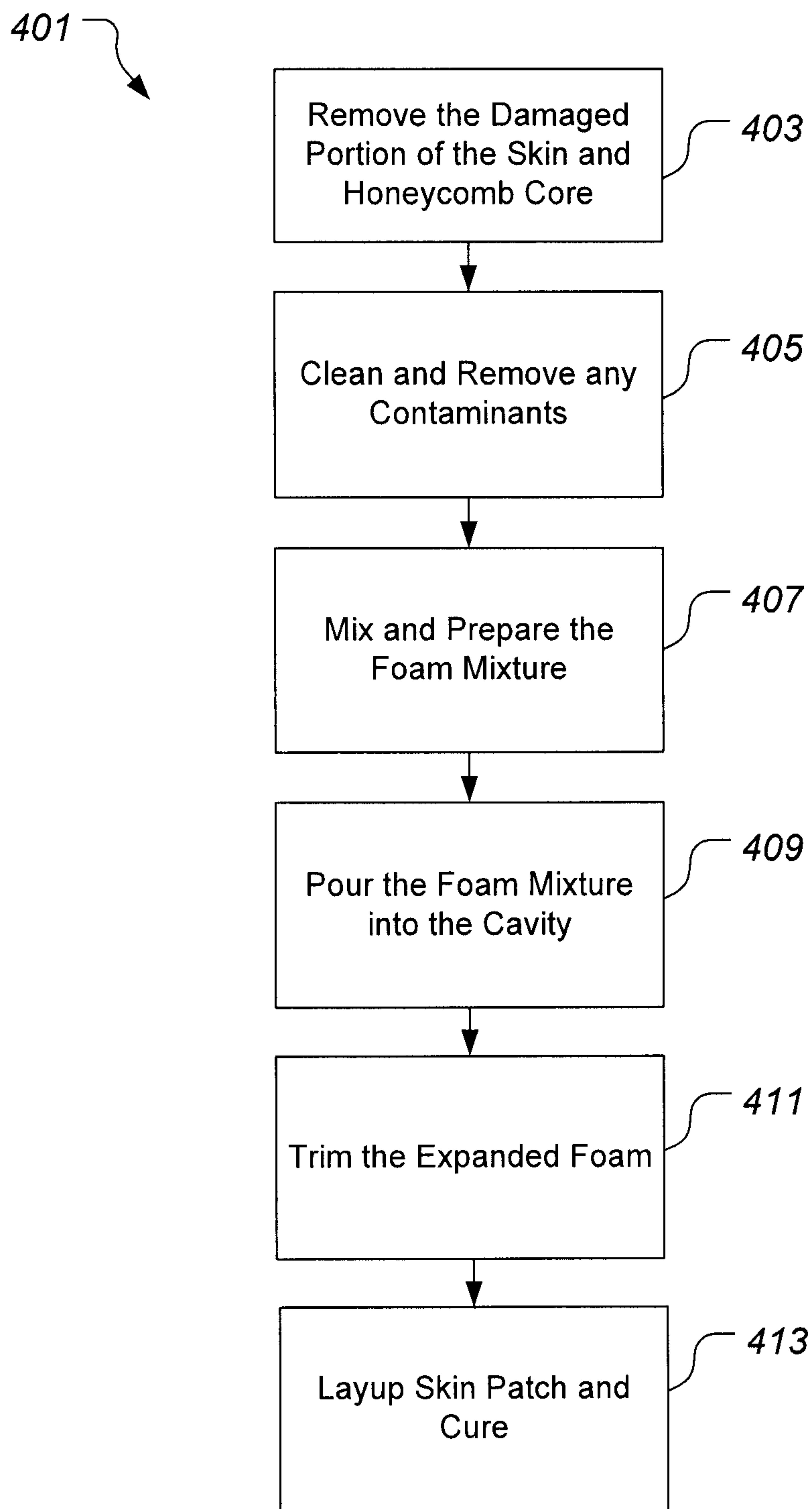

FIG. 4

4 / 18

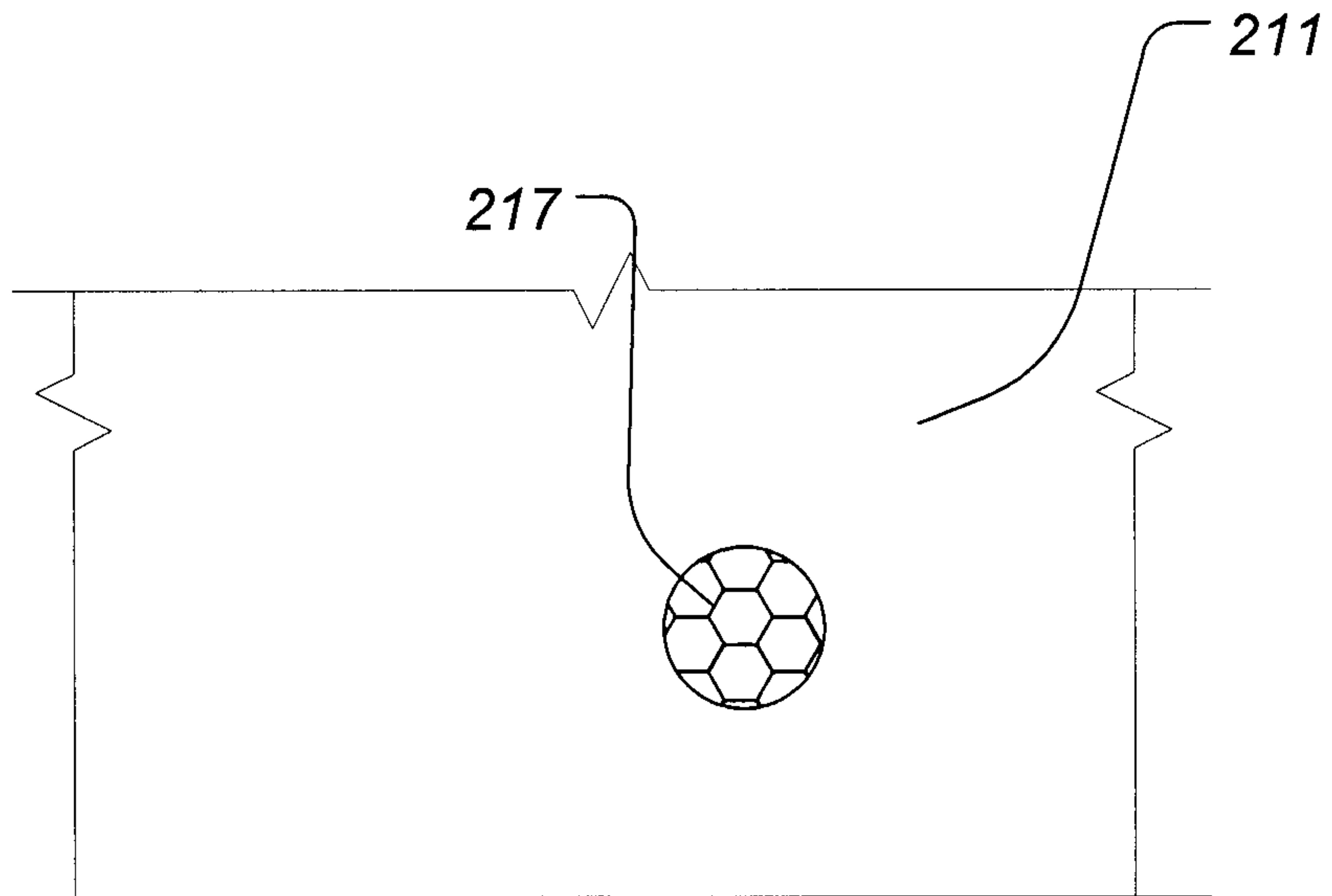

FIG. 5

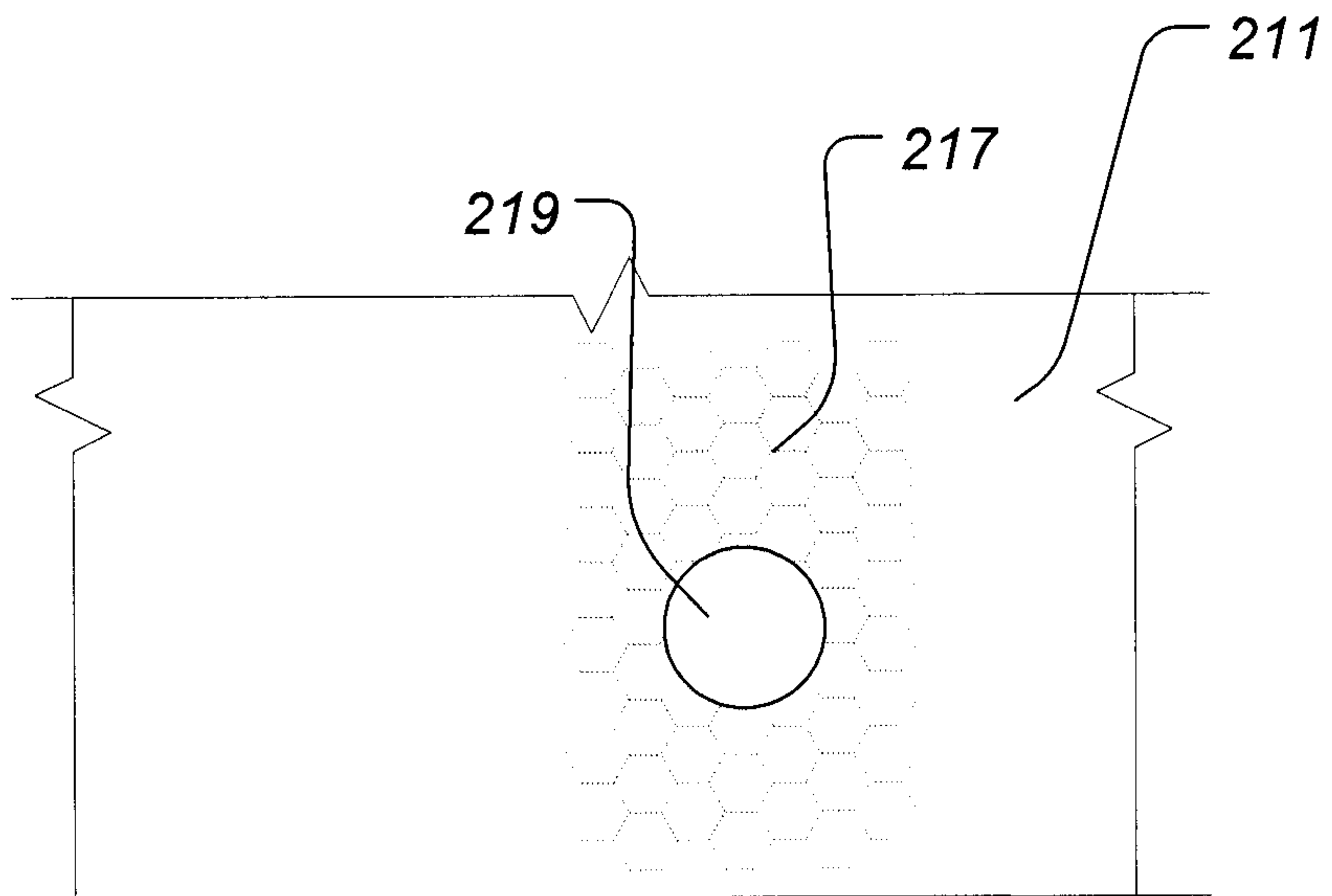

FIG. 6

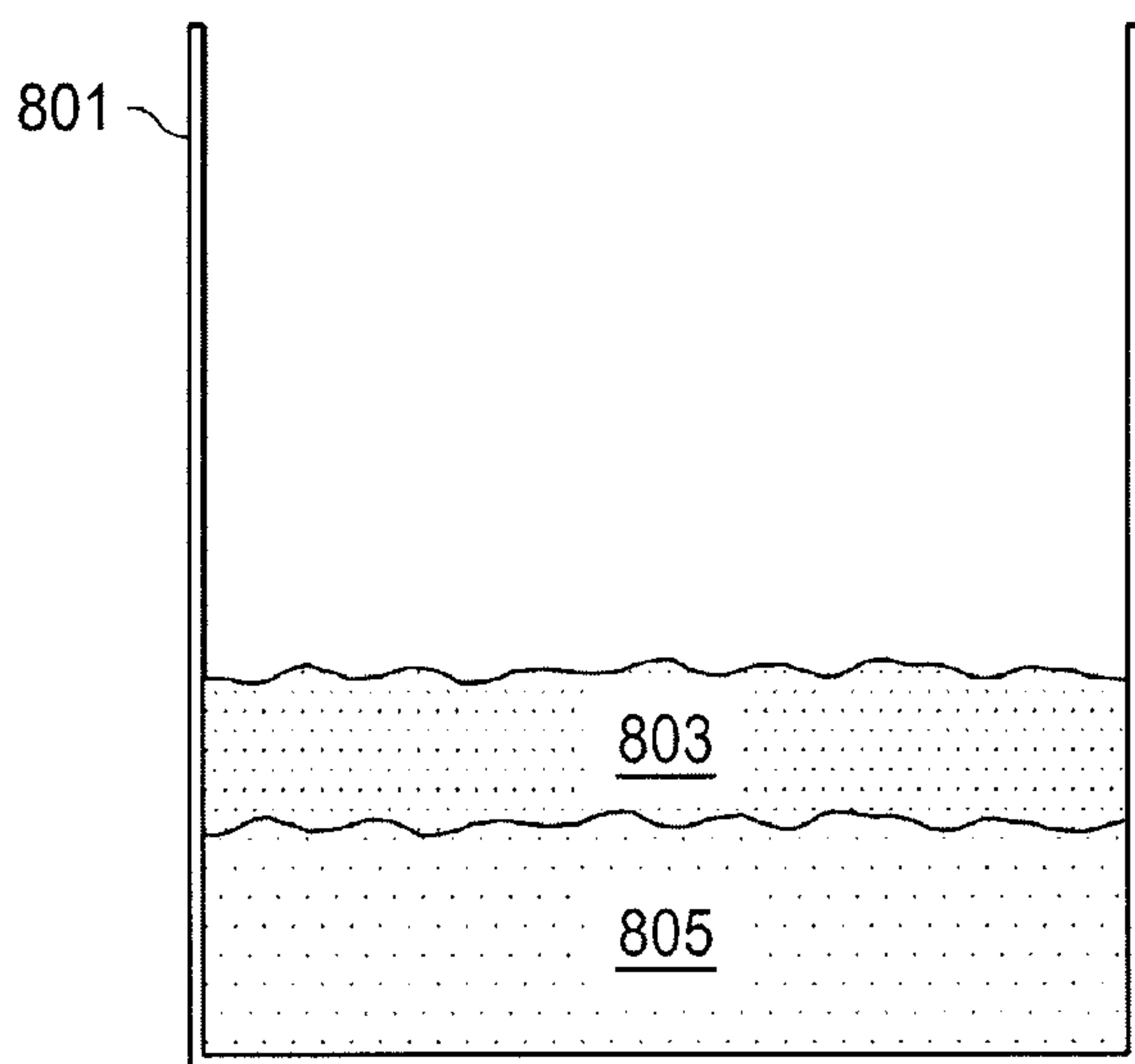

FIG. 8

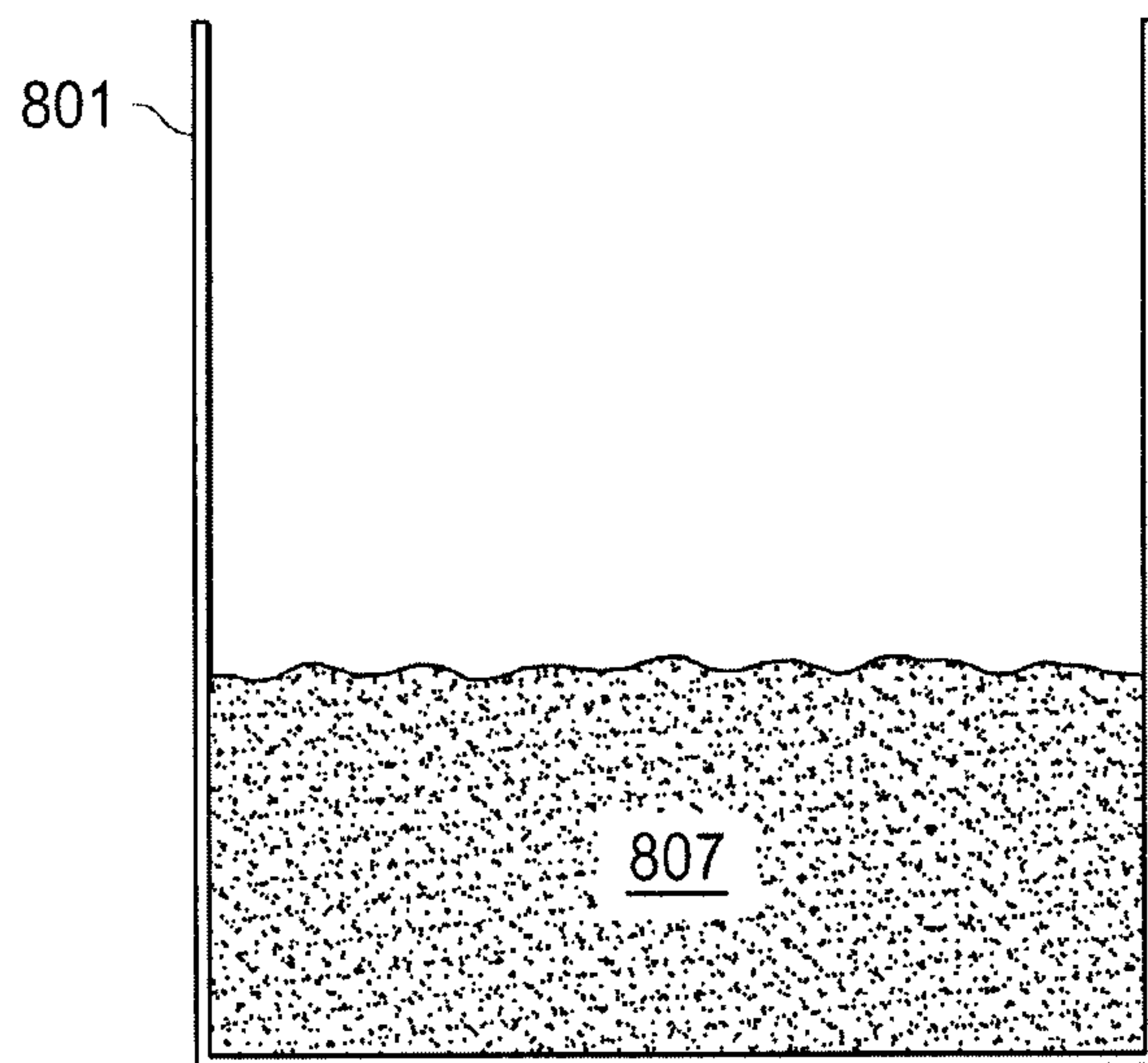

FIG. 10

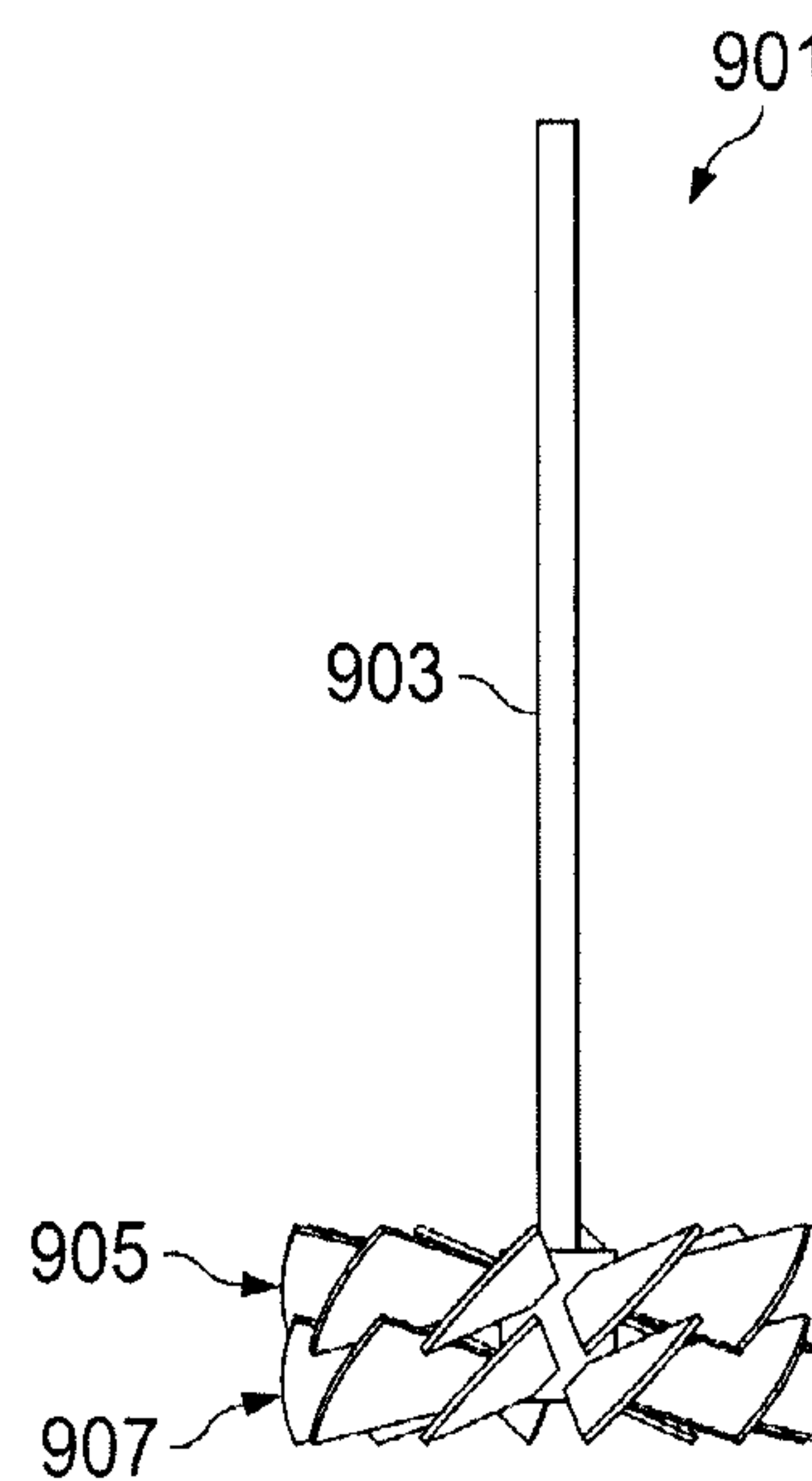

FIG. 9

6 / 18

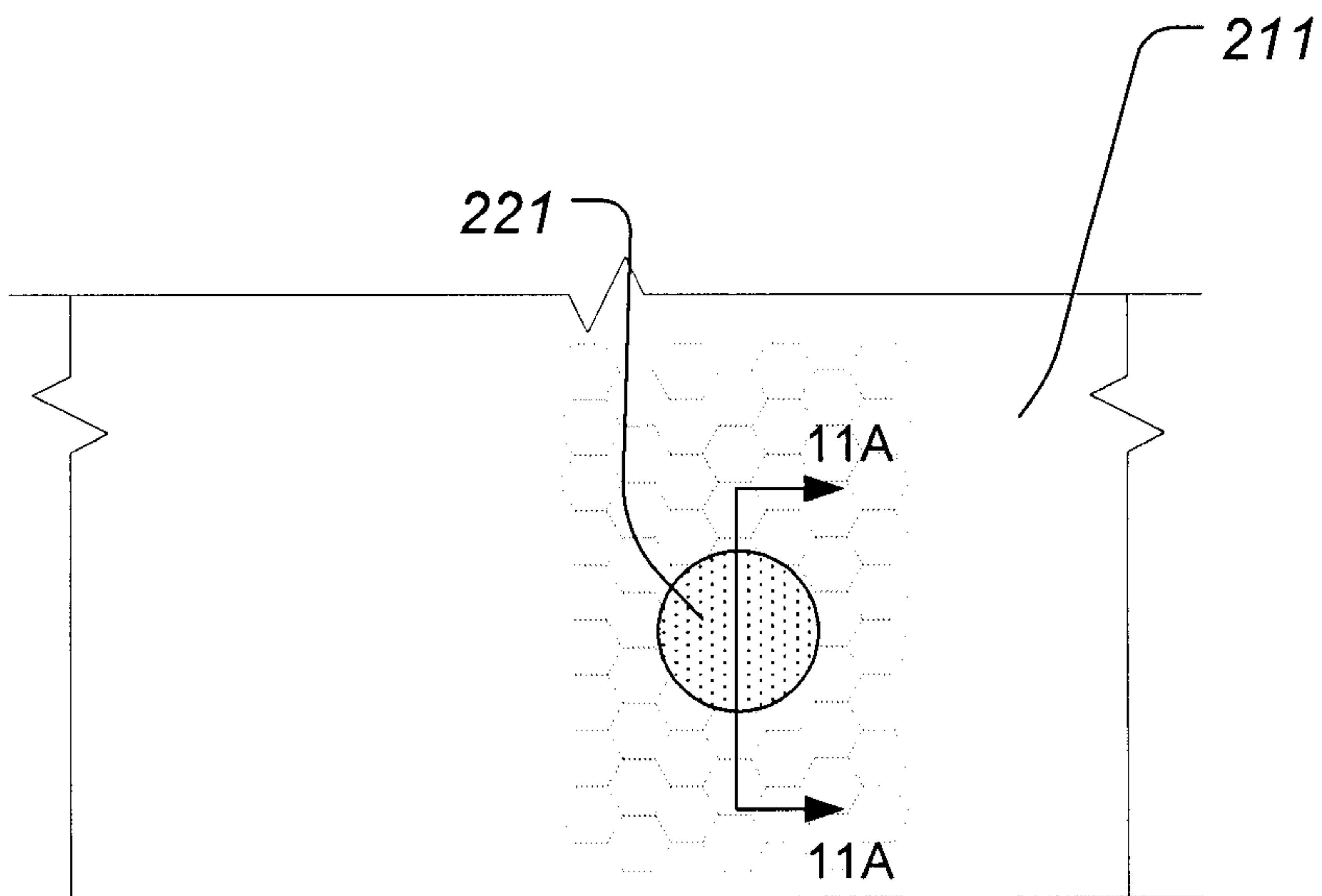

FIG. 7

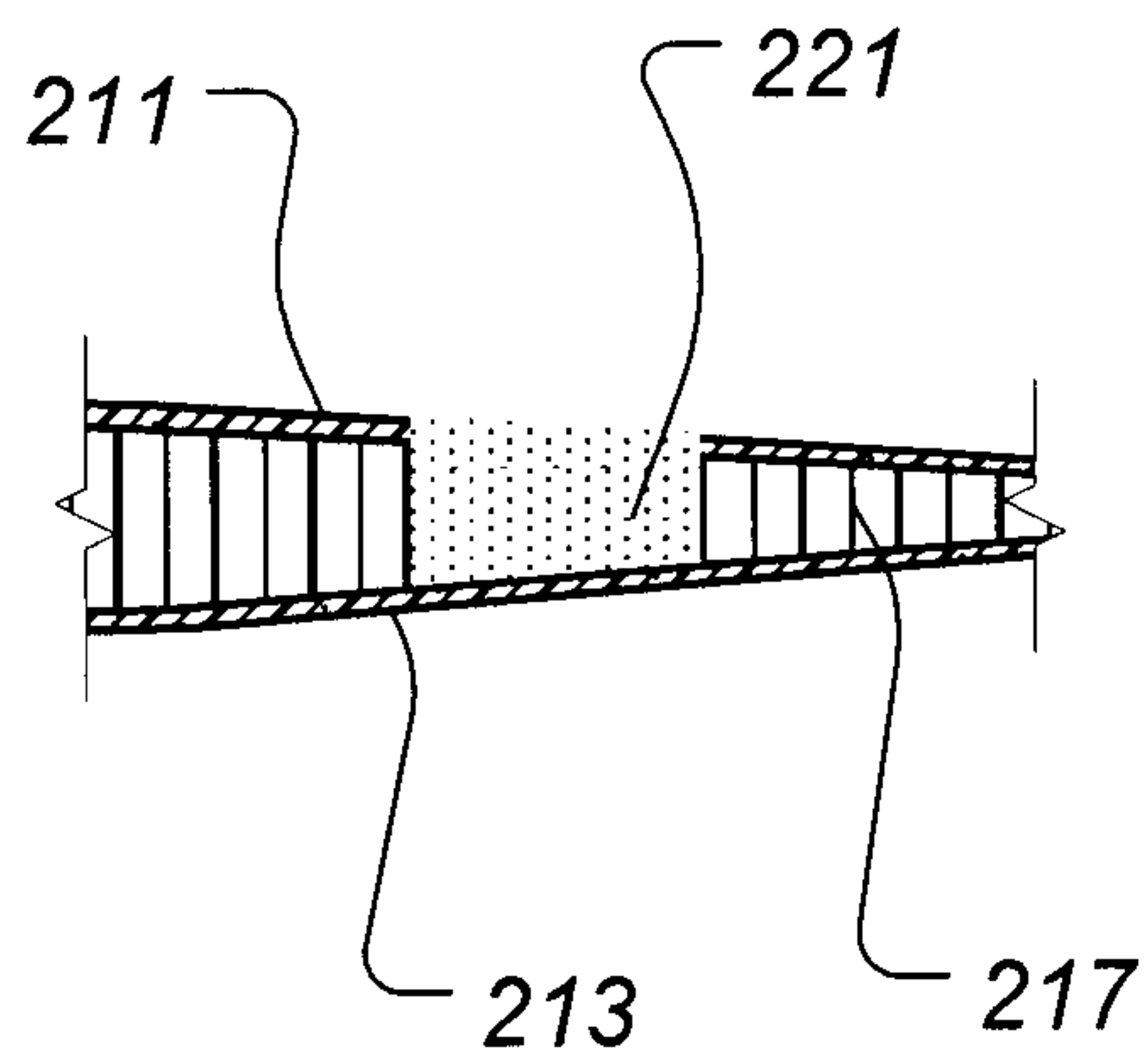

FIG. 11A

7 / 18

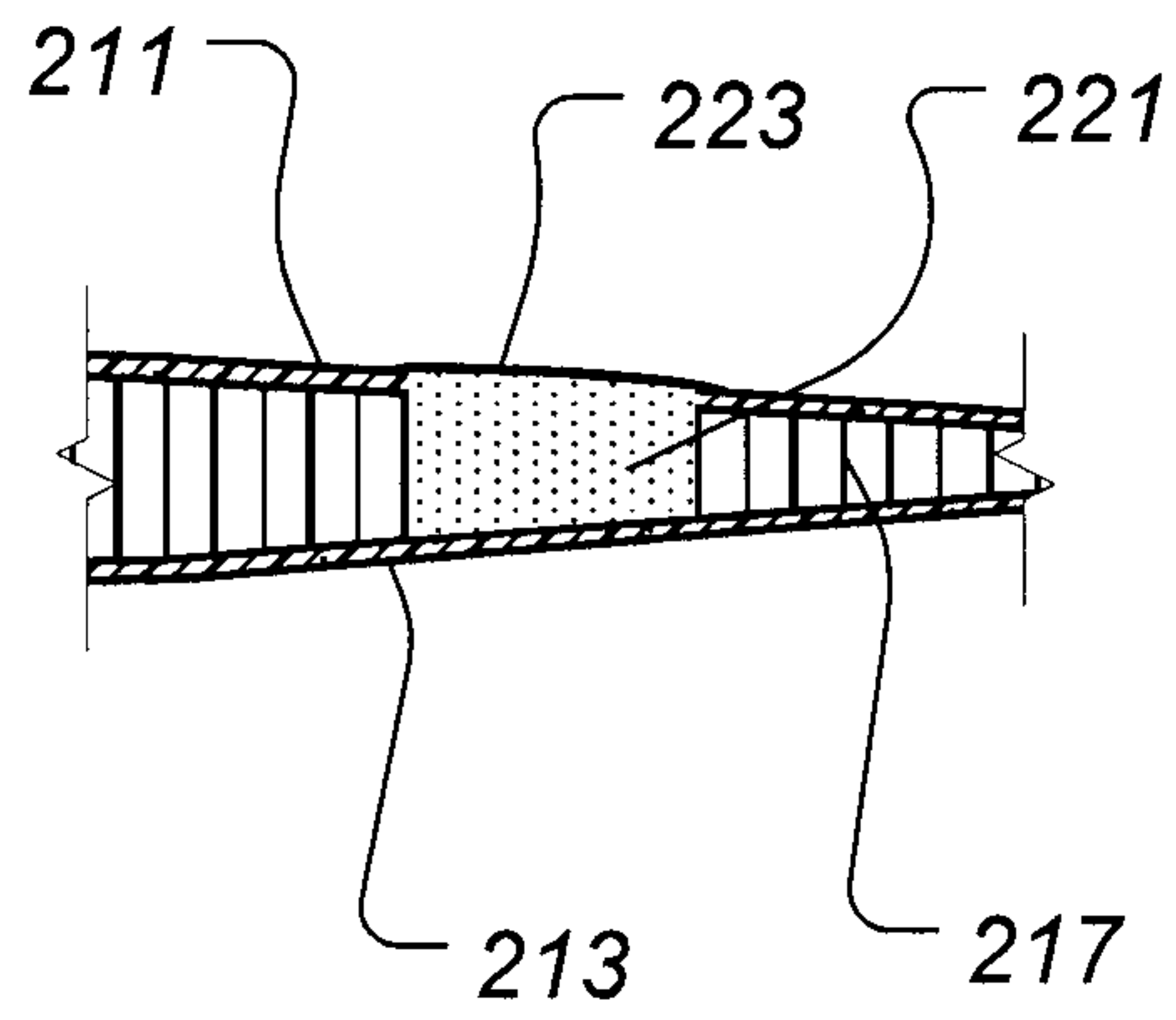

FIG. 11B

8 / 18

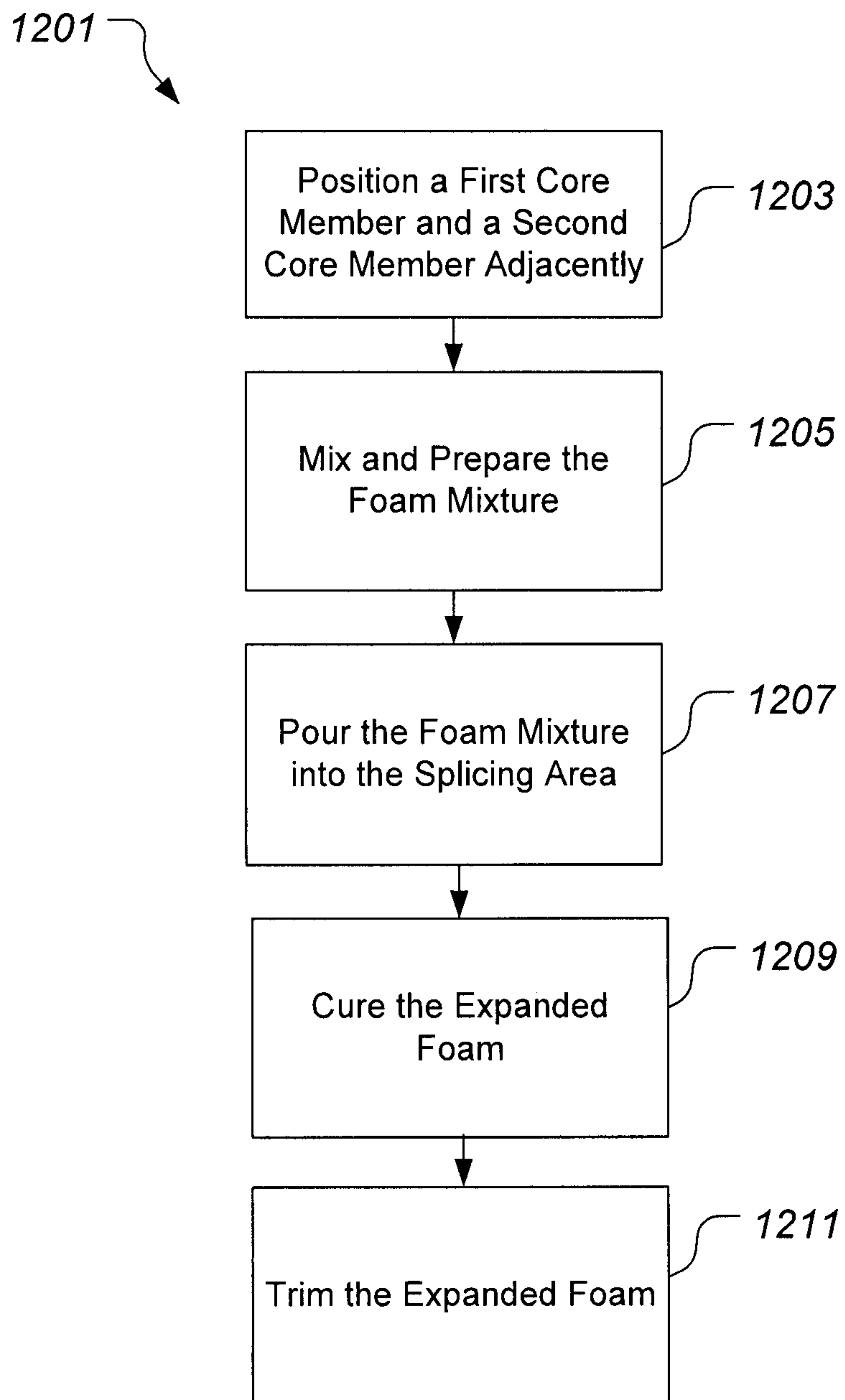

FIG. 12

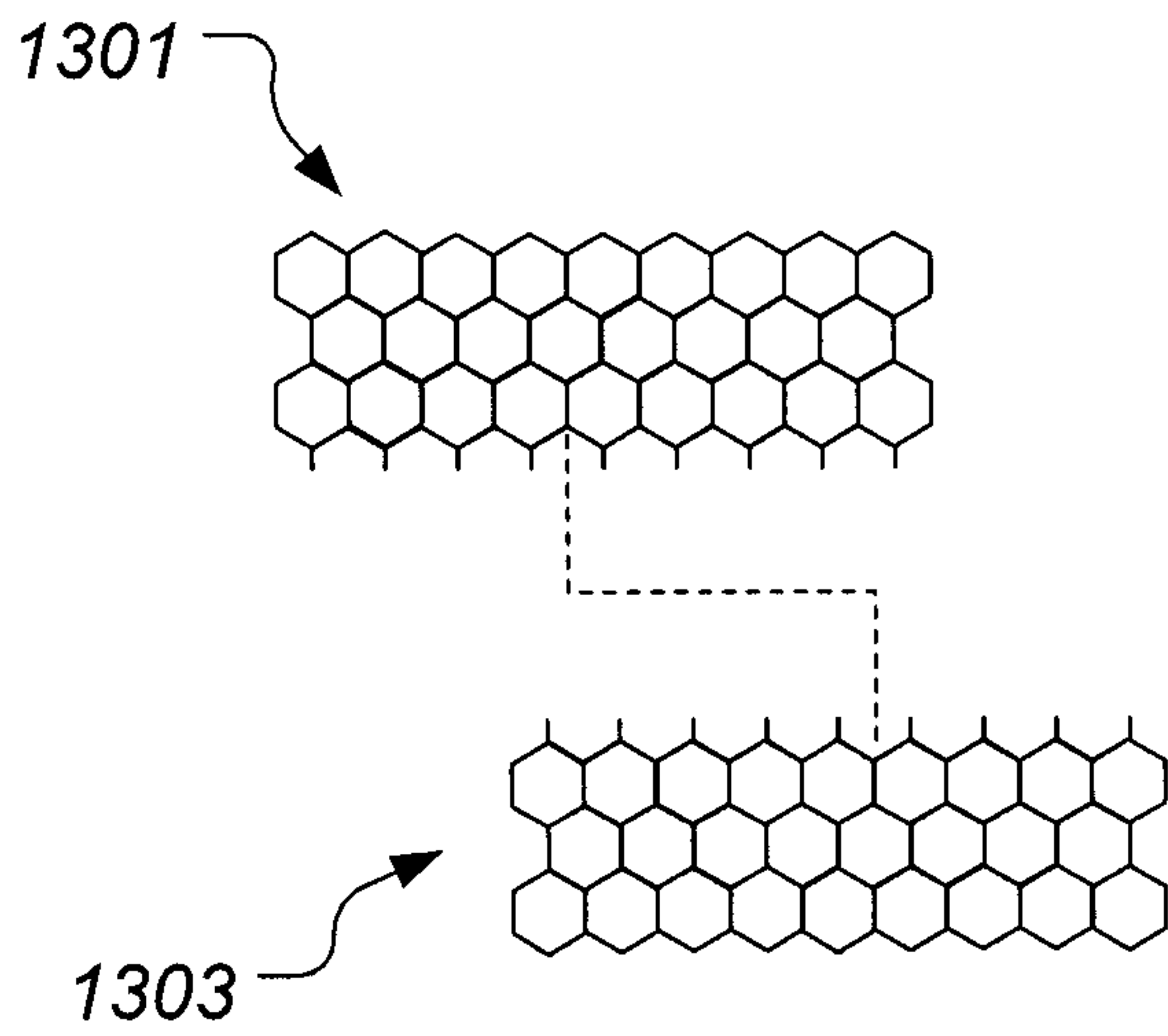

FIG. 13

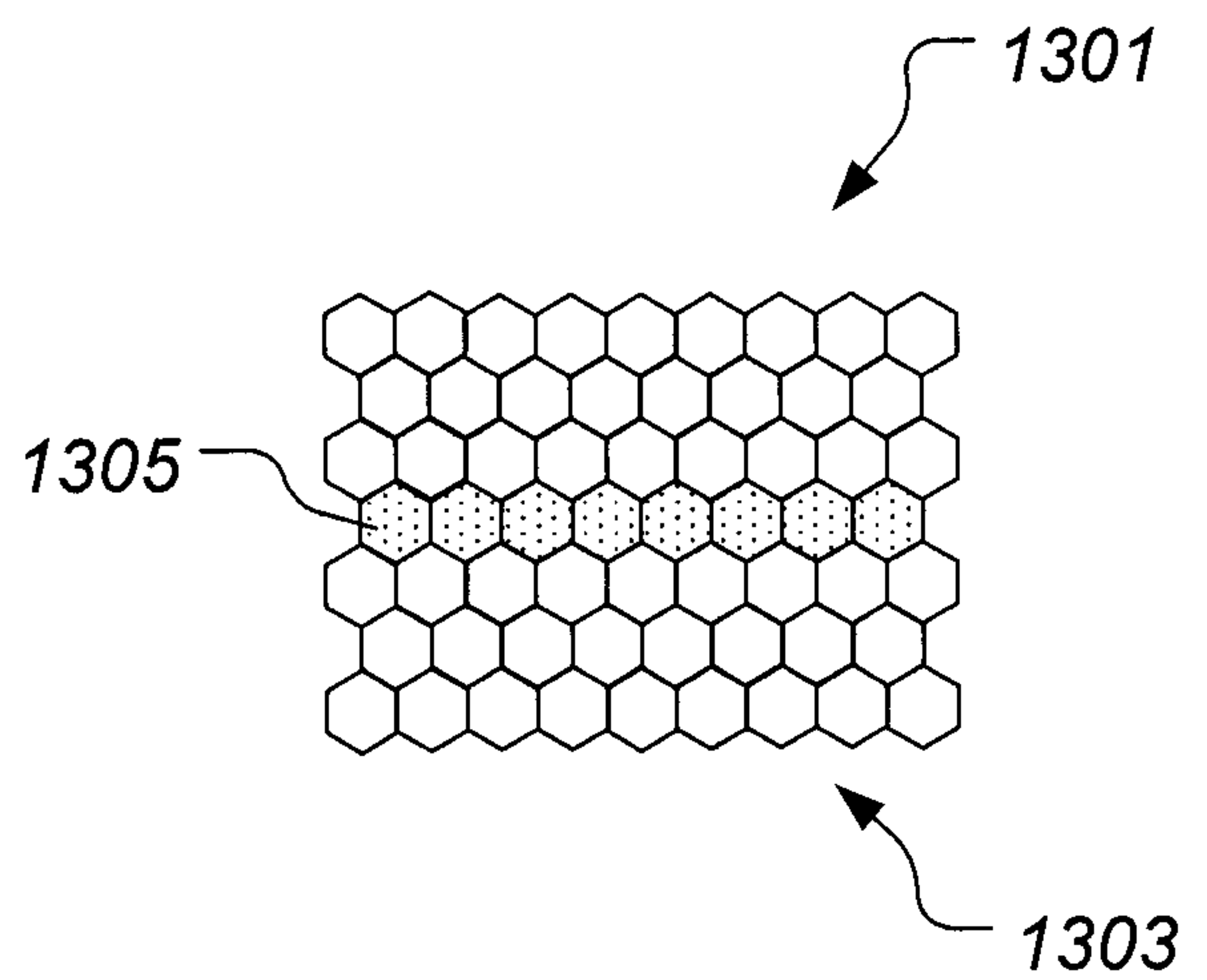

FIG. 14

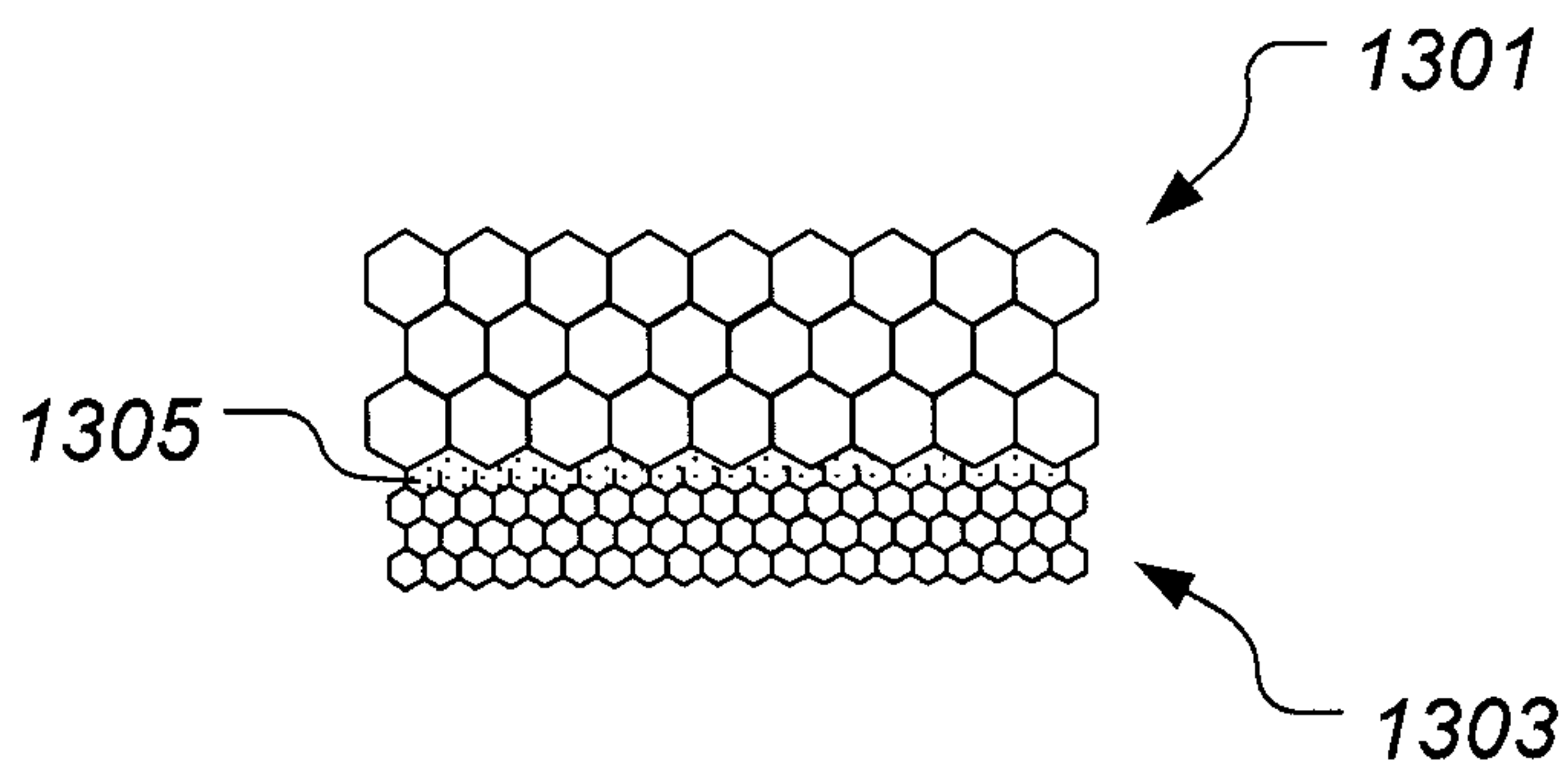

FIG. 15

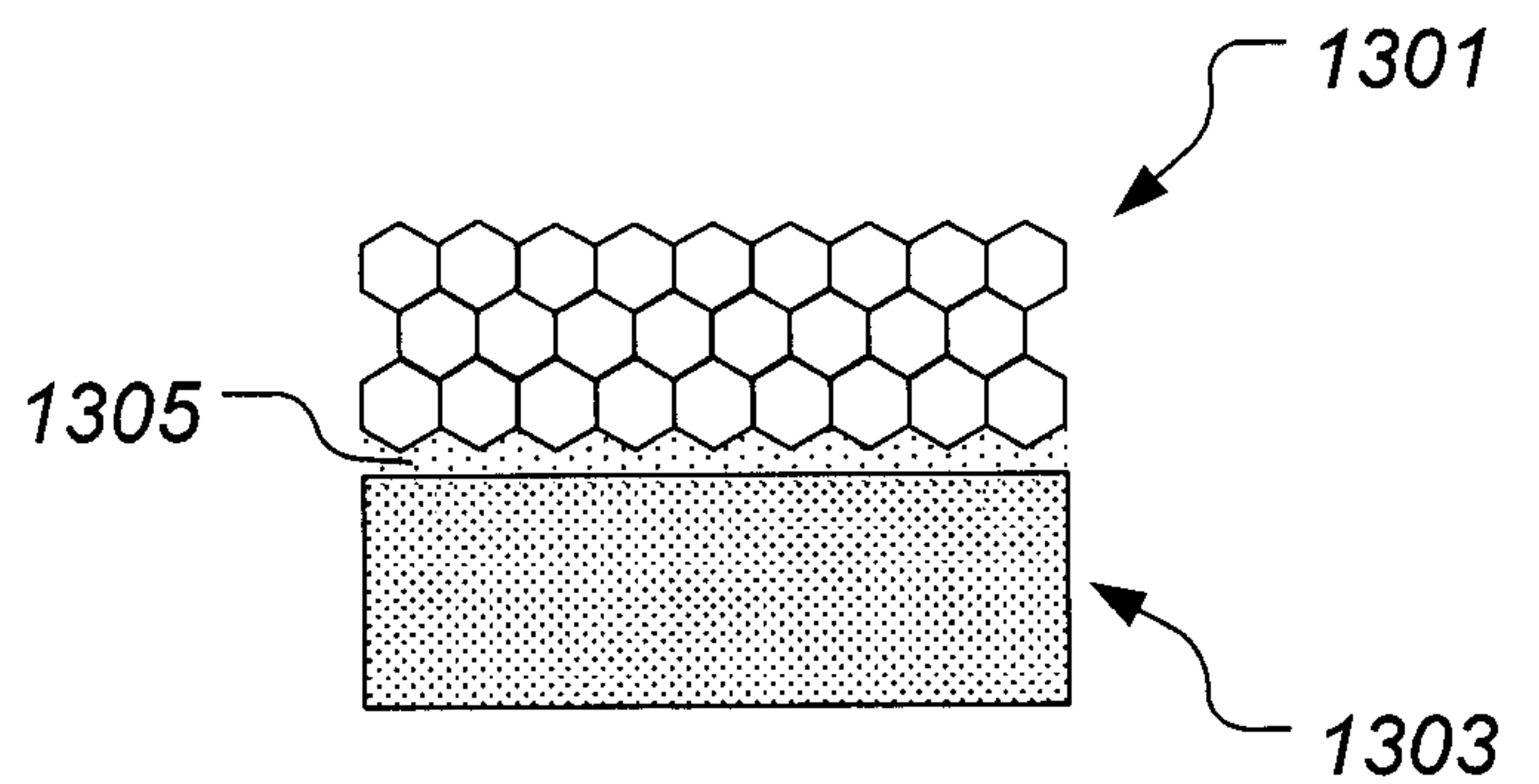

FIG. 16

10 / 18

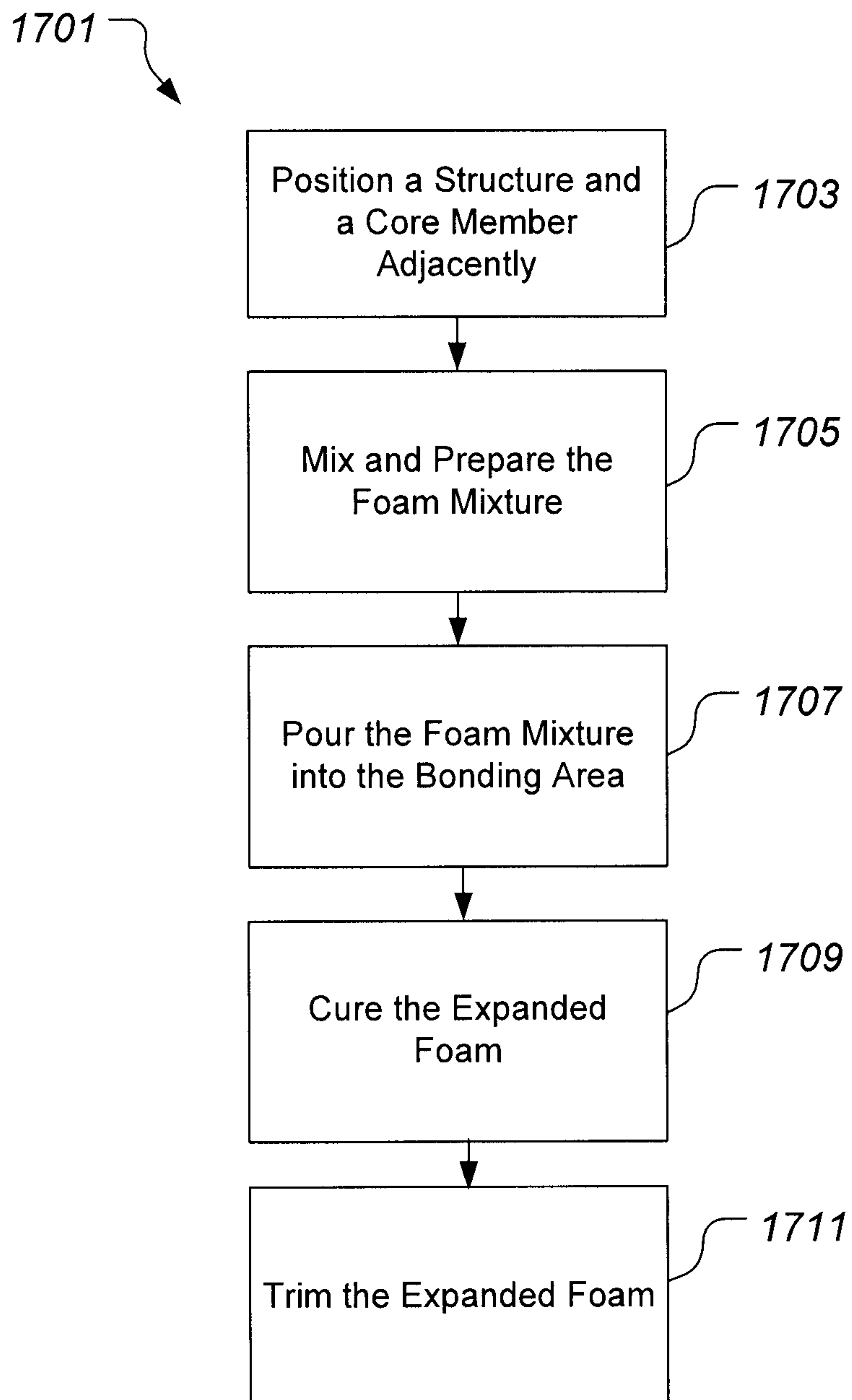

FIG. 17

11 / 18

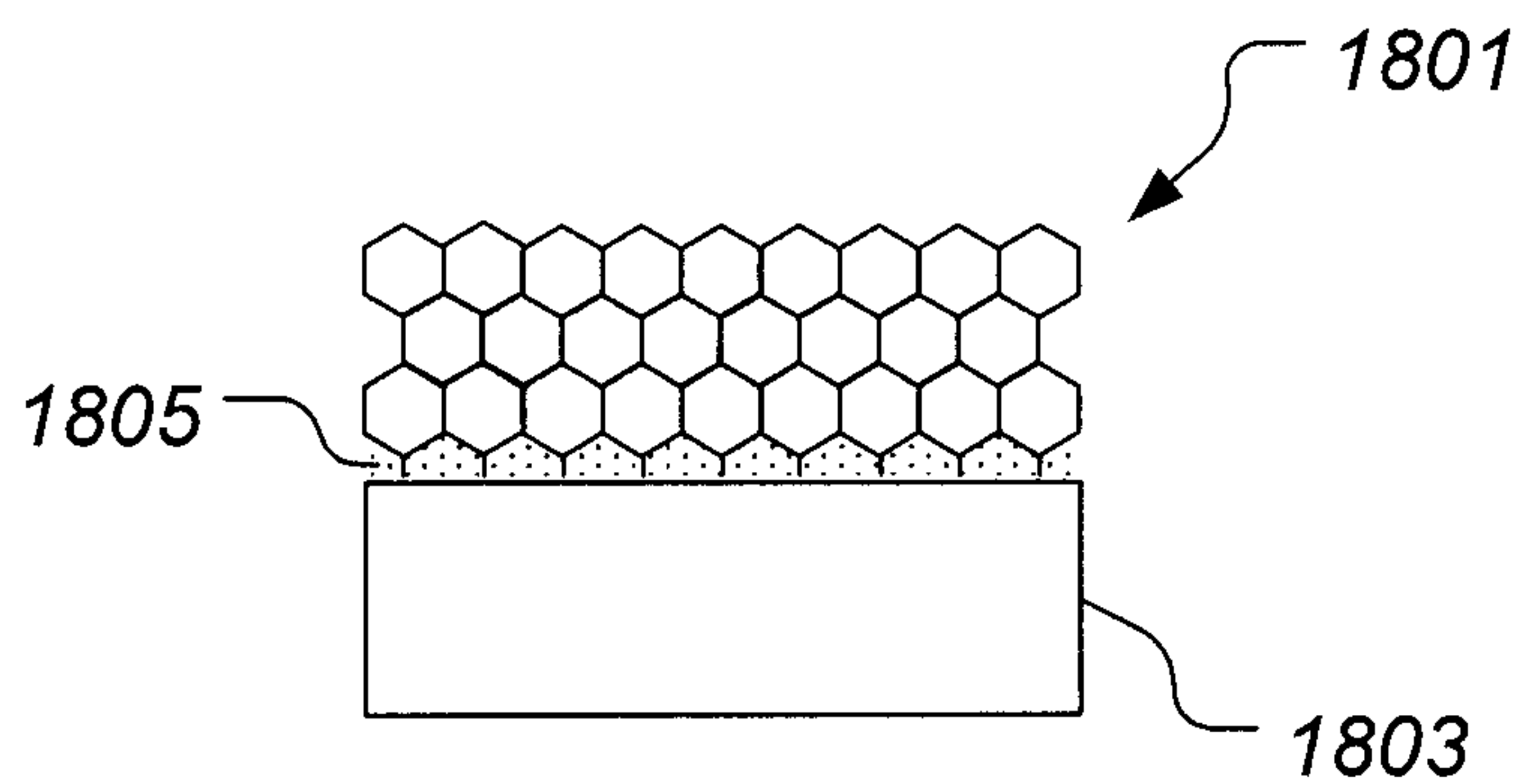

FIG. 18

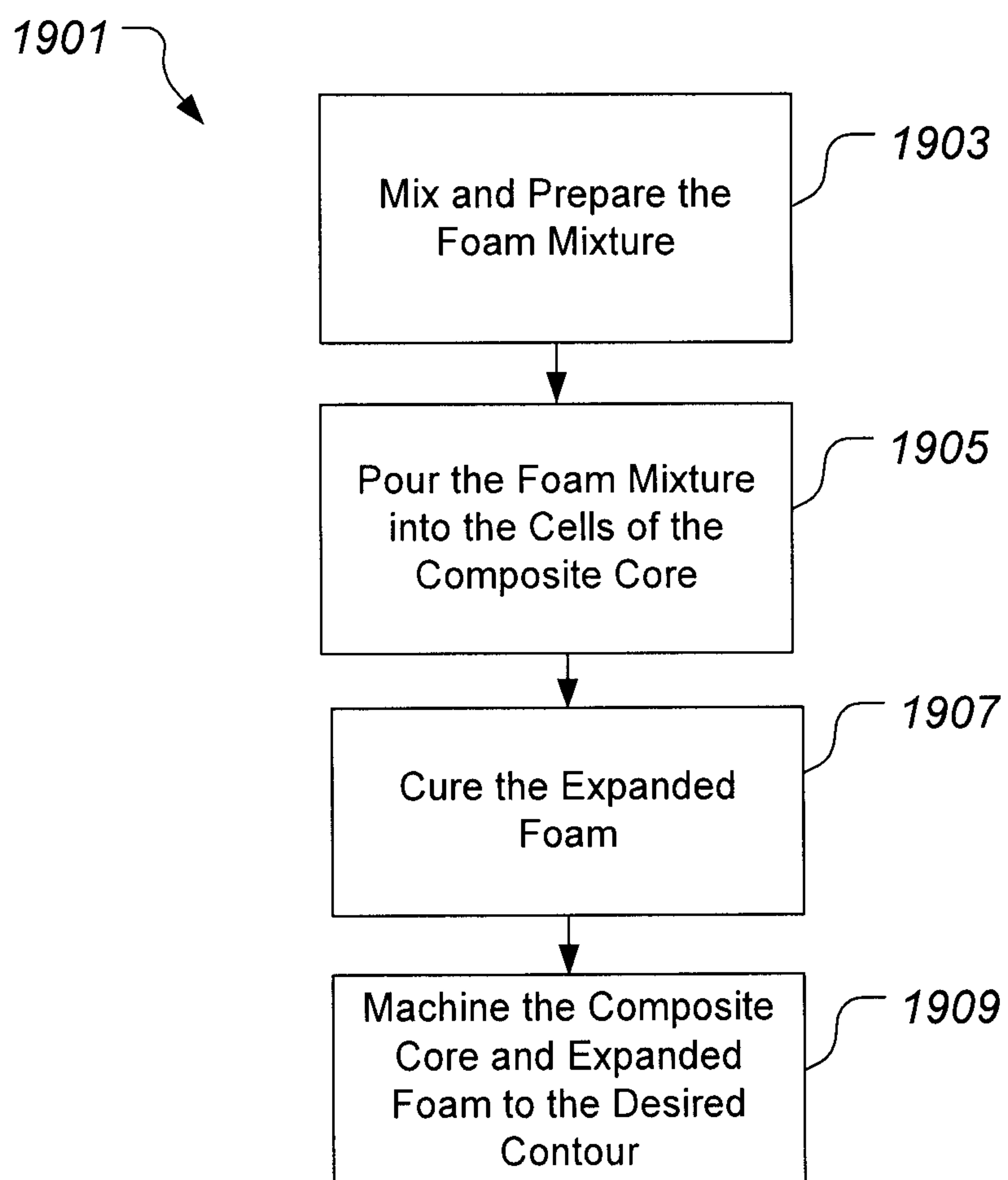

FIG. 19

12 / 18

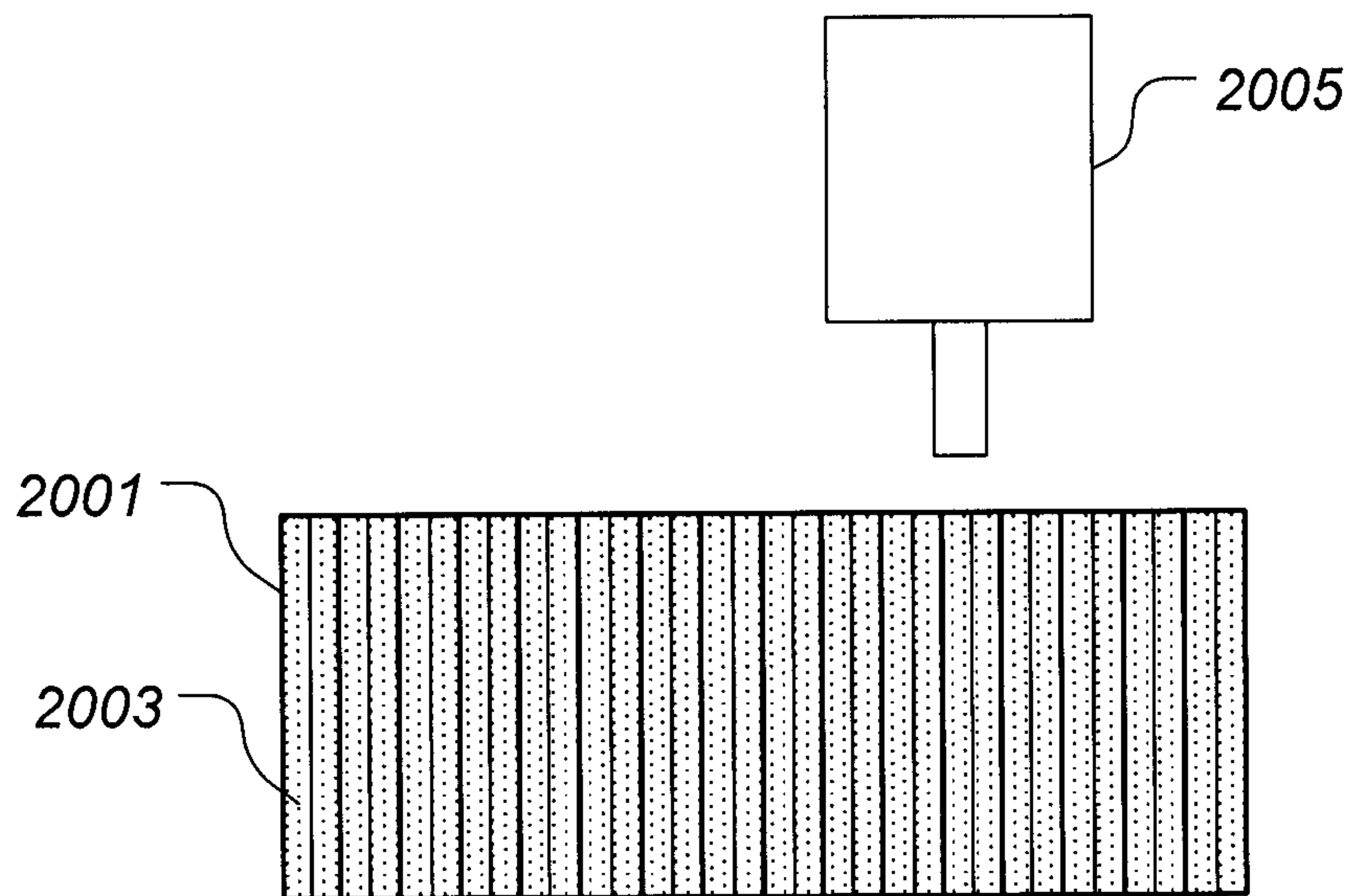

FIG. 20

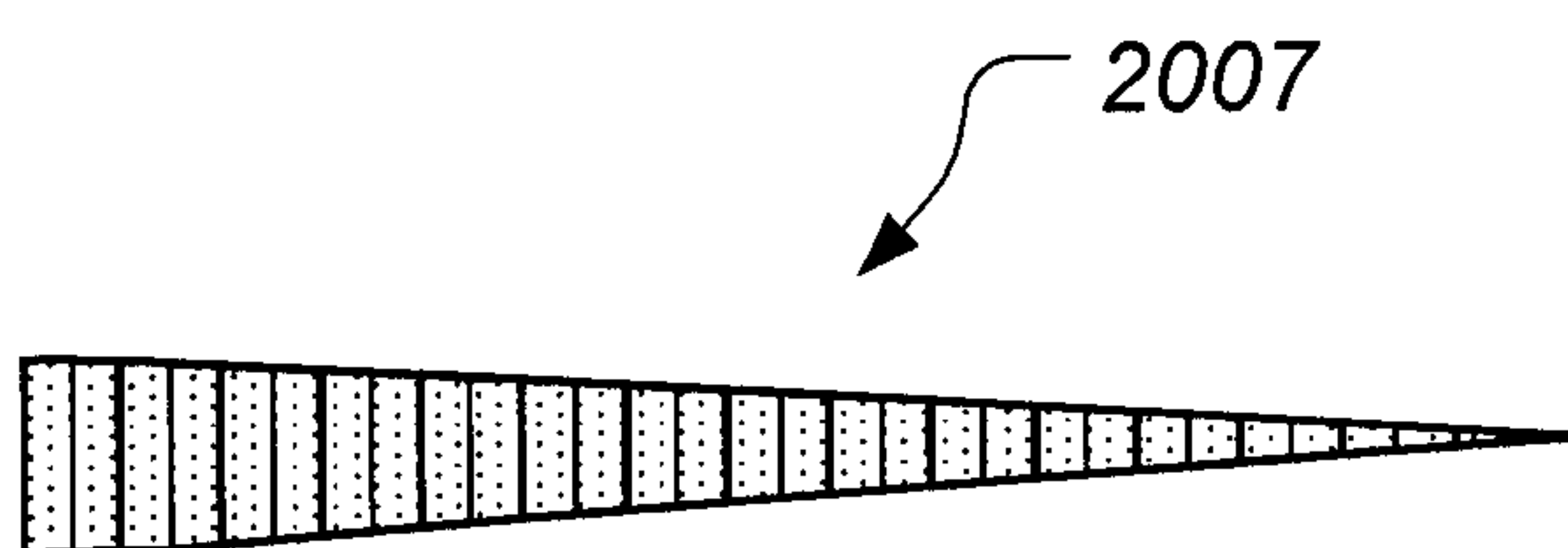

FIG. 21

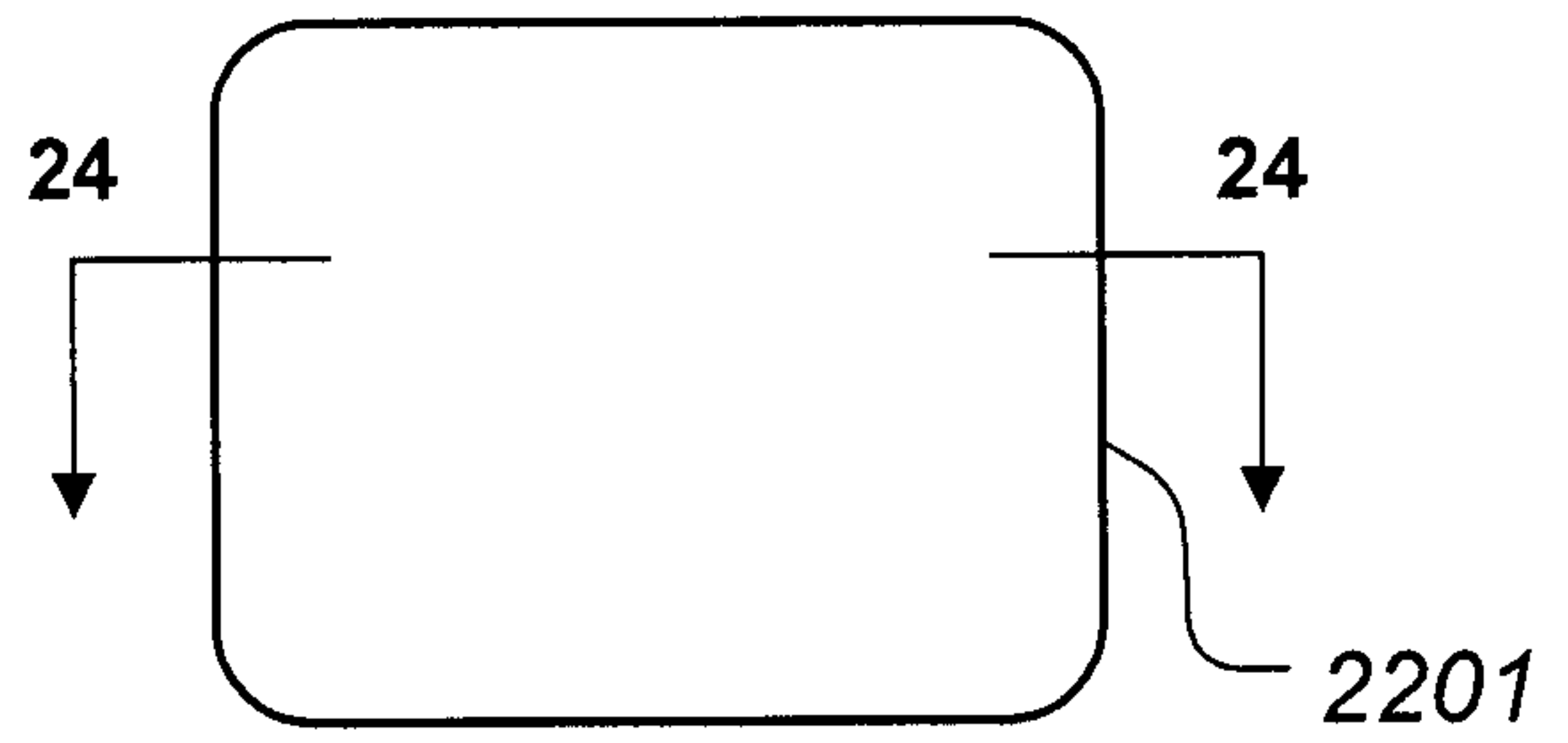

FIG. 22

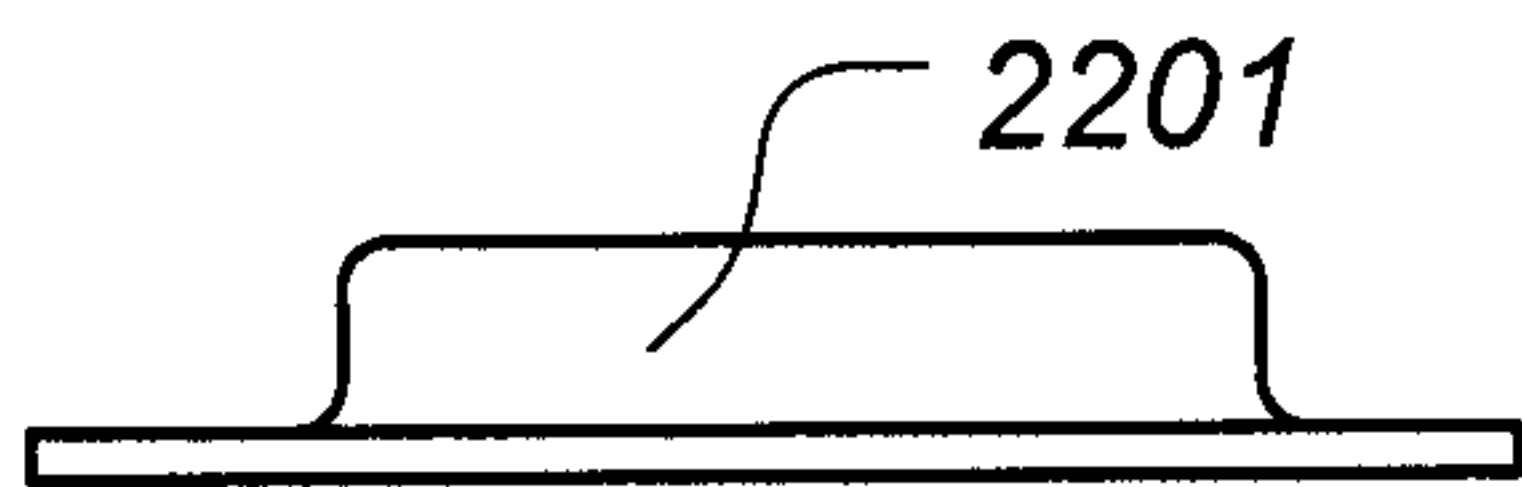

FIG. 23

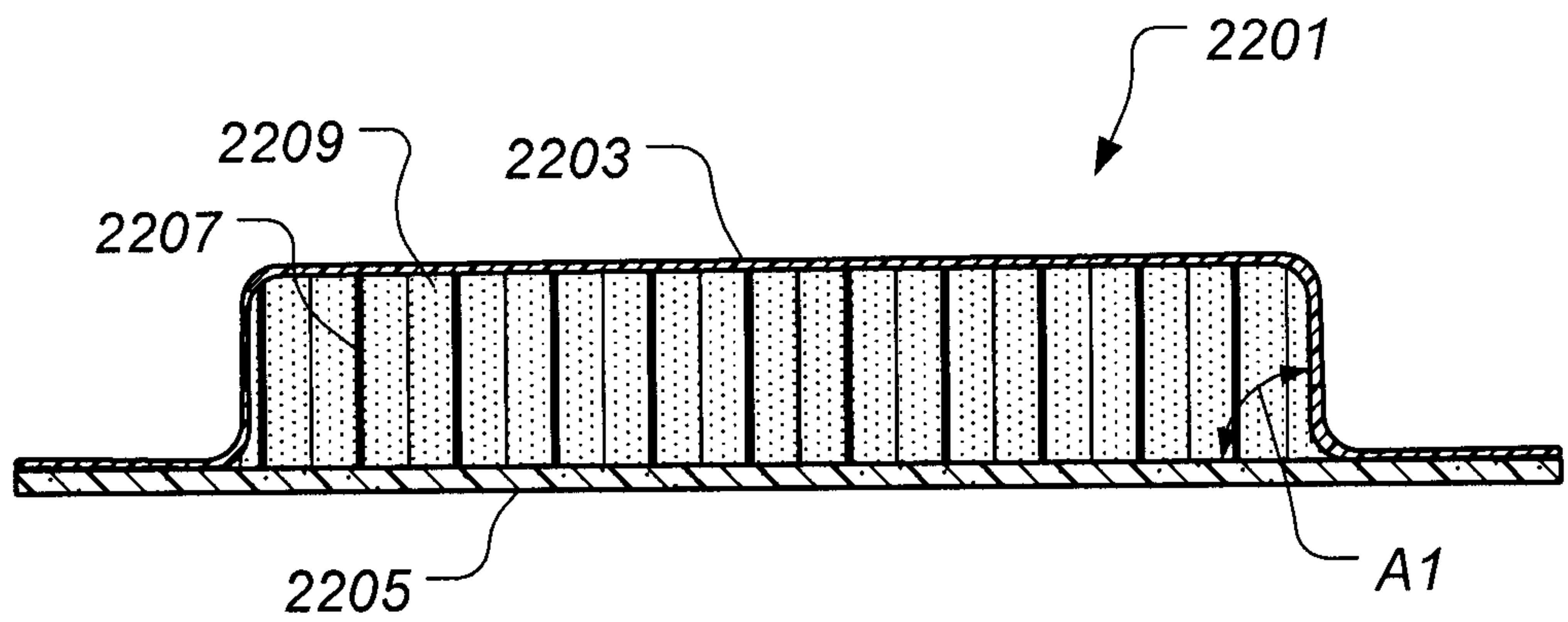

FIG. 24

14 / 18

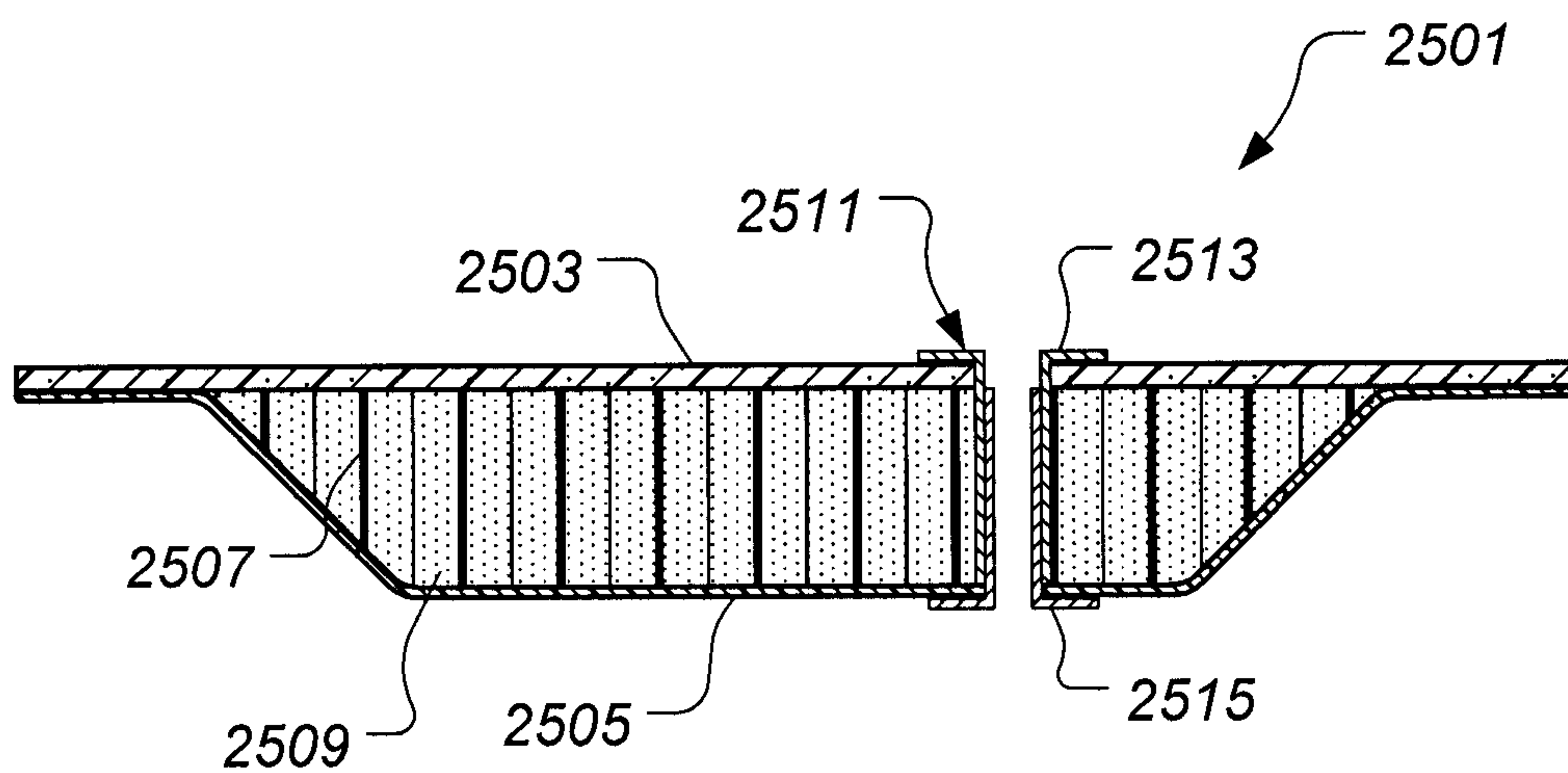

FIG. 25

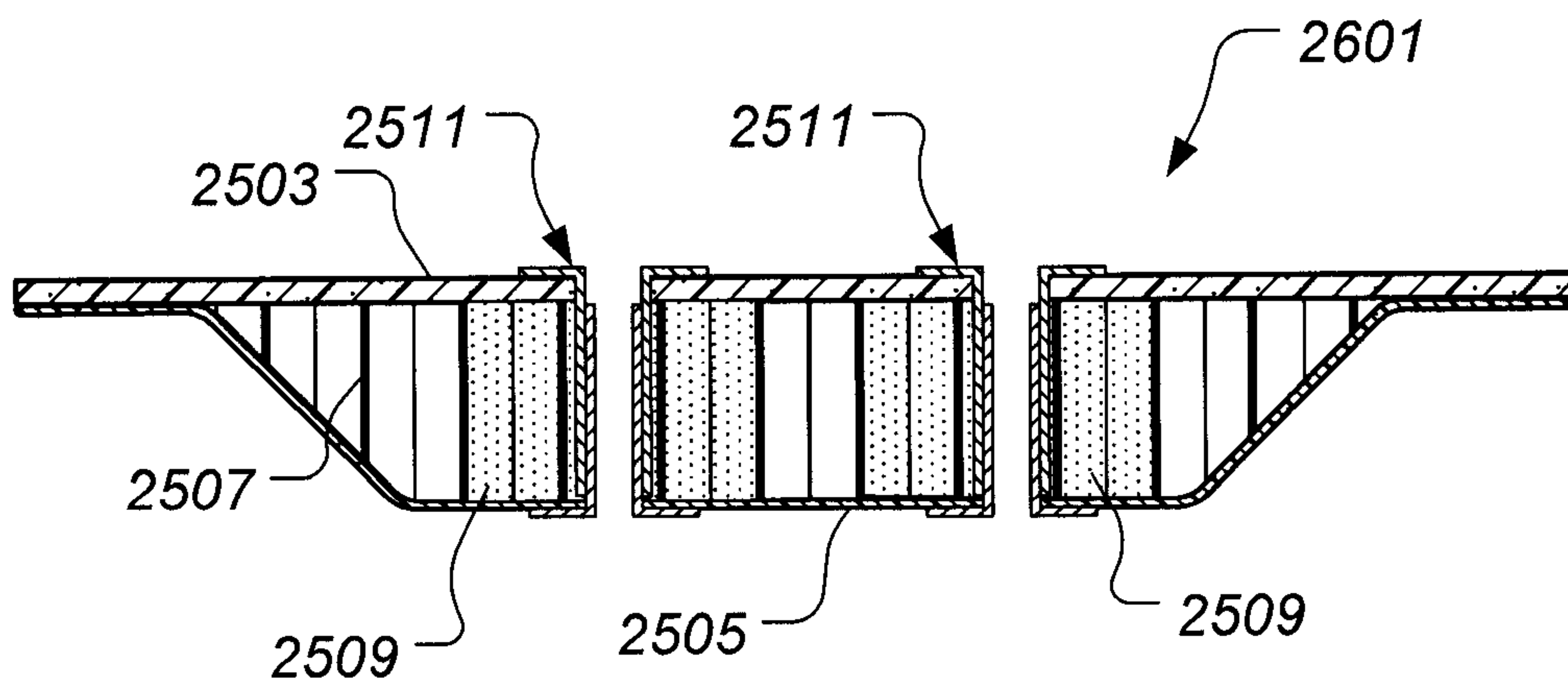

FIG. 26

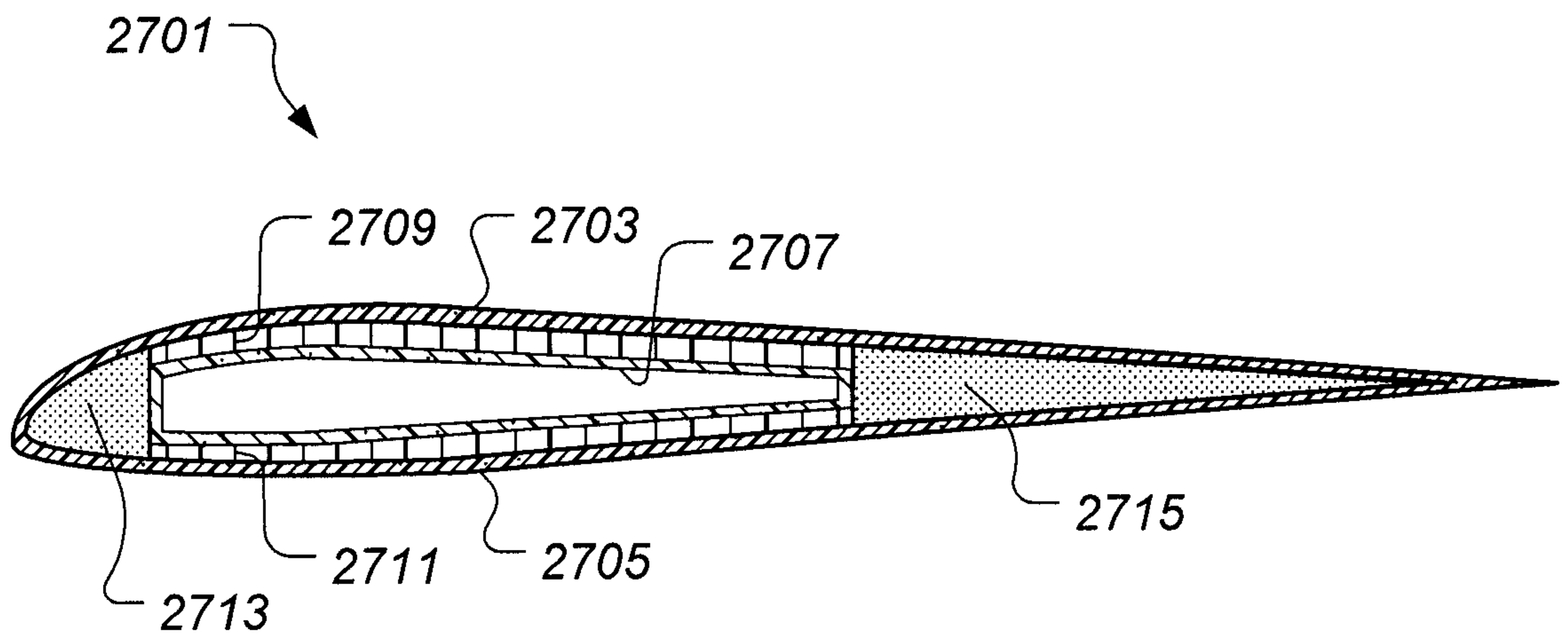

FIG. 27

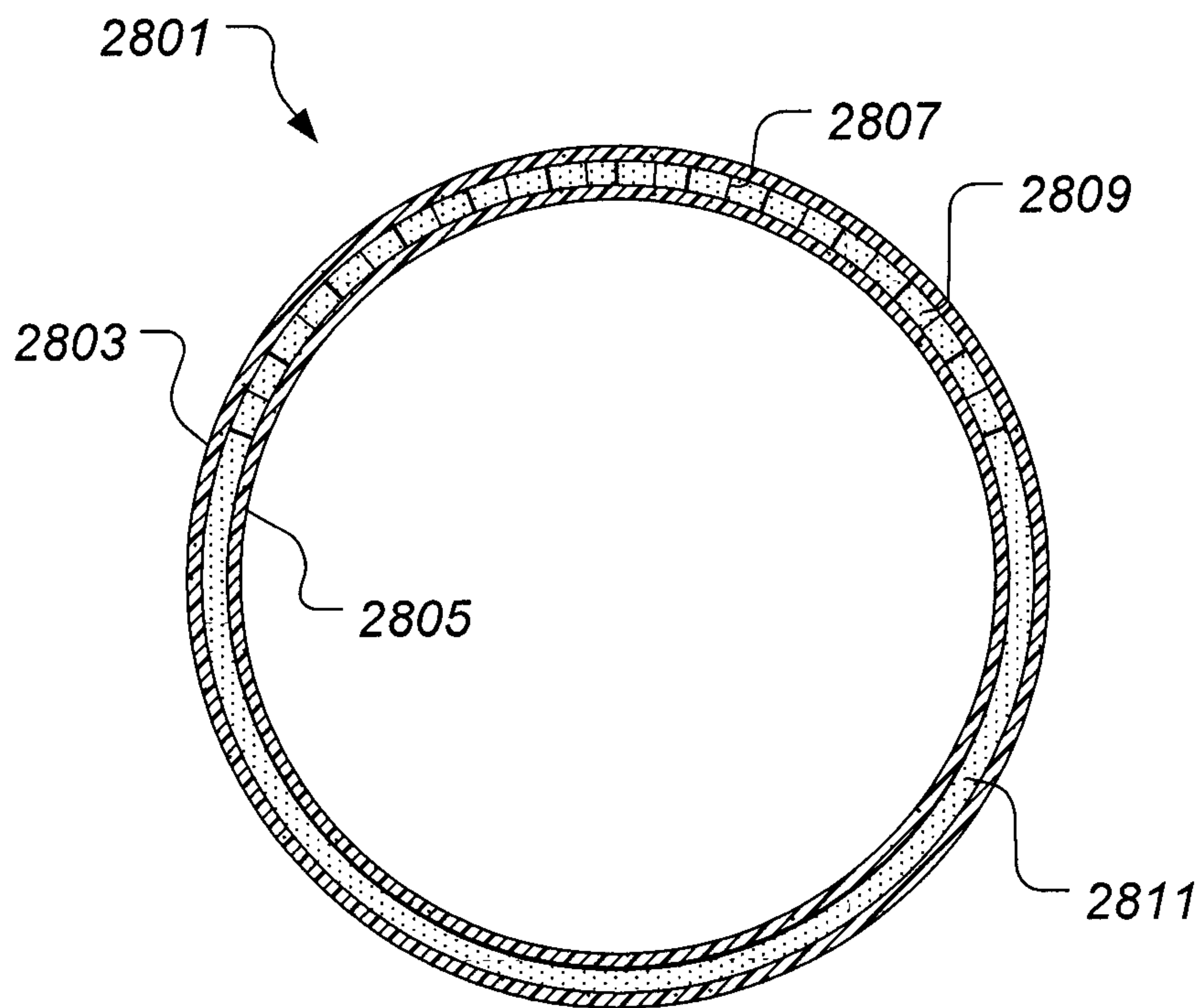

FIG. 28

16 / 18

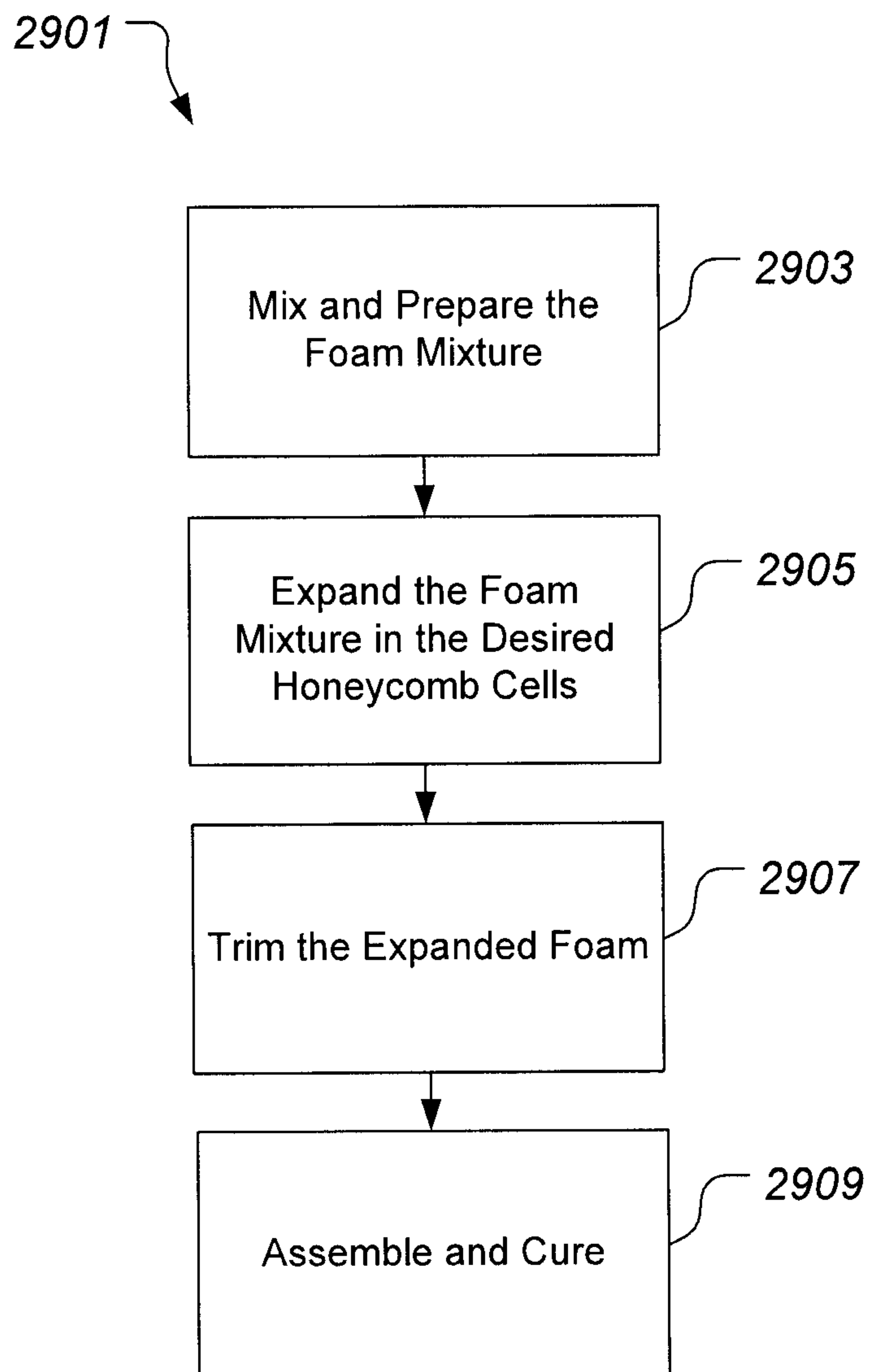

FIG. 29

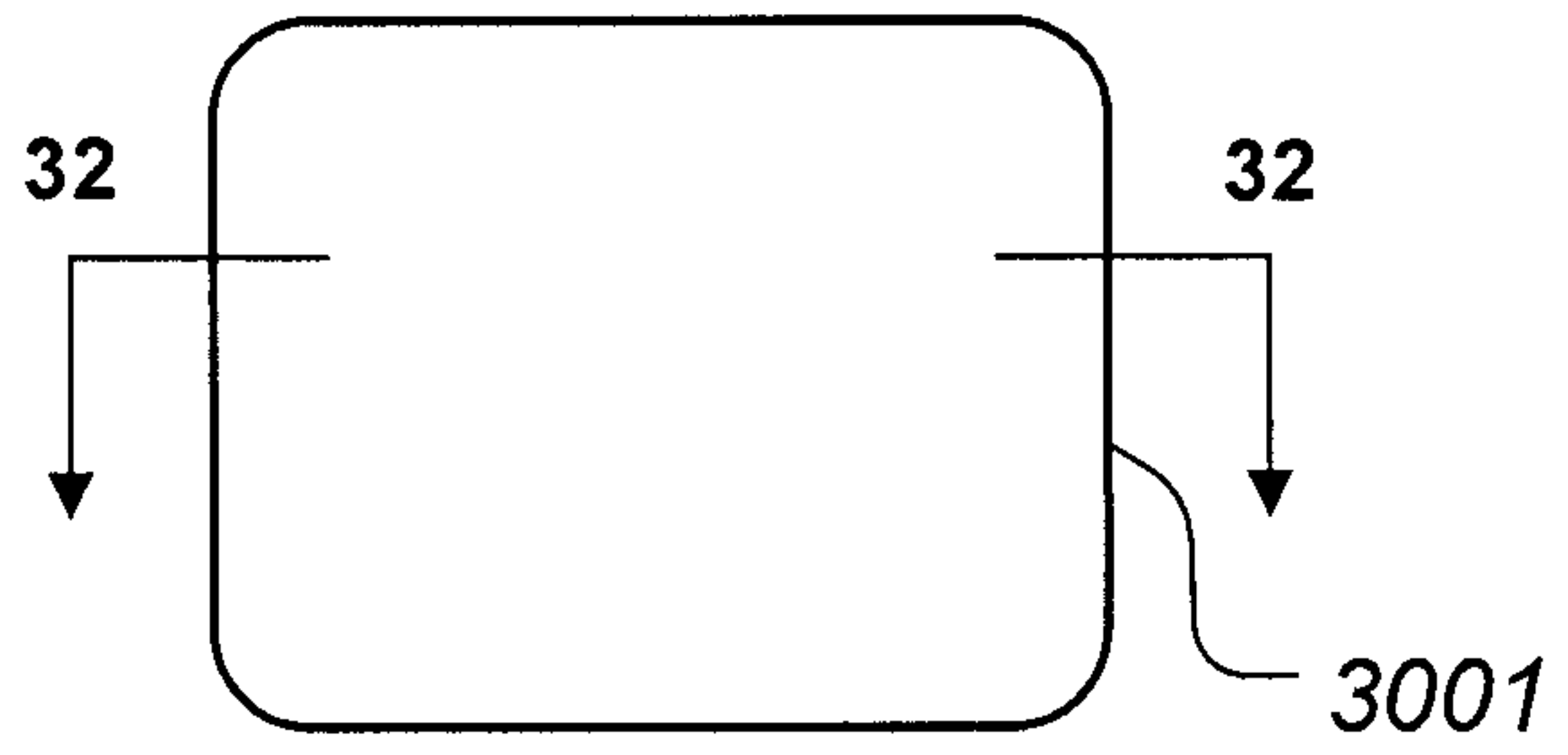

FIG. 30

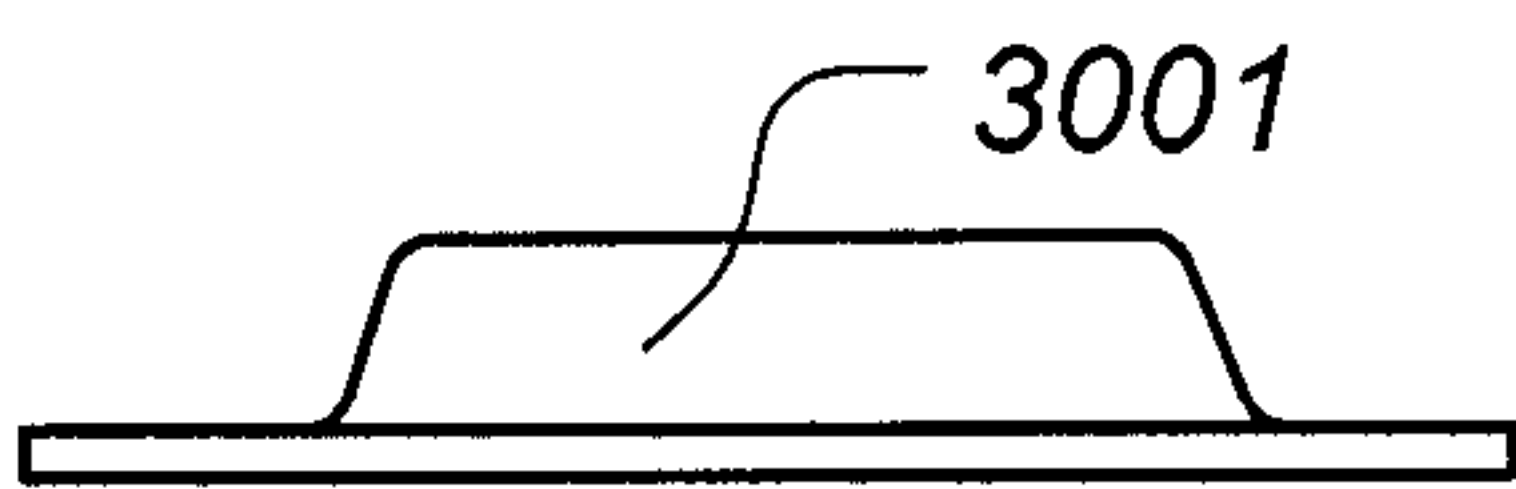

FIG. 31

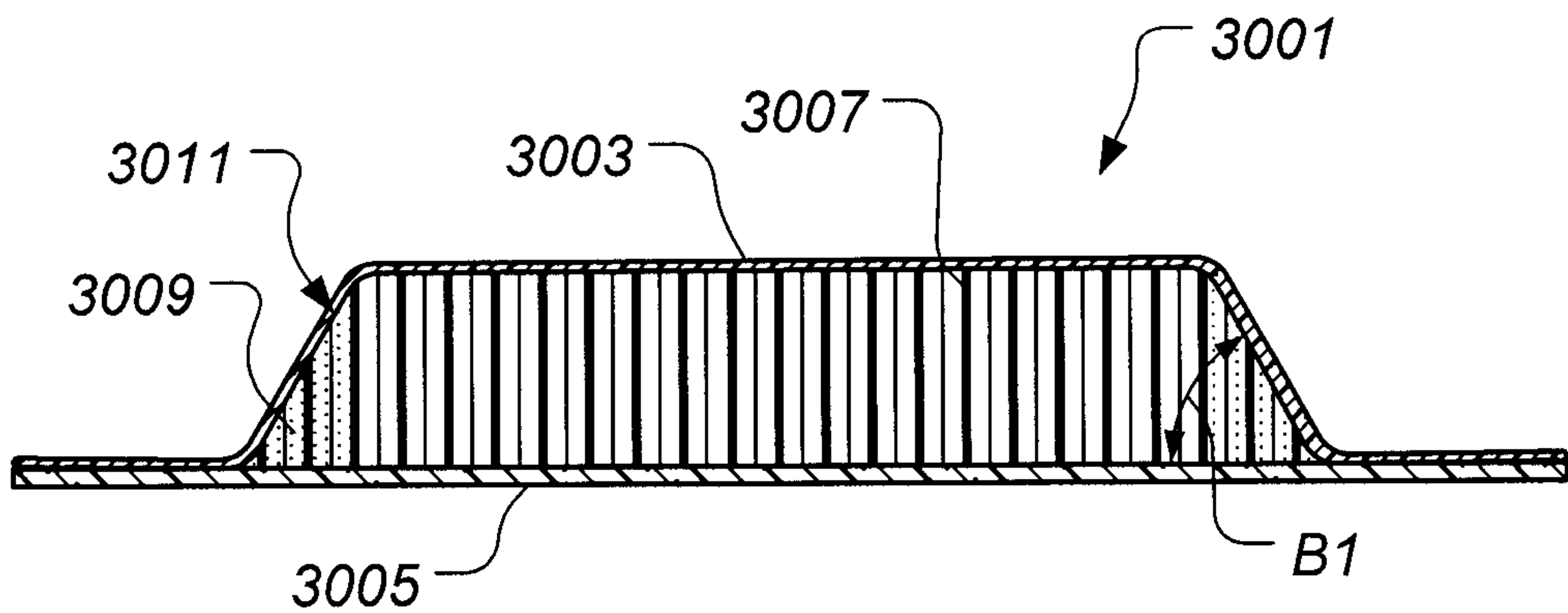

FIG. 32

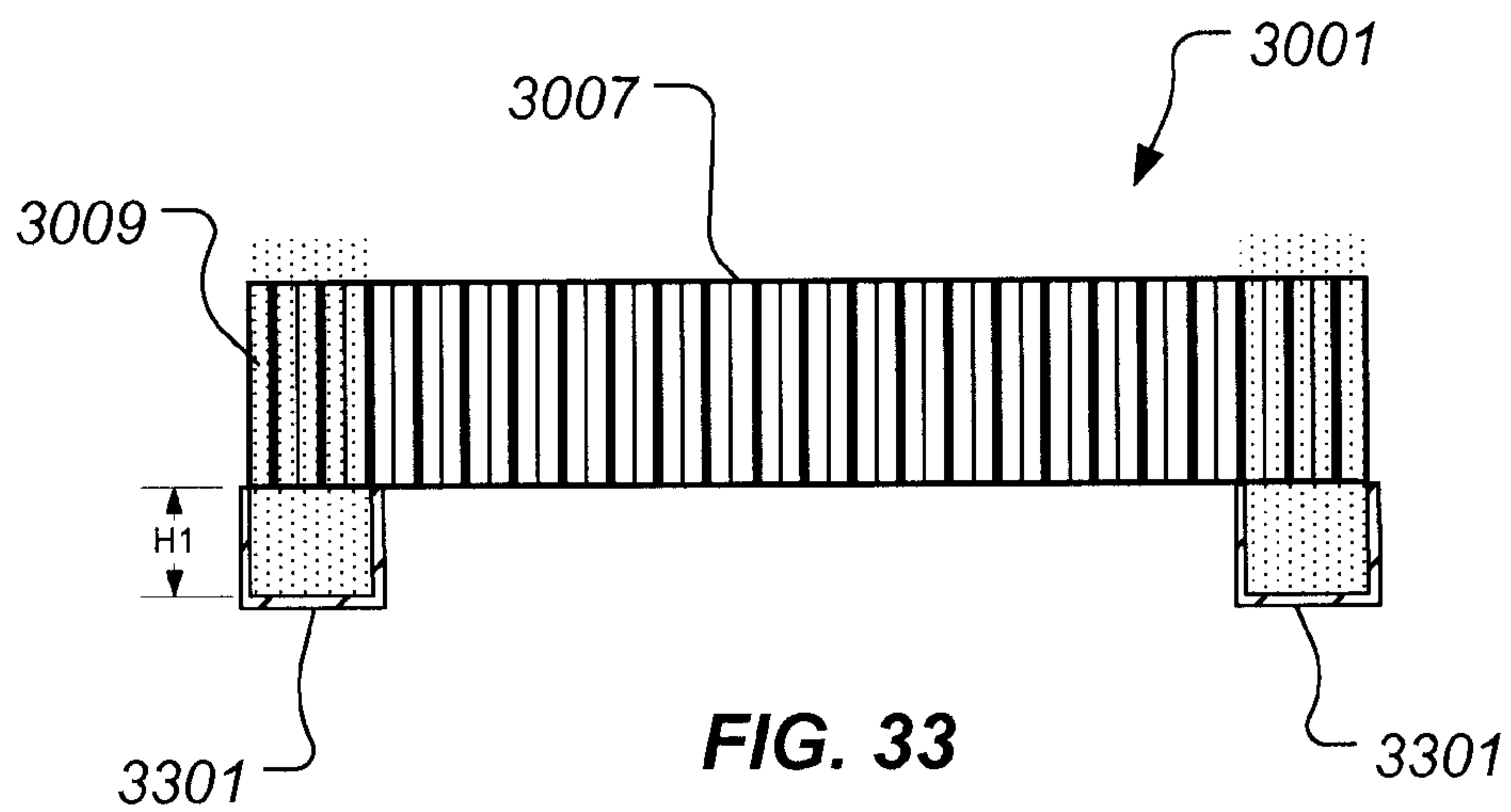

FIG. 33

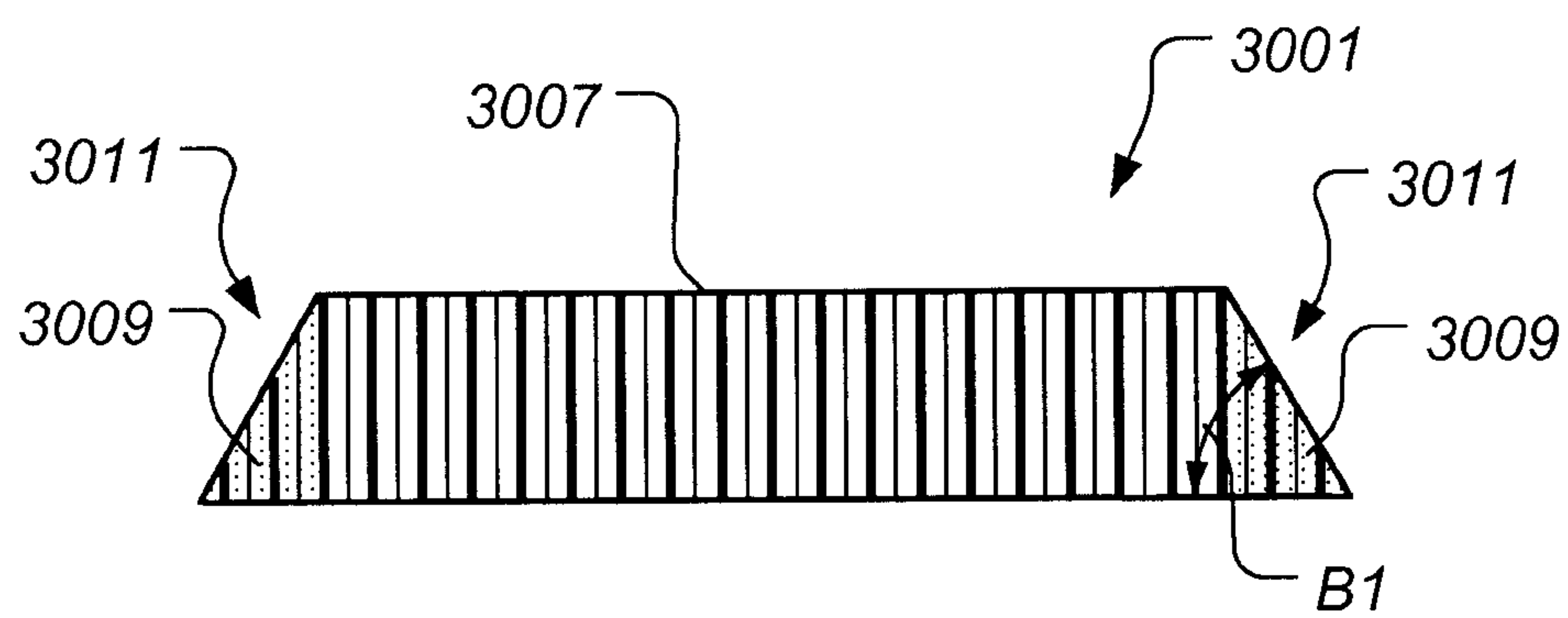

FIG. 34

