

(19) World Intellectual Property
Organization
International Bureau



(43) International Publication Date
4 March 2004 (04.03.2004)

PCT

(10) International Publication Number
WO 2004/017868 A1

- (51) International Patent Classification⁷: **A61F 2/06**
 - (21) International Application Number:
PCT/US2003/026561
 - (22) International Filing Date: 25 August 2003 (25.08.2003)
 - (25) Filing Language: English
 - (26) Publication Language: English
 - (30) Priority Data:
60/405,367 23 August 2002 (23.08.2002) US
 - (71) Applicants: **WILLIAM A. COOK AUSTRALIA PTY. LTD.** [AU/AU]; 12 Electronics Street, Brisbane Technology Park, Eight Mile Plains, Brisbane, QLD 4113 (AU). **COOK INCORPORATED** [US/US]; 750 North Daniel's Way, P.O. Box 489, Bloomington, IN 47402-0489 (US). **WILLIAM COOK EUROPE APS** [DK/DK]; Sandet 6, DK-4632 Bjaeverskov (DK).
 - (72) Inventor: **HARTLEY, David, Ernest**; 2 View Street, Subiaco, WA 6008 (AU).
 - (74) Agent: **GODLEWSKI, Richard, J.**; P.O. Box 2269, Bloomington, IN 47402 (US).
 - (81) Designated States (*national*): AE, AG, AL, AM, AT, AU, AZ, BA, BB, BG, BR, BY, BZ, CA, CH, CN, CO, CR, CU, CZ, DE, DK, DM, DZ, EC, EE, ES, FI, GB, GD, GE, GH, GM, HR, HU, ID, IL, IN, IS, JP, KE, KG, KP, KR, KZ, LC, LK, LR, LS, LT, LU, LV, MA, MD, MG, MK, MN, MW, MX, MZ, NI, NO, NZ, OM, PG, PH, PL, PT, RO, RU, SC, SD, SE, SG, SK, SL, SY, TJ, TM, TN, TR, TT, TZ, UA, UG, UZ, VC, VN, YU, ZA, ZM, ZW.
 - (84) Designated States (*regional*): ARIPO patent (GH, GM, KE, LS, MW, MZ, SD, SL, SZ, TZ, UG, ZM, ZW), Eurasian patent (AM, AZ, BY, KG, KZ, MD, RU, TJ, TM), European patent (AT, BE, BG, CH, CY, CZ, DE, DK, EE, ES, FI, FR, GB, GR, HU, IE, IT, LU, MC, NL, PT, RO, SE, SI, SK, TR), OAPI patent (BF, BJ, CF, CG, CI, CM, GA, GN, GQ, GW, ML, MR, NE, SN, TD, TG).
- Published:**
— with international search report

[Continued on next page]

(54) Title: ASYMMETRIC STENT GRAFT ATTACHMENT

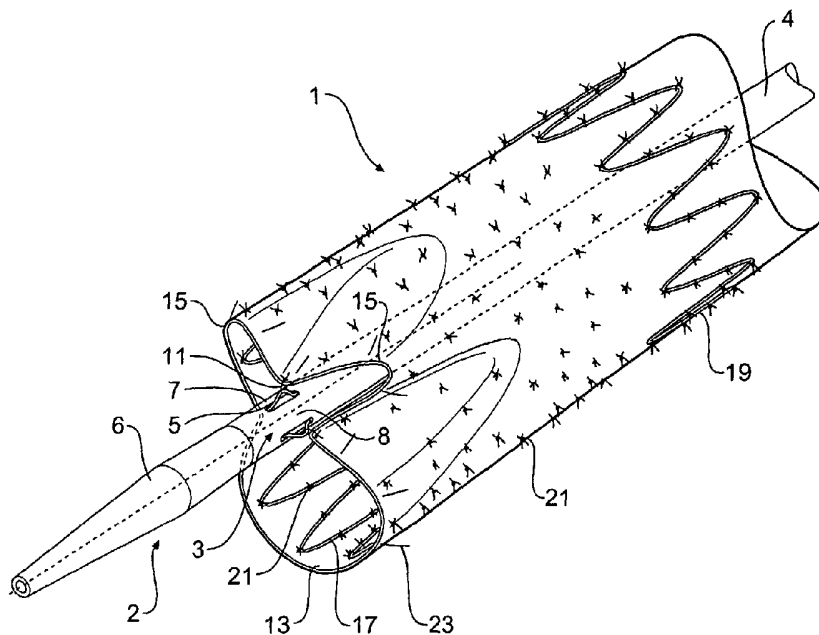

(57) Abstract: An arrangement for mounting a stent graft prosthesis (1) onto a deployment device (2) with a retention arrangement (3) which includes retention at a number of points of the circumference of the proximal end of the stent graft prosthesis (1). The arrangement provides a greater circumferential distance (13) between two adjacent retention points (9) than other of the points. When the deployment device is deployed in a curved lumen such as the thoracic arch it is oriented so that the greater circumferential distance (13) is on the inner side of the curve.

WO 2004/017868 A1



For two-letter codes and other abbreviations, refer to the "Guidance Notes on Codes and Abbreviations" appearing at the beginning of each regular issue of the PCT Gazette.

ASYMMETRIC STENT GRAFT ATTACHMENT

DescriptionTechnical Field

5 This invention relates to deployment of endovascular stent grafts and in particular the deployment of endovascular stent grafts into lumens in the human or animal body such as into the thoracic arch region of the aorta.

Background of the Invention

10 This specification will be discussed in relation to its application to treatment of aortic arch disease, that is to treatment in the thoracic arch of a patient but the invention is not so limited and is applicable to any lumen of the human or animal body and particularly curved lumens.

15 Throughout this specification the term distal with respect to a portion of the aorta, a deployment device or a prosthesis such as a stent graft is intended to mean the end of the aorta, deployment device or prosthesis such as a stent graft further away in the direction of blood flow from the heart and the term proximal is intended to mean the portion of the aorta, deployment device or end of the prosthesis nearer to the heart. For other lumens within the human or animal body the terms caudal and cranial respectively should be understood.

20 When deploying a stent graft which is substantially cylindrical in a curved aorta there is a danger that the proximal end of the stent graft, that is the end nearer the heart, will not lie flat against the walls of a aorta and blood flow can get underneath the edge of the graft particularly on the inner side of the curve of the thoracic arch and cause the stent graft to buckle and close off thereby causing serious problems.

Summary of the Invention

25 It is the object of this invention to provide a method and arrangement for mounting a stent graft onto a deployment device and deploying the stent graft in an attempt to overcome the above problems.

30 In one form therefore, although this may not necessarily be the only or broadest form the invention is said to reside in a stent graft prosthesis mounted to

a deployment device and adapted to be deployed in a curved lumen, the curved lumen having an inner side and an outer side of the curve, the stent graft prosthesis being temporarily mounted to the deployment device at at least one end of the prosthesis by a retention arrangement, the retention arrangement of the stent graft prosthesis including a retention to the deployment device at a plurality of points of the circumference of the proximal end of the stent graft prosthesis, there being a greater circumferential distance between two adjacent retention points than other of the points, whereby when the deployment device is deployed in the curved lumen the greater circumferential distance is on the inner side of the curve.

Preferably the retention arrangement includes a fastening to a release mechanism at at least two points of the circumference of the prosthesis whereby a larger and a smaller fold of the graft material is formed.

More preferably three retention points may be used so that one larger and two smaller folds of the graft material are formed.

In an alternative form the invention is said to reside in a deployment device and stent graft prosthesis temporarily mounted thereto and adapted to be deployed in a curved lumen, the curved lumen having an inner side and an outer side of the curve, the deployment device including a deployment catheter and a release mechanism, the stent graft prosthesis comprising a tube of graft material having a first end and a second end and being mounted to the deployment device at at least its first end by a retention arrangement, the retention arrangement including a retention to the deployment device at a plurality of points of the circumference of the proximal end of the stent graft prosthesis, there being a greater circumferential distance between two adjacent retention points than other of the points, and the retention points being provided by the release mechanism being engaged with the graft material, whereby when the deployment device is deployed in the curved lumen the greater circumferential distance is on the inner side of the curve.

Preferably the retention arrangement includes a fastening to a release mechanism at at least two points of the circumference of the prosthesis whereby a larger and a smaller fold of the graft material is formed. Alternatively there may

be three retention points so that one larger and two smaller folds or loops of the graft material are formed. Hence in this form the retention arrangement provides one larger fold and at least one smaller fold of the proximal end of the graft material wherein the larger fold is on the inner side of the curve when the deployment device is deployed in the curved lumen.

Preferably the deployment catheter includes a guide wire catheter and a trigger wire catheter coaxially around the guide wire catheter and the release mechanism includes trigger wires passing along the annular space between the guide wire catheter and the trigger wire catheter and exiting through apertures in the trigger wire catheter.

The apertures may be equally spaced around the trigger wire catheter.

Preferably the trigger wires are engaged to the graft material by loops of thread-like material and the loops of thread-like material are adapted to remain with the graft material after deployment.

Alternatively the trigger wires may engage directly with the graft material.

Preferably the stent graft prosthesis includes stents of a self expanding type being zig zag Z stents and the tube graft material and the retention is by sutures tied to trigger wires on the deployment device and around bends of the zig zag Z stents on the stent graft prosthesis.

Further retention points may be provided along the length of the stent graft prosthesis such as at the second end of the stent graft prosthesis.

In an alternative form the invention is said to reside in a method of mounting of a stent graft prosthesis to a deployment device for deployment of the stent graft prosthesis in to a curved lumen having an inner side and an outer side of the curve, the method including the step of mounting the stent graft prosthesis to a deployment device so that a first end and a second end of the prosthesis are separately retained to the deployment device, the retention at the first end being by the stent graft prosthesis being retained at a plurality of points of the circumference of the stent graft prosthesis to the deployment device, there being a greater circumferential distance between the two adjacent retention points than

others of the retention points and whereby in use the greater circumferential distance is placed on the inner side of the curve.

Preferably the retention is by fibres such as sutures tied to trigger wires on a deployment device but other forms of retention such as by direct engagement
5 of the trigger wires into fabric of the stent graft is also within the scope of the invention.

The retention is preferably at three points around the circumference of the first end of the stent graft prosthesis.

Preferably the stent graft is a type which includes stents which are zig zag
10 Z stents covered by a graft material.

Preferably the retention is by sutures tied to trigger wires on the deployment device and around bends of the zig zag Z stents on the stent graft.

Preferably the deployment device comprises a guide wire catheter and a trigger wire catheter coaxially around the guide wire catheter with trigger wires
15 passing along the annular space between the guide wire catheter and the trigger wire catheter and exiting through apertures at the retention points. The apertures may be equally spaced around the trigger wire catheter or they may be spaced at other selected spacings.

Further retention points may be provided along the length of the stent
20 graft such as at the distal end of the stent graft.

In a further form the invention is said to reside in a method of deploying a stent graft prosthesis in the thoracic arch of a patient, the thoracic arch having a curvature defining an inner curve and an outer curve, the stent graft prosthesis being mounted on a deployment device under a slidable sheath and being retained
25 to the deployment device at at least a proximal end of the stent graft prosthesis, the proximal retention being provided by retention at a number of points around the circumference of the stent graft prosthesis to provide a plurality of folds between the retention points so that one of the folds of graft material between adjacent retention points is larger than other of the folds, the method of deploying including
30 the steps of deploying the deployment device into the aorta such that the larger of the folds of the graft material is adjacent to the inner curve, withdrawing the sheath

to allow the stent graft prosthesis to expand under the influence of self expanding stents except at the proximal end so that blood flows through the larger fold at the proximal end into the interior of the stent graft Prosthesis, releasing the proximal end of the stent graft Prosthesis thereby allowing the graft to fully expand against the walls of the aorta and withdrawing the deployment device.

It will be seen that by this arrangement blood flow through the larger fold of the proximal end of the graft will cause that side of the graft to engage against the wall of the aorta so that upon subsequent release of the entire stent graft, the stent graft will correctly engage against the walls of the aorta in the thoracic arch.

In a still further form the invention is said to reside in a method of deploying a stent graft Prosthesis in the thoracic arch of a patient, the thoracic arch having a curvature defining an inner curve and an outer curve, the stent graft Prosthesis having a distally extending exposed stent and being mounted on a deployment device under a slidable sheath and being retained to the deployment device at a proximal end of the stent graft Prosthesis and the distally extending exposed stent being retained in a capsule on the deployment device, the proximal retention being provided by retention at a number of points around the circumference of the stent graft prosthesis to provide a plurality of folds between the retention points so that one of the folds of graft material between adjacent retention points is larger than other of the folds, the method of deploying including the steps of deploying the deployment device into the aorta such that the larger of the folds of the graft material is adjacent to the inner curve, withdrawing the sheath to allow the stent graft prosthesis to expand under the influence of self expanding stents except at the proximal end so that blood flows through the larger fold at the proximal end into the interior of the stent graft prosthesis, withdrawing the capsule to release the distally extending exposed stent, releasing the proximal end of the stent graft prosthesis thereby allowing the graft to fully expand against the walls of the aorta and withdrawing the deployment device.

In an alternative form the invention is said to reside in a deployment device for deploying a stent graft prosthesis into a thoracic arch of a patient, the stent graft prosthesis being temporarily mounted to the deployment device and

adapted to be deployed in the thoracic arch, the thoracic arch having a curved lumen having an inner side and an outer side of the curve, the stent graft prosthesis being mounted to the deployment device at least the proximal end of the prosthesis by a retention arrangement, the retention arrangement including a retention to the
5 deployment device at a plurality of points of the circumference of the proximal end of the stent graft prosthesis, there being a greater circumferential distance between two adjacent retention points than other of the points, whereby when the deployment device is deployed in the curved lumen the greater circumferential distance is on the inner side of the curve.

10 In a further alternative form the invention is said to reside in an introducer for introducing a stent graft prosthesis into a curved lumen of a patient, the introducer including an arrangement for temporarily fixing the prosthesis to the introducer while it is being introduced into the lumen, wherein three or more positions on one end of the prosthesis are to be fixed to the arrangement, wherein
15 the circumferential distance between two adjacent ones of those positions is greater than the circumferential distance between other adjacent positions of those positions and wherein the introducer serves to introduce the prosthesis into the lumen with said two adjacent positions next to the inner side of the curve of the lumen.

20 Brief Description of the Drawing

This then generally describes the invention but to assist with understanding, reference will now be made to the accompanying drawings which show preferred embodiments of the invention.

25 FIG. 1 shows a front on view of a stent graft showing where the retention points may be placed in one embodiment of the invention;

FIG. 2 shows the embodiment in FIG. 1 after attachment of the retention points to trigger wires;

FIG. 3 shows a schematic view of a retention arrangement for a stent graft onto a deployment device according to one embodiment of the invention;

30 FIG. 4 shows a detailed transverse part cross section of the embodiment of FIG. 3 in the region of the proximal retention arrangement;

FIG. 5 shows a longitudinal cross section of the embodiment of FIG. 3;
FIGS. 6 to 8 show the various stages of a first embodiment of a stent graft
being deployed into a thoracic arch of a patient; and

FIGS. 9 to 11 show the various stages of a second embodiment of a stent
graft being deployed into the thoracic arch of a patient.

Detailed Description

U.S. Patent No. 5,387,235 entitled "Expandable Transluminal Graft
Prosthesis For Repair Of Aneurysm" discloses apparatus and methods of retaining
grafts onto deployment devices. These features and other features disclosed in
U.S. Patent No. 5,387,235 could be used with the present invention and the
disclosure of U.S. Patent No. 5,387,235 is herewith incorporated in its entirety into
this specification.

U.S. Patent No. 5,720,776 entitled "Barb and Expandable Transluminal
Graft Prosthesis For Repair of Aneurysm" discloses improved barbs with various
forms of mechanical attachment to a stent. These features and other features
disclosed in U.S. Patent No. 5,720,776 could be used with the present invention and
the disclosure of U.S. Patent No. 5,720,776 is herewith incorporated in its entirety
into this specification.

U.S. Patent No. 6,206,931 entitled "Graft Prosthesis Materials" discloses
graft prosthesis materials and a method for implanting, transplanting replacing and
repairing a part of a patient and particularly the manufacture and use of a purified,
collagen based matrix structure removed from a submucosa tissue source. These
features and other features disclosed in U.S. Patent No. 6,206,931 could be used
with the present invention and the disclosure of U.S. Patent No. 6,206,931 is
herewith incorporated in its entirety into this specification.

PCT Patent Publication No. WO 98/53761 entitled "A Prosthesis And A
Method And Means Of Deploying A Prosthesis" discloses an introducer for a
prosthesis which retains the prosthesis so that each end can be moved
independently. These features and other features disclosed in PCT Patent
Publication No. WO 98/53761 could be used with the present invention and the

disclosure of PCT Patent Publication No. WO 98/53761 is herewith incorporated in its entirety into this specification.

5 PCT Patent Publication No. WO 99/29262 entitled "Endoluminal Aortic Stents" discloses a fenestrated prosthesis for placement where there are intersecting arteries. This feature and other features disclosed in PCT Patent Publication No. WO 99/29262 could be used with the present invention and the disclosure of PCT Patent Publication No. WO 99/29262 is herewith incorporated in its entirety into this specification.

10 PCT Patent Publication No. WO 03/034948 entitled "Prosthesis For Curved Lumens" discloses prostheses with arrangements for bending the prosthesis for placement into curved lumens. This feature and other features disclosed in PCT Patent Publication No. WO 03/034948 could be used with the present invention and the disclosure of PCT Patent Publication No. WO 03/034948 is herewith incorporated in its entirety into this specification.

15 U.S. Provisional Patent Application Serial No. 60/392,682, filed June 28, 2002, and U.S. Patent Application Serial No. 10/447,406, filed May 29, 2003, entitled "Trigger Wires" disclose release wire systems for the release of stent grafts retained on introducer devices. This feature and other features disclosed in U.S. Provisional Patent Application Serial No. 60/392,682 and U.S. Patent Application Serial No.
20 10/447,406, filed May 29, 2003 could be used with the present invention and the disclosure of U.S. Provisional Patent Application Serial No. 60/392,682 and U.S. Patent Application Serial No. 10/447,406, filed May 29, 2003 are herewith incorporated in their entirety into this specification.

25 U.S. Provisional Patent Application Serial No. 60/392,667, filed June 28, 2002, and U.S. Patent Application Serial No. 10/609,846, filed June 30, 2003, entitled "Thoracic Deployment Device" disclose introducer devices adapted for deployment of stent grafts particularly in the thoracic arch. This feature and other features disclosed in U.S. Provisional Patent Application Serial No. 60/392,667 and U.S. Patent Application Serial No. 10/609,846, filed June 30, 2003 could be used
30 with the present invention and the disclosure of U.S. Provisional Patent Application

Serial No. 60/392,667 and U.S. Patent Application Serial No. 10/609,846, filed June 30, 2003 are herewith incorporated in their entirety into this specification.

U.S. Provisional Patent Application Serial No. 60/392,599, filed June 28, 2002, and U.S. Patent Application Serial No. 10/609,835, filed June 30, 2003, entitled
5 "Thoracic Aortic Aneurysm Stent Graft" disclose stent grafts that are useful in treating aortic aneurysms particularly in the thoracic arch. This feature and other features disclosed in U.S. Provisional Patent Application Serial No 60/392,599 and U.S. Patent Application Serial No. 10/609,835, filed June 30, 2003 could be used with the present invention, and the disclosure are herewith incorporated in their
10 entirety into this specification.

U.S. Provisional Patent Application Serial No. 60/391,737, filed June 26, 2002, entitled "Stent-Graft Fastening Arrangement" discloses arrangements for fastening stents onto grafts particularly for exposed stents. This feature and other features disclosed in U.S. Provisional Patent Application No. 60/391,737 could be
15 used with the present invention and the disclosure of U.S. Provisional Patent Application Serial No. 60/391,737 is herewith incorporated in its entirety into this specification.

U.S. Provisional Patent Application Serial No. 60/405,367, filed August 23, 2002, entitled "Asymmetric Stent Graft Attachment" discloses retention
20 arrangements for retaining onto and releasing prostheses from introducer devices. This feature and other features disclosed in U.S. Provisional Patent Application Serial No. 60/405,367 could be used with the present invention and the disclosure of U.S. Provisional Patent Application Serial No. 60/405,367 is herewith incorporated in its entirety into this specification.

U.S. Patent Application Serial No. 10/322,862, filed December 18, 2002, entitled "Stent Graft With Improved Adhesion" discloses arrangements on stent
25 grafts for enhancing the adhesion of such stent grafts into walls of vessels in which they are deployed. This feature and other features disclosed in U.S. Patent Application Serial No. 10/322,862 could be used with the present invention and the disclosure of U.S. Patent Application Serial No. 10/322,862 is herewith incorporated
30 in its entirety into this specification.

Now looking more closely at the drawings and in particular FIGS. 1 to 2.

It will be seen from an end on view of the stent graft prosthesis that in its unrestrained state, as particularly shown in FIG. 1, it has a substantially circular body end 1. A deployment device for such a stent graft prosthesis has towards its proximal end a retention arrangement 3 for the retention of the proximal end of the stent graft body end 1 to the deployment device, the mechanism for which will be discussed in detail in relation to FIGS. 3 to 5. The retention arrangement 3 engages various points around the circumference of the stent graft body end 1 to the deployment device to give the asymmetric arrangement as shown in FIG. 2.

To provide the stent graft retention of the present invention, points of the circumference of the graft 1 as shown by the arrows 9 in FIG. 1 are drawn towards the retention arrangement 3 and retained by thread-like material 11 such as fibres or suture material so that the end on view of the stent graft becomes substantially as shown in FIG. 2. In this embodiment there are three retention points but other numbers of retention points may also be used. This asymmetric arrangement of stent graft attachment produces a larger fold 13 and two smaller folds 15. It will be noted, too, that the larger circumferential portion of the proximal end of the graft produces the larger fold 13 and the smaller circumferential portions of the proximal end of the graft produce the smaller folds 15.

One embodiment of a deployment device and stent graft suitable for the stent graft retention of the present invention is shown in FIGS. 3 to 5.

The deployment device 2 in the region of the proximal retention has a guide wire catheter 4 and a trigger wire catheter 8 coaxially around the guide wire catheter 4. Trigger wires 5 pass along the annular space 10 between the guide wire catheter 4 and the trigger wire catheter 8 and exit through apertures 7 at the retention points and then re-enter the annular space 10 between the guide wire catheter 4 and the trigger wire catheter 8 and pass into the nose cone 6. The apertures 7 may be equally spaced around the trigger wire catheter or they may be spaced at other selected spacings. In this embodiment there are three apertures

7 spaced at approximately 120 degrees to each other around the circumference of the trigger wire catheter 8.

5 Where each trigger wire 5 exits out of aperture 7 a thread of suture material or other thread-like material 11 is looped around the trigger wire 5 and is fastened to a bight 14 of the graft material of the stent graft 1 and tied off with a knot 12.

10 As can particularly be seen in Figure 3 the stent graft has zig zag Z stents 17 on its inside for the first two stents from the proximal end and then outside zig zag Z stents 19 distally thereof. Each stent is fastened by sutures 21 to the graft material. Barbs 23 may also be used to encourage retention of the stent grafts against the wall of the aorta. It will be noted that the barbs 23 are distally facing so that pressure of blood flow will cause them to engage more strongly into the wall of the aorta. In some embodiments the thread of suture material or other thread-like material 11 may also be fastened around a portion of the zig zag Z stent 17.

15 Now looking at the embodiment shown in FIGS. 6, 7 and 8 it will be seen that a thoracic arch 30 of an aorta 25 has an outer curve 33 and an inner curve 31. A stent graft is deployed into the thoracic arch to span, for instance, a tear 26 in the wall of the aorta 25 which has caused an aortic dissection 27.

20 A deployment device 32 is inserted into the aorta 25 and bent around the thoracic arch 30. Owing to the curvature of the thoracic arch 30 the deployment device 32 will tend to be nearer the outer curve 33 and hence to ensure good engagement of the stent graft on the inner curve, the stent graft retention of the present invention is used.

25 As can be seen in FIG. 6 the deployment device 32 which is deployed into the thoracic arch 30 has a stent graft prosthesis 34 as shown by the dotted line held within a movable outer sheath 36.

30 In this embodiment the prosthesis 34 does not have a distal retention mechanism associated with the deployment device and hence when the sheath 36 is withdrawn as shown in Figure 7 the stent graft under the influence of its self expanding stents 35 opens except at the proximal end 38 where the graft is retained

- 12 -

to the deployment device 32 by means of the stent graft retention of the present invention.

As can be particularly be seen in FIG. 7 the larger fold 13 of the stent graft is extended towards the inner side of the curve 31 of the thoracic arch 30 and in this position blood flow can flow through the larger fold 13 and cause it to extend
5 against the inner wall 31 before the stent graft fully engages the outer side of the curve 33. At this stage barbs 23, (see FIG. 3) if present, at the proximal end can engage into the inner wall 31 of the aorta and ensure that that portion of the proximal end of the stent graft is retained against the inside wall of the aorta 25.

As shown in FIG. 8 trigger wires have been released (by a mechanism not shown) so that the stent graft retention has been released and the full circumference of the proximal end of the graft has now fully deployed against the walls of the thoracic arch. Hence there is not the danger of a portion of the circumference of the proximal end of the graft, particularly that engaged against the
10 inner curve 31 folding inwards under the influence of pulsating blood flow and closing off the aorta. Other barbs 23, if present at the proximal end, can then engage the wall of the aorta and ensure that that the entire proximal end of the stent graft is retained against the wall of the aorta. It will be noted that in this embodiment the fastenings 11, which are used to retain the stent graft to the trigger
15 wires, remain on the stent graft.

An alternative embodiment of deployment of a stent graft prosthesis retained by the arrangement of the present invention is shown in FIGS. 9, 10 and 11. The stent graft in this embodiment is used to span an aneurysmal sac 29. A number of features are substantially similar to those of Figure 6, 7 and 8 and the
20 same reference numerals are used for corresponding items.

The stent graft prosthesis is similar at the proximal end to that depicted in FIGS. 6 to 8, but at its distal end it has a distally extending exposed zig zag Z stent 42. This distally extending exposed stent 42 may have barbs 47. In this embodiment the deployment device is deployed in the aorta 30 in the same manner
25 as shown in FIG. 6 but subsequent deployment of the stent graft prosthesis occurs in two stages.

In a first stage the sheath 36 is withdrawn, as was shown FIG. 7, but as well as the proximal end 38 being retained by the asymmetric proximal stent graft attachment a capsule 40 retains the exposed stent 42 at the distal end.

5 In the next stage as shown in FIG. 10, the capsule is withdrawn distally so that the exposed stent is released and because of their self expanding nature expand to bear against the walls of the aorta at the distal end of the stent graft prosthesis. The barbs 47 can engage into the wall of the aorta to retain the stent graft in position. At this stage the proximal end 38 of the stent graft prosthesis is still retained to the deployment device by the retention arrangement of the present
10 invention.

It will be noted that the larger fold 13 of the graft is towards the inner side of the curve 31 of the thoracic arch 30 and in this position blood flow can flow through the larger fold 13 and cause it to extend against the inner wall 31 before the graft fully engages the outer side of the curve 33.

15 Then as shown in FIG. 11, in a similar manner to that shown in FIG. 8, the trigger wires can be released (by a mechanism not shown) so that the stent graft prosthesis is released and the full circumference of the proximal end of the graft can fully deploy against the walls of the thoracic arch. Hence there is not the danger of a portion of the circumference of the proximal end of the graft,
20 particularly that engaged against the inner curve 31 folding inwards and closing off the aorta. Other barbs 23, if present at the proximal end, can then engage the wall of the aorta and ensure that that the entire proximal end of the stent graft is retained against the wall of the aorta. It will be noted that in this embodiment the fastenings 11, which are used to retain the stent graft to the trigger wires, remain
25 on the stent graft. The nose cone 44 of the deployment device can then be withdrawn to the capsule 40 and the deployment device withdrawn.

Throughout this specification various indications have been given as to the scope of the invention but the invention is not limited to only one of these but may reside in two or more of these combined together. The examples are given
30 for illustration only and not for limitation.

Claims

1. A stent graft prosthesis mounted to a deployment device and adapted to be deployed in a curved lumen, the curved lumen having an inner side and an outer side of the curve, the stent graft prosthesis being temporarily mounted to the deployment device at at least one end of the prosthesis by a retention arrangement, the retention arrangement including a retention of the stent graft prosthesis to the deployment device at a plurality of points of the circumference of the proximal end of the stent graft prosthesis, there being a greater circumferential distance between two adjacent retention points than other of the points, whereby when the deployment device is deployed in the curved lumen the greater circumferential distance is on the inner side of the curve.
2. A stent graft prosthesis mounted to a deployment device as in Claim 1 wherein the retention arrangement includes a fastening to a release mechanism at at least two points of the circumference of the prosthesis whereby a larger and a smaller fold of the graft material is formed.
3. A stent graft prosthesis mounted to a deployment device as in Claim 1 wherein the retention arrangement includes three retention points so that one larger and two smaller folds of the graft material are formed.
4. A stent graft prosthesis mounted to a deployment device as in Claim 1 wherein the retention arrangement provides one larger lobe and at least one smaller lobe of the proximal end of the graft material wherein the larger lobe is on the inner side of the curve when the deployment device is deployed in the curved lumen.
5. A stent graft prosthesis mounted to a deployment device as in Claim 1 wherein the deployment device includes a guide wire catheter and a trigger wire catheter coaxially around the guide wire catheter with trigger wires passing along the annular space between the guide wire catheter and the trigger wire catheter and exiting through apertures at the retention points and the trigger wires are engaged with the graft material to provide the retention points.
6. A stent graft prosthesis mounted to a deployment device as in Claim 5 wherein the apertures are equally spaced around the trigger wire catheter.

7. A stent graft prosthesis mounted to a deployment device as in Claim 4 wherein the trigger wires are engaged to the graft material by loops of thread-like material.

8. A stent graft prosthesis mounted to a deployment device as in Claim 7
5 wherein the loops of thread-like material are adapted to remain with the graft material after deployment.

9. A deployment device and stent graft prosthesis temporarily mounted thereto and adapted to be deployed in a curved lumen, the curved lumen having an inner side and an outer side of the curve, the deployment device including a
10 deployment catheter and a release mechanism, the stent graft prosthesis comprising a tube of graft material having a first end and a second end and being mounted to the deployment device at at least its first end by a retention arrangement, the retention arrangement including a retention to the deployment device at a plurality of points of the circumference of the proximal end of the stent
15 graft prosthesis, there being a greater circumferential distance between two adjacent retention points than other of the points, and the retention points being provided by the release mechanism being engaged with the graft material, whereby when the deployment device is deployed in the curved lumen the greater circumferential distance is on the inner side of the curve.

10. A stent graft prosthesis mounted to a deployment device as in Claim 9
20 wherein the retention arrangement includes a fastening to a release mechanism at at least two points of the circumference of the prosthesis whereby a larger and a smaller fold of the graft material is formed.

11. A stent graft prosthesis mounted to a deployment device as in Claim 9
25 wherein the retention arrangement includes three retention points so that one larger and two smaller folds of the graft material are formed.

12. A stent graft prosthesis mounted to a deployment device as in Claim 9
30 wherein the retention arrangement provides one larger fold and at least one smaller fold of the proximal end of the graft material wherein the larger fold is on the inner side of the curve when the deployment device is deployed in the curved lumen.

13. A stent graft prosthesis mounted to a deployment device as in Claim 9 wherein the deployment catheter includes a guide wire catheter and a trigger wire catheter coaxially around the guide wire catheter and the release mechanism includes trigger wires passing along the annular space between the guide wire catheter and the trigger wire catheter and exiting through apertures in the trigger wire catheter.

14. A stent graft prosthesis mounted to a deployment device as in Claim 13 wherein the apertures are equally spaced around the trigger wire catheter.

15. A stent graft prosthesis mounted to a deployment device as in Claim 13 wherein the trigger wires are engaged to the graft material by loops of thread-like material.

16. A stent graft prosthesis mounted to a deployment device as in Claim 15 wherein the loops of thread-like material are adapted to remain with the graft material after deployment.

17. A stent graft prosthesis mounted to a deployment device as in Claim 9 wherein the stent graft prosthesis includes stents of self expanding zig zag Z stents and the tube of graft material.

18. A stent graft prosthesis mounted to a deployment device as in Claim 16 wherein the retention is by sutures tied to trigger wires on the deployment device and around bends of the zig zag Z stents on the stent graft.

19. A stent graft prosthesis mounted to a deployment device as in Claim 14 wherein further retention points are provided along the length of the stent graft prosthesis such as at the second end of the stent graft prosthesis.

20. A method of mounting of a stent graft prosthesis to a deployment device for deployment of the stent graft prosthesis in to a curved lumen having an inner side and an outer side of the curve, the method including the step of mounting the stent graft prosthesis to a deployment device so that a first end and a second end of the prosthesis are separately retained to the deployment device, the retention at the first end being by the stent graft prosthesis being retained at a plurality of points of the circumference of the stent graft prosthesis to the deployment device, there being a greater circumferential distance between the two adjacent retention

points than others of the retention points and whereby in use the greater circumferential distance is placed on the inner side of the curve.

21. A method of deploying a stent graft prosthesis in the thoracic arch of a patient, the thoracic arch having a curvature defining an inner curve and an outer curve, the stent graft prosthesis being mounted on a deployment device under a slidable sheath and being retained to the deployment device at at least a proximal end of the stent graft prosthesis, the proximal retention being provided by retention at a number of points around the circumference of the stent graft prosthesis to provide a plurality of folds between the retention points so that one of the folds of graft material between adjacent retention points is larger than other of the folds, the method of deploying including the steps of deploying the deployment device into the aorta such that the larger of the folds of the graft material is adjacent to the inner curve, withdrawing the sheath to allow the stent graft prosthesis to expand under the influence of self expanding stents except at the proximal end so that blood flows through the larger fold at the proximal end into the interior of the stent graft prosthesis, releasing the proximal end of the stent graft prosthesis thereby allowing the graft to fully expand against the walls of the aorta and withdrawing the deployment device.

22. A deployment device for deploying a stent graft prosthesis into a thoracic arch of a patient, the stent graft prosthesis being temporarily mounted to the deployment device and adapted to be deployed in the thoracic arch, the thoracic arch having a curved lumen having an inner side and an outer side of the curve, the stent graft prosthesis being mounted to the deployment device at least the proximal end of the prosthesis by a retention arrangement, the retention arrangement including a retention to the deployment device at a plurality of points of the circumference of the proximal end of the stent graft prosthesis, there being a greater circumferential distance between two adjacent retention points than other of the points, whereby when the deployment device is deployed in the curved lumen the greater circumferential distance is on the inner side of the curve.

23. An introducer for introducing a stent graft prosthesis into a curved lumen of a patient, the introducer including an arrangement for temporarily fixing the prosthesis to the introducer while it is being introduced into the lumen, wherein three or more positions on one end of the prosthesis are to be fixed to the arrangement, wherein the circumferential distance between two adjacent ones of those positions is greater than the circumferential distance between other adjacent positions of those positions and wherein the introducer serves to introduce the prosthesis into the lumen with said two adjacent positions next to the inner side of the curve of the lumen.

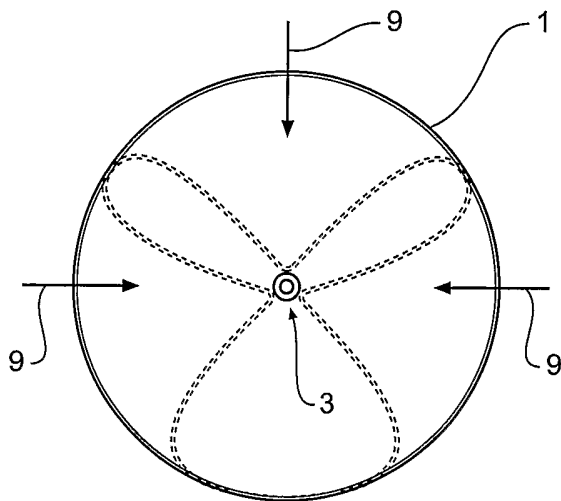

Fig 1

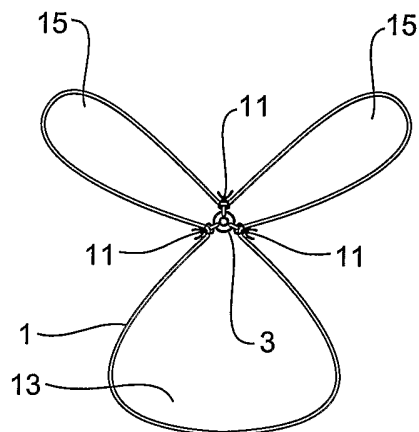

Fig 2

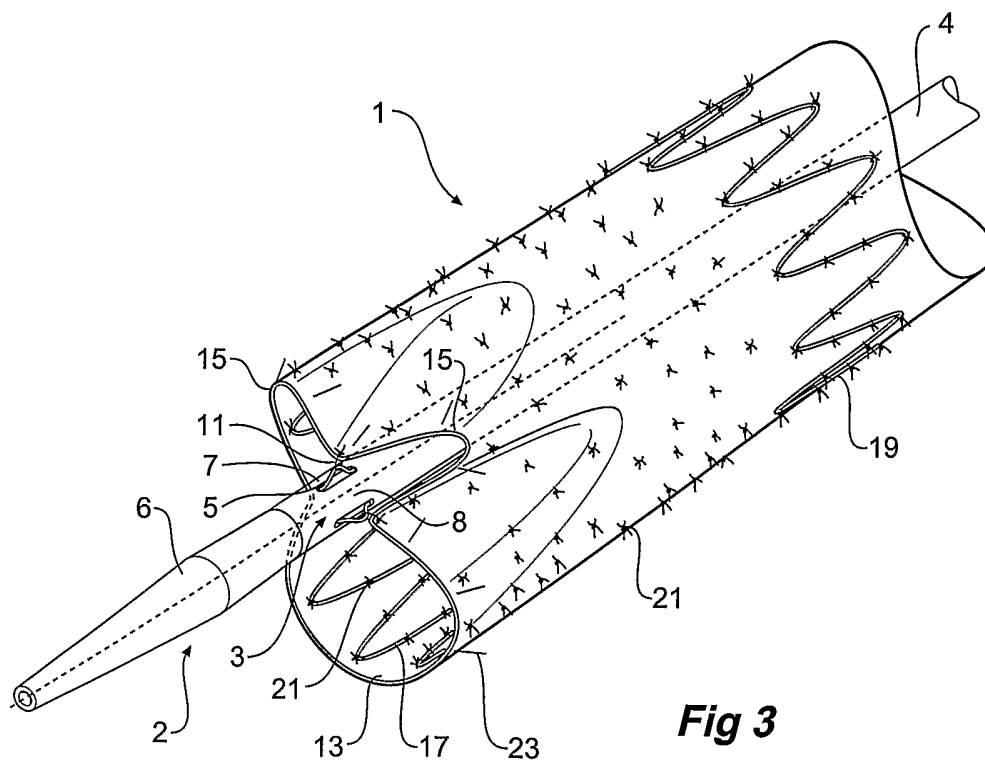

Fig 3

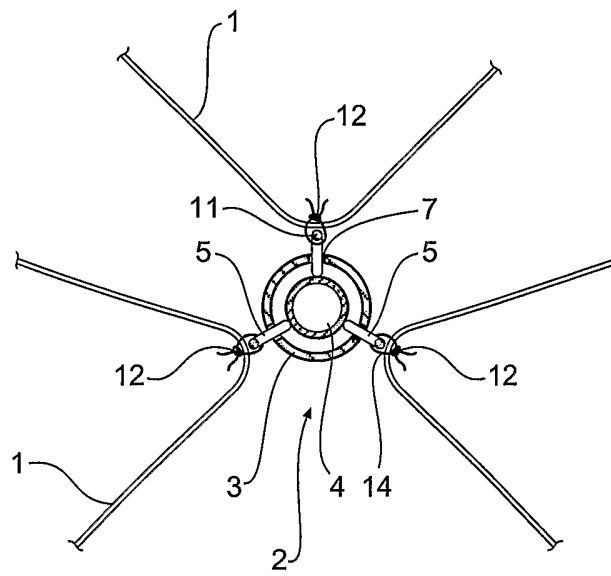

Fig 4

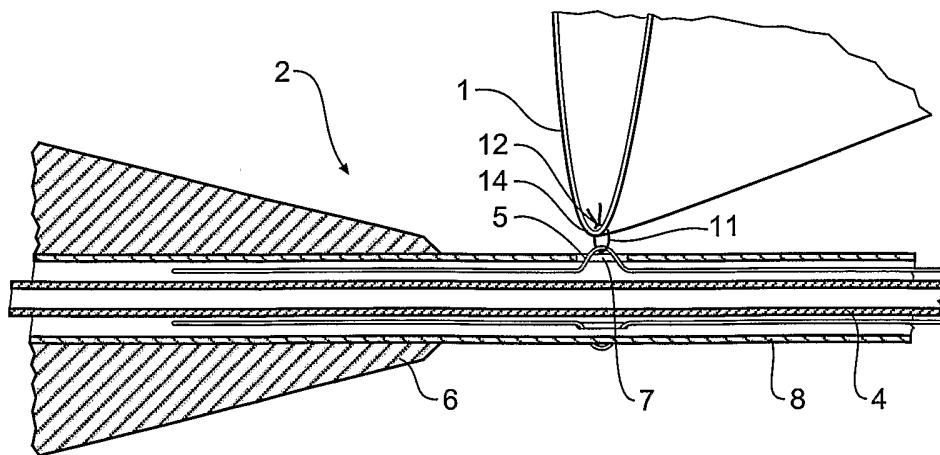
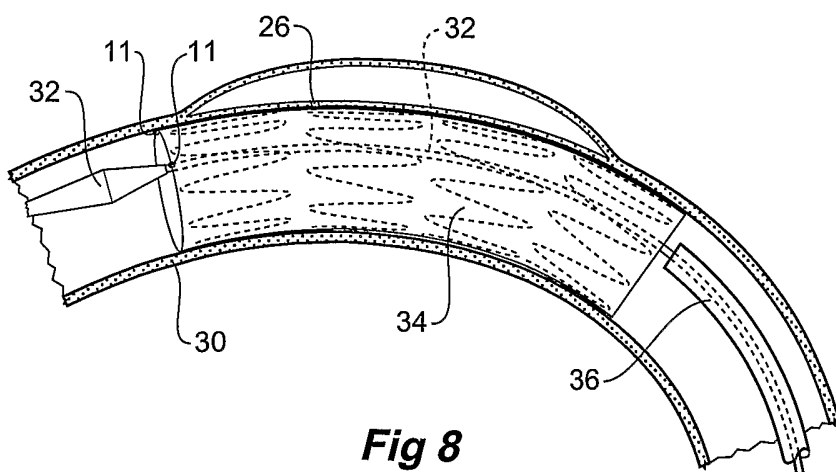
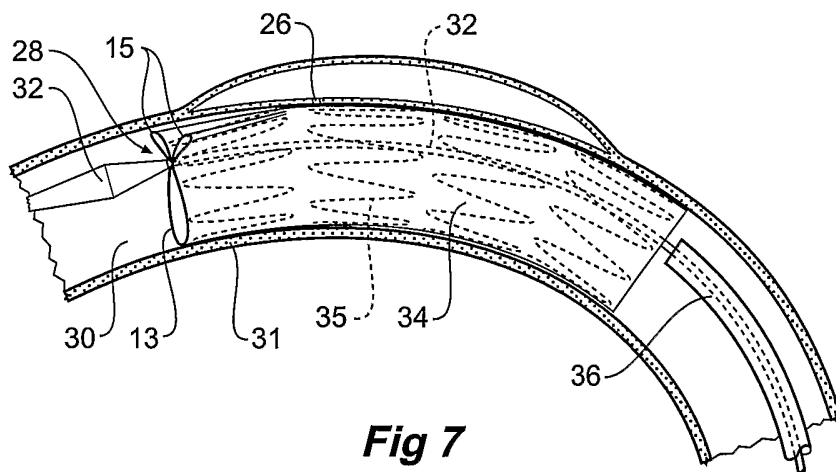
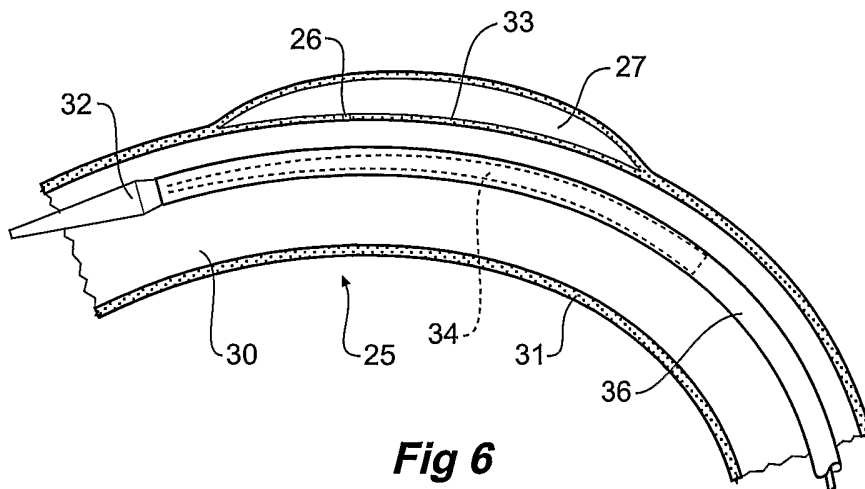

Fig 5



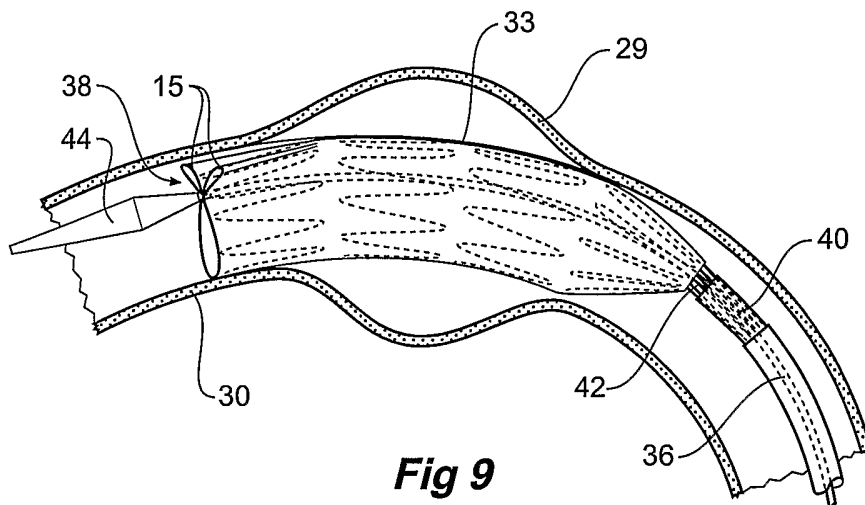

Fig 9

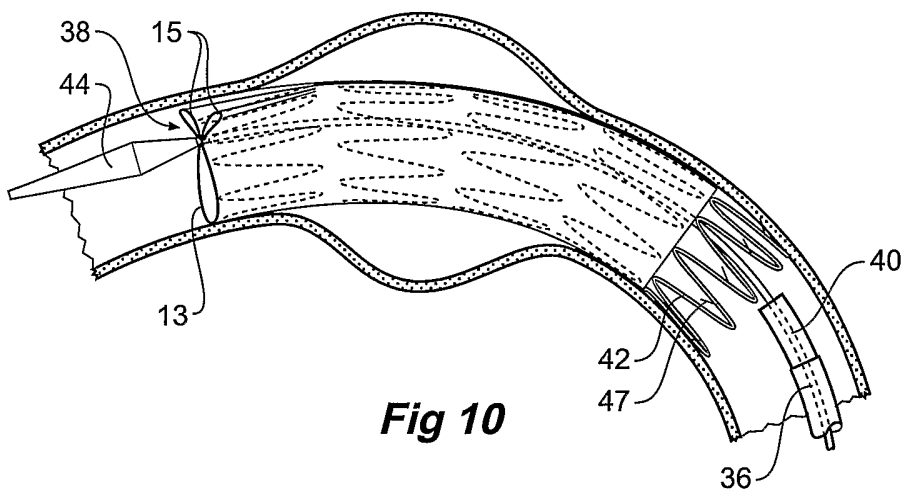

Fig 10

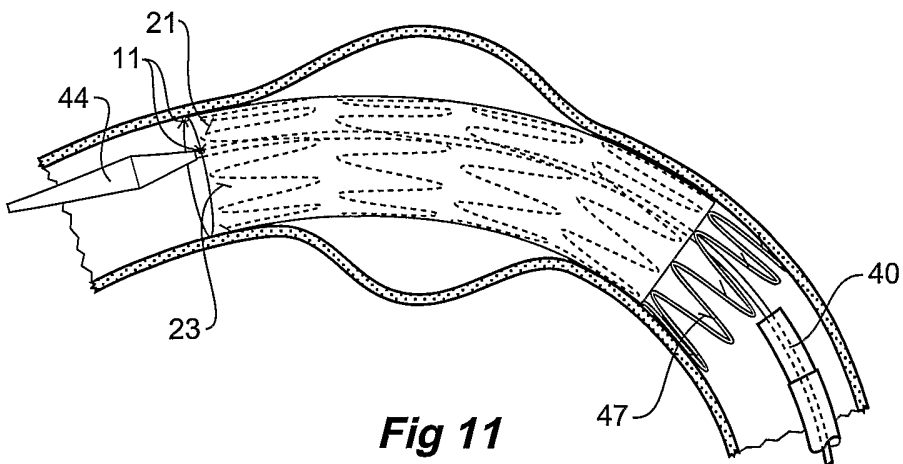

Fig 11

INTERNATIONAL SEARCH REPORT

International Application No

PCT/US 03/26561

A. CLASSIFICATION OF SUBJECT MATTER
IPC 7 A61F2/06

According to International Patent Classification (IPC) or to both national classification and IPC

B. FIELDS SEARCHED

Minimum documentation searched (classification system followed by classification symbols)

IPC 7 A61F

Documentation searched other than minimum documentation to the extent that such documents are included in the fields searched

Electronic data base consulted during the international search (name of data base and, where practical, search terms used)

EPO-Internal

C. DOCUMENTS CONSIDERED TO BE RELEVANT

Category *	Citation of document, with indication, where appropriate, of the relevant passages	Relevant to claim No.
A	EP 0 680 733 A (INOUE KANJI) 8 November 1995 (1995-11-08) column 21, line 6 - line 17 figures 28,29 -----	1-20, 22, 23
A	WO 95 26695 A (MARONEY CHARLES T ;MCCULLOUGH KIMBERLY A (US); LAU LILIP (US); RHE) 12 October 1995 (1995-10-12) figures 33A-33E, 35A-35C, 36A-36C, 39, 40 page 67, line 2 - page 70, line 15 -----	1-20, 22, 23

Further documents are listed in the continuation of box C.

Patent family members are listed in annex.

* Special categories of cited documents :

"A" document defining the general state of the art which is not considered to be of particular relevance

"E" earlier document but published on or after the international filing date

"L" document which may throw doubts on priority claim(s) or which is cited to establish the publication date of another citation or other special reason (as specified)

"O" document referring to an oral disclosure, use, exhibition or other means

"P" document published prior to the international filing date but later than the priority date claimed

"T" later document published after the international filing date or priority date and not in conflict with the application but cited to understand the principle or theory underlying the invention

"X" document of particular relevance; the claimed invention cannot be considered novel or cannot be considered to involve an inventive step when the document is taken alone

"Y" document of particular relevance; the claimed invention cannot be considered to involve an inventive step when the document is combined with one or more other such documents, such combination being obvious to a person skilled in the art.

"&" document member of the same patent family

Date of the actual completion of the international search

2 December 2003

Date of mailing of the international search report

10/12/2003

Name and mailing address of the ISA

European Patent Office, P.B. 5818 Patentlaan 2
NL - 2280 HV Rijswijk
Tel. (+31-70) 340-2040, Tx. 31 651 epo nl,
Fax: (+31-70) 340-3016

Authorized officer

Skorovs, P

INTERNATIONAL SEARCH REPORT

International application No.
PCT/US 03/26561

Box I Observations where certain claims were found unsearchable (Continuation of item 1 of first sheet)

This International Search Report has not been established in respect of certain claims under Article 17(2)(a) for the following reasons:

1. Claims Nos.: 21
because they relate to subject matter not required to be searched by this Authority, namely:
Rule 39.1(iv) PCT - Method for treatment of the human or animal body by surgery
2. Claims Nos.:
because they relate to parts of the International Application that do not comply with the prescribed requirements to such an extent that no meaningful International Search can be carried out, specifically:
3. Claims Nos.:
because they are dependent claims and are not drafted in accordance with the second and third sentences of Rule 6.4(a).

Box II Observations where unity of invention is lacking (Continuation of item 2 of first sheet)

This International Searching Authority found multiple inventions in this international application, as follows:

1. As all required additional search fees were timely paid by the applicant, this International Search Report covers all searchable claims.
2. As all searchable claims could be searched without effort justifying an additional fee, this Authority did not invite payment of any additional fee.
3. As only some of the required additional search fees were timely paid by the applicant, this International Search Report covers only those claims for which fees were paid, specifically claims Nos.:
4. No required additional search fees were timely paid by the applicant. Consequently, this International Search Report is restricted to the invention first mentioned in the claims; it is covered by claims Nos.:

Remark on Protest

- The additional search fees were accompanied by the applicant's protest.
- No protest accompanied the payment of additional search fees.

INTERNATIONAL SEARCH REPORT

Information on patent family members

International Application No

PCT/US 03/26561

Patent document cited in search report	Publication date	Patent family member(s)	Publication date	
EP 0680733	A	08-11-1995	WO 9505788 A1	02-03-1995
			US 5976179 A	02-11-1999
			DE 69332644 D1	20-02-2003
			DE 69332644 T2	25-09-2003
			EP 1010405 A2	21-06-2000
			EP 0680733 A1	08-11-1995
			EP 0958795 A2	24-11-1999
			JP 3130047 B2	31-01-2001
			US 6364901 B1	02-04-2002
			US 2002198586 A1	26-12-2002
			WO 9526695	A
US 6165210 A	26-12-2000			
AT 252872 T	15-11-2003			
AT 244543 T	15-07-2003			
AU 690684 B2	30-04-1998			
AU 2379595 A	23-10-1995			
CA 2157575 A1	12-10-1995			
CA 2261941 A1	12-10-1995			
DE 69531239 D1	14-08-2003			
EP 0997115 A2	03-05-2000			
EP 0754016 A1	22-01-1997			
JP 3129327 B2	29-01-2001			
JP 8509899 T	22-10-1996			
WO 9526695 A2	12-10-1995			
AU 4757596 A	31-07-1996			
WO 9621404 A1	18-07-1996			
US 2003208260 A1	06-11-2003			
US 6015429 A	18-01-2000			
US 5919225 A	06-07-1999			
US 2002040236 A1	04-04-2002			
US 5873906 A	23-02-1999			
US 6001123 A	14-12-1999			
US 2002156523 A1	24-10-2002			
US 2003055484 A1	20-03-2003			
US 6331188 B1	18-12-2001			
US 6517570 B1	11-02-2003			
US 6017362 A	25-01-2000			