



(11) **EP 3 316 411 B1**

(12) **EUROPEAN PATENT SPECIFICATION**

(45) Date of publication and mention of the grant of the patent:
03.04.2024 Bulletin 2024/14

(51) International Patent Classification (IPC):
H01R 13/436^(2006.01) H01R 43/26^(2006.01)

(21) Application number: **17207739.8**

(52) Cooperative Patent Classification (CPC):
H01R 13/4362; H01R 43/26

(22) Date of filing: **15.12.2017**

(54) **ELECTRICAL CONNECTOR APPARATUS HAVING A MALE HOUSING AND A FEMALE HOUSING WITH RIBS**

ELEKTRISCHE VERBINDERVORRICHTUNG MIT EINEM MÄNNLICHEN GEHÄUSE UND EINEM WEIBLICHEN GEHÄUSE MIT RIPPEN UND MONTAGEMETHODE

APPAREIL CONNECTEUR ÉLECTRIQUE COMPORTANT UN BOÎTIER MÂLE ET UN BOÎTIER FEMELLE À NERVURES ET MÉTHODE D' ASSEMBLAGE

(84) Designated Contracting States:
AL AT BE BG CH CY CZ DE DK EE ES FI FR GB GR HR HU IE IS IT LI LT LU LV MC MK MT NL NO PL PT RO RS SE SI SK SM TR

- **Abraham, Rajit**
Farmington Hills, Michigan 48335 (US)
- **Jabrane, Khalid**
Farmington Hills, Michigan 48335 (US)

(30) Priority: **13.01.2017 US 201715405654**

(74) Representative: **Latscha Schöllhorn Partner AG**
Grellingerstrasse 60
4052 Basel (CH)

(43) Date of publication of application:
02.05.2018 Bulletin 2018/18

(73) Proprietor: **J.S.T. Corporation**
Farmington Hills, MI 48335 (US)

(56) References cited:
US-A- 5 830 013 US-A- 6 135 802
US-A1- 2017 179 643 US-A1- 2017 207 577
US-B1- 7 278 890

(72) Inventors:

- **Holub, Franklin A.**
Farmington Hills, Michigan 48335 (US)

EP 3 316 411 B1

Note: Within nine months of the publication of the mention of the grant of the European patent in the European Patent Bulletin, any person may give notice to the European Patent Office of opposition to that patent, in accordance with the Implementing Regulations. Notice of opposition shall not be deemed to have been filed until the opposition fee has been paid. (Art. 99(1) European Patent Convention).

Description**BACKGROUND OF THE INVENTION**

[0001] The present invention generally relates to an electrical connector apparatus with a male housing and a female housing having a terminal position assurance device (TPA). More particularly, the invention is directed to ribs and other protective features provided on the male housing and the female housing to prevent the TPA from moving from a pre-set position to a final lock position. US 6,135,802 A and US 5,830,013 A describe variants of connectors.

SUMMARY OF THE INVENTION

[0002] The present invention relates to a female housing of an electrical connector apparatus according to claim 1, a male housing of an electrical connector apparatus according to claim 2, an electrical connector apparatus according to claim 3 and to a method for assembling an electrical connector apparatus according to claim 4.

[0003] At least a terminal is provided into each of the male housing and the female housing, when each of their respective TPA is at a pre-set position. The set of terminals provided for the male housing is secured thereto when the TPA thereof is placed at the final lock position. Similarly, the set of terminals provided for the female housing is secured thereto when the TPA of the female housing is placed at the final lock position. Thereafter, the male housing and the female housing may be engaged together.

[0004] To ensure that the TPA provided in the male housing and the TPA provided in the female housing of the electrical connector apparatus is not moved from a pre-set position to a final lock position during shipping and/or handling, the male housing and the female housing are provided with ribs to protect the TPA from physical contact. These ribs create a physical protective barrier to prevent the TPA from being moved from the pre-set position to the final lock position.

[0005] The electrical connector apparatus of the present invention is assembled and packaged in bags in bulk and shipped with the TPA in the pre-set position. This way, the operator can insert terminals into the electrical connector apparatus immediately upon receiving the electrical connector apparatus.

[0006] However, since the electrical connector apparatus is packaged and shipped in bulk, various parts can make contact with the TPA during shipping and/or handling which can cause an unprotected TPA from being moved from the pre-set position to the final lock position. If this occurs, the operator of the electrical connector apparatus will have to reset the TPA from the final position to the pre-set position in order to insert the terminals. This causes an inconvenience to the operator as well as wastes time when inserting the terminals into the electrical connector apparatus.

[0007] Additional features, advantages, and embodiments of the invention are set forth apparent from consideration of the following detailed description, drawings, and claims. Moreover, it is to be understood that both the foregoing summary of the invention and the following detailed description are exemplary and intended to provide further explanations without limiting the scope of the invention as claimed.

BRIEF DESCRIPTION OF THE DRAWINGS

[0008]

FIG. 1 is an exploded perspective view of the electrical connector apparatus of the present invention including the male housing, the female housing, and the TPA.

FIG. 2A is a cross-sectional view of the first embodiment of the present invention showing the male housing of the electrical connector apparatus with the TPA in the pre-set position.

FIG. 2B is a cross-sectional view of the first embodiment of the present invention showing the male housing of the electrical connector apparatus with the TPA in the final lock position.

FIG. 3A is a cross-sectional view of the first embodiment of the present invention showing the female housing of the electrical connector apparatus with the TPA in the pre-set position.

FIG. 3B is a cross-sectional view of the first embodiment of the present invention showing the female housing of the electrical connector apparatus with the TPA in the final lock position.

FIG. 4A is a perspective view of first embodiment of the present invention showing the female housing of the electrical connector apparatus with the TPA in the pre-set position.

FIG. 4B is a perspective view of first embodiment of the present invention showing the female housing of the electrical connector apparatus with the TPA in the final lock position.

FIG. 5A is a perspective view of the first embodiment of the present invention showing the male housing of the electrical connector apparatus with the TPA in the pre-set position.

FIG. 5B is a perspective view of the first embodiment of the present invention showing the male housing of the electrical connector apparatus with the TPA in the final lock position.

FIG. 6 is an exploded perspective view of the second embodiment of the present invention showing the electrical connector assembling including the male housing, the female housing, and the TPA.

FIG. 7 is a perspective view of the second embodiment of the present invention showing the male housing of the electrical connector with the TPA in the pre-set position.

FIG. 8A is a perspective view of the second embodiment of the present invention showing the male housing and the TPA of the electrical connector apparatus.

FIG. 8B is a perspective view of the second embodiment of the present invention showing the male housing of the electrical connector with the TPA in the pre-set position.

FIG. 9A is a cross-sectional view of the second embodiment of the present invention showing the female housing of the electrical connector apparatus with the TPA in the pre-set position.

FIG. 9B is a cross-sectional view of the second embodiment of the present invention showing the female housing of the electrical connector apparatus with the TPA in the final lock position.

FIG. 10A is a cross-sectional view of the second embodiment of the present invention showing the male housing of the electrical connector apparatus with the TPA in the pre-set position.

FIG. 10B is a cross-sectional view of the second embodiment of the present invention showing the male housing of the electrical connector apparatus with the TPA in the final lock position.

FIG. 11A is a perspective view of the second embodiment of the present invention showing the female housing of the electrical connector apparatus with the TPA in the pre-set position.

FIG. 11B is a perspective view of the second embodiment of the present invention showing the female housing of the electrical connector apparatus with the TPA in the final lock position.

DETAILED DESCRIPTION OF THE PREFERRED EMBODIMENTS

[0009] FIG. 1 is an exploded view showing the electrical connector apparatus of the present invention, generally referred to as reference number 1. The electrical connector apparatus 1 includes a male housing 2 and a female housing 3. TPA 4 is provided in the male housing

2 and TPA 5 is provided in the female housing 3. Additionally, FIG. 1 shows ribs 6, 7, 8, 9, 10, and 11 of the male housing 2.

[0010] Ribs 6, 7, 8, 9, 10, and 11 are provided on the male housing 2 in order to protect the TPA 4 from any physical contact. Therefore, when the TPA 4 is set in the pre-set position during shipping, the ribs 6, 7, 8, 9, 10, and 11 will prevent the TPA 4 from moving to the final lock position. Furthermore, the ribs 6, 7, 8, 9, 10, and 11 are located on the periphery of the TPA 4 so as to protect the TPA 4 from all sides.

[0011] Furthermore, as can be seen in Figure 1, the male housing has a set of terminal apertures for receiving therein a set of other terminals. The male housing also comprises an opening for receiving the female housing.

[0012] FIG. 2A depicts a cross-sectional view of the male housing 2 in which the TPA 4 is in the pre-set position. This is the position in which the male housing 2 of the electrical connector apparatus 1 is shipped. FIG 2B shows a cross-sectional view of the male housing 2 in which the TPA 4 is in the final lock position. This final lock position makes inserting the terminals into the electrical connector apparatus more difficult for the operator; therefore, it is preferable that the TPA 4 is not moved to the final lock position during shipping.

[0013] FIG. 3A illustrates a cross-sectional view of the female housing 3 with the TPA 5 in the pre-set position. Similar to the male housing 2, this is the position in which the female housing 3 of the electrical connector apparatus 1 is shipped. FIG. 3B shows a cross-sectional view of the female housing 3 in which the TPA 5 is in the final lock position. As explained above, it is preferable that the TPA 5 is not moved to this final lock position during shipping and/or handling.

[0014] FIG. 4A illustrates a perspective view of the female housing 3 of the electrical connector apparatus 1 showing the TPA 5 in the pre-set position. TPA 5 is located on the bottom, or underneath, of the female housing 3 in a bottom slot. Additionally, the female housing has a set of terminal apertures for receiving therein at least a set of terminals.

[0015] FIG. 4A further shows ribs 12, 13, 14, 15, 16, 17, and 18 that are provided on the bottom side of the female housing 3 and that surround the TPA 5 so as to prevent the TPA 5 from being physically pressed down into the final lock position during shipping, handling, or at any other time prior to reaching the operator. The ribs 12, 13, 14, 15, 16, 17, and 18 are located on the periphery of the TPA 5 so as to protect the TPA 5 from all sides.

FIG 4B shows the female housing 3 of the electrical connector apparatus 1 once the TPA 5 has been moved to the final lock position.

[0016] FIG. 5A illustrates a perspective view of the male housing 2 of the electrical connector apparatus 1 showing the TPA 4 in the pre-set position. As can be seen in FIG. 5A, when the TPA 4 is in the pre-set position, during shipping or at any other time, the TPA 4 is protected by the ribs 6, 7, 8, 9, 10, and 11 from all sides.

These ribs 6, 7, 8, 9, 10, and 11 are located on the periphery of the TPA 4 so as to protect the TPA 4 from being pressed down into the final lock position. A perspective view of the male housing with the TPA 4 pressed down into the final lock position is shown in FIG. 5B.

[0017] FIG. 6, FIG. 7, FIG. 8A, FIG. 8B, FIG. 9A, FIG. 9B, FIG. 10A, FIG. 10B, FIG. 11A and FIG. 11B illustrate an electrical connector apparatus according to the second embodiment of the present invention. Specifically, the second embodiment of the present invention includes electrical connector apparatus 100, TPA 104, and TPA 105 having 16 pins. However, the present invention is not limited to any specific number of pins for the electrical connector apparatus or TPA.

[0018] In the second embodiment of the present invention, the male housing, the female housing, the TPA, and the ribs operate identically to the first embodiment, as detailed above.

[0019] Specifically, Figure 6 illustrates an exploded perspective view of the electrical connector apparatus 100 according to the second embodiment of the present invention. Electrical connector apparatus 100 includes male housing 102, TPA 104, female housing 103, and TPA 105. Furthermore, Figure 6 shows the ribs 106, 107, 108, 109, 110, and 111 provided on the male housing 102 to protect the TPA 104.

[0020] Figure 7 is a perspective view depicting the male housing 102 of the electrical connector apparatus 100 with the TPA 104 in the pre-set position. Ribs 106, 107, 108, 109, 110, and 111 are provided on the male housing 102 so as to surround the TPA 104 along the periphery of the TPA 104. Ribs 106, 107, 108, 109, 110, and 111 protect the TPA 104 so that the TPA 104 is not moved from a pre-set position to a final lock position during shipping and/or handling.

[0021] Figure 8A illustrates a perspective view of the male housing 102 of the electrical connector apparatus 100 with the TPA 104 removed in order to fully see the placement of the TPA 104 in the male housing 102. Figure 8B shows the male housing 102 once the TPA 104 has been inserted into the male housing 102 and set in the pre-set position.

[0022] The female housing 103 is also provided with ribs 112, 113, 114, 115, 116, 117, and 118 to protect the TPA 103 from being moved from a pre-set position, as shown in Figure 11A, to the final lock position, as shown in Figure 11B. These ribs 112, 113, 114, 115, 116, 117, and 118 are located on the periphery of the TPA 103 so as to create a physical barrier to protect the TPA 103 from all sides.

[0023] As can be seen in Figures 9A and 9B, the TPA 105 of the female housing 103 can be in either a pre-set position or a final lock position. Similarly, the TPA 104 of the male housing 102 can be in either a pre-set position, as shown in Figure 10A, or a final lock position, as shown in Figure 10B.

Claims

1. A female housing (3; 103) of an electrical connector apparatus (1; 100), comprising:

a set of terminal apertures for receiving therein at least a set of terminals;
 a bottom slot located underneath the female housing (3; 103); and
 a first terminal position assurance device (5; 105) (TPA) accommodated within the bottom slot,
characterised in that the female housing further comprises:

ribs (12, 13, 14, 15, 16, 17, 18; 112, 113, 114, 115, 116, 117, 118) provided on the female housing (3; 103) along a periphery of the TPA (5; 105) to protect the TPA (5; 105) from physical contact, wherein the first TPA (5; 105) includes at each of its width-wise outer sides two rib-shaped engagement members extending therefrom for allowing the first TPA (5; 105) to be at a pre-set position during transport of the female housing (3; 103) and at a final lock position for engaging the set of terminals.

2. A male housing (2; 102) of an electrical connector apparatus (1; 100), comprising:

a set of terminal apertures for receiving therein a set of other terminals;
 a second terminal position assurance device (4; 104) (TPA);
 an opening for receiving the second TPA (4; 104);
 a first end having the set of terminal apertures for receiving therein the set of other terminals; wherein the male housing (2; 102) is configured to receive the female housing (3; 103) into a second end of the male housing (2; 102),
characterised in that
 the male housing further comprises:

ribs (6, 7, 8, 9, 10, 11; 106, 107, 108, 109, 110, 111) provided on the male housing (2; 102) along a periphery of the second TPA (4; 104) to protect the second TPA (4; 104) from physical contact, wherein the male housing (2; 102) is configured to receive the female housing (3; 103) into a second end of the male housing (2; 102), wherein the second TPA (4; 104) includes at each of its width-wise outer sides two rib-shaped engagement members extending therefrom for allowing the second TPA (4; 104) to be at a

pre-set position during transport of the male housing (2; 102) and at a final lock position for engaging the set of other terminals.

3. An electrical connector apparatus (1; 100), comprising: 5

a female housing (3; 103) according to claim 1, and
 a male housing (2; 102) according to claim 2, 10
characterized in that the ribs (6, 7, 8, 9, 10, 11; 106, 107, 108, 109, 110, 111) on the male housing (2; 102) are configured to extend beyond the second TPA, when the second TPA is at a pre-set position, to protect the second TPA (4; 104) 15
 from physical contact.

4. A method for assembling an electrical connector apparatus (1; 100), comprising the steps of: 20

providing a female housing (3; 103) according to claim 1;
 accommodating a first terminal position assurance device (5; 105) (TPA) within a bottom slot located underneath the female housing (3; 103); 25
 providing a male housing (2; 102) according to claim 2;
 accommodating a second terminal position assurance device (4; 104) (TPA) within an opening of the male housing (2; 102); 30
 accommodating the female housing (3; 103) into the male housing (2; 102); wherein the step of accommodating the first TPA (5; 105) within the bottom slot located underneath the female housing (3; 103) further comprises the step of providing the first TPA (5; 105) at each of its widthwise outer sides with two rib-shaped engagement members extending therefrom for allowing the first TPA (5; 105) to be at a pre-set position during transport of the female housing (3; 103) and to be at a final lock position for engaging the set of terminals; and wherein 35
 the step of accommodating the second TPA (4; 104) within the opening of the male housing (2; 102) further comprises the step of providing the second TPA (4; 104) at each of its widthwise outer sides with two rib-shaped engagement members extending therefrom for allowing the second TPA (4; 104) device to be at a pre-set position during transport of the male housing (2; 102) and at a final lock position for engaging the set of terminals. 40
 45
 50

Patentansprüche 55

1. Buchsengehäuse (3; 103) einer elektrischen Verbindereinrichtung (1; 100), umfassend:

einen Satz von Anschlussaperturen zum Aufnehmen mindestens eines Satzes von Anschlüssen darin;

einen unteren Schlitz, der sich unterhalb des Buchsengehäuses (3; 103) befindet; und eine erste Anschlusspositionssicherungsvorrichtung (5; 105) (TPA), die innerhalb des unteren Schlitzes untergebracht ist,

dadurch gekennzeichnet, dass das Buchsengehäuse ferner umfasst: Rippen (12, 13, 14, 15, 16, 17, 18; 112, 113, 114, 115, 116, 117, 118), die an dem Buchsengehäuse (3; 103) entlang eines Umfangs der TPA (5; 105) bereitgestellt sind, um die TPA (5; 105) vor physischem Kontakt zu schützen, wobei die erste TPA (5; 105) an jeder ihrer Außenseiten der Breite nach zwei rippenförmige Eingriffselemente einschließt, die sich davon erstrecken, um zu Ermöglichen, dass die erste TPA (5; 105) während des Transports des Buchsengehäuses (3; 103) in einer voreingestellten Position und in einer endgültigen Verriegelungsposition zum Ineingriffnehmen des Satzes von Anschlüssen ist.

2. Steckergehäuse (2; 102) einer elektrischen Verbindereinrichtung (1; 100), umfassend:

einen Satz von Anschlussaperturen zum Aufnehmen eines Satzes von anderen Anschlüssen darin;

eine zweite Anschlusspositionssicherungsvorrichtung (4; 104) (TPA);

eine Öffnung zum Aufnehmen der zweiten TPA (4; 104);

ein erstes Ende, das den Satz von Anschlussaperturen zum Aufnehmen eines Satzes von anderen Anschlüssen darin aufweist;

wobei das Steckergehäuse (2; 102) konfiguriert ist, um das Buchsengehäuse (3; 103) in einem zweiten Ende des Steckergehäuses (2; 102) aufzunehmen, **dadurch gekennzeichnet, dass** das Steckergehäuse ferner umfasst: Rippen (6, 7, 8, 9, 10, 11; 106, 107, 108, 109, 110, 111), die an dem Steckergehäuse (2; 102) entlang eines Umfangs der zweiten TPA (4; 104) bereitgestellt sind, um die zweite TPA (4; 104) vor physischem Kontakt zu schützen, 40
 wobei das Steckergehäuse (2; 102) konfiguriert ist, um das Buchsengehäuse (3; 103) in ein zweites Ende des Steckergehäuses (2; 102) aufzunehmen, wobei die zweite TPA (4; 104) an jeder ihrer Außenseiten der Breite nach zwei rippenförmige Eingriffselemente einschließt, die sich davon erstrecken, zum Ermöglichen, dass die zweite TPA (4; 104) während des Transports des Steckergehäuses (2; 102) in einer voreingestellten Position und in einer endgültigen Verriegelungsposition zum Ineingriffnehmen des 45
 50

Satzes von anderen Anschlüssen ist.

3. Elektrische Verbindereinrichtung (1; 100), umfassend:

ein Buchsengehäuse (3; 103) nach Anspruch 1 und ein Steckergehäuse (2; 102) nach Anspruch 2, **dadurch gekennzeichnet, dass** die Rippen (6, 7, 8, 9, 10, 11; 106, 107, 108, 109, 110, 111) an dem Steckergehäuse (2; 102) konfiguriert sind, um sich über die zweite TPA hinaus zu erstrecken, wenn die zweite TPA in einer voreingestellten Position ist, um die zweite TPA (4; 104) vor physischem Kontakt zu schützen.

4. Verfahren zum Zusammenbauen einer elektrischen Verbindereinrichtung (1; 100), umfassend die Schritte:

Bereitstellen eines Buchsengehäuses (3; 103) nach Anspruch 1;
 Unterbringen einer ersten Anschlusspositionssicherungsvorrichtung (5; 105) (TPA) innerhalb eines unteren Schlitzes, der sich unterhalb des Buchsengehäuses (3; 103) befindet;
 Bereitstellen eines Steckergehäuses (2; 102) nach Anspruch 2;
 Unterbringen einer zweiten Anschlusspositionssicherungsvorrichtung (4; 104) (TPA) innerhalb einer Öffnung des Steckergehäuses (2; 102);
 Unterbringen des Buchsengehäuses (3; 103) in dem Steckergehäuse (2; 102); wobei der Schritt des Unterbringens der ersten TPA (5; 105) innerhalb des unteren Schlitzes, der sich unterhalb des Buchsengehäuses (3; 103) befindet, ferner den Schritt eines Versehens der ersten TPA (5; 105) an jeder ihrer Außenseiten der Breite nach mit zwei rippenförmigen Eingriffselementen umfasst, die sich davon erstrecken, zum Ermöglichen, dass die erste TPA (5; 105) während des Transports des Buchsengehäuses (3; 103) in einer voreingestellten Position und in einer endgültigen Verriegelungsposition zum Ineingriffnehmen des Satzes von Anschlüssen ist; und wobei der Schritt des Unterbringens der zweiten TPA (4; 104) innerhalb der Öffnung des Steckergehäuses (2; 102) ferner den Schritt des Versehens der zweiten TPA (4; 104) an jeder ihrer Außenseiten der Breite nach mit zwei rippenförmigen Eingriffselementen umfasst, die sich davon erstrecken, zum Ermöglichen, dass die zweite TPA (4; 104) in einer voreingestellten Position während des Transports des Steckergehäuses (2; 102) und in einer endgültigen Verriegelungsposition zum Ineingriffnehmen des Satzes von Anschlüssen ist.

Revendications

1. Logement femelle (3 ; 103) d'un appareil de connecteur électrique (1 ; 100), comprenant :

5

un ensemble d'ouvertures de bornes pour recevoir en son sein au moins un ensemble de bornes ;
 une fente inférieure située en dessous du logement femelle (3 ; 103) ; et
 un premier dispositif de maintien de position de borne (5 ; 105) (TPA) reçu à l'intérieur de la fente inférieure,

10

15

caractérisé en ce que le logement femelle comprend en outre : des nervures (12, 13, 14, 15, 16, 17, 18 ; 112, 113, 114, 115, 116, 117, 118) prévues sur le logement femelle (3 ; 103) le long d'une périphérie du TPA (5 ; 105) pour protéger le TPA (5 ; 105) d'un contact physique, dans lequel le premier TPA (5 ; 105) comporte, au niveau de chacun de ses côtés externes dans le sens de la largeur, deux éléments de mise en prise en forme de nervure s'étendant à partir de celui-ci pour permettre au premier TPA (5 ; 105) d'être à une position prédéfinie pendant le transport du logement femelle (3 ; 103) et à une position de verrouillage finale pour venir en prise avec l'ensemble de bornes.

20

25

30

2. Logement mâle (2 ; 102) d'un appareil de connecteur électrique (1 ; 100), comprenant :

35

un ensemble d'ouvertures de bornes pour recevoir en son sein un ensemble d'autres bornes ;
 un second dispositif de maintien de position de borne (4 ; 104) (TPA) ;
 une ouverture pour recevoir le second TPA (4 ; 104) ;

40

une première extrémité ayant l'ensemble d'ouvertures de bornes pour recevoir en son sein l'ensemble d'autres bornes ;
 dans lequel le logement mâle (2 ; 102) est conçu pour recevoir le logement femelle (3 ; 103) dans une seconde extrémité du logement mâle (2 ; 102), **caractérisé en ce que** le logement mâle comprend en outre : des nervures (6, 7, 8, 9, 10, 11 ; 106, 107, 108, 109, 110, 111) prévues sur le logement mâle (2 ; 102) le long d'une périphérie du second TPA (4 ; 104) pour protéger le second TPA (4 ; 104) d'un contact physique, dans lequel le logement mâle (2 ; 102) est conçu pour recevoir le logement femelle (3 ; 103) dans une seconde extrémité du logement mâle (2 ; 102), dans lequel le second TPA (4 ; 104) comporte, au niveau de chacun de ses côtés externes dans le sens de la largeur, deux éléments de mise en prise en forme de nervure s'étendant à partir de celui-ci pour permettre au second

45

50

55

TPA (4 ; 104) d'être à une position prédéfinie pendant le transport du logement mâle (2 ; 102) et à une position de verrouillage finale pour venir en prise avec l'ensemble d'autres bornes.

5

104) d'être à une position prédéfinie pendant le transport du logement mâle (2 ; 102) et à une position de verrouillage finale pour venir en prise avec l'ensemble de bornes.

3. Appareil de connecteur électrique (1 ; 100), comprenant :

un logement femelle (3 ; 103) selon la revendication 1, et

10

un logement mâle (2 ; 102) selon la revendication 2,

caractérisé en ce que les nervures (6, 7, 8, 9, 10, 11 ; 106, 107, 108, 109, 110, 111) sur le logement mâle (2 ; 102) sont conçues pour s'étendre au-delà du second TPA, lorsque le second TPA est à une position prédéfinie, pour protéger le second TPA (4 ; 104) d'un contact physique.

15

20

4. Procédé d'assemblage d'un appareil de connecteur électrique (1 ; 100), comprenant les étapes consistant à :

fournir un logement femelle (3 ; 103) selon la revendication 1 ;

25

recevoir un premier dispositif de maintien de position de borne (5 ; 105) (TPA) à l'intérieur d'une fente inférieure située en dessous du logement femelle (3 ; 103) ;

30

fournir un logement mâle (2 ; 102) selon la revendication 2 ;

recevoir un premier dispositif de maintien de position de borne (4 ; 104) (TPA) à l'intérieur d'une ouverture du logement mâle (2 ; 102) ;

35

recevoir le logement femelle (3 ; 103) dans le logement mâle (2 ; 102) ; dans lequel l'étape consistant à recevoir le premier TPA (5 ; 105) à l'intérieur de la fente inférieure située en dessous du logement femelle (3 ; 103) comprend en outre l'étape consistant à fournir au premier TPA (5 ; 105), au niveau de chacun de ses côtés externes dans le sens de la largeur,

40

deux éléments de mise en prise en forme de nervure s'étendant à partir de celui-ci pour permettre au premier TPA (5 ; 105) d'être à une position prédéfinie pendant le transport du logement femelle (3 ; 103) et d'être à une position de verrouillage finale pour venir en prise avec l'ensemble de bornes ; et dans lequel

50

l'étape consistant à recevoir le second TPA (4 ; 104) à l'intérieur de l'ouverture du logement mâle (2 ; 102) comprend en outre l'étape consistant à fournir au second TPA (4 ; 104), au niveau de chacun de ses côtés externes dans le sens de la largeur, deux éléments de mise en prise en forme de nervure s'étendant à partir de celui-ci pour permettre au second dispositif TPA (4 ;

55

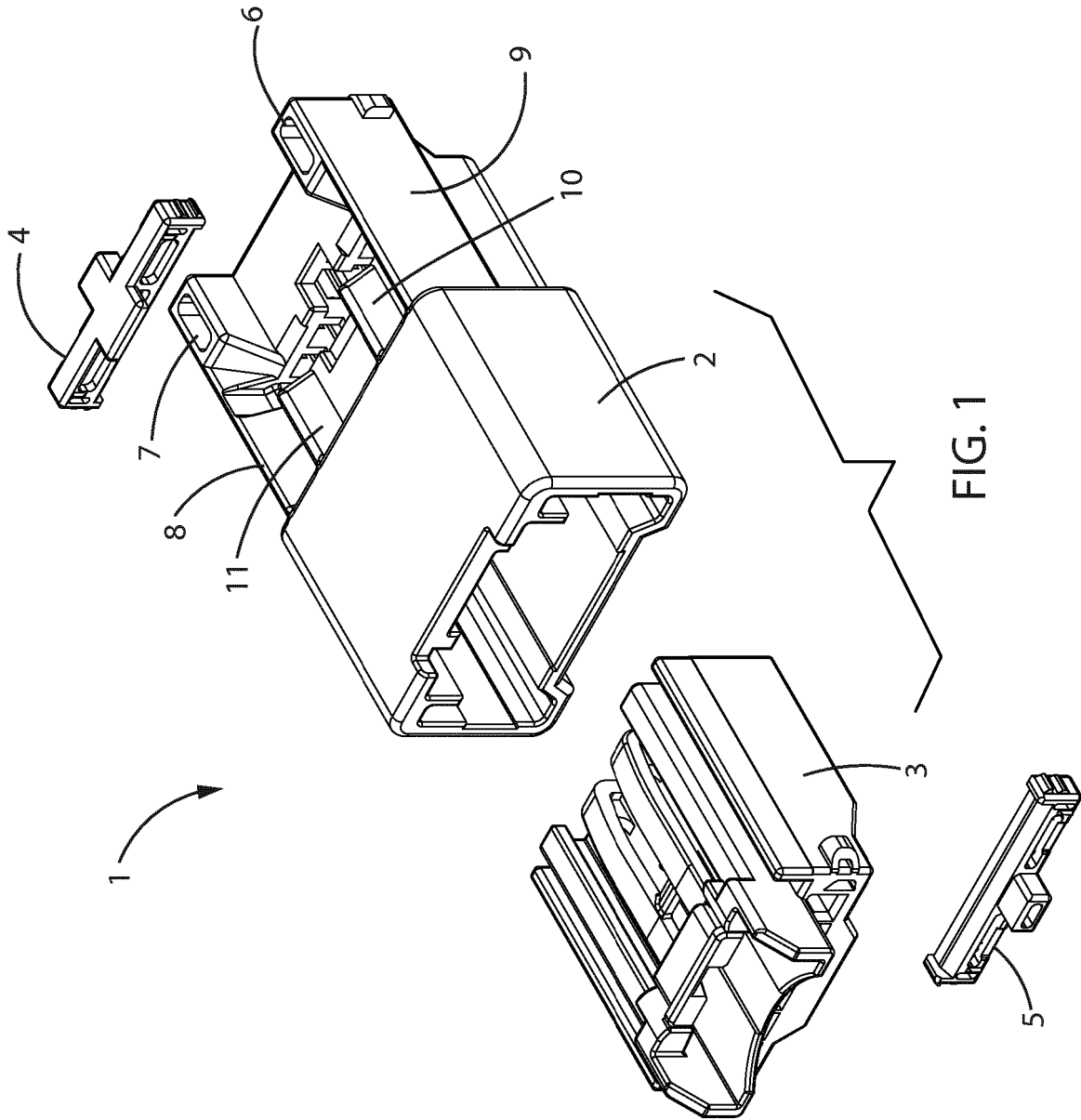

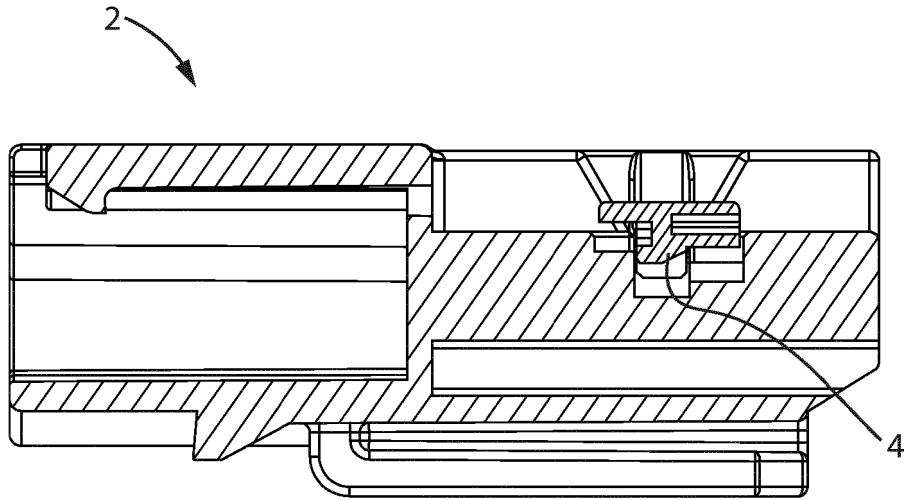

FIG. 2A

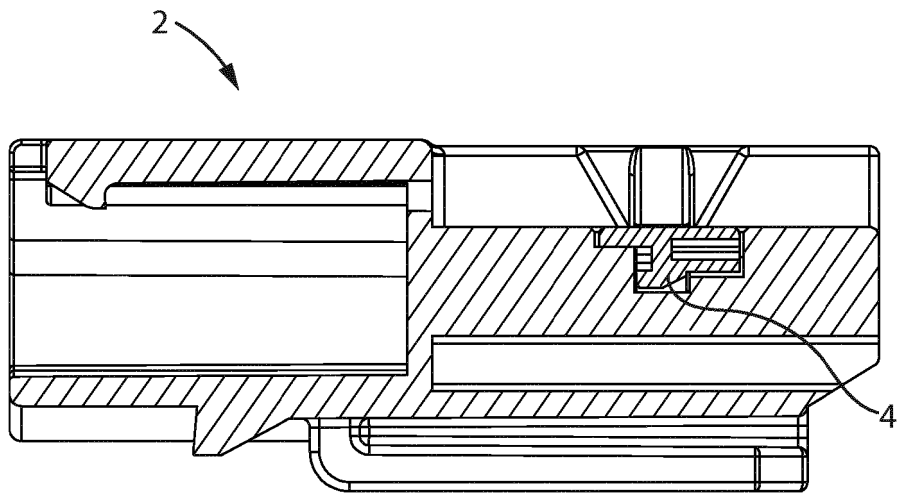

FIG. 2B

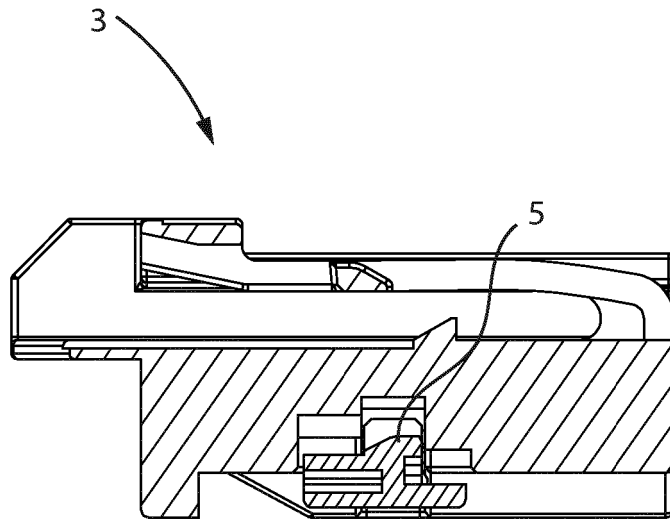

FIG. 3A

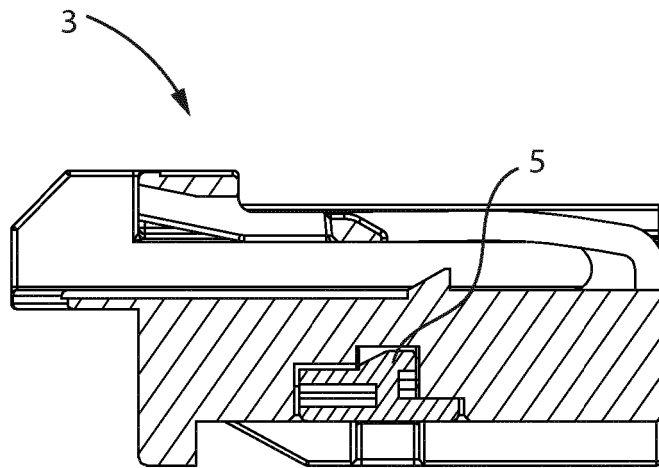
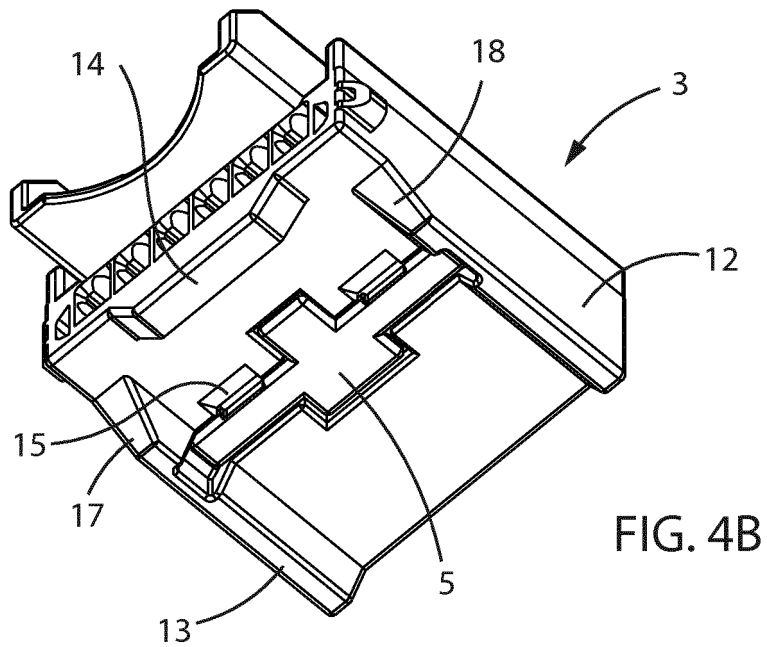
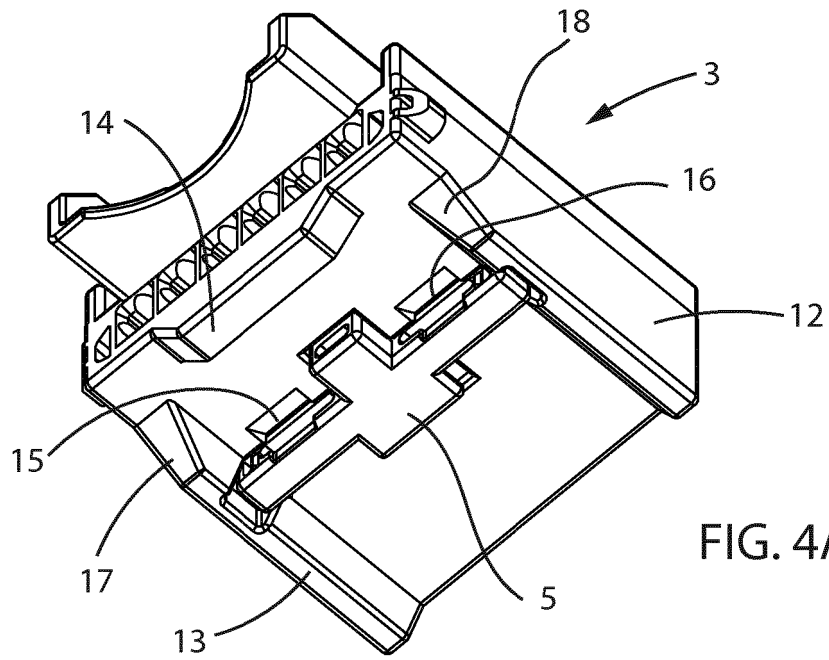

FIG. 3B



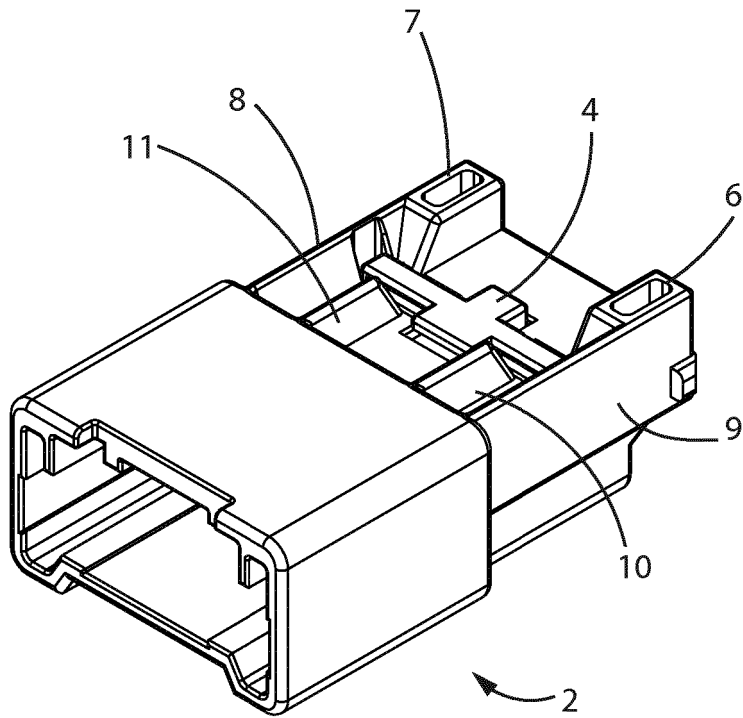

FIG. 5A

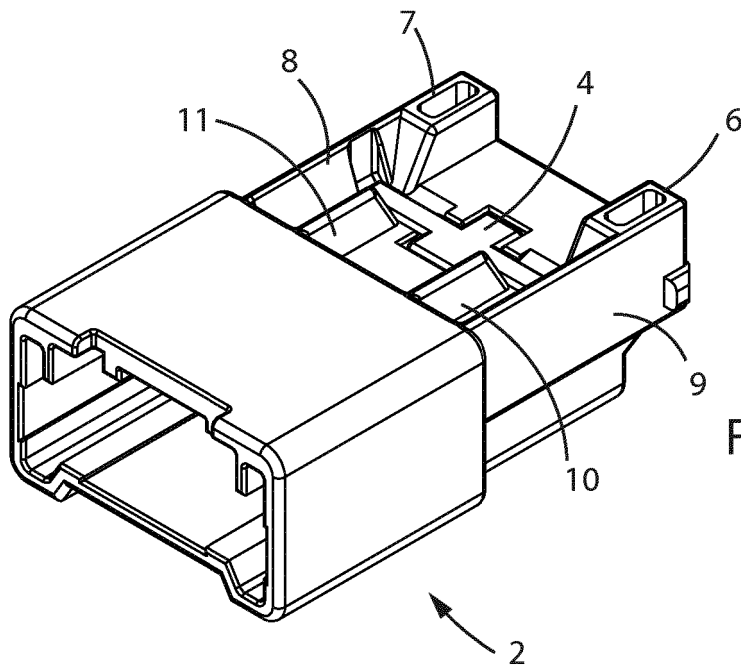

FIG. 5B

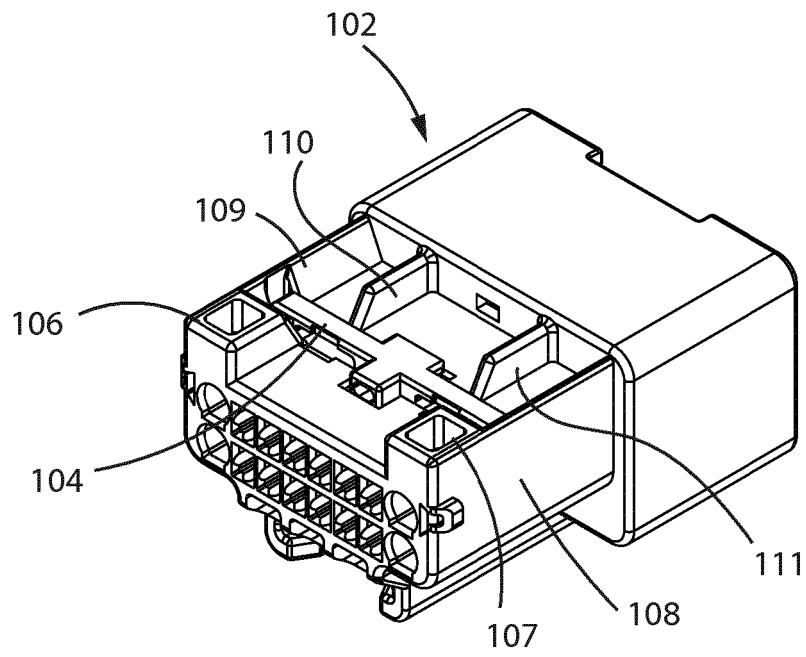
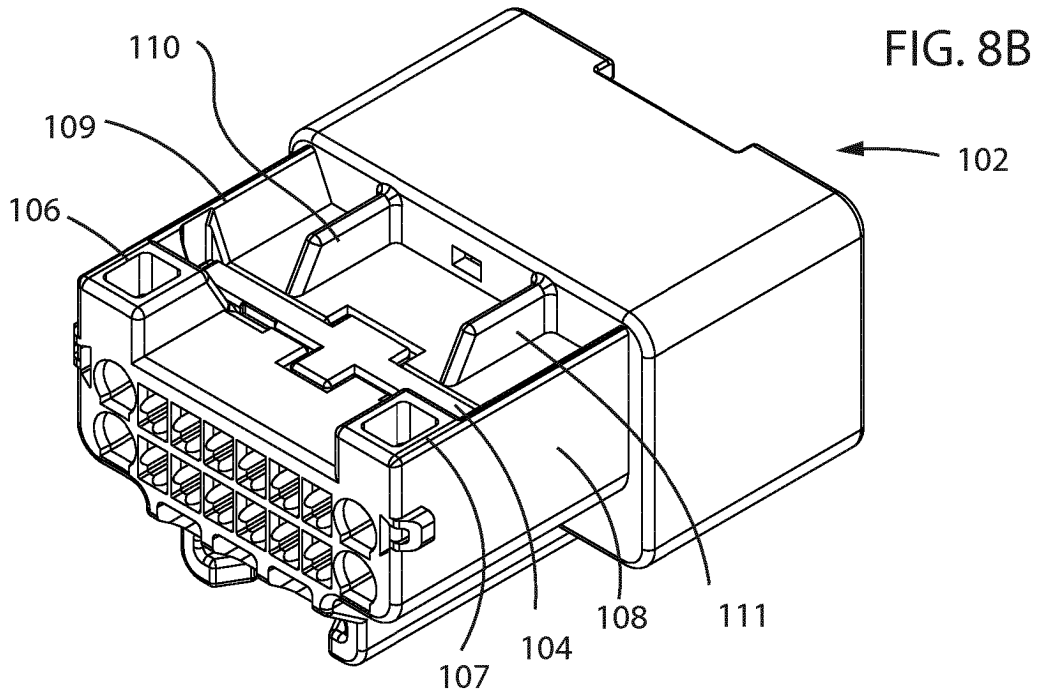
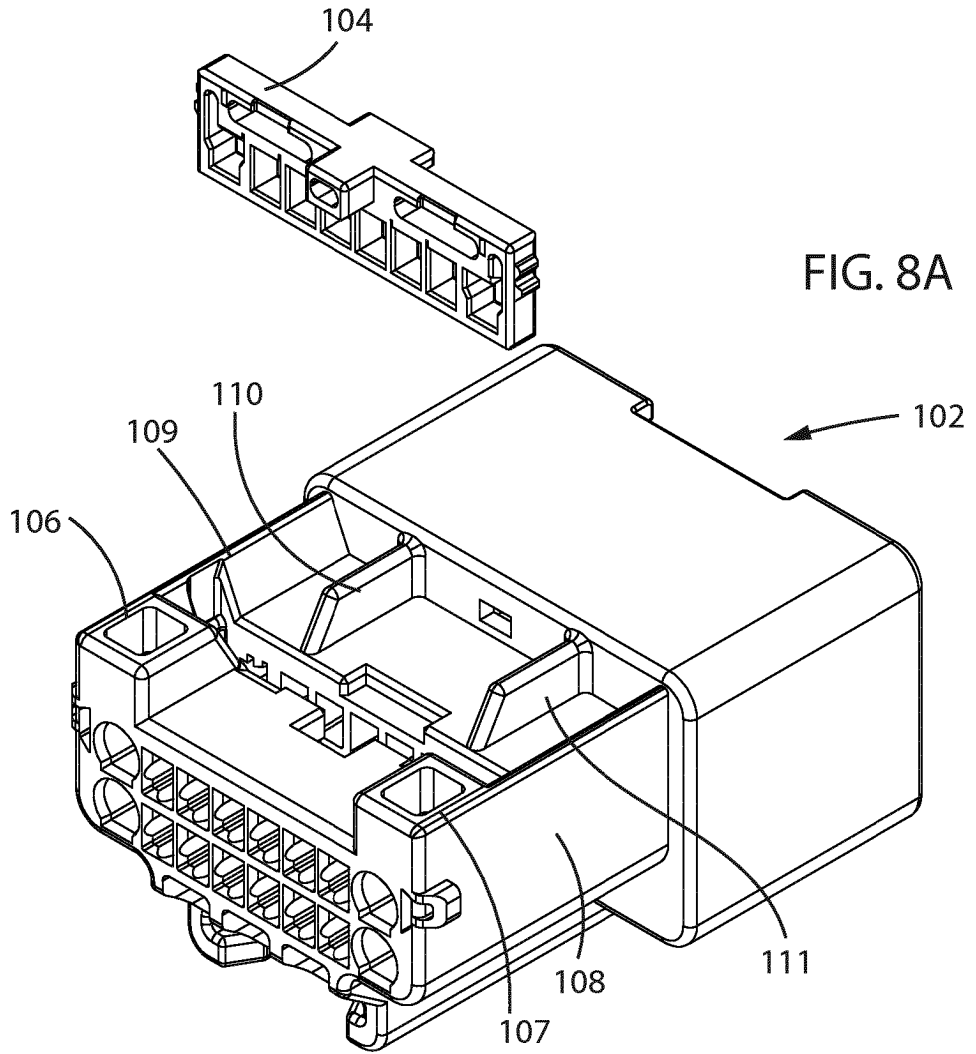

FIG. 7



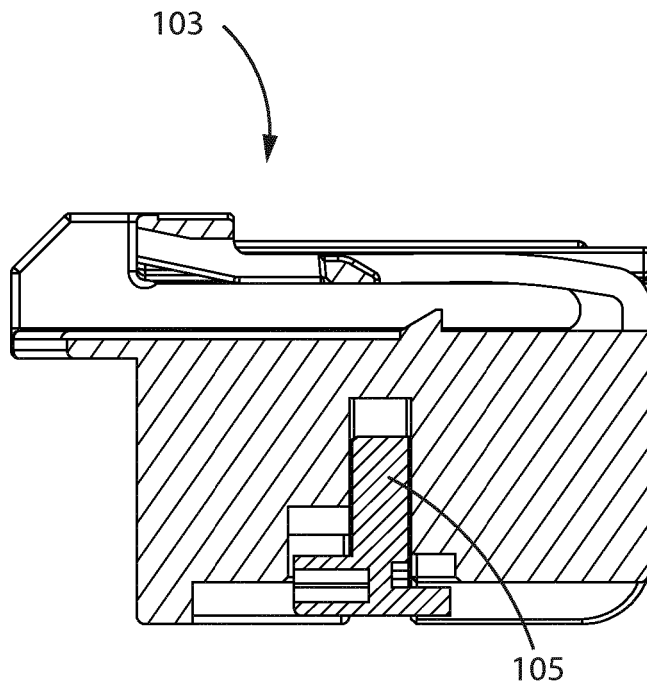

FIG. 9A

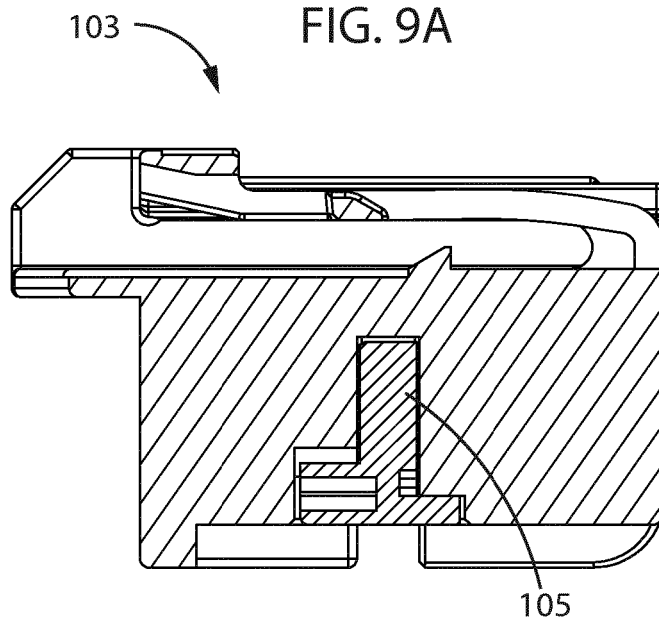

FIG. 9B

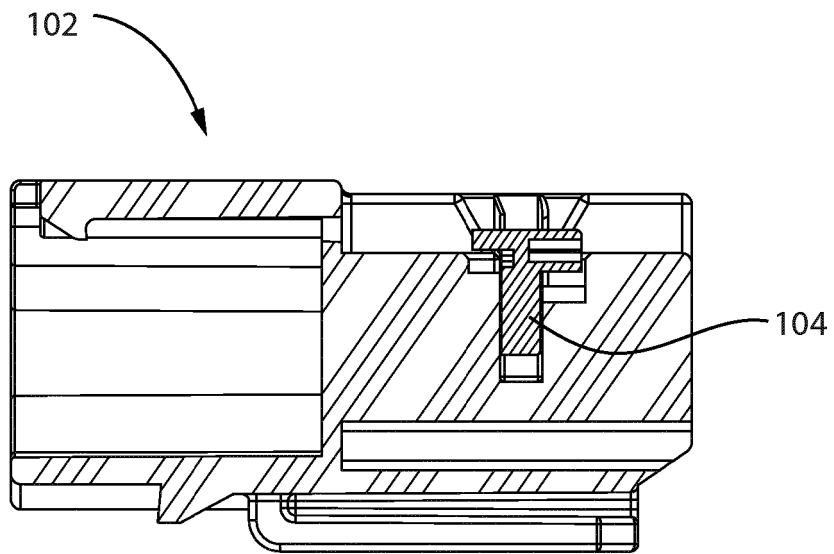

FIG. 10A

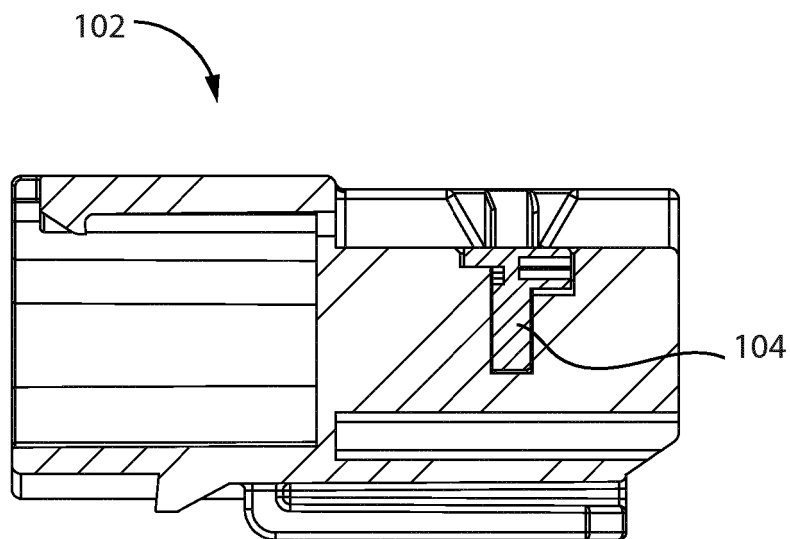

FIG. 10B

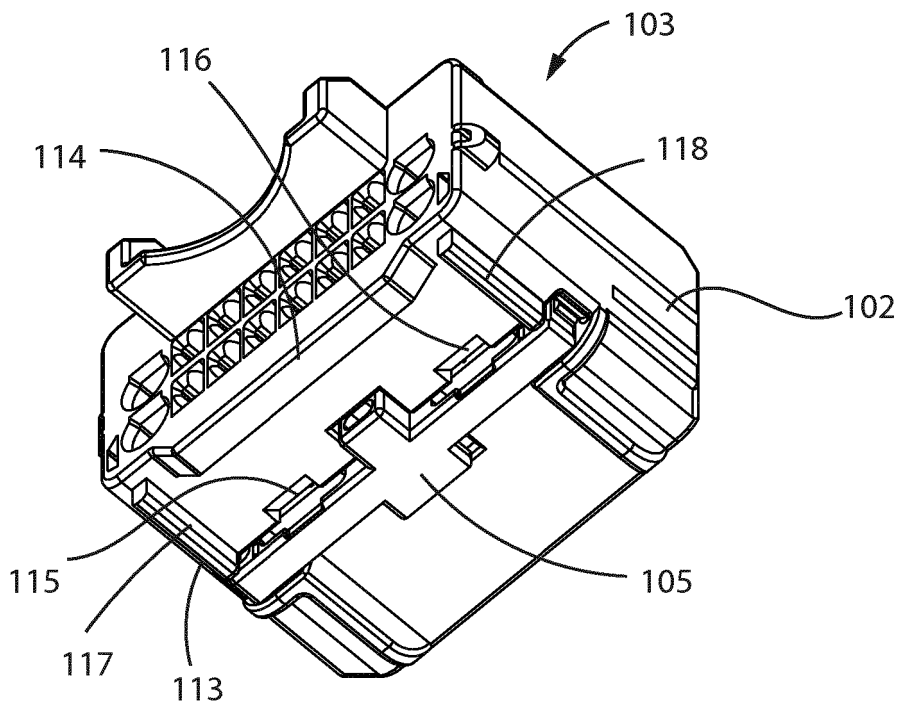

FIG. 11A

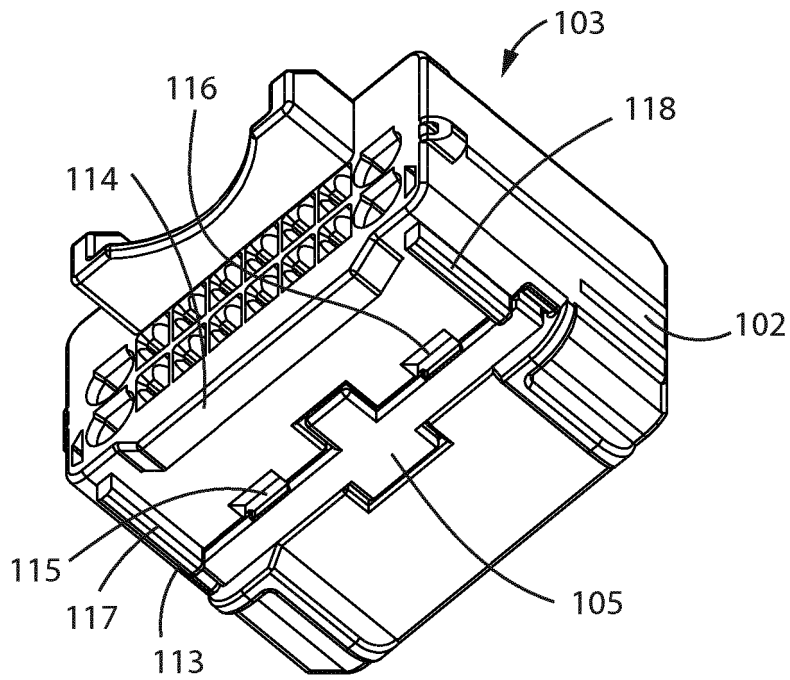

FIG. 11B

REFERENCES CITED IN THE DESCRIPTION

This list of references cited by the applicant is for the reader's convenience only. It does not form part of the European patent document. Even though great care has been taken in compiling the references, errors or omissions cannot be excluded and the EPO disclaims all liability in this regard.

Patent documents cited in the description

- US 6135802 A [0001]
- US 5830013 A [0001]