

(No Model.)

F. L. & F. A. JOY.
FOLDING STOOL.

No. 523,072.

Patented July 17, 1894.

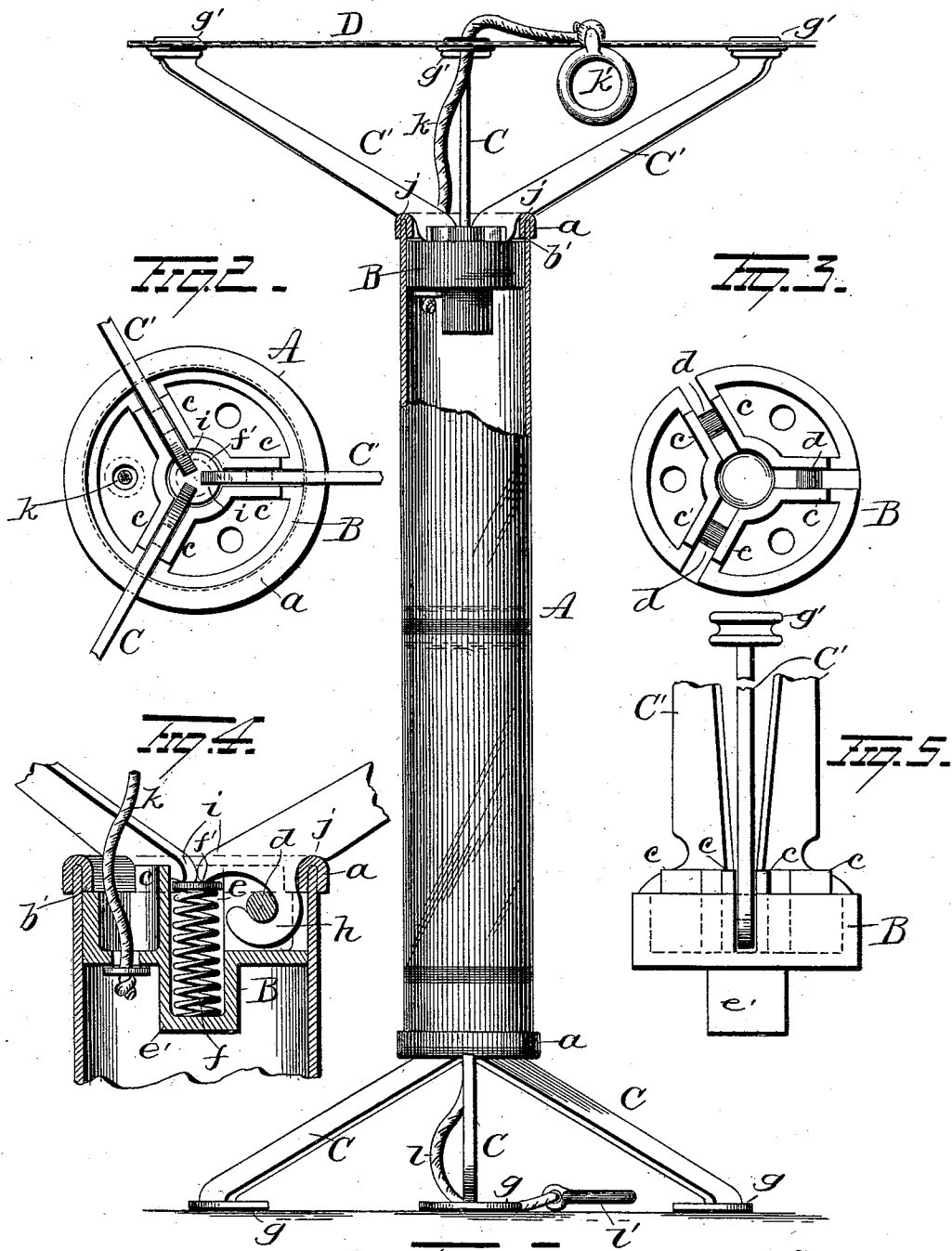

Witnesses
E. A. Nottingham
G. F. Downing

Inventors
F. L. & F. A. Joy
By H. A. Seymour
Attorney

UNITED STATES PATENT OFFICE.

FRANK L. JOY AND FRED A. JOY, OF FREMONT, NEBRASKA.

FOLDING STOOL.

SPECIFICATION forming part of Letters Patent No. 523,072, dated July 17, 1894.

Application filed September 6, 1893. Serial No. 484,894. (No model.)

To all whom it may concern:

Be it known that we, FRANK L. JOY and FRED A. JOY, of Fremont, in the county of Dodge and State of Nebraska, have invented certain new and useful Improvements in Folding Stools; and we do hereby declare the following to be a full, clear, and exact description of the invention, such as will enable others skilled in the art to which it appertains to make and use the same.

Our invention relates to an improvement in folding stools,—the object of the invention being to so construct a folding stool that the parts thereof can be readily assembled and not be liable to become loosened or displaced when the device is operated or in use.

A further object is to construct a folding stool in such manner that the legs and seat arms or supports shall be capable of being inclosed when not in use, and so that the use of detachable pivots shall be avoided.

A further object is to so construct a folding stool that the legs and seat arms or supports will be locked and effectually prevented from accidental collapse when the stool is in use.

A further object is to produce a folding stool which shall be simple in construction, easy to operate and effectual, in every respect, in the performance of its functions.

With these objects in view the invention consists in certain novel features of construction and combinations and arrangements of parts as hereinafter set forth and pointed out in the claims.

In the accompanying drawings: Figure 1 is a view of our improved stool, partly broken away. Figs. 2, 3, 4 and 5 are detail views.

A represents a cylindrical case or tube, made preferably of any suitable thin or sheet metal and decorated to suit the fancy of the designer. At each end of the case or tube A, collars *a* are secured in such manner as to produce annular shoulders *b*, within the ends of the tube. Before the collars *a* are secured in place, heads or castings B are inserted into the respective ends of the tube or casing and are adapted to have the legs and seat supports or arms attached to them respectively,—the escape of said heads or castings from the tube or case being prevented by their en-

agement (when the stool is in use) with the annular shoulders *b*.

The heads or castings B, are each made annular in form so that they can slide freely within the tube or casing A and have cast integral with them, a series of webs or flanges *c* which are so disposed that the ends of one web or flange will be parallel with and removed a short distance from the ends of the adjacent web or flange, such parallel ends of the webs or flanges constituting guides for the legs C and seat arms or supports C', the ends of which are connected to integral pins *d* between the parallel faces of the webs or flanges of the respective heads or castings A. The webs or flanges of each head or casting are so formed between their ends that they will, collectively, produce a socket or opening *e*, to which the proper depth is given by a hollow boss or enlargement *e'* made on the casting. In the socket *e* thus formed, a coiled spring *f* is located and adapted to project or expand the legs and arms or seat supports in a manner which will presently appear.

The construction of the legs C and the arms or seat supports C' are the same, except that the legs are provided at their outer ends with flat feet or disks *g* adapted to rest flatly on the ground or floor, while the outer ends of the arms or seat supports are provided with knobs or buttons *g'*, to which the canvas seat D is attached. The inner end of each arm or leg is made in the form of a hook *h* adapted to receive one of the integral pins *d*, the arm or leg being inserted between two of the webs or flanges in the casting A and its hook made to engage the pin *d*, before the spring *f* is inserted into its socket *e*. After all the legs or arms or seat supports (as the case may be) have been thus placed in position in the casting, the spring (which is preferably provided at its end with a head or disk *f'*) is placed in the socket *e* in the casting, and the disk *f'* at the end of the spring will be adapted to be engaged by a finger or projection *i* on each leg (or seat support). From this construction and arrangement of parts it will be seen that when either head or casting B is drawn from the end of the tube or casing A so that the legs (or seat supports) will project beyond the end thereof, the spring *f*, exerting its force on

the fingers *i* of the legs (or seat supports), will cause the free ends of said legs (or seat supports) to be projected or expanded outwardly into proper position for use.

5 Each leg *C* and arm or seat support *C'* is made with a notch or recess *j* just back of the hook *h*, and in these notches or recesses, the collars *a* (which are preferably made of stout material) are adapted to rest when the stool
10 is in use. From this construction it will be seen that when the stool is in use, the weight of the person thereon cannot cause the legs or seat to accidentally collapse, as a large portion of the weight will be on the notched portions of said arms and legs and as the ends
15 of the tube are inserted in said notches *j*, they will, in effect, be locked to the tube and any accidental movement will be effectually prevented. The greater the weight on the stool,
20 the less likely the parts are liable to accidentally collapse. When it is desired to inclose the legs and seat within the tube, it is simply necessary to compress them so as to bring them in alignment with the tube, when they
25 can be readily pushed into said tube or casing.

It will be observed that no removable pins are employed for pivotally connecting the legs and seat supports to the castings and therefore there is no liability of the legs or seat
30 supports becoming detached on account of the dropping out of one of its pivot pins; that the legs and seat supports can be easily and quickly placed in position and prevented from lateral or twisting movement by the flanges
35 or webs *c*; that the removal of the legs (or seat supports) is impossible without first removing the head from the tube.

In order to provide simple means for withdrawing the seat when it is desired to use the
40 stool, a cord *k* is attached at one end to the upper head *B* and passed through a perforation in the seat,—the free end of said cord being provided with a ring or knob *k'*. A similar cord *l* is attached to the lower head or

45 casting *B* for sliding the same in the tube or casting to withdraw the legs *C*, said cord *l* being also provided at its free end with a ring or knob *l'*.

Our improvements are very simple in construction, cheap to manufacture, easy to operate, not liable to get out of order or accidentally collapse and are effectual, in every respect, in the performance of their functions.

Having fully described our invention, what we claim as new, and desire to secure by Letters Patent, is—

1. In a folding stool, the combination with a tube, of a head located within the tube and adapted to slide freely therein, the said head having a centrally located recess or pocket, a
60 spring located in said pocket, and arms or legs each having a hook to engage a pin carried by the head and a finger against which the pressure of the spring is exerted, the said head and the arms or legs thereon, adapted
65 when folded to rest wholly within the tube substantially as set forth.

2. In a folding stool, the combination with a tube of two sliding heads therein, each head having pins and a central pocket, a spring
70 located in each pocket, arms pivoted to one head and legs to the other head, each arm and leg having a hook to engage its pivotal pin and a projecting finger against which the pressure of its spring is exerted, the said heads
75 and the arms and legs thereon adapted when folded to rest within the tube, substantially as set forth.

In testimony whereof we have signed this specification in the presence of subscribing
80 witnesses.

FRANK L. JOY.
FRED A. JOY.

Witnesses:

GEO. I. LOOMIS,
PETER PETERSEN,
GEO. E. INGLIS.