

May 19, 1964

J. R. DORMAN

3,133,771

STACKABLE SMALL PARTS CONTAINER

Filed April 11, 1962

3 Sheets-Sheet 1

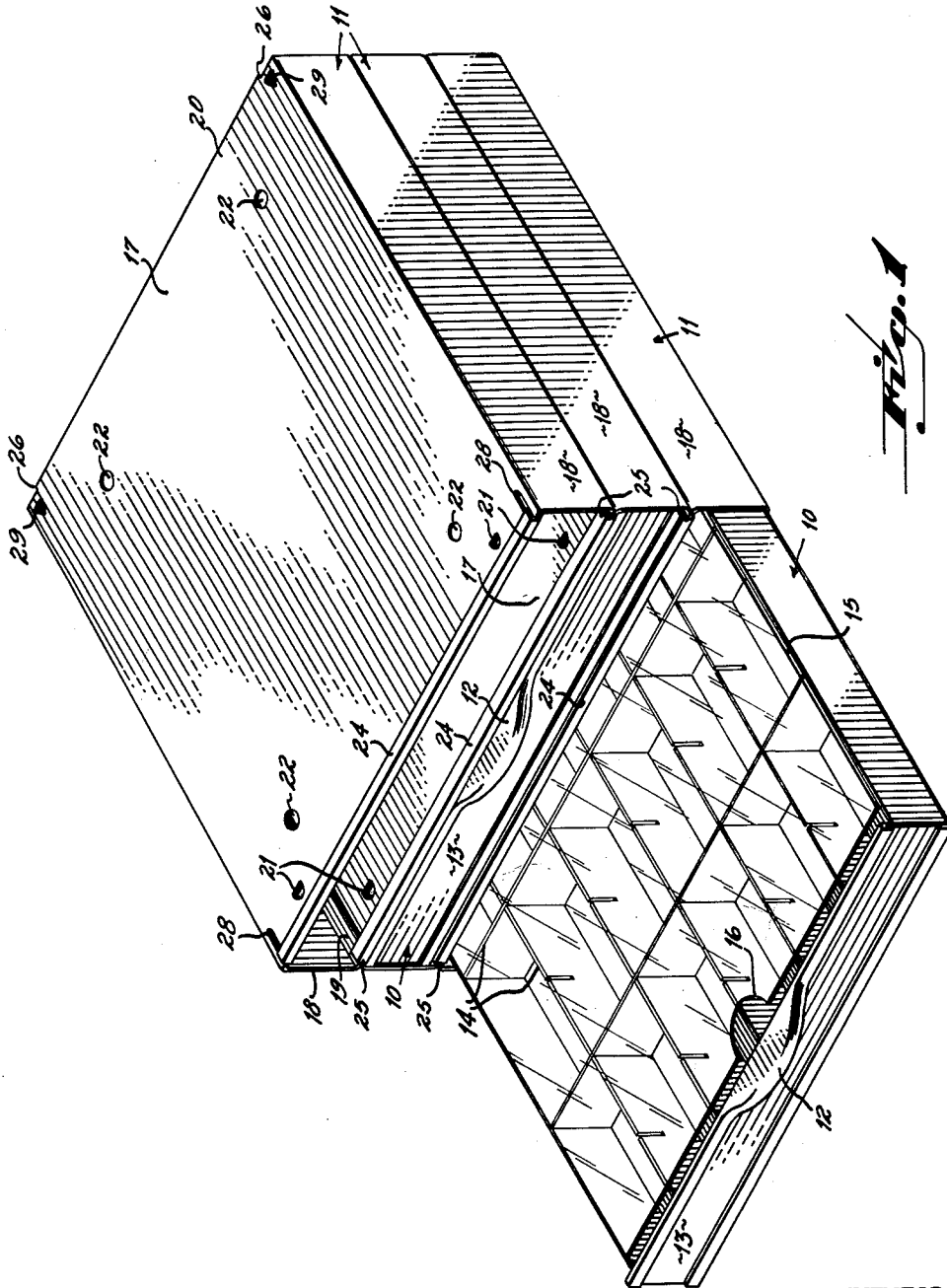

INVENTOR.

*Jack R. Dorman*

BY

*Wood, Herron & Evans*  
ATTORNEYS

May 19, 1964

J. R. DORMAN

3,133,771

STACKABLE SMALL PARTS CONTAINER

Filed April 11, 1962

3 Sheets-Sheet 2

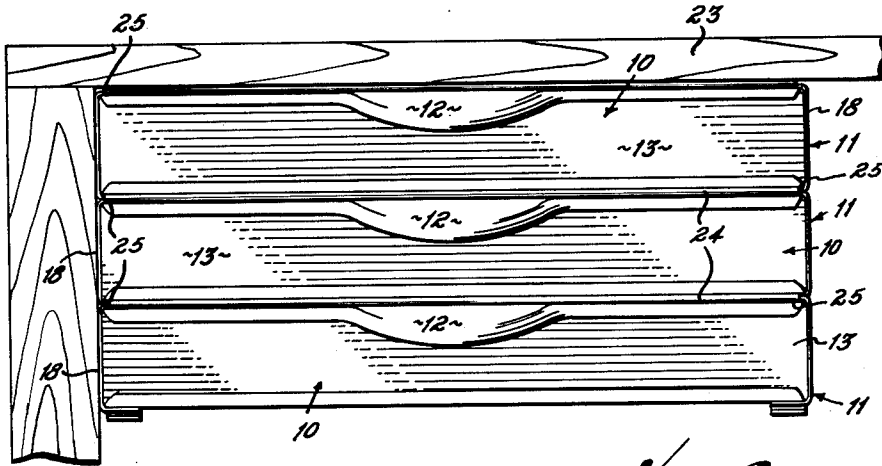

Fig. 2

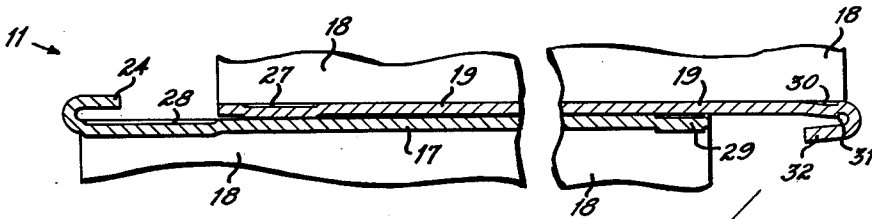

Fig. 6

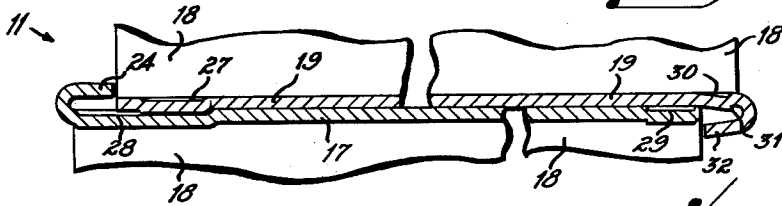

Fig. 7

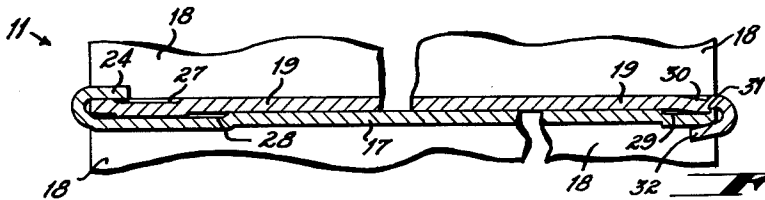

Fig. 8

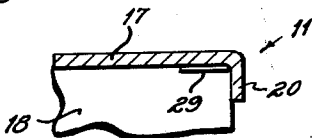

Fig. 9

INVENTOR.

Jack R. Dorman  
BY Wood, Herson and Evans  
ATTORNEYS

May 19, 1964

J. R. DORMAN

3,133,771

STACKABLE SMALL PARTS CONTAINER

Filed April 11, 1962

3 Sheets-Sheet 3

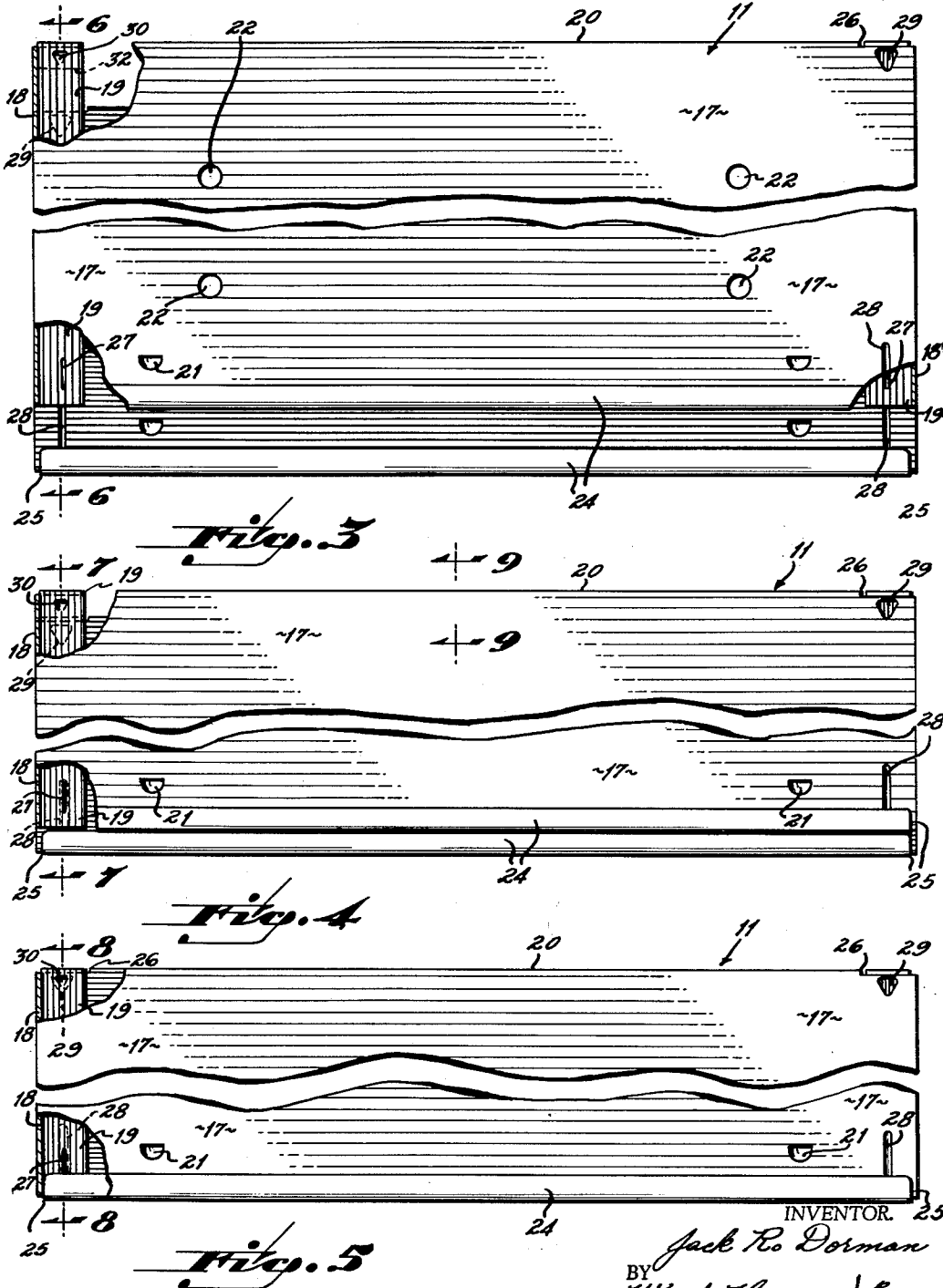

INVENTOR  
*Jack R. Dorman*  
BY  
*Wood, Hesson & Evans*  
ATTORNEYS

1

3,133,771

**STACKABLE SMALL PARTS CONTAINER**

Jack R. Dorman, 4084 Reading Road,  
Cincinnati 29, Ohio

Filed Apr. 11, 1962, Ser. No. 186,739

3 Claims. (Cl. 312-107)

This invention relates to containers and it is directed in particular to a container unit, comprising a drawer and a housing for the drawer, which is adapted to be locked in stacked relationship with a number of like units. A stack of these units may be mounted on a horizontal support such as a shelf on either the top or bottom. In one instance, the lowermost one of the stacked units rests upon the top of the shelf, and, in the other instance, the top one of the units is secured to the undersurface of the shelf such that the stack is suspended.

These units are designed primarily for use as containers in which small parts such as nuts, bolts, washers, cotter pins, screws, etc. may be sold. The drawers are adapted to be divided into compartments of various sizes by means of partitions so that one drawer may be utilized for parts of different sizes and kinds or the partitions can be left out so that a drawer may be used for only one size or kind of part.

The invention is concerned specifically with the construction of the housing in which the drawer is received, which construction permits one unit to be securely locked to another unit. The locking operation may be performed by placing one unit on top of another, in the event that the stack is resting upon the top of a shelf, or it may be carried out by securing one unit to the bottom of another, in the event that the stack is suspended from the bottom of a shelf, the objective being to permit the addition of units to the stack at any time. Thus, the purchaser of small parts in these containers, can make up an inventory of parts and have these parts arranged neatly and orderly in drawers which, in the preferred embodiment of the invention, are premarked with the necessary information to identify their contents.

One of the objectives of the invention has been to provide a locking construction for small parts containers which is easy to manipulate and which provides a secure lock between two units.

Another objective of the invention has been to provide a locking construction for units of this type which insures that one unit will be aligned precisely with the unit to which it is being attached.

Another objective has been to provide a latch for units of the type set forth which snaps into locking condition so that it is virtually impossible, without using tools, to separate them, this being done to insure that the units do not come apart inadvertently. This latter feature is important when a stack of units is suspended from the underside of a support such as a shelf or a work bench.

Other objectives and features of the invention will be readily apparent to those skilled in the art from the following detailed description of the drawings, in which:

FIGURE 1 is a perspective view showing three of the containers of this invention in stacked, locked relationship.

FIGURE 2 is a front elevational view showing three of the stacked, locked units secured to the underside of a horizontal surface such as might be provided by the underside of a shelf or the underside of a work bench or table.

FIGURE 3 is a fragmentary top plan view, in which sections are broken away for illustrative purposes, showing the first step in locking two of the units together.

FIGURE 4 is a view similar to FIGURE 3 showing an intermediate step in locking two of the units together.

FIGURE 5 is a view similar to FIGURES 3 and 4

2

showing the relationships of the various parts of two containers in locked condition.

FIGURE 6 is a fragmentary cross-sectional view taken on the line 6-6 of FIGURE 3.

5 FIGURE 7 is a view similar to FIGURE 6 taken on the line 7-7 of FIGURE 4.

FIGURE 8 is a view similar to FIGURES 6 and 7 taken on the line 8-8 of FIGURE 5.

10 FIGURE 9 is a fragmentary cross sectional view taken on the line 9-9 of FIGURE 4.

Each container unit of this invention comprises a drawer, designated generally by the numeral 10, and a housing for the drawer, designated generally by the numeral 11. In the preferred embodiment both the drawer and the housing are made of sheet metal. The construction of the drawer itself is relatively unimportant insofar as the invention is concerned. It is preferred however, that the front of the drawer be provided with a handle 12 and that it comprise a channel 13 to receive a strip of paper upon which the contents of the drawer may be indicated. It is also preferred as shown in FIGURE 1 that each drawer be divided into a series of compartments by means of interlocking partition walls 14. A clear sheet 15 of plastic may be utilized to cover the compartments within a drawer, this sheet of plastic being secured to the upper edge of the back of the drawer. The clear plastic sheet may also, if desired, have indicia printed thereon to indicate the sizes and types of parts within the various compartments. The front center of the plastic sheet may have a finger notch 16 in it to assist in raising it.

The housing of each unit comprises a rectangular top panel 17 having side walls 18-18 which are vertical and which are turned down at right angles from opposite side edges of panel 17. The lower edges of the side walls 18-18 are turned inwardly at a right angle toward one another to provide flanges 19-19. The two flanges are coextensive with the lower edges of side walls 18-18. The housing or shell thus fabricated is opened at the front and at the back and over substantially all of its underside with the exception of the two flanges 19-19. The housing is of a size to receive the drawer in sliding relation with the two flanges 19-19 providing runners for the drawer. As shown in FIGURE 9, the rear edge of top panel 17 is turned down to provide a depending flange 20 which serves as a stop for the drawer in its closed position. Adjacent to the front corners, the top panel 17-17 is lanced and then pressed in to provide a pair of semicircular abutments 21-21 which serve as stops for the drawer in its forwardmost position. These stops cooperate with the back wall of the drawer and in the initial insertion of the drawer it may be tipped up in order to clear these abutments. Also as shown in FIGURE 1 the top panel has four holes 22 stamped through it adjacent to the four corners, these holes providing a means of securing the uppermost one of a stack of these units to a member such as a shelf indicated at 23 in FIGURE 2. In an installation of this type four wood screws, one for each hole 22, may be used. Obviously, 60 bolts or other types of fasteners may be utilized if desired.

In the stacking of two units in the locked condition illustrated in FIGURE 1 there are two considerations. The first is properly aligning the unit which is to be added with respect to the unit to which it is to be locked. The other is the actual locking of the units. In this invention the same elements which serve as locking devices serve aligning functions. Generally, in the locking of two units together the upper one is placed so that its side walls are contiguous to the side walls of the lowermost one. However, the uppermost one is shifted relative to the lower one so that it is offset to the rear. In this posi-

tion, the aligning elements of the invention come into play. In order to affect a lock it is necessary only to force the top one of these two containers relatively forwardly to bring the front of the upper one into a position in which it is directly above the lower one so that the front and back walls of the drawers within the housings are relatively contiguous.

In the preferred embodiment of the invention top panel 17 is configured at its forward edge to provide a rearwardly opening locking channel 24. This channel is formed by turning the metal of the top panel up at a right angle and then turning it again at a right angle so that the locking channel opens toward the rear. As will be seen, it is not absolutely necessary that the locking channel be continuous to extend substantially completely across the forward edge of the channel, as shown in FIGURE 1, since it is only the two ends of the channel which are functional in the locking sense. The continuous channel is preferred, however, in order to rigidify the front edge of the panel. At the rear the flange 20, which is turned down to provide a stop for the drawer serves to rigidify the panel. At the sides, the walls 18—18 serve this function so that the top panel is rigid along all four edges. As best shown in FIGURES 3, 4 and 5 the ends of channel member 24 stop short as at 25 of the side walls 18—18 by an amount equal to the thickness of a side wall plus a clearance factor. This will be explained later. The depending flange 20 at the rear also stops short of the side walls as at 26—26 by an amount equal to the width of a flange 19 plus a clearance factor. This will also be explained later.

Each of the flanges 19—19, adjacent to its forward end has a guide ridge 27 which is aligned from front to back, paralleling the adjacent side wall 18. This ridge may be formed by displacing the sheet metal of which the flange is made in a simple stamping operation. The ridge itself projects from the underside of the flange as is best shown in FIGURES 6, 7, and 8. Upper panel 17 has a guide groove 28 stamped into it in each corner. These grooves are considerably longer than the guide ridges 27 and they extend underneath the locking channel 24.

Each of the two rear corners of top panel 17 is configured to provide a triangularly shaped depression or seat 29. It is important that each triangularly shaped depression be oriented as shown so that the base parallels the rear edge of panel 17 and so that the apex is disposed toward the front.

Each of the flanges 19—19, adjacent to the rear end thereof has a triangularly shaped boss 30 formed in it which boss is also oriented in the same way that each of the depressed seats 29 is oriented. In this instance, however, the boss is slanted so that the base of the triangle extends downwardly from the flange to the greatest extent, with the apex of the triangle substantially in the plane of the undersurface of the flange. This provides an edge 31 which, in a stack, becomes the ultimate locking member. The rear edge of each flange 19—19 is turned downwardly and forwardly to provide a locking clip 32. As may be seen in FIGURES 6, 7 and 8 this locking clip projects underneath the triangularly shaped boss 30 and it cooperates with the boss to form a secure lock.

In the assembling of two units into stacked, locked condition the uppermost one is placed upon the one to which it is to be fastened in such a position that the side walls are aligned vertically, but as is best illustrated in FIGURE 3, the upper unit of the two is offset to the rear of the lower unit. The upper unit is then moved forwardly until the guide ridges on the flanges 19—19 of the upper unit engage into the guide grooves 28—28 in top panel 17 of the lower unit. This position of the two units is shown in FIGURES 4 and 7. From this aligned position the upper one of the two units is moved straight ahead into the positions of the units illustrated in FIG-

URES 5 and 8. This movement requires some force, and in this movement the two ends 25—25 of locking channel 24 and the two outer sides of the locking clips 32—32 move into slip-fit relation with adjacent side walls of the respective units. In the case of the locking channel 24 the outer ends 25—25 contact the inner surfaces of side walls 18—18 of the upper one of the two units in slip-fit relation. In the case of the outer edges of clips 32—32 the contact is with the inner surface of the side walls of the lower unit. Here again, this is a slip-fit relationship so that no binding occurs. In addition to these guides which are rather loosely fitting ones, the guide ridges 27—27 on the forward ends of the two flanges 19—19 are held down into the guide grooves 28—28 of the upper panel of the lower unit by means of the locking channel 24, so as to prevent any sideward movement of the forward end of the uppermost unit relative to the lower unit. At the rear the triangularly shaped bosses 30—30 ride into positions in which they are initially over the depressed seats 29—29. Once the uppermost box is fully forward so that the front edges of the flanges 19—19 abut the bottom of the locking channel, the bosses 30—30 fit exactly with the depressed seats 29—29. In this position rear edge 31 of each of the bosses on flanges 19—19 abut against the base of the triangularly shaped seat 29 so that it is impossible to withdraw the upper one of the two units without opening the locking clip 32. This is best shown in FIGURE 8.

It is found that by making the bosses in the triangular shapes shown and making the depressed seats in the triangular shapes shown, a guiding action is obtained which insures that the bosses seat exactly within the depressed seats 29—29. This is a snap lock action due to the resiliency of the locking clips 32—32. Thus, the rear parts of the two units are aligned with one another and held in this relationship by the locking clips 32—32. At the forward ends the two units are held together by the locking channel 24.

It may be seen therefore that a stack of these units becomes, in effect, a rigid cabinet and that any number of the units, within practical limits may be locked together to provide a neat and orderly inventory of small parts.

Having described my invention, I claim:

1. A small parts container adapted to be locked in stacked relationship with a number of like containers comprising a drawer, a housing for said drawer, said housing comprising a rectangular top panel, side walls depending from the side edges of said panel, the lower edges of said side walls being turned inwardly toward one another to provide a pair of flanges disposed in spaced parallel relation, said drawer being of a size to fit within said container with its opposite side edges resting upon said flanges, a channel opening rearwardly immediately above the front edge of said top panel, locking clips opening forwardly immediately beneath the rear ends of said flanges, a depression in the rear portion of each of said flanges above said locking clips, matching depressions in the corners of the top panel vertically aligned with the depressions in the flanges, a ridge paralleling the adjacent side wall on the underside of each flange adjacent to the forward end thereof, a groove in the top panel immediately above each of said ridges, the grooves in the top panel being longer than the ridges on the flanges and extending into said rearwardly opening channel, whereby one container may be placed on the top of another, identical container with the ridges on the undersides of the flanges of the upper one of the two containers with the grooves in the top panel of the lowermost one of the two containers and the upper container then moved forwardly relative to the lower container to engage the front edges of the flanges on the upper container into the rearwardly opening channel at the forward edge of the

5

top panel of the lower container, and to engage the clips at the rear ends of the flanges of the upper container with portions of the rear edge of the top panel of the lower container while bringing the depressions on the rear portions of the flanges of the upper container into engagement with the depressions at the rear corners of the top panel of the lower one of the two containers.

2. A small parts container as set forth in claim 1 in which said depressions are triangularly shaped with their bases paralleling the rear edge of said top panel.

3. A small parts container adapted to be locked in stacked relationship with a number of like containers comprising a drawer, a housing for said drawer, said housing comprising a rectangular top panel, side walls depending from the side edges of said panel, the lower edges of said side walls being turned inwardly toward one another to provide a pair of flanges disposed in spaced parallel relation, said drawer being of a size to fit within said container with its opposite side edges resting upon said flanges, a channel opening rearwardly immediately above the front edge of said top panel, locking clips opening forwardly immediately underneath the

6

rear end portions of said flanges, a triangularly shaped depression in the rear portion of each of said flanges above said locking clips, matching triangularly shaped depressions in the corners of the top panel vertically aligned with the triangularly shaped depressions in the flanges, a ridge on the underside of each flange adjacent to the forward end thereof, and a groove in the top panel immediately above each of said ridges, the grooves in the top panel being longer than the ridges on the flanges and extending into said rearwardly opening channel.

References Cited in the file of this patent

UNITED STATES PATENTS

15	450,196	See .....	Apr. 14, 1891
	1,656,868	Davis .....	Jan. 17, 1928
	1,676,930	Schmitz .....	July 10, 1928
	2,181,918	Scheinman .....	Dec. 5, 1939
	2,227,884	Gymer .....	Jan. 7, 1941
20	2,237,176	Dorman .....	Apr. 1, 1941
	2,242,263	Regenhardt .....	May 20, 1941
	2,295,893	Detrich .....	Sept. 15, 1942

UNITED STATES PATENT OFFICE  
CERTIFICATE OF CORRECTION

Patent No. 3,133,771

May 19, 1964

Jack R. Dorman

It is hereby certified that error appears in the above numbered patent requiring correction and that the said Letters Patent should read as corrected below.

Column 4, line 70, for "with" read -- within --.

Signed and sealed this 29th day of September 1964.

SEAL)

Attest:

NEST W. SWIDER  
Attesting Officer

EDWARD J. BRENNER  
Commissioner of Patents