

D. M. SOMERS.
Dies for Drawing Tubes.

No. 152,185.

Patented June 16, 1874.

Fig. 1

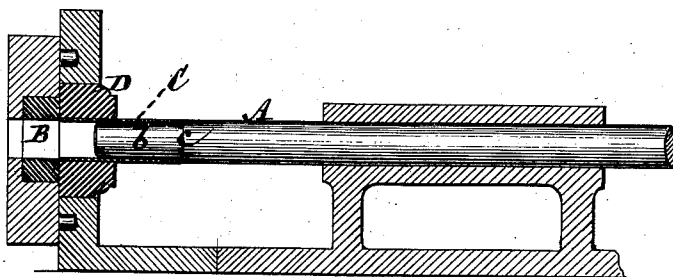
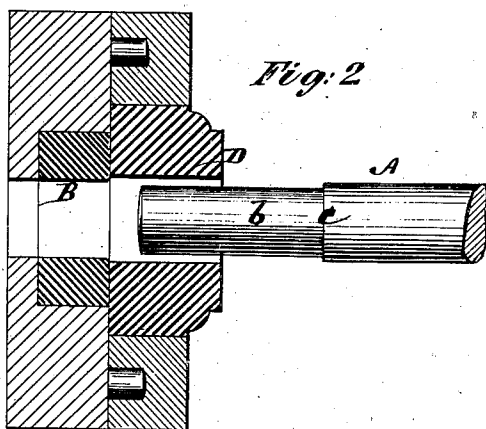

Fig. 2



Witnesses:
Michael Ryan
Fred. Warner

Daniel M. Somers
by his Attorney
Brown & Allen

UNITED STATES PATENT OFFICE.

DANIEL M. SOMERS, OF BROOKLYN, NEW YORK.

IMPROVEMENT IN DIES FOR DRAWING TUBES.

Specification forming part of Letters Patent No. 152,185, dated June 16, 1874; application filed April 20, 1874.

To all whom it may concern:

Be it known that I, DANIEL M. SOMERS, of Brooklyn, in the county of Kings and State of New York, have invented an Improvement in Machines for Making Split Metal and other Tubes, of which the following is a specification:

This invention relates to that method or process of making split tubes suitable for pen-holders and other purposes, of which the machine described in Letters Patent No. 130,758, issued to me August 20, 1872, is the practical embodiment, so far, at least, as regards the forcing of the tube-blank, after being bent around a mandrel to meet at its edges, through a steel or hard draw-die, by a shoulder on the mandrel acting against the back end of the tube-shaped blank, such draw-die serving to insure the perfect closing of the tube, and to give it a neat or draw finish, as well as a true or cylindrical shape. It is to this part of said machine that the present improvement refers; and it consists in a combination, with the draw-die and shouldered mandrel, of a supplementary die or clamp, arranged in front of the draw-die and in line with it, to keep the tube closed around the reduced portion of the mandrel, and prevent it from riding over the shoulder of the latter while being entered or forced through the draw-die.

The machine, generally, may be set either to work horizontally, vertically, or otherwise; and it will be unnecessary here to specify means for preparing the metal or other blank, and for lapping it around or depositing it on the reduced portion of the mandrel corresponding to the interior size of the tube to be produced, as such means may be the same as employed in my machine hereinbefore referred to.

In the accompanying drawing, Figure 1 represents a longitudinal sectional view of the devices to which my improvement relates, together with a tube in the course of being

made; and Fig. 2, a sectional view upon a larger scale of the dies and mandrel without the tube.

A is the mandrel, arranged to slide through one or more suitable bearings, and occupying a concentric position in relation with the dies. This mandrel, or its reduced forward portion *b*, which corresponds with the interior size of the tube to be produced, is formed with a rear collar or shoulder, *c*, of a diameter that will admit of its passage through the draw-die B.

The tube or bent blank C, being formed or arranged around the reduced portion *b* of the mandrel, with its longitudinal edges approximating or meeting, and its back end resting against the shoulder or collar *c* of the mandrel, is forced by said shoulder with the requisite power or pressure through the steel or hard draw-die B, to insure the perfect closing of and necessary finish of the tube. As, however, in making tubes of thin metal, the tube, in entering and being forced through the draw-die, is apt to ride over the shoulder *c* of the mandrel, I arrange, immediately in front of the draw-die B, a slightly larger die or clamp, D, of a size that will keep the tube closed around the portion *b* of the mandrel, so that it cannot slip back over the shoulder *c*.

This die or clamp D, which may either be a close one, or a split one kept closed by a spring, is not designed to exert any drawing tendency on the tube, but simply to serve, in connection with the shoulder *c*, to insure the projection of the tube through the draw-die.

I claim—

The combination of the advance closing die or clamp D with the shouldered mandrel A and draw-bar B, substantially as and for the purposes herein set forth.

D. M. SOMERS.

Witnesses:

MICHAEL RYAN,
VERNON H. HARRIS.