

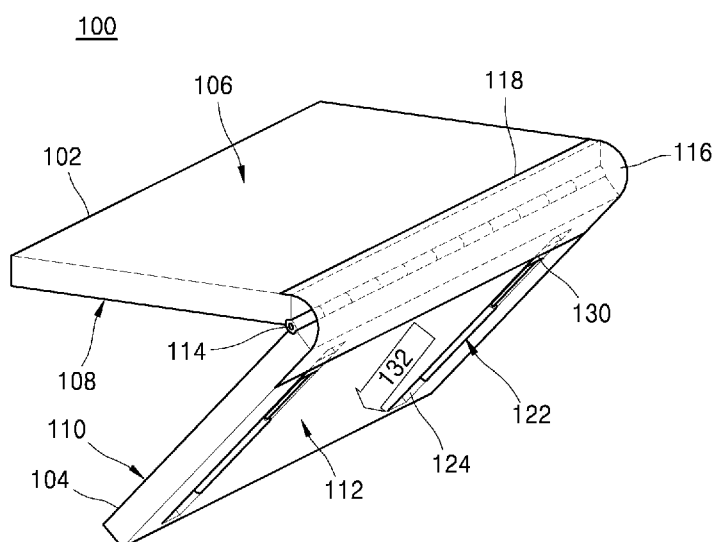

- (51) International Patent Classification:  
*H04M 1/02* (2006.01)
- (21) International Application Number:  
PCT/KR2017/008659
- (22) International Filing Date:  
10 August 2017 (10.08.2017)
- (25) Filing Language: English
- (26) Publication Language: English
- (30) Priority Data:  
62/373,271 10 August 2016 (10.08.2016) US  
15/672,940 09 August 2017 (09.08.2017) US
- (71) Applicant: SAMSUNG ELECTRONICS CO., LTD.  
[KR/KR]; 129 Samsung-ro, Yeongtong-gu, Suwon-si,  
Gyeonggi-do 16677 (KR).
- (72) Inventors: MANUEL, Steven; 665 Clyde Avenue, Mountain View, California 94043 (US). SADI, Sajid; 665 Clyde Avenue, Mountain View, California 94043 (US). AUMILLER, Curtis; 665 Clyde Avenue, Mountain View, California 94043 (US). BRENNER, Thomas; 665 Clyde Avenue, Mountain View, California 94043 (US).
- (74) Agent: Y.P.LEE, MOCK & PARTNERS; 12F Daelim Acrotel, 13 Eonju-ro 30-gil, Gangnam-gu, Seoul 06292 (KR).
- (81) Designated States (unless otherwise indicated, for every kind of national protection available): AE, AG, AL, AM, AO, AT, AU, AZ, BA, BB, BG, BH, BN, BR, BW, BY, BZ, CA, CH, CL, CN, CO, CR, CU, CZ, DE, DJ, DK, DM, DO, DZ, EC, EE, EG, ES, FI, GB, GD, GE, GH, GM, GT, HN, HR, HU, ID, IL, IN, IR, IS, JO, JP, KE, KG, KH, KN, KP, KR, KW, KZ, LA, LC, LK, LR, LS, LU, LY, MA, MD, ME, MG, MK, MN, MW, MX, MY, MZ, NA, NG, NI, NO, NZ, OM, PA, PE, PG, PH, PL, PT, QA, RO, RS, RU, RW, SA, SC, SD, SE, SG, SK, SL, SM, ST, SV, SY, TH, TJ, TM, TN, TR, TT, TZ, UA, UG, US, UZ, VC, VN, ZA, ZM, ZW.
- (84) Designated States (unless otherwise indicated, for every kind of regional protection available): ARIPO (BW, GH, GM, KE, LR, LS, MW, MZ, NA, RW, SD, SL, ST, SZ, TZ, UG, ZM, ZW), Eurasian (AM, AZ, BY, KG, KZ, RU, TJ, TM), European (AL, AT, BE, BG, CH, CY, CZ, DE, DK, EE, ES, FI, FR, GB, GR, HR, HU, IE, IS, IT, LT, LU, LV, MC, MK, MT, NL, NO, PL, PT, RO, RS, SE, SI, SK, SM, TR), OAPI (BF, BJ, CF, CG, CI, CM, GA, GN, GQ, GW, KM, ML, MR, NE, SN, TD, TG).

(54) Title: POWERED HINGE MECHANISMS



(57) Abstract: A device can include a hinge mechanism rotatably coupling a first portion of the device to a second portion of the device. The hinge mechanism is configured to automatically open the device. The device can also include a damper configured to control a rate at which the hinge mechanism automatically opens the device. The hinge mechanism can include a spine hinge, a rolling contact hinge, a film hinge, or a geared link hinge.

**Published:**

— *with international search report (Art. 21(3))*

## Description

### Title of Invention: POWERED HINGE MECHANISMS

#### Technical Field

- [1] This disclosure relates to powered hinge mechanisms.

#### Background Art

- [2] A variety of different types of devices incorporate hinges that allow the devices to open and close. Examples of hinged devices include flip-style mobile phones, devices that have a cover or lid coupled to the body of the device through the hinge, and devices that fold in half about the hinge. Typically, a user manually pulls the hinged portions of the device apart using one's fingers to open the device.

#### Disclosure of Invention

##### Technical Problem

- [3] Provided are powered hinge mechanisms capable of automatically opening the device.

##### Solution to Problem

- [4] One or more embodiments are directed to a device. In an aspect, a device can include a hinge mechanism rotatably coupling a first portion of the device to a second portion of the device. The hinge mechanism is configured to automatically open the device. The device can also include a damper configured to control a rate at which the hinge mechanism automatically opens the device. The hinge mechanism can include a spine hinge, a rolling contact hinge, a film hinge, or a geared link hinge.
- [5] One or more embodiments are directed to a method. In an aspect, a method can include providing a hinge mechanism rotatably coupling a first portion of a device to a second portion of the device. The hinge mechanism is configured to automatically open the device. The method can also include providing a damper configured to control a rate at which the hinge mechanism automatically opens the device. The hinge mechanism can include a spine hinge, a rolling contact hinge, a film hinge, or a geared link hinge.
- [6] This Summary section is provided merely to introduce certain concepts and not to identify any key or essential features of the claimed subject matter. Many other features and embodiments of the invention will be apparent from the accompanying drawings and from the following detailed description.

##### Brief Description of Drawings

- [7] The accompanying drawings show one or more embodiments; however, the accompanying drawings should not be taken to limit the invention to only the embodiments shown. Various aspects and advantages will become apparent upon review

of the following detailed description and upon reference to the drawings.

- [8] FIGs. 1 and 2 are perspective cutaway views of a device with an example hinge mechanism.
- [9] FIGs. 3 and 4 are side, partial cutaway views of the device of FIGs. 1 and 2 including the example spine hinge.
- [10] FIG. 5 is a perspective cutaway view of a device including another example of a spine hinge.
- [11] FIG. 6 illustrates a cross-sectional side view the device of FIG. 5.
- [12] FIG. 7 is a perspective cutaway view of a device with another example hinge mechanism.
- [13] FIGs. 8A through 8E are cross-sectional side views of the device of FIG. 7.
- [14] FIG. 9 illustrates a perspective view of a device including another example hinge mechanism.
- [15] FIG. 10 is a cross-sectional side view of the device of FIG. 9.
- [16] FIG. 11 is a perspective view of a portion of the device of FIG. 9.
- [17] FIG. 12 illustrates rolling action of the device of FIG. 9 using the example magnetic rolling contact hinge.
- [18] FIG. 13 is a perspective cutaway view of a device including another example hinge mechanism.
- [19] FIGs. 14A through 14F are cross-sectional side views of the device of FIG. 13 illustrating 360-degree rotation using the film hinge.
- [20] FIG. 15 illustrates a perspective view of a device with another example film hinge.
- [21] FIG. 16 is a perspective cutaway view of a device including another example hinge mechanism.
- [22] FIGs. 17A through 17B are perspective cutaway views illustrating the example geared hinge of FIG. 16.
- [23] FIG. 18 is a perspective cutaway view of the example geared hinge of FIG. 16.
- [24] FIG. 19 is a perspective cutaway view of a device including another example geared hinge.
- [25] FIGs. 20A and 20D are perspective cutaway views of the geared hinge of FIG. 19.
- [26] FIG. 21 illustrates a perspective cutaway view of device including another example geared hinge.
- [27] FIGs. 22A and 22B are perspective cutaway views of the example geared hinge of FIG. 21.
- [28] FIG. 23 is a perspective cutaway view illustrating another example hinge.
- [29] FIG. 24 illustrates a method of manufacturing a device having a powered hinge mechanism.
- [30] FIGs. 25A and 25B illustrate an example of a cam/rocker position stop mechanism.

- [31] FIGs. 26A through 26D illustrate an example of a magnetic brake.
- [32] FIGs. 27A and 27B are side cutaway views illustrating another example of a spine hinge.

### **Mode for the Invention**

- [33] While the disclosure concludes with claims defining novel features, it is believed that the various features described herein will be better understood from a consideration of the description in conjunction with the drawings. The process(es), machine(s), manufacture(s) and any variations thereof described within this disclosure are provided for purposes of illustration. Any specific structural and functional details described are not to be interpreted as limiting, but merely as a basis for the claims and as a representative basis for teaching one skilled in the art to variously employ the features described in virtually any appropriately detailed structure. Further, the terms and phrases used within this disclosure are not intended to be limiting, but rather to provide an understandable description of the features described.
- [34] This disclosure relates to powered hinge mechanisms. In one or more embodiments, the hinge mechanism supports automatic opening of a device. The hinge mechanism is capable of providing the power or force necessary to automatically open a device. For example, the hinge mechanism is capable of opening the device when a latch maintaining the device in a closed position is released. Under power of the hinge mechanism, the device opens without the user having to expend any effort such as pulling the device apart by hand. In one or more embodiments, the hinge mechanism is capable of providing approximately 180 degrees of rotation. In particular embodiments, the hinge mechanism is capable of providing approximately 360 degrees of rotation.
- [35] In one or more embodiments, the hinge mechanism is incorporated into a device such as a portable computing device. As an illustrative and non-limiting example, the device may be a mobile phone. In one or more embodiments, the mobile phone includes a first portion coupled to a second portion through the hinge mechanism. In an aspect, each of the two portions may include or incorporate a display screen. While a mobile phone is provided as an example of a device that includes a hinge mechanism as described herein, it should be appreciated that the example embodiments described within this disclosure may be incorporated within any of a variety of different types of devices. For example, a hinge mechanism as described herein may be used to couple a housing of a device to a lid or couple an additional display to a housing or other structure that may or may not include a display.
- [36] Further aspects of the inventive arrangements are described below in greater detail with reference to the figures. For purposes of simplicity and clarity of illustration,

elements shown in the figures are not necessarily drawn to scale. For example, the dimensions of some of the elements may be exaggerated relative to other elements for clarity. Further, where considered appropriate, reference numbers are repeated among the figures to indicate corresponding, analogous, or like features.

- [37] FIGs. 1 and 2 are perspective cutaway views of a device 100 with an example hinge mechanism. In the examples of FIGs. 1 and 2, the hinge mechanism is a spine hinge. Referring to FIGs. 1 and 2 collectively, a device 100 has a portion 102 and a portion 104. Each of portions 102 and 104, for example, may be a portion of the body of device 100. Portion 102 has a surface 106 and a surface 108. Portion 104 has a surface 110 and a surface 112. In the closed position, surface 108 is in contact with surface 110 forming an angle of 0 degrees or approximately 0 degrees.
- [38] In the example of FIGs. 1 and 2, portion 102 and portion 104 are coupled by a hinge mechanism that includes a hinge 114 and a spine 116. Portion 102 is capable of rotating around portion 104 about an axis of rotation defined by hinge 114. In the closed position, device 100 resembles a closed book with spine 116 covering hinge 114 similar to a spine of a book covering the binding of the book. Spine 116 has an edge 118 that is attached to an edge of portion 102. In an embodiment, edge 118 is attached, e.g., fixedly attached, to surface 106. Edge 118 may be attached using an adhesive, fasteners, a bonding process, or other suitable attachment mechanism or process.
- [39] In one or more embodiments, spine 116 is coupled to a spring 120 and a damper 122. Spring 120 and damper 122 are located within a channel 124 that resides within portion 104. Spring 120 and damper 122 are oriented parallel to the plane formed by surface 112 and perpendicular to edge 118 of spine 116 and to the edge of spine 116 that is opposite edge 118. In particular embodiments, spring 120 is included in the hinge mechanism. Spring 120 provides the force necessary to automatically open device 100. Damper 122 is capable of providing a dampening force that opposes the force exerted by spring 120. In the example of FIGs. 1 and 2, damper 122 is implemented as a linear damper. In one or more embodiments, damper 122 has a twin tube structure. Further, damper 122 may be pneumatic or hydraulic.
- [40] Referring to the example of FIGs. 1 and 2, damper 122 has a damper base 126 and damper member 128. Damper base 126 may be implemented as an outer tube that is attached to portion 104 within channel 124. Damper base 126 has an end that is capable of receiving damper member 128. Damper member 128 may be implemented as a piston, for example. Damper member 128 is moveable into and out of damper base 126. An end of damper member 128 that remains outside of damper base 126 is attached to a fastener 130. Fastener 130 is attached to spine 116, e.g., the edge of spine 116 opposite edge 118. Spring 120 is coupled to damper 122. For example, a first end of spring 120 is attached to damper base 126. A second end of spring 120 is coupled to

damper member 128. Accordingly, damper 122 is capable of controlling the rate at which spring 120 is able to open device 100. For example, the rate at which device 100 opens is controlled by the dampening effect generated by damper 122 countering the force exerted by spring 120.

[41] When device 100 is in the closed position with surface 108 in contact with surface 110, spring 120 is extended so as to exert sufficient force to open device 100. Device 100, for example, can include a latch (not shown) that maintains device 100 in the closed position. When the latch is released, device 100 opens due to the force exerted by spring 120. In the closed position, spine 116 is largely external to portion 104. A small portion of spine 116 is within a track formed within portion 104, which is revealed in the cut-away view of FIGs. 1 and 2. In response to the latch being released, spring 120 pulls spine 116 down the track within portion 104 in the direction of arrow 132. Spring 120 draws spine 116 deeper within the track. As spine 116 is drawn deeper within the track, the portion of spine 116 within the track maintains an orientation that is substantially parallel to surface 112.

[42] In the example of FIGs. 1 and 2, two damper/spring assemblies are shown. Each damper/spring assembly is located in a dedicated channel. In another embodiment, a single damper/spring assembly may be used. In that case, channel 124 may be located at a position that is approximately midway between the two channels illustrated in FIGs. 1 and 2. In another embodiment, three or more damper/spring assemblies may be used. For example, in cases where three or more damper/spring assemblies are used, each such assembly may be located in a different channel and the channels may be spaced approximately equidistant from one another.

[43] Referring to FIG. 1, device 100 is shown in an open position with the spine hinge forming an angle less than 90 degrees. The spine hinge is retractable. Referring to FIG. 2, device 100 is shown in an open position so that the spine hinge forms an angle greater than 90 degrees. In the example of FIGs. 1 and 2, device 100 is capable of opening to an angle of approximately 180 degrees as measured from surface 108 to surface 110.

[44] Example materials for implementing portions 102 and 104 include, but are not limited to, plastic, metal, ceramic, and other suitable materials. Example materials for implementing spine 116 include, but are not limited to plastic, metal sheeting, metal mesh, fabric, and other suitable materials. For example, spine 116 is flexible so as to bend as illustrated in FIGs. 1 and 2 to support 180-degree rotation. Still, spine 116 is also capable of maintaining a general shape or form (e.g., curvature) as illustrated in FIGs. 1 and 2.

[45] FIGs. 3 and 4 are side, partial cutaway views of device 100 of FIGs. 1 and 2 with the example spine hinge. In the example of FIG. 3, device 100 is in a closed position and is

viewed from the side. Edge 118 of spine 116 is attached to portion 102 within a slot extending inside of portion 102. Spine 116 is also within the track of portion 104. In the example of FIG. 3, a side covering 302 is added to each side of device 100 to close off the area between spine 116 and hinge 114. In one or more embodiments, side covering 302 is implemented as a bellows. Side covering 302 is capable of expanding when device 100 is in the closed position as illustrated in FIG. 3. When in an open position as illustrated in FIG. 4, side covering(s) 302 is capable of collapsing, e.g., folding, between the respective ends of portions 102 and 104 beneath hinge 114. Side cover 302 is capable of providing support for spine 116 so that spine 116 maintains a desired curvature at least while device 100 is in the closed position.

[46] Spine 116 is capable of bridging between portion 102 and portion 104. Spine 116 is positioned opposite hinge 114, e.g., as a fulcrum. As device 100 opens from the closed position, spine 116 retracts into portion 104. As device 100 closes from an open position, spine 116 withdraws from portion 104.

[47] In one or more embodiments, side covering 302 may be an outer covering. In that case, device 100 may have another internally sealed volume within side covering 302 and spine 116. The internally sealed volume may be water tight and is capable of connecting the edges of portions 102 and 104. Side covering 302 may be external. In one or more embodiments, side covering 302 provides further protection to the internally sealed volume. In particular embodiments, side covering 302 is capable providing an improved esthetic to device 100. As an illustrative and non-limiting example, within side covering 302 and spine 116, device 100 can have a water tight bellows or a flexible membrane connecting, e.g., attached to, end 304 of portion 104 and end 306 of portion 106. The water tight region, for example, may allow electrical wires to pass between portion 102 and portion 104.

[48] FIG. 5 is a perspective cutaway view of device 100 including another example of a spine hinge. FIG. 6 illustrates a cross-sectional side view of the example spine hinge of FIG. 5. Referring to FIGs. 5 and 6 collectively, the spine hinge is capable of providing 360 degrees or approximately 360 degrees of rotation. Further, a hinge (e.g., hinge 114) is not included to facilitate the 360 degrees of rotation. The example of FIGs. 5 and 6 includes an additional spine 502. Spine 502 is attached in an opposing manner compared to spine 116. For example, whereas spine 116 has edge 118 attached to portion 102, spine 502 has an edge 504 attached to portion 104.

[49] As illustrated in FIG. 6, edge 504 is attached to a surface of portion 104 located within a slot within portion 104. Spine 502 is coupled to a spring/damper assembly 506 within a channel 508 of portion 102. Spine 502 may be coupled to one or more spring/damper assemblies 506 as described with reference to spring 120 and damper 122 of FIGs. 1-4. It should be appreciated that the particular configuration of spring/damper

assembly 506 and number of such assemblies may be implemented to match the spring/damper assembly and number of such assemblies in portion 104. For example, as the cross-section of FIG. 6 illustrates, spring/damper assembly 506 may be aligned below the spring 120 and damper 122 assembly in portion 104.

[50] Accordingly, in the closed position, spine 116 is substantially extracted from portion 104, while spine 502 is substantially retracted within portion 102. In the 180-degree open position illustrated in FIG. 6, both spine 116 and spine 502 are substantially retracted. As device 100 is rotated beyond the 180-degree open position of FIG. 6, spine 502 is pulled from channel 508 so that spine 502 is substantially extracted from portion 102, while spine 116 is substantially retracted within portion 104.

[51] In the examples of FIGs. 1-6, one end of the spines is fixedly attached to one of the portions of device 100. In the examples shown, the spines are attached within slots in the portions. In particular embodiments, the spines can be fixedly attached to the outer surface of the appropriate portion. For example, spine 502 can be coupled to surface 110 of portion 104, while spine 116 is attached to surface 106 of portion 102. Spines 116 and/or 502 may be fixedly attached to one of portions 102 or 104 as the case may be using any of a variety of suitable attachment mechanisms. Further, spines 116 and/or 502 may be fixedly attached to any of a variety of locations on portion 102 or 104, as the case may be.

[52] FIG. 7 is a perspective cutaway view of device 100 with another example of a hinge mechanism. In the example of FIG. 7, the hinge mechanism is a rolling contact hinge. FIGs. 8A through 8E, are cross-sectional side views of the device of FIG. 7. Referring to FIGs. 7 and 8 collectively, device 100 has a rolling contact hinge that includes linkages 702 and 704. In particular embodiments, the ends of portions 102 and 104 are curved or rounded. For example, the ends of portions 102 and 104 may be hemi-cylindrical as opposed to other shapes such as rectangular as pictured in FIGs. 1-6. Linkage 702 includes pins 706 and 708. Linkage 704 includes pins 710 and 712. Pins 706 and 710 are engaged by portion 102, e.g., holes or a circular shaped channel within portion 102. Pins 708 and 712 are engaged by portion 104. In the example of FIGs. 7 and 8, portion 102 is capable of rotating about an axis formed by pins 706 and 710. Portion 104 is capable of rotating about a second axis of rotation formed by pins 708 and 712.

[53] The rolling contact hinge of FIG. 7 and FIG. 8A through FIG. 8E further includes a plurality of straps 714, 716, 718, and 720. An additional strap may be included adjacent to strap 716 on the opposite side of strap 718, but is not pictured so as to avoid obscuring the view of other components. In the example shown, the number of straps is for purposes of illustration only. In one or more embodiments, the straps may be narrower in width thereby allowing more straps to be included. In one or more em-

bodiments, fewer straps may be used. For example, two straps may be used. Straps 714-720 are interleaved and provide for motion control as described herein in greater detail in connection with FIG. 8A through FIG. 8E.

- [54] In one or more embodiments, straps 714-720 are implemented as a flexible material. In an example, straps 714-720 are implemented as a flexible film. Example materials from which straps 714-720 may be implemented include, but are not limited to, plastic, fabric, or other suitable materials.
- [55] As pictured, each strap is attached to a first surface of portion 102 and an opposing surface of portion 104. In FIG. 7, for example, device 100 is in an open position with an angle of approximately 180 degrees. As shown, strap 714 has a first end attached to surface 112 (bottom) of portion 104 and a second end attached to surface 108 (top) of portion 102. Strap 716 has a first end attached to surface 110 (top) of portion 104 and a second end attached to surface 106 (bottom) of portion 102. Strap 714 and strap 716 cross one another when viewed from the side of device 100. Strap 718 is attached the same way that strap 714 is attached. Strap 720 is attached the same way that strap 716 is attached. Thus, straps 714-720 effectively alternate in the way in which each strap attaches to portion 102 and 104 of device 100.
- [56] The terms "top" and "bottom," at least with reference to attachment of straps, are used in reference to the particular orientation and angle of rotation of device 100 shown in FIG. 7. When device 100 is in a closed position, for example (as pictured in FIG. 3), surface 106 is facing outward as is surface 112, with surfaces 108 and 110 in contact with one another. Thus, the particular surface considered the "top" or "bottom" depends upon the angle of rotation of the hinge mechanism formed by portion 102 and portion 104.
- [57] In the example of FIGs. 7 and FIG. 8A through FIG. 8E, springs 722 and 724 are included. Springs 722 and 724 may be implemented as torsional coil springs that are capable of providing the force necessary for device 100 to open automatically. A damper 726 is included. Damper 726 may be implemented as a cylindrical damper. In the example shown, pin 708 extends through damper 726. Damper 726 controls the rate at which device 100 opens from the force provided by springs 722 and 724.
- [58] In particular embodiments, pin 706 is fixedly attached, or part of, linkage 702. Pin 710 is fixedly attached, or part of, linkage 704. For example, pin 706 may be integrated into linkage 702. Pin 710 can be integrated into linkage 704. As an illustrative and non-limiting example, pin 706 (710) and linkage 702 (704) can be a single, unified structure. Pin 708 is received by an aperture or hole in linkage 702. For example, pin 708 may snap into position as received by linkage 702. Further, pin 708 passes through spring 722 and damper 726. Pin 712 is received by an aperture or hole in linkage 704. For example, pin 712 may snap into position as received by linkage 704. Further, pin

712 passes through spring 724.

- [59] FIG. 8A through FIG. 8E, taken collectively, illustrate the action of the rolling hinge as device 100 is opened. As device 100 opens (e.g., or closes), one strap (or set of straps) unwinds, while the other strap (or set of straps) winds, thereby maintaining a substantially constant length relationship and ensuring synchronous movement. Because the two straps (or two sets of straps e.g., where straps 714 and 718 form one set and straps 716 and 720 form another set) do not change in length and lay flat on the hemi-cylindrical surfaces of portions 102 and 104, the straps do not allow the hemi-cylindrical surfaces to slip relative to each other. The hemi-cylindrical surfaces of portions 102 and 104 are constrained to roll in the same way that two meshing gears are constrained. As such, straps 714-720 exhibit a gear-like behavior. The rigid link provided by linkages 702 and 704 prevents portions 102 and 104 from separating. Straps 714-720 also help to prevent portions 102 and 104 from separating.
- [60] FIG. 8A through FIG. 8E illustrate that straps 714-720 facilitate rolling contact between the end of portion 102 and the end of portion 104. While the two ends of portions 102 and 104 roll about one another, neither end comes into direct contact with the other since the straps 714-720 are between the ends to facilitate smooth and synchronized rolling. Each of the ends 304 and 306 of portion 102 and portion 104, respectively, that abut are rounded or curved to facilitate smooth rolling contact throughout the 360 degrees of rotation provided. Ends 304 and 306 may have the same curvature to facilitate a smooth rolling effect. As discussed, in one or more embodiments, end 304 of portion 102 and end 306 of portion 104 may be hemi-cylindrical. Accordingly, in the example of FIG. 8A through FIG. 8E, strap 714 is unwinding from portion 104, while strap 716 is winding around portion 104.
- [61] In one or more embodiments, linkages 702 and 704 are configured to allow electrical wires to pass through. For example, one or more wires carrying power and/or data signals may be routed through either one or both of linkages 702 and 704. Thus, data signals and/or power signals are able to pass from electronics within portion 102 to electronics within portion 104. In particular embodiments, one linkage is capable of carrying power signals, while the other linkage is capable of carrying data signals. In particular embodiments, one or both of linkages 702 and/or 704 are capable of carrying both data signals and power signals.
- [62] In one or more embodiments, straps 714-720 are configured to include wires carrying data signals and/or power signals. As an illustrative and non-limiting example, one or more or all of straps 714-720 may be implemented using flexible circuitry. In another illustrative and non-limiting example, straps 714-720 may be implemented using fabric or flexible plastic where one or more wires are attached (e.g., glued or bonded) to the fabric and/or flexible plastic.

- [63] FIG. 9 illustrates a perspective view of device 100 including another example hinge mechanism. In the example of FIG. 9, the hinge mechanism is a magnetic rolling contact hinge. Referring to FIG. 9, portion 102 has a rounded end 304. Portion 104 has a rounded end 306. In the example of FIG. 9, rounded ends 304 and 306 have the same curvature to facilitate a smooth rolling effect. For example, rounded ends 304 and 306 each may be hemi-cylindrical.
- [64] Portion 102 includes a magnet array 906 and a magnet array 910. Portion 104 includes a magnet array 908 and a magnet array 912. Each magnet array may be formed of a plurality of magnets arranged adjacent to one another as pictured. In one or more embodiments, magnet arrays 906-912 are arranged in a helix or partial helix formation. For example, magnet array 906 and magnet array 910 each is arranged as a right-handed helix. Magnet array 908 and 912 each is arranged as a left-handed helix. Magnetic arrays 906-912 may be fixedly attached to ends 304 and 306 using an adhesive or other suitable attachment mechanism.
- [65] Rounded end 304 and rounded end 306 are able to roll about one another while maintaining synchronization using magnet arrays 906-912. For example, magnet array 906 and magnet array 908 may be aligned so that opposite poles align across from one another as the rolling motion occurs. Similarly, magnet array 910 and magnet array 912 may be aligned so that opposite poles align across from one another as the rolling motion occurs.
- [66] In the example of FIG. 9, magnetic arrays 906-910 are provided for synchronizing rotation of portions 102 and 104. It should be appreciated that further structure such as linkages (with pins), dampers, and springs as described with reference to FIGs. 7 and 8 may also be included. As an illustrative and non-limiting example, magnetic arrays 906-910 may be used in place of the straps in the examples of FIGs. 7 and 8 to implement a magnetic rolling contact hinge for device 100. In one or more other embodiments, magnet arrays 906-910 may also provide damping so that a separate or discrete damper is not required.
- [67] FIG. 10 is a cross-sectional side view of the device of FIG. 9. FIG. 10 illustrates an example implementation of the magnet arrays of FIG. 9. In the example of FIG. 10, portions 102 and 104 are shown in cross-section. As rounded end 304 and rounded end 306 roll on one another, magnetic array 906 aligns with magnet array 908 so that north poles of magnet array 906 are aligned with south poles of magnet array 908. Similarly, south poles of magnet array 906 are aligned with north poles of magnet array 908.
- [68] FIG. 11 is a perspective view of portion 102 and magnet arrays 906 and 910. FIG. 11 illustrates the helix shape formed by magnet arrays 906 and 910 within portion 102.
- [69] FIG. 12 illustrates rolling action facilitated by the magnetic rolling contact hinge. In the example of FIG. 12, magnet array 910 and magnet array 912, each being at least

partially helical and being opposite in terms of handedness, facilitate synchronization of portion 102 and portion 104 as rounded ends 304 and 306 roll about one another.

[70] In the example embodiments illustrated in FIGs. 9-12, it should be appreciated that rounded ends 304 and 306 of portion 102 and portion 104, respectively, are made using a magnetically permeable material. In one or more embodiments, rounded ends of portions 102 and 104 are made of a non-ferrous material. In one or more embodiments, rounded ends of portions 102 and 104 are made of other materials such as, for example, plastics, glass, aluminum, polychlorinated biphenyl (PCB), or other suitable materials.

[71] In the examples described in connection with FIGs. 9-12, the magnets in each of the magnet arrays are arranged adjacent to one another. For example, the magnets in magnet array 910 abut one another. Further, the particular shape of each magnet array need not be a helix or partial helix. In one or more other embodiments, magnets of a magnet array may be spaced apart within approximately 20-30 degrees of rotation so long as magnets in magnet array 910 (906) are paired with magnets in magnet array 912 (908), e.g., with opposing poles, so that magnets on one side (e.g., in one portion) are looking for a paired magnet on the other side (e.g., in the other portion).

[72] In one or more other embodiments, each of magnet arrays 906-912 may be implemented as a polymagnet as opposed to an array of discrete magnets. In particular embodiments, a strip corresponding to the surface of attachment of each of magnet arrays 906-912 on rounded edges 902 and 904 may be magnetized as a polymagnet to provide the synchronization described. As such, separate magnetic structures are not needed since portions or strips of rounded ends 304 and 306 are capable of being magnetized as polymagnets to perform the functionality described in connection with FIGs. 9-12 to facilitate the rolling contact described.

[73] FIG. 13 is a perspective cutaway view of device 100 including another example hinge mechanism. In the example of FIG. 13, the hinge mechanism is implemented as a film hinge. In the example of FIG. 13, portion 102 is coupled to portion 104 by a film 1302. In one or more embodiments, film 1302 is pleated. For example, film 1302 may have one or more folds. The folds, or pleats, are parallel to an axis of rotation 1304 about which portion 102 rotates. Linkage 1308 has a pin 1306 and a pin 1316. Linkage 1312 has a pin 1310 and pin 1318. Linkage 1308 and 1312 may be implemented substantially similar to linkages 702 and 704, respectively, of FIGs. 7 and 8. In the example of FIG. 13, however, pins 1316 and 1318 slide within slots 1320 and 1322, respectively.

[74] Pin 1306 passes through spring 1314. In one or more embodiments, pin 1306 passes through damper 1324. In particular embodiments, pin 1306 passes at least partially through damper 1324. Damper 1324 may be implemented as a cylindrical damper. Pin

1310 passes through spring 1326. Springs 1314 and 1326 may be implemented as torsional coil springs. As pictured, pins 1306, spring 1314, damper 1324, spring 1326, and pin 1310 are aligned along axis of rotation 1304. Portion 104 is capable of rotating around axis of rotation 1304. Portion 102 is capable of rotating around a second axis of rotation aligned with pins 1316 and 1318.

[75] Linkage 1308 is coupled to pin 1316. In an embodiment, pin 1316 is attached to linkage 1308. In another embodiment, linkage 1308 is formed with pin 1316 as an integrated part of linkage 1308, e.g., as a single, unified structure. Linkage 1312 is coupled to pin 1318. Linkage 1312 may be coupled to pin 1318 as described in connection with linkage 1308 and pin 1316. Pin 1316 is inserted into a slot 1320 positioned along a side of portion 102. Pin 1318 is inserted into a slot 1322 positioned along a side of portion 102 opposing the side with slot 1320.

[76] In the example of FIG. 13, the film hinge is opened, e.g., powered, by springs 1314 and/or 1326. Springs 1314 and 1326 are capable of providing the force used to automatically open device 100. Damper 1324 provides dampening and is capable of controlling the rate at which device 100 opens. In one or more embodiments, film 1302 is folded into layers to allow approximately 180 degree or 360-degree rotation. As illustrated, one side of each of linkages 1308 and 1312, e.g., pins 1316 and 1318, slide in slots 1320 and 1322, respectively, while device 100 opens and/or closes. Pins 1316 and 1318, for example, slide in slots 1320 and 1322 due to the changes in distance created by portion 102 rotating around an axis that is removed from the plane of the linkage, e.g., axis of rotation 1304.

[77] FIGs. 14A through 14F are cross-sectional side views of the device of FIG. 13 that, taken collectively, illustrate 360-degree rotation using the film hinge. In FIG. 14-1, device 100 is in a closed position. In the closed position, film 1302 has a fold 1402. Fold 1402 has an angle of approximately zero degrees. Linkage 1308 is oriented with an angle of approximately 45 degrees relative to portion 104. Pin 1316 (not shown) of linkage 1308 is toward the far right of slot 1320.

[78] In FIG. 14B, device 100 begins to open. As pictured, pin 1316 of linkage 1308 has slid from one end of slot 1320 to the other end. Further, film 1302 develops a second fold 1404. The angle of fold 1404 in FIG. 14B is greater than 90 degrees.

[79] FIGs. 14C and 14D illustrate continued rotation of portion 102 about axis of rotation 1304 (not shown), which corresponds to pin 1306. As illustrated, the size of the angle of fold 1404 has reduced from FIG. 14B to FIG. 14C and continues to become smaller to virtually zero degrees in FIG. 14D. The angle of fold 1402 begins to increase in FIG. 14D.

[80] In FIG. 14E, the angle of fold 1402 continues to increase. Further, pin 1316 (not shown) of linkage 1308 remains in the same position in slot 1320 as in each of FIGs.

14B, 14C, and 14D.

- [81] In FIG. 14F, the angle of fold 1402 increases to approximately 180 degrees and is therefore not visible as a fold. In FIG. 14F, device 100 is completely open. Whereas surfaces 106 and 112 of portions 102 and 104, respectively, are facing outward when device 100 is in the closed position in FIG. 14A, surfaces 106 and 112 are in contact with one another in the fully open position of FIG. 14F. Similarly, while surfaces 108 and 110 are in contact with one another when device 100 is in the closed position illustrated in FIG. 14A, surfaces 108 and 110 are facing outward, e.g., in opposite directions, when device 100 is in the fully open position illustrated in FIG. 14F.
- [82] In one or more embodiments, film 1302 is made of a plastic material. The plastic material may be one that is suitable for being drawn into films. The plastic material may be highly cyclable. In one example, film 1302 may be made of polypropylene. In one or more embodiments, film 1302 is made of a fabric.
- [83] In one or more embodiments, electrical signals may be routed from electronics located in portion 102 to electronics in portion 104 using wires that flow through linkage 1308 and/or linkage 1312. In one or more embodiments, electrical signals may be conveyed wirelessly between electronics in portion 102 and electronics in portion 104.
- [84] FIG. 15 illustrates a perspective view of device 100 with another example film hinge. In the example of FIG. 15, springs, dampers, and linkages are not shown. FIG. 15 illustrates an example embodiment in which apertures 1505 are created within the folds of film 1302 to allow one or more wires 1510 to pass from electronics in portion 102 to electronics located in portion 104. In one or more embodiments, wires 1510 are implemented as a ribbon cable. As pictured, each of portions 102 and 104 may also have an aperture 1515 or opening through which wires 1510 are able to pass. In one or more embodiments, openings in portions 102 and 104 through which wire 1510 passes may have a gasket, a membrane, or other material sealing the opening. As such, aperture 1515 in portions 102 and 104 through which wire 1510 passes may be waterproof or substantially waterproof.
- [85] FIG. 16 is a perspective cutaway view of device 100 including another example hinge mechanism. In the example of FIG. 16, the hinge mechanism is a geared hinge. In the example of FIG. 16, device 100 includes linkage 1602, linkage 1604, a damper 1606, springs 1608, 1610, 1612, and 1614, and motion control gears 1616, 1618, 1620, and 1622. Damper 1606 is implemented as a cylindrical damper. Springs 1608, 1610, 1612, and 1614 may be implemented as torsional coil springs.
- [86] In one or more embodiments, motion control gears 1616, 1618, 1620, and 1622 are integrated into portion 102 and portion 104 of device 100. For example, rather than including gears within linkages 1602 and/or 1604, gearing may be incorporated into

portions 102 and 104 themselves.

[87] FIGs. 17A through 17B are perspective cutaway views illustrating the example geared hinge of FIG. 16. Referring to FIGs. 17A and 17B, motion control gears 1620 are shown. In the example of FIG. 17A, device 100 is in an open position with an angle of approximately 180 degrees. Motion control gears 1620 include a plurality of geared members. For example, motion control gears 1620 include a geared member 1702 and a geared member 1704. Geared member 1702 includes an arm that extends into portion 102. Geared member 1704 includes an arm that extends into portion 104. Geared member 1702 and geared member 1704 each include teeth, or gears, that cooperatively engage one another to synchronize motion of portions 102 and 104 when device 100 opens and closes.

[88] In the example of FIG. 17A, geared members 1702 and 1704 are shown. In one or more embodiments, another set of geared members may be located on the far side of linkage 1602. Referring to FIG. 16, for example, each of linkages 1602 and 1604 can include a pair of geared members 1702, 1704 on each side to facilitate synchronized and steady opening and closing of device 100.

[89] In one or more embodiments, the arm of geared member 1702 is fixedly attached to portion 102. Similarly, the arm of geared member 1704 is fixedly attached to portion 104. In one or more embodiments, geared member 1702 is an integrated part of portion 102 and geared member 1704 is an integrated part of portion 104. In one or more embodiments, the arm of geared member 1702 extends into and is received by a cavity of portion 102 providing a snug and/or secure fit therein. Similarly, the arm of geared member 1704 extends into and is received by a cavity of portion 104 providing a snug and/or secure fit therein. In any case, geared members 1702 and 1704 synchronize movement of portions 102 and 104 as device 100 opens and closes.

[90] Linkage 1602 includes two pins 1706 and 1708. In one or more embodiments, pins 1706 and 1708 are formed as part of linkage 1602. For example, pins 1706 and 1708 are fixedly attached to linkage 1602 so as not to rotate. In one or more embodiments, pins 1706 and 1708 are capable of rotating within linkage 1602. As shown, geared member 1702 includes an aperture that is configured to receive pin 1706. Geared member 1704 includes an aperture that is configured to receive pin 1708.

[91] FIG. 17B illustrates an example implementation of linkage 1602. As pictured, linkage 1602 is substantially hollow and includes pins 1706 and 1708 extending therethrough to engage geared members 1702 and 1704 (not shown). As pictured, spring 1608 is wound around pin 1706. Spring 1610 is wound around pin 1708. Spring 1608 extends into portion 102. Spring 1610 extends into portion 104. Springs 1608, 1610, 1612, and 1614 provide the force necessary to automatically open device 100.

[92] FIG. 18 illustrates a cut-away perspective view of the example geared hinge of FIG.

16. FIG. 18 illustrates a close-up view of the contents within linkage 1602. In the example of FIG. 18, linkage 1602 is located between motion control gears 1616 and 1618. In this regard, pin 1806 extends through linkage 1602 to be received by each of geared members 1702 and 1802. Pin 1708 extends through linkage 1602 to be received by each of geared members 1804 and 1704. In the examples of FIG. 16, 17A, 17B and 18, pin 1706 is aligned with a first axis of rotation, while pin 1708 is aligned with a second axis of rotation. In the example of FIG. 18, pin 1708 may extend past geared member 1804 and extend through or partially through or connect to damper 1606. Damper 1606 is capable of controlling the rate at which device 100 opens by countering the force provided by the springs. As pictured, the arms of the geared members extend into a cavity in each respective portion as does each end of springs 1610 and 1608. The structure of linkage 1604 (e.g., geared members, springs, and pins) may be implemented substantially similar to the example of linkage 1602 described in connection with FIG. 18.

[93] FIG. 19 is a perspective cutaway view of a device including another example geared hinge. The geared hinge illustrated in FIG. 19 is substantially similar to the embodiments described in connection with FIG. 16. In the example of FIG. 19, a belt drive mechanism is used in place of the linkage and spring assembly. In the example of FIG. 19, device 100 includes springs 1902 and 1904, a damper 1906, belt and pulley assemblies 1908 and 1910, and motion control gears 1912 and 1914. Damper 1906 is implemented as a cylindrical damper. Damper 1906 is capable of controlling the rate at which device 100 opens. Springs 1902 and 1904 may be implemented as torsional coil springs. In the example of FIG. 19, device 100 is in an open position with an angle of approximately 180 degrees between portion 102 and portion 104.

[94] FIGs. 20A and 20D are perspective cutaway views of the geared hinge of FIG. 19. Referring to FIG. 20A and 20D, belt and pulley assembly 1908 has a casing 2002 and pins 2004 and 2006. Pin 2004 is aligned with a first axis of rotation. Pin 2006 is aligned with a second axis of rotation. Belt and pulley assembly 1908 includes a drive wheel 2008, a pulley 2020, and a belt 2010. A first end of belt 2010 is attached to drive wheel 2008. Drive wheel 2008 is coupled to pin 2006. A second end of belt 2010 is attached to the inner portion of the channel of portion 102. Belt 2010 bends around pulley 2020, which is coupled or mounted to pin 2004. In one or more embodiments, drive wheel 2008 is fixed to pin 2006. Springs 1902 and 1904 provide the force that automatically opens device 100. Drive wheel 2008 is configured to wind belt 2010 as device 100 closes and unwind belt 2010 as device 100 opens. In the example of FIG. 20, device 100 further includes geared members 2012 and 2014 as described with reference to FIG. 16, though the geared members are at least partially obscured by belt and pulley assembly 1908. As illustrated in FIG. 20B, device 100 is capable of rotating

beyond 180 degrees. As noted, device 100 is capable of 360-degree rotation.

[95] The examples of FIGs. 20C and 20D illustrate the closing action of device 100. In the examples of FIG. 20C and 20D, device 100 closes as drive wheel 2008 winds belt 2010. Belt 2010 moves around pulley 2020 and, as illustrated in FIG. 20D, no longer contacts pulley 2020 when device 100 is moved into the closed position or an angle formed by portions 102 and 104 of approximately less than 90 degrees.

[96] FIG. 21 illustrates a perspective cutaway view of device 100 including another example geared hinge. The geared hinge illustrated in FIG. 21 utilizes a linkage with integrated gears. In one or more embodiments, the linkage is operable to provide damping through the inclusion of a fluid. As pictured, device 100 includes linkage 2102 and linkage 2104. In FIG. 21, linkage 2104 is removed in order to better illustrate the elements included within the linkage. Each of linkages 2102 and 2104 includes motion transfer gears 2106 and fixed gears 2108 and 2126. Further, the geared hinge includes springs 2110, 2112, 2114, and 2116.

[97] The geared hinge includes a pin 2118 that extends through linkage 2104 and spring 2110. Pin 2120 extends through linkage 2104, spring 2112, and fixed gear 2108. Pin 2122 extends through linkage 2102 and spring 2114. Pin 2124 extends through linkage 2102 and spring 2116. The geared hinge is powered by springs 2110-2116. For example, springs 2110 and 2114 may be torsional coil springs that provide rotational force for portion 102 to rotate around an axis of rotation aligned with pins 2118 and 2122. Springs 2112 and 2116 may be torsional coil springs that provide rotational force for portion 104 to rotate around an axis of rotation aligned with pins 2120 and 2124. Motion is controlled by motion transfer gears 2106 and fixed gears 2108 and 2126 within linkages 2102 and 2104. Motion transfer gears 2106 and fixed gears 2108 and 2126 synchronize the rotation between portion 102 and portion 104.

[98] In one or more embodiments, linkages 2102 and 2104 each include a gear compartment. The gear compartment may be sealed and filled with a fluid and/or a heavy grease. By tuning fixed gears 2108 and 2126 and motion transfer gears 2106 in combination with the fluid and/or heavy grease, dampening action is provided that is capable of controlling the rate at which device 100 opens.

[99] In one or more embodiments, one or both of linkages 2102 and 2104 may include a separate channel or pass-through (not shown) in a different plane than the sealed gear compartments. The channel may be sized to allow electrical wires or other connections to pass through from circuitry in portion 102 to circuitry in portion 104.

[100] FIGs. 22A and 22B are perspective cutaway views of the example geared hinge of FIG. 21. Referring to FIGs. 22A and 22B, pin 2118 extends through linkage 2104 and fixed gear 2126. Fixed gear 2126 engages with motion transfer gears 2106. Pin 2120 extends through linkage 2104 and fixed gear 2108. Fixed gear 2108 engages with

motion transfer gears 2106.

[101] FIG. 23 is a perspective cutaway view illustrating another example hinge mechanism. As pictured, the hinge mechanism includes a housing 2302. In one or more embodiments, element 2304 is a ribbon cable illustrating one example for coupling circuitry in portion 102 with circuitry in portion 104.

[102] In one or more other embodiments, element 2304 is a torsional leaf spring. As a torsional leaf spring, element 2304 is capable of providing force needed to open device 100. In the example of FIG. 23, other structures such as pins and dampers are not shown to more clearly illustrate element 2304. In particular embodiments, two or more of elements 2304 may be included and pass through housing 2302 where one or more of elements 2304 are torsional leaf springs and one or more of elements 2304 are ribbon cables. Thus, both a torsional leaf spring and a ribbon cable may pass through housing 2302 to provide communication between circuitry in portions 102 and 104 and also to provide force that automatically opens device 100.

[103] In one or more embodiments, a torsional leaf spring as illustrated in FIG. 23 may be incorporated into device 100 in the example of FIGs. 1-6 where spine(s) are used. The torsional leaf spring (or springs) may be used to provide further rotational force for automatically opening device 100.

[104] The example embodiments described herein can include a latch that keeps device 100 in the closed position until the latch is released. The latch may be implemented as any of a variety of different latch types. Example latch types include, but are not limited to, magnetic, electromagnetic, mechanical, magnetic/mechanical, and electromechanical. The particular type of latch included in device 100 is not intended to limit the example embodiments described herein.

[105] In one or more embodiments, the latch is configured to release in response to successful user authentication. For example, device 100 may include a fingerprint sensor, voice/speaker recognition, eye/facial scanning, receive an input password or gesture via an externally accessible touch pad or touch sensitive surface, via near field communication (NFC) tag, or a handshake with another device such as a smart watch or another portable device or appliance.

[106] An example of a magnetic latch may be implemented using printed magnets. A first magnet may be printed on surface 108 of portion 102 and a second magnet printed on surface 110 of portion 104. The two magnets may be located and/or positioned so as to come in contact with one another when device 100 is in the closed position. The poles of each printed magnet may be aligned when device 100 is in the closed position so as to attract one another thereby keeping device 100 in the closed position. The attractive force of the latch, for example, is sufficient to overcome the forces provided for automatic opening of the hinge mechanism and device 100.

- [107] One of the magnets may be printed on a surface or element that is configured to provide a small amount of movement. In response to movement of one of the printed magnets, e.g., when the latch is to open, the poles of the two printed magnets no longer align to provide attractive force and instead repel thereby releasing the latch. As an illustrative example, one of the magnets may be mechanically connected to a button or may be moved by a solenoid that is controlled by a manual control or a user authentication process (e.g., electronically).
- [108] The example embodiments described herein may include any of a variety of different types of dampers. In one or more embodiments, the dampers are passive mechanisms. Examples of passive dampers include hydraulic dampers (e.g., dampers that utilize oil) whether rotary or linear, and air dampers (e.g., linear). Other examples of passive dampers include miniature fly wheels, mechanical brakes, and patterned magnetic brakes.
- [109] In one or more embodiments, the dampers are active mechanisms. Examples of active mechanisms include magnetorheological fluid, solenoid clutch, and a motor and/or generator. A magnetorheological fluid, also referred to as a ferrofluid, may be used so that application of a magnetic field to the fluid changes the properties of the fluid to either increase or decrease damping. For example, a ferrofluid may be included within the linkages described with reference to FIGs. 21, 22A and 22B. Application of the magnetic field can increase and/or decrease damping. Increasing damping a sufficient amount allows the mechanism to provide one or more position stops. In the examples of FIGs. 21, 22A and 22B, a controller (e.g., a processor capable of executing program code or other suitable control circuitry) may be included that is capable of adjusting a magnetic field applied to the ferrofluid within the linkages so as to dynamically control damping and/or provide one or more position stops.
- [110] In particular embodiments, the controller is capable of controlling operation of an active damper used with the hinge mechanisms described herein. By controlling the amount of damping provided by an active damper such as a magnetorheological fluid, a solenoid clutch, a motor, or a generator, the controller is able to electronically control and vary the amount of damping provided. Thus, the damper is capable of providing a variable amount of damping to vary the rate of opening of device 100 under electronic control of the controller. Further, the controller is capable of controlling whether the active damper implements position stops and/or changing the angle at which position stops are implemented.
- [111] In one or more embodiments, the damping may be controlled, e.g., electronically controlled, based upon the position of device 100, the orientation of device 100, and the size of the angle formed by portion 102 and portion 104. In particular embodiments, position stops may be selectively implemented by the active damper under

control of the controller based upon position of device 100, the orientation of device 100, and/or the size of the angle formed by portion 102 and 104. It should be appreciated that a controller can be coupled to one or more sensors within device 100 such as accelerometers, gyroscopes, and other suitable motion sensors in order to detect position, orientation, and angle as described herein.

[112] In one or more embodiments, position stops may be incorporated into the hinge mechanisms. In particular embodiments, the position stop mechanisms are passive. Examples of passive position stop mechanisms include cam/rockers, mechanical brakes, patterned magnetic brakes, and flat surfaces on rounded ends (e.g., ends 304 and 306) of each of portions 102 and 104. The passive position stop mechanisms can be incorporated to provide one or more position stops in the rotational movement of the hinge mechanisms so that device 100 has resistance and stops the automatic rotation (or opening) at particular angles of rotation. In the case of the flat surfaces, the flat surface(s) can be located on the rounded ends 304 and 306 of portions 102 and 104 so that the flat surface of portion 102 contacts the flat surface of portion 104 through synchronized movement in example embodiments as described in connection with FIGs. 7, 8, 9, 10, 11, and 12.

[113] In one or more embodiments, elements such as cam/rockers and motors and/or generators may be used to provide position stops. The cam/rockers and motors and/or generators are examples of active position stop mechanisms. As noted, active dampers can be electronically controlled to provide a variable amount of damping under control of a controller.

[114] FIG. 24 illustrates a method 2400 of manufacturing a device having a powered hinge mechanism. Method 2400 can be performed to implement a device having a powered hinge mechanism as described herein.

[115] In block 2402, a hinge mechanism is provided. The hinge mechanism is capable of rotatably coupling a first portion of the device to a second portion of the device. The hinge mechanism is further capable of automatically opening the device. The hinge mechanism can include a spine hinge, a rolling contact hinge, a film hinge, or a geared link hinge. The hinge mechanism, whether implemented as a spine hinge, a rolling contact hinge, a film hinge, or a geared link hinge, may be implemented as an active open hinge.

[116] As an illustrative and non-limiting example, in the case of the spine hinge, a first retractable spine is provided. A second retractable spine is also provided that opposes the first retractable spine.

[117] As another illustrative and non-limiting example, in the case of the rolling contact hinge, a first strap is provided. The first strap is coupled to a top surface of the first portion and a bottom surface of the second portion. A second strap is provided. The

second strap is coupled to a bottom surface of the first portion and a top surface of the second portion. The first strap and the second strap facilitate rolling contact between a rounded end of the first portion and a rounded end of the second portion.

[118] As another illustrative and non-limiting example, the rolling contact hinge can be a magnetic rolling contact hinge. In the case of a magnetic rolling contact hinge, a first array of magnets is provided. The first array of magnets is arranged in a first formation within a rounded end of the first portion. A second array of magnets is provided. The second array of magnets is arranged in a second formation within a rounded end of the second portion. The second formation is capable of opposing the first formation. Further, corresponding points along the first array of magnets and the second array of magnets are capable of attracting to facilitate rolling contact between the rounded end of the first portion and the rounded end of the second portion. In particular embodiments, the first formation is at least a partial helix having a first handedness and the second formation is at least a partial helix having an opposing handedness.

[119] In another example, in the case of the magnetic rolling contact hinge, a first polymagnet is provided. The first polymagnet is implemented in a first formation within a rounded end of the first portion. A second polymagnet is provided. The second polymagnet is implemented in a second formation within a rounded end of the second portion. The second formation is capable of opposing the first formation. Further, corresponding points along the first polymagnet and the second polymagnet are capable of attracting to facilitate rolling contact between the rounded end of the first portion and the rounded end of the second portion. In particular embodiments, the first formation is at least a partial helix having a first handedness and the second formation is at least a partial helix having an opposing handedness.

[120] As another illustrative and non-limiting example, in the case of the film hinge, a film is provided. The film hinge is capable of joining the first portion with the second portion. The film has a plurality of folds parallel to an axis of rotation of the hinge mechanism.

[121] As another illustrative and non-limiting example, in the case of the geared link hinge, the geared link hinge is capable of coupling the first portion and the second portion. A damper can be provided that is integrated within the geared link hinge. In particular embodiments, a first gear is provided that is integrated into the first portion. A second gear is provided that is integrated into the second portion. The first gear engages with the second gear.

[122] In block 2404, a damper is provided. The damper is capable of controlling a rate at which the hinge mechanism automatically opens the device. In one aspect, the damper is passive. In another aspect, the damper is active. As an illustrative and non-limiting example, when the damper is implemented as an active damper, the damper may be

electronically controlled using a controller. As such, the damper is capable of providing a variable amount of damping to vary the rate at which the hinge mechanism opens the device.

- [123] In one or more embodiments, the hinge mechanism is capable of providing an angle of rotation of approximately 180 degrees formed of the first portion and the second portion. In one or more embodiments, the hinge mechanism is capable of providing an angle of rotation of approximately 360 degrees formed of the first portion and the second portion.
- [124] In block 2406, a latch is provided. The latch is capable of securing the first portion and the second portion in a closed position.
- [125] In an aspect, the latch is a magnetic latch. For example, a first set of magnetic poles can be provided on the first portion of the device. A second set of magnetic poles can be provided on the second portion of the device. The magnetic latch can be implemented or configured so that the first set of magnetic poles and the second set of magnetic poles are in a first alignment to attract when the magnetic latch is closed and in a second alignment to repel when the magnetic latch is opened.
- [126] In block 2408, a position stop mechanism optionally can be provided. The hinge mechanism is capable of providing a particular angle of rotation. The position stop mechanism is capable of providing a position stop at an angle that is less than the angle of rotation. In one aspect, the position stop mechanism is active. In one or more embodiments, the damper is capable of also implementing the position stop mechanism. For example, an active damper that can be electronically controlled can be controlled to provide a position stop and behave as a position stop mechanism under control of a controller. In another aspect, the position stop mechanism is passive.
- [127] FIGs. 25A and 25B illustrate an example of a cam/rocker position stop mechanism. In the example of FIG. 25A and 25B, a linkage 2502 is illustrated. In one or more embodiments, linkage 2502 may be used as the linkage in any of the examples described in connection with FIGs. 15-22B to provide position stops for device 100.
- [128] FIG. 25A is an overhead cutaway view of linkage 2502. In the example of FIG. 25A, a plurality of rockers (e.g., indentations) 2504 are built into an outer surface of linkage 2502. Rockers 2504 serve as position stops for device 100. A spring 2512 and a cam 2510 are also built into linkage 2502. Spring 2512 and cam 2510, for example, may be included in a channel or slot of portion 102 so that cam 2510 is in contact with linkage 2502 by virtue of force exerted by spring 2512. Spring 2512 is capable of providing downward force (in reference to the position of linkage 2502 illustrated in FIG. 25A) so that cam 2510 contacts linkage 2502 and is capable of settling into one of rockers 2504. As portion 102 rotates about axis of rotation 2508, cam 2510 is capable of settling into one or more of rockers 2504 in consequence of the force exerted by spring

2512.

- [129] In one or more embodiments, the cam rocker mechanism described in FIG. 25A and 25B is capable of stopping the automatic opening of device 100 as cam 2510 engages the first of rockers 2504. As device 100 is manually opened beyond the first cam, device 100 can continue to automatically open until a further rocker 2504 is encountered. Device 100 can be further manually opened beyond the second cam to continue automatically opening until a further cam is encountered.
- [130] FIG. 25B illustrates a side view of linkage 2502 showing the position of rockers 2504 in relation to axis of rotation 2508. Axis of rotation 2508 is going into the page in FIG. 25A. While three cams (e.g., position stops) are illustrated in FIGs. 25A and 25B, the embodiments described herein are not intended to be limited by the number of position stops provided. Fewer position stops or more position stops may be provided.
- [131] FIGs. 26A through 26D illustrate an example of a magnetic brake 2600. Magnetic brake 2600 can be incorporated into linkage 2502. In one or more embodiments, position stops are provided by the magnetic patterns created in the magnets included in magnetic brake 2600.
- [132] FIG. 26A is an overhead cutaway view of linkage 2502 and magnetic brake 2600. As pictured, magnetic brake 2600 includes magnets 2602 and 2604. In one or more embodiments, magnet 2602 is implemented as a south (north) magnet having one or more north (south) regions implemented therein. Magnet 2606 is implemented as a north (south) magnet having one or more south (north) regions implemented therein.
- [133] Magnet 2602 is fixedly attached to linkage 2502. Brake pad 2606 is fixedly attached to magnet 2602. Magnet 2604 is keyed to device 100 and, more particularly, to portion 102 via key 2610. Magnet 2604, for example, rotates in synchrony with portion 102 about axis of rotation 2508. Brake pad 2608 is fixedly attached to magnet 2604.
- [134] FIG. 26B illustrates a cross-sectional view of magnets 2602 and 2604 and of brake pads 2606 and 2608. In the example shown, magnet 2602 is a south magnet having a north region 2612 included therein. Magnet 2605 is north magnet having a plurality of south regions 2614, 2616, and 2618 implemented therein. As portion 102 of device 100 rotates about axis 2508, position stops occur, e.g., resistive force opposing the automatic opening of device 100, when north region 2612 of magnet 2602 aligns with one of south regions 2614, 2616, or 2618 of magnet 2604.
- [135] FIG. 26C illustrates a side view of magnet 2602 showing north region 2612. FIG. 26D illustrates a side view of magnet 2604 showing south regions 2614, 2616, and 2618.
- [136] The particular number of regions (e.g., regions 2612, 2614, 2616, and 2618) shown, the size of such regions, and the positioning of such regions can be varied to create any of a variety of different force profiles. The force profile determines the location of

position stops and how strong the position stop is to counteract the automatic opening of device 100.

[137] FIGs. 27A and 27B are side cutaway views illustrating another example of a spine hinge for device 100. The spine hinge of FIGs. 27A and 27B includes spines 2702 and 2704. Spines 2702 and 2704 may be implemented using any of the materials described herein for spines as previously described in connection with FIGs. 1-6. Referring to FIG. 27A, the spine hinge is shown in an open position with portion 102 and 104 forming an angle of 180 degrees or approximately 180 degrees. Spine 2702 is coupled to portion 104 using a pin 2706 or other suitable fastener. Spine 2704 is coupled to portion 104 using a pin 2708 or other suitable fastener. In one or more embodiments, spines 2702 and 2704 are rotatably coupled to portion 104.

[138] Portion 102 includes a spring 2710 and a linear damper 2712. Spring 2710 and linear damper 2712 are within a channel 2714 or cavity of portion 102. Channel 2714 can include two slits, where spine 2702 exits channel 2714 through one slit while spine 2704 exits channel 2714 through another slit. Spring 2710 is capable of providing the force for automatically opening the spine hinge and device 100. Linear damper 2712 is capable of providing a dampening force that opposes the force exerted by spring 2710.

[139] Referring to FIG. 27B, device 100 is opened at an angle of approximately 90 degrees (as measured moving clockwise from portion 102 portion 104). As pictured, spine 2702 is extracted, at least partially, from channel 2714 thereby compressing spring 2710. Were device 100 rotated in the opposite direction to open at an angle of approximately 90 degrees (as measured moving counter-clockwise from portion 102 to 104), then spine 2704 is extracted from channel 2714 thereby compressing spring 2710.

[140] As illustrated, spine 2702 includes a head portion 2716 and spine 2704 includes a head portion 2718. Each of head portions 2716 and 2718 is capable of engaging spring 2710 and linear damper 2712 to exert compressive force when device 100 is moved from the position illustrated in FIG. 27A. In the example of FIG. 27B head portion 2716 is capable of grasping or catching spring 2710 and linear damper 2712 while device 100 is rotated from the position illustrated in FIG. 27A and compressing both. Were device 100 rotated in the opposite direction to open at an angle of approximately 90 degrees (as measured moving counter-clockwise from portion 102 to 104), then head portion 2718 of spine 2704 is capable of grasping or catching spring 2710 and linear damper 2712 and compressing both.

[141] The spine hinge mechanism illustrated in FIGs. 27A and 27B is capable of providing 360 degrees or approximately 360 degrees of rotation. A suitable latch as described herein can be provided to maintain device in a closed position or in an open position, e.g., when opened 365 degrees from the closed position. In one or more embodiments,

the spine hinge mechanism illustrated in FIGs. 27A and 27B can include more than one spring 2710 and linear damper 2712 within channel 2714.

[142] The terminology used herein is for the purpose of describing particular embodiments only and is not intended to be limiting. Notwithstanding, several definitions that apply throughout this document now will be presented.

[143] As defined herein, the singular forms "a," "an," and "the" are intended to include the plural forms as well, unless the context clearly indicates otherwise. As defined herein, the terms "at least one," "one or more," and "and/or," are open-ended expressions that are both conjunctive and disjunctive in operation unless explicitly stated otherwise. For example, each of the expressions "at least one of A, B, and C," "at least one of A, B, or C," "one or more of A, B, and C," "one or more of A, B, or C," and "A, B, and/or C" means A alone, B alone, C alone, A and B together, A and C together, B and C together, or A, B and C together. As defined herein, the term "automatically" means without user intervention.

[144] By the term "approximately" it is meant that the recited characteristic, parameter, or value need not be achieved exactly, but that deviations or variations, including for example, tolerances, measurement error, measurement accuracy limitations and other factors known to those of skill in the art, may occur in amounts that do not preclude the effect the characteristic was intended to provide.

[145] As defined herein, the terms "one embodiment," "an embodiment," "one or more embodiments," or similar language mean that a particular feature, structure, or characteristic described in connection with the embodiment is included in at least one embodiment described within this disclosure. Thus, appearances of the phrases "in one embodiment," "in an embodiment," "in one or more embodiments," and similar language throughout this disclosure may, but do not necessarily, all refer to the same embodiment. The terms "embodiment" and "arrangement" are used interchangeably within this disclosure.

[146] As defined herein, the term "processor" means at least one hardware circuit configured to carry out instructions contained in program code. The hardware circuit may be an integrated circuit. Examples of a processor include, but are not limited to, a central processing unit (CPU), an array processor, a vector processor, a digital signal processor (DSP), a field-programmable gate array (FPGA), a programmable logic array (PLA), an application specific integrated circuit (ASIC), programmable logic circuitry, a graphics processing unit (GPU), and a controller.

[147] The terms first, second, etc. may be used herein to describe various elements. These elements should not be limited by these terms, as these terms are only used to distinguish one element from another unless stated otherwise or the context clearly indicates otherwise.

- [148] In some alternative implementations, the operations noted in the blocks may occur out of the order noted in the figures. For example, two blocks shown in succession may be executed substantially concurrently, or the blocks may sometimes be executed in the reverse order, depending upon the functionality involved. In other examples, blocks may be performed generally in increasing numeric order while in still other examples, one or more blocks may be performed in varying order.
- [149] The corresponding structures, materials, acts, and equivalents of all means or step plus function elements that may be found in the claims below are intended to include any structure, material, or act for performing the function in combination with other claimed elements as specifically claimed.
- [150] The description of the embodiments provided herein is for purposes of illustration and is not intended to be exhaustive or limited to the form and examples disclosed. The terminology used herein was chosen to explain the principles of the inventive arrangements, the practical application or technical improvement over technologies found in the marketplace, and/or to enable others of ordinary skill in the art to understand the embodiments disclosed herein. Modifications and variations may be apparent to those of ordinary skill in the art without departing from the scope and spirit of the described inventive arrangements. Accordingly, reference should be made to the following claims, rather than to the foregoing disclosure, as indicating the scope of such features and implementations.

## Claims

- [Claim 1] A device, comprising:  
a hinge mechanism rotatably coupling a first portion of the device to a second portion of the device, wherein the hinge mechanism is configured to automatically open the device;  
a damper configured to control a rate at which the hinge mechanism automatically opens the device; and  
wherein the hinge mechanism includes a spine hinge, a rolling contact hinge, a film hinge, or a geared link hinge.
- [Claim 2] The device of claim 1, wherein the hinge mechanism is configured to provide an angle of rotation of approximately 180 degrees formed of the first portion and the second portion.
- [Claim 3] The device of claim 1, wherein the hinge mechanism is configured to provide an angle of rotation of approximately 360 degrees formed of the first portion and the second portion.
- [Claim 4] The device of claim 1, further comprising:  
a latch configured to secure the first portion and the second portion in a closed position.
- [Claim 5] The device of claim 4, wherein the latch is a magnetic latch wherein the magnetic latch comprises:  
a first set of magnetic poles on the first portion; and  
a second set of magnetic poles on the second portion;  
wherein the first set of magnetic poles and the second set of magnetic poles are in a first alignment to attract when the magnetic latch is closed and in a second alignment to repel when the magnetic latch is opened.
- [Claim 6] The device of claim 1, wherein the hinge mechanism is configured to provide an angle of rotation, the hinge mechanism further comprising:  
a position stop mechanism configured to provide a position stop at an angle that is less than the angle of rotation.
- [Claim 7] The device of claim 1, wherein the spine hinge comprises:  
a first retractable spine; and  
a second retractable spine opposing the first retractable spine.
- [Claim 8] The device of claim 1, wherein the rolling contact hinge is a magnetic rolling contact hinge, wherein the magnetic rolling contact hinge comprises:  
a first array of magnets arranged in a first formation within a rounded

- end of the first portion; and  
a second array of magnets arranged in a second formation within a rounded end of the second portion;  
wherein the second formation opposes the first formation and corresponding points along the first array of magnets and the second array of magnets attract to facilitate rolling contact between the rounded end of the first portion and the rounded end of the second portion.
- [Claim 9] The device of claim 8, wherein the first formation is at least a partial helix having a first handedness and the second formation is at least a partial helix having an opposing handedness.
- [Claim 10] The device of claim 8, wherein the magnetic rolling contact hinge comprises:  
a first polymagnet in a first formation within a rounded end of the first portion; and  
a second polymagnet in a second formation within a rounded end of the second portion;  
wherein the second formation opposes the first formation and corresponding points along the first polymagnet and the second polymagnet attract to facilitate rolling contact between the rounded end of the first portion and the rounded end of the second portion.
- [Claim 11] The device of claim 1, wherein the rolling contact hinge comprises:  
a first strap coupled to a top surface of the first portion and a bottom surface of the second portion; and  
a second strap coupled to a bottom surface of the first portion and a top surface of the second portion;  
wherein the first strap and the second strap facilitate rolling contact between a rounded end of the first portion and a rounded end of the second portion.
- [Claim 12] The device of claim 1, wherein the geared link hinge is coupled to the first portion and the second portion and the damper is integrated within the geared link hinge.
- [Claim 13] A method, comprising:  
providing a hinge mechanism rotatably coupling a first portion of a device to a second portion of the device, wherein the hinge mechanism is configured to automatically open the device;  
providing a damper configured to control a rate at which the hinge mechanism automatically opens the device; and  
wherein the hinge mechanism includes a spine hinge, a rolling contact

hinge, a film hinge, or a geared link hinge.

[Claim 14]

The method of claim 13, further comprising, for the magnetic rolling contact hinge:

providing a first array of magnets arranged in a first formation within a rounded end of the first portion; and

providing a second array of magnets arranged in a second within a rounded end of the second portion;

wherein the second formation opposes the first formation and corresponding points along the first array of magnets and the second array of magnets attract to facilitate rolling contact between the rounded end of the first portion and the rounded end of the second portion.

[Claim 15]

The method of claim 13, further comprising, for the rolling contact hinge:

providing a first strap coupled to a top surface of the first portion and a bottom surface of the second portion; and

providing a second strap coupled to a bottom surface of the first portion and a top surface of the second portion;

wherein the first strap and the second strap facilitate rolling contact between a rounded end of the first portion and a rounded end of the second portion.

[Fig. 1]  
100

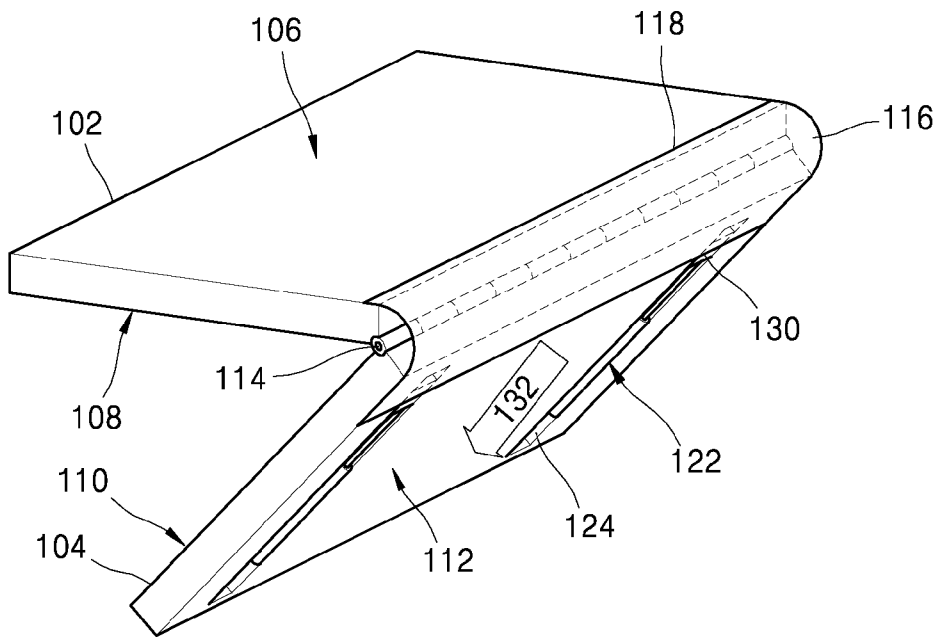

[Fig. 2]  
100

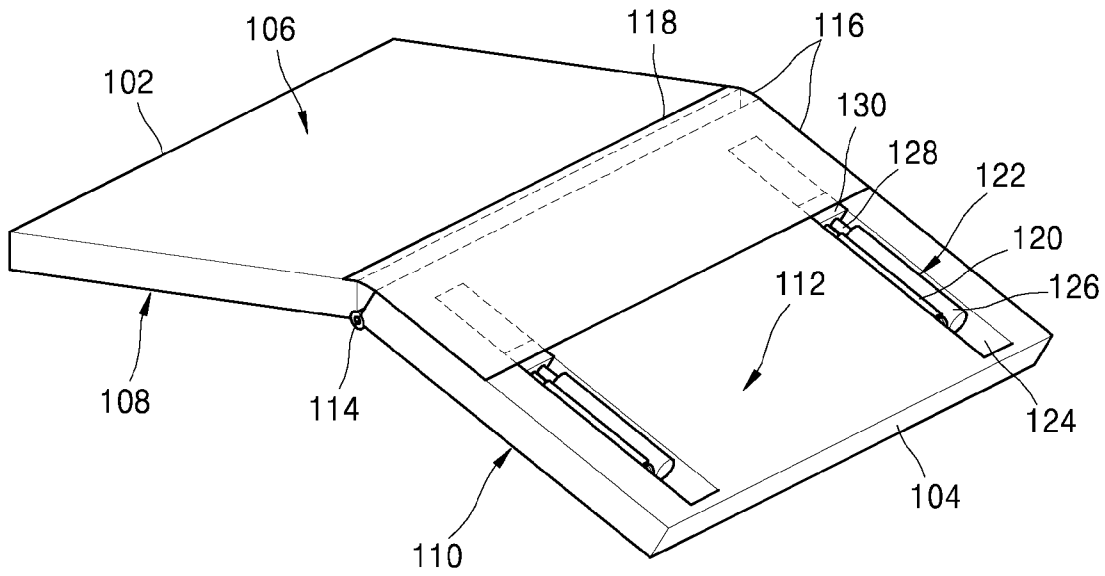

[Fig. 3]

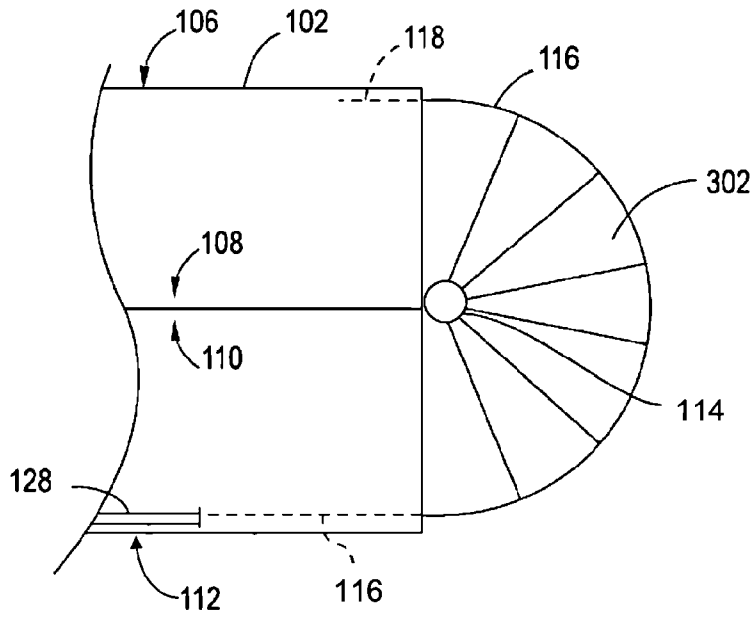

[Fig. 4]

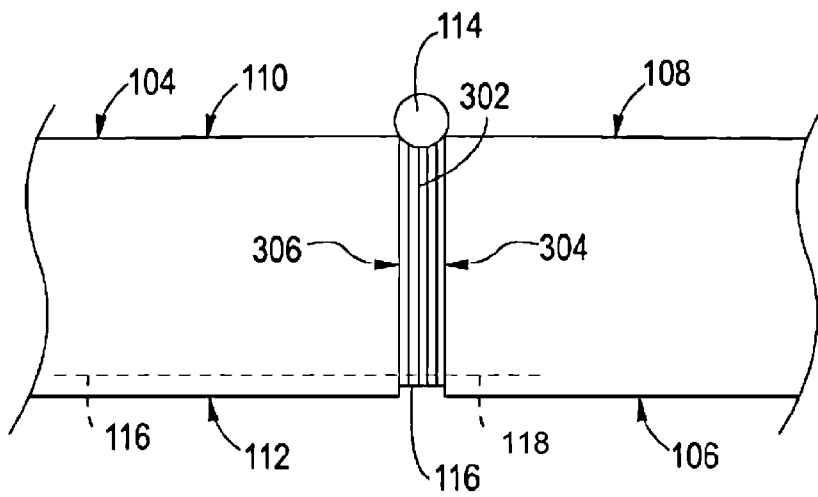

[Fig. 5]

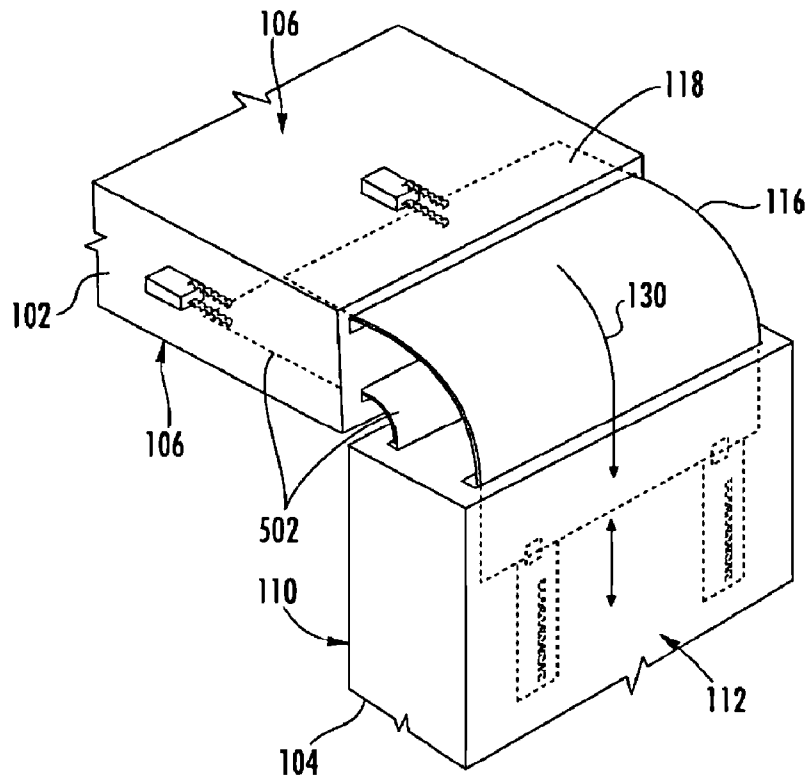

[Fig. 6]

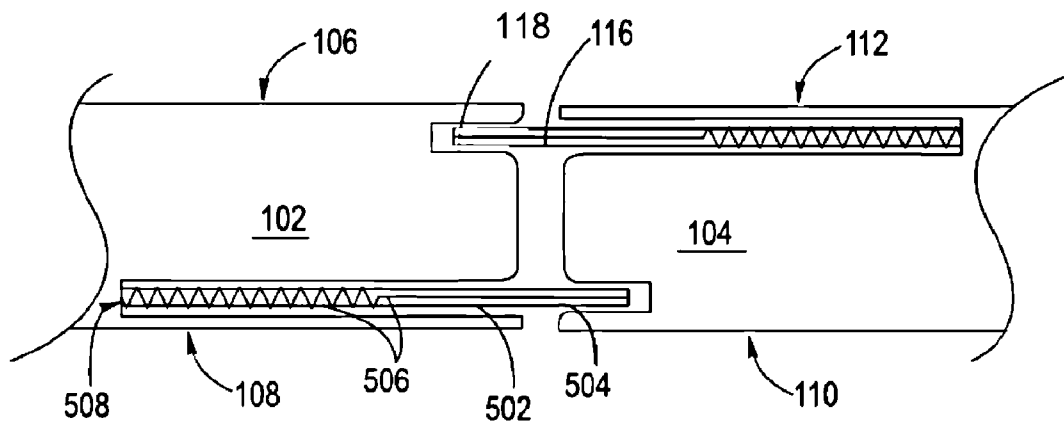

[Fig. 7]

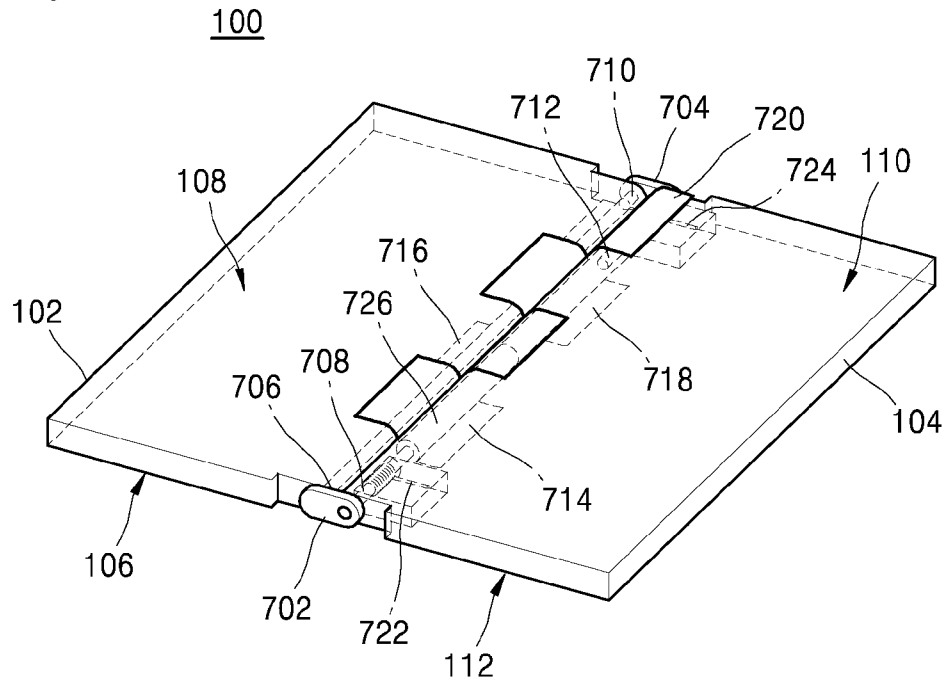

[Fig. 8A]

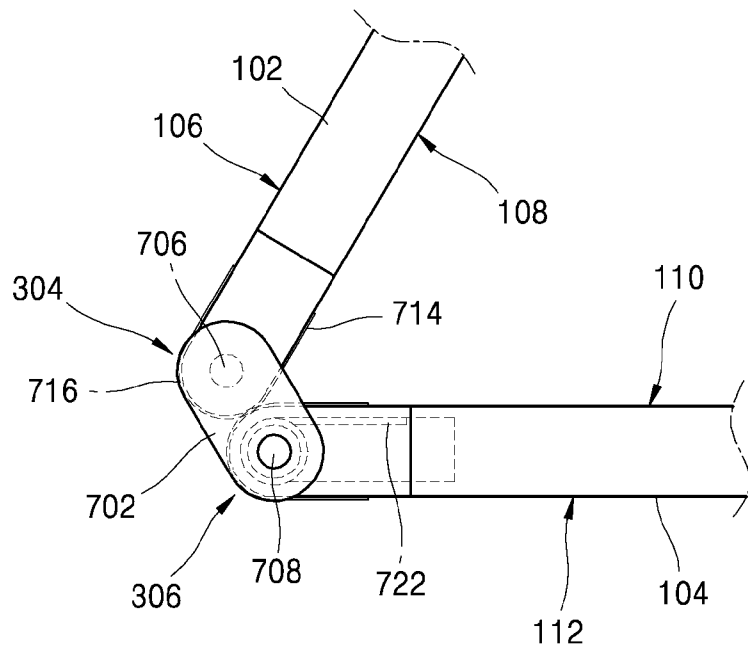

[Fig. 8B]

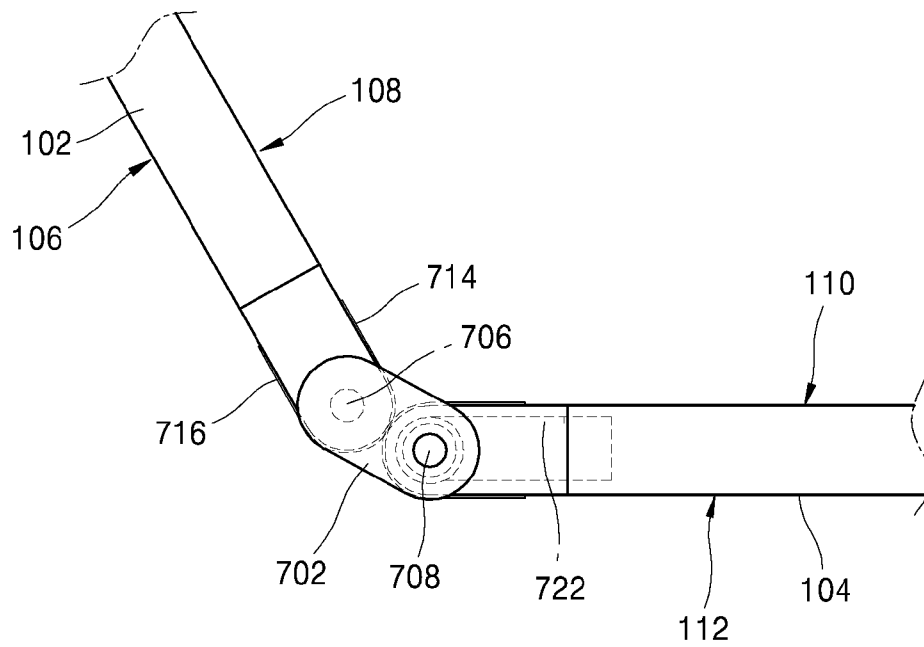

[Fig. 8C]

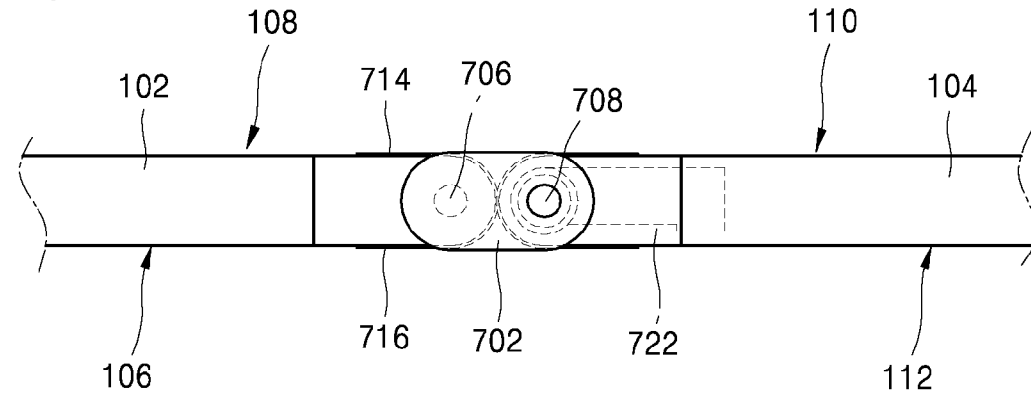

[Fig. 8D]

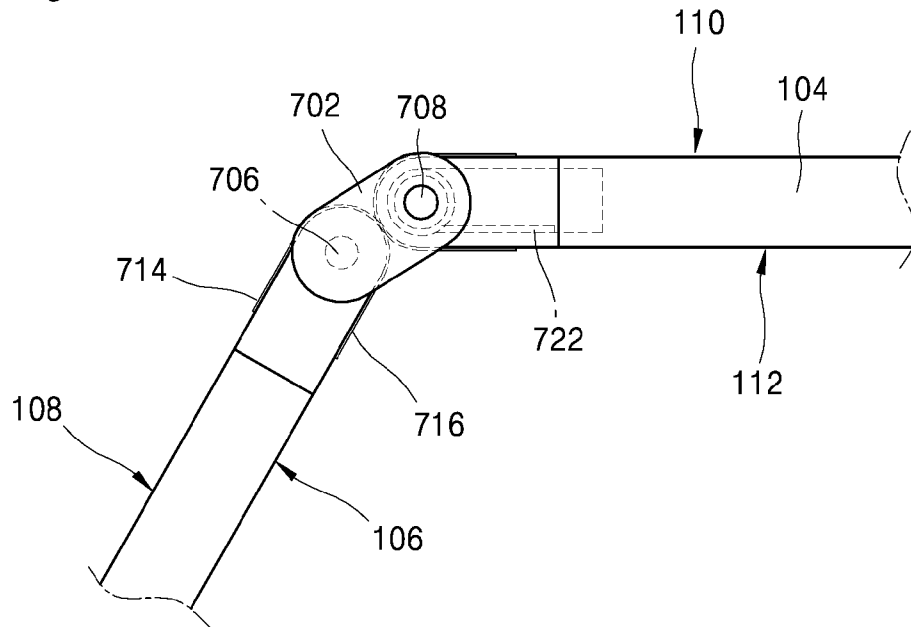

[Fig. 8E]

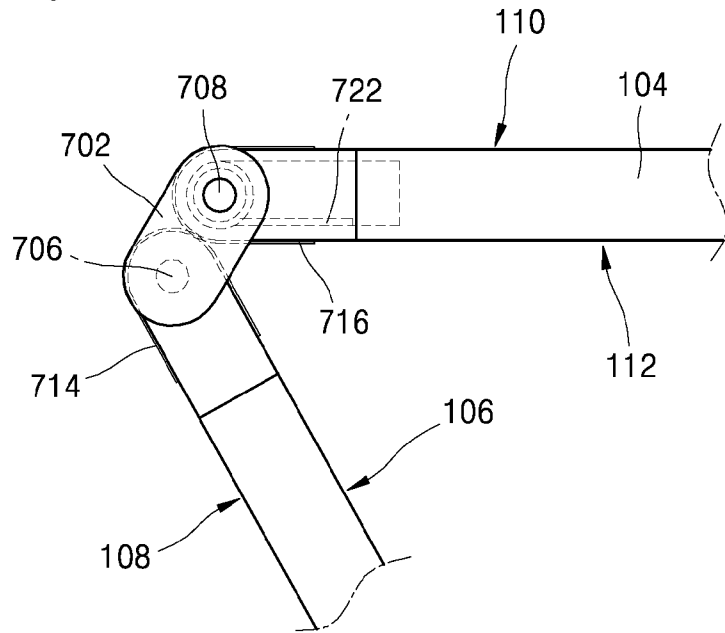

[Fig. 9]

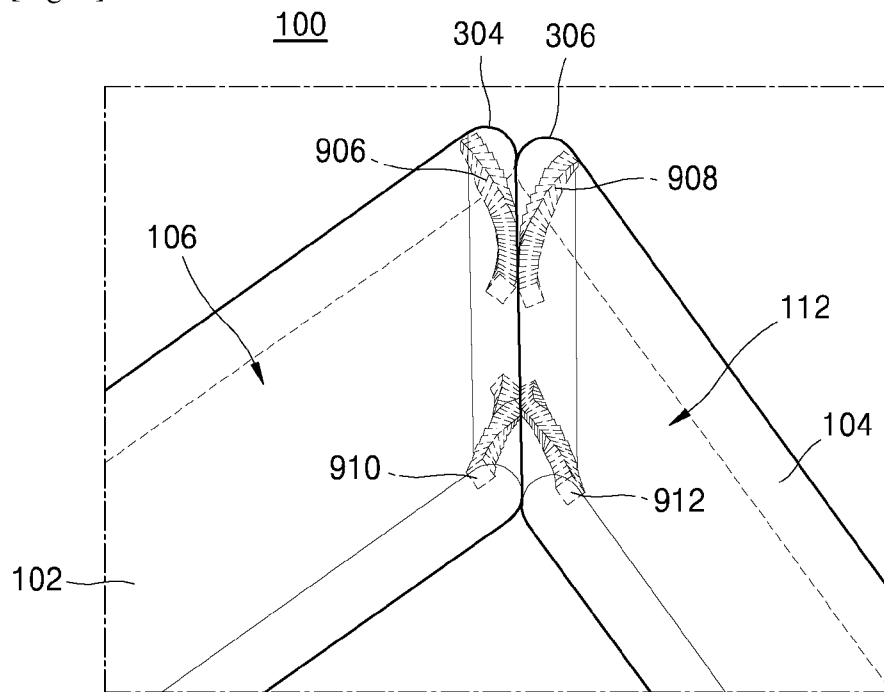

[Fig. 10]

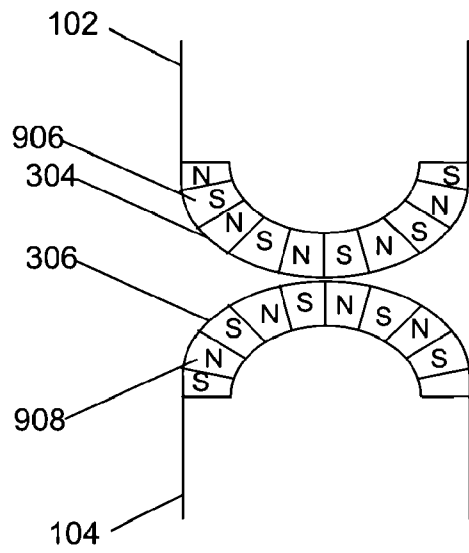

[Fig. 11]

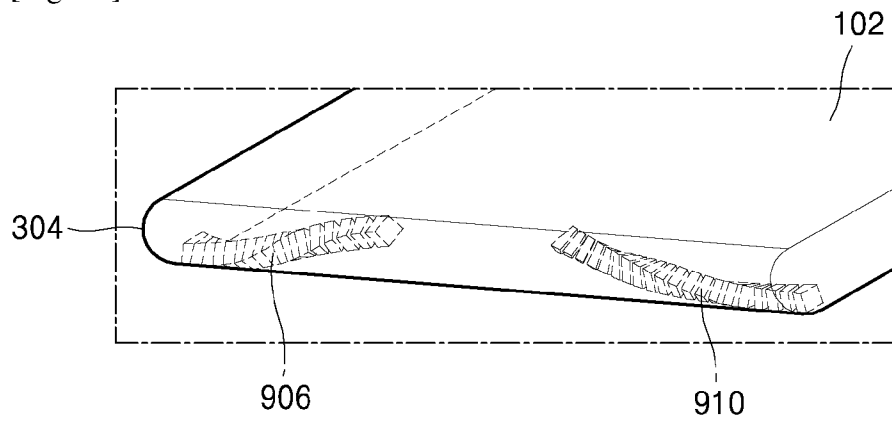

[Fig. 12]

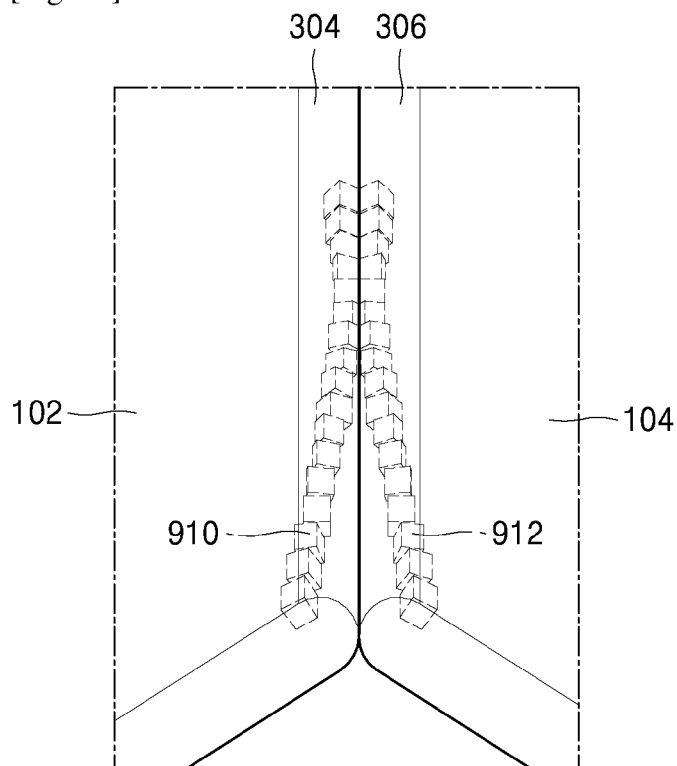

[Fig. 13]

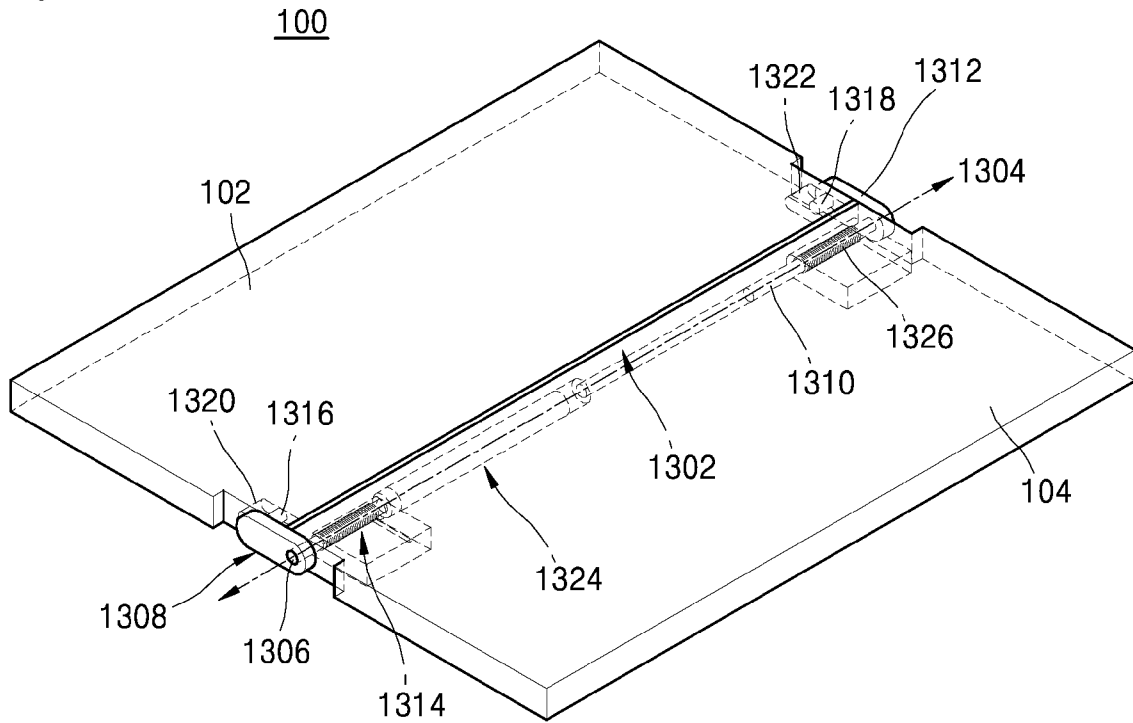

[Fig. 14A]

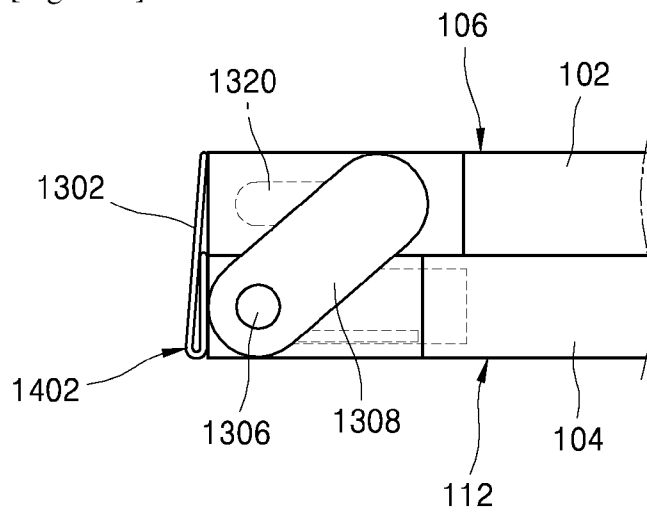

[Fig. 14B]

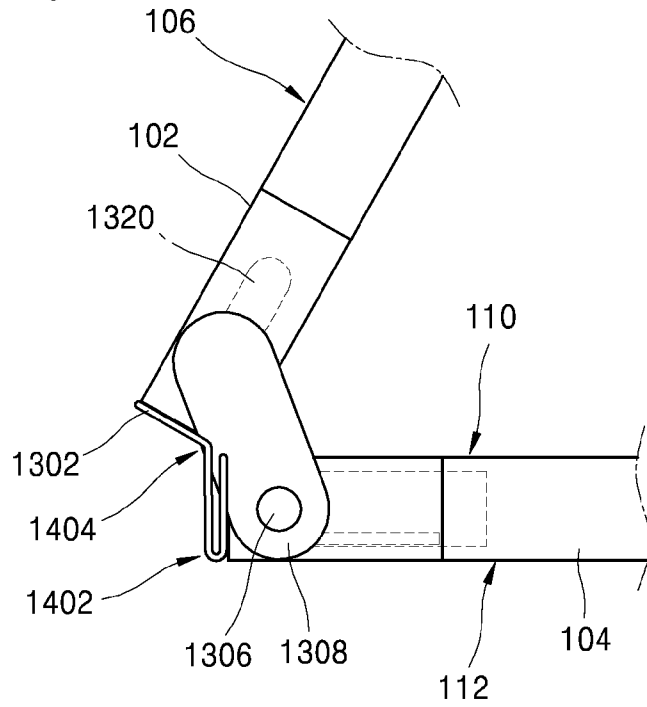

[Fig. 14C]

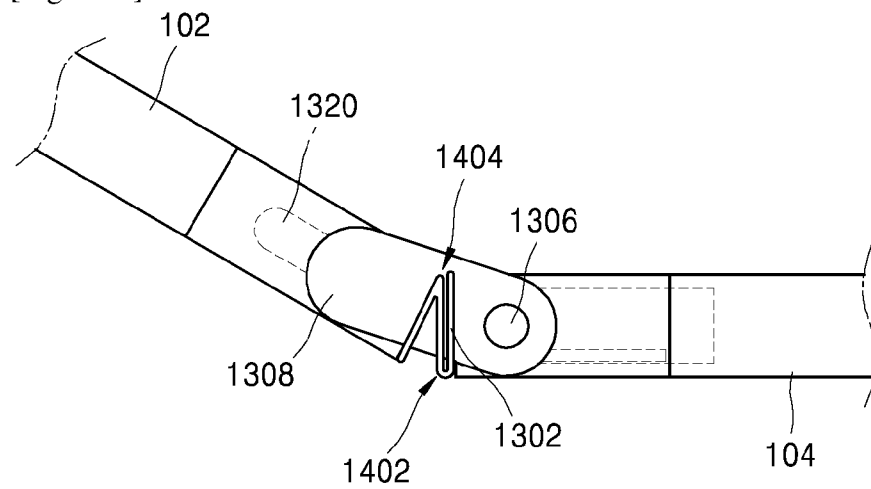

[Fig. 14D]

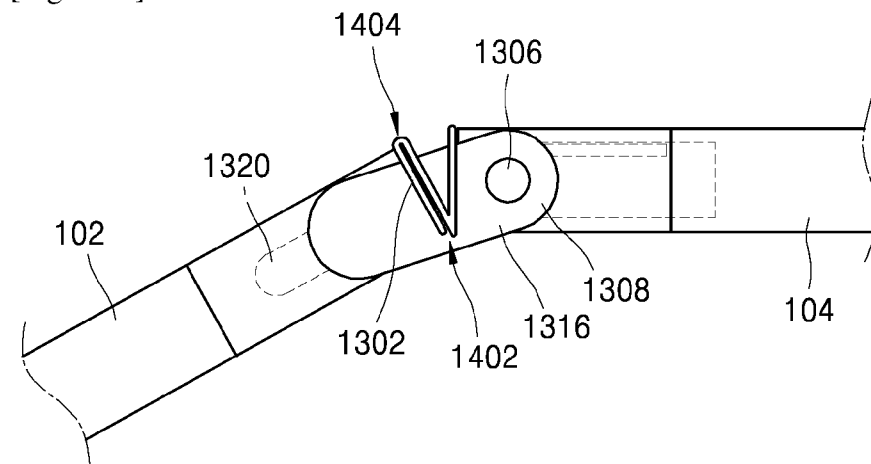

[Fig. 14E]

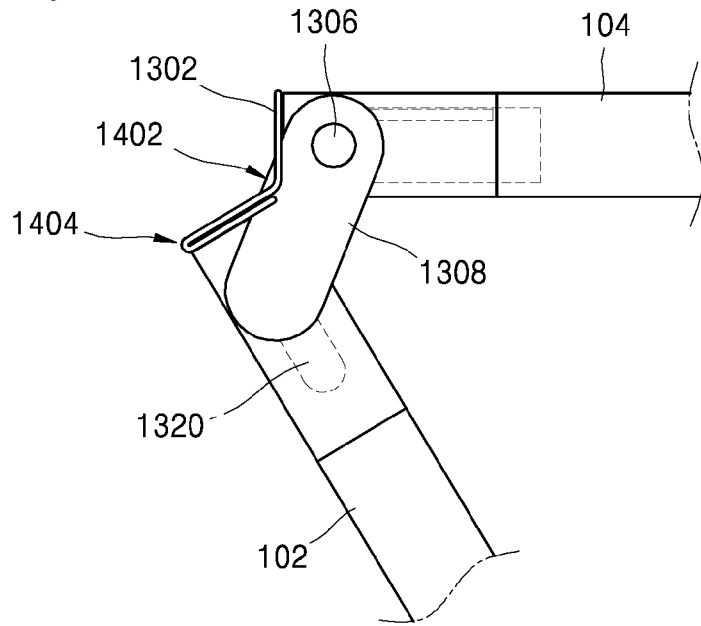

[Fig. 14F]

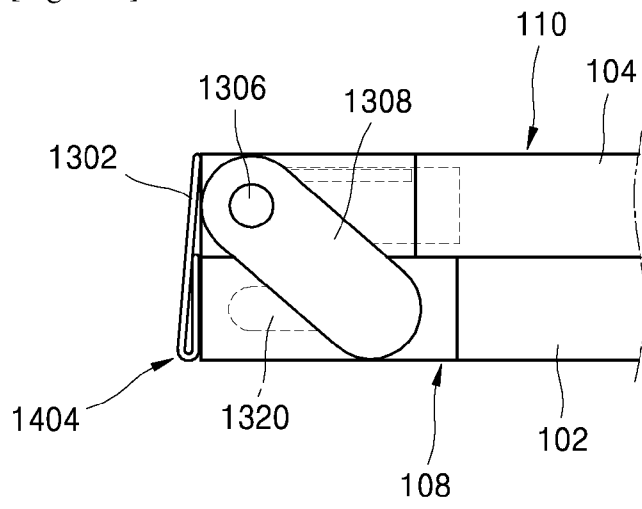

[Fig. 15]

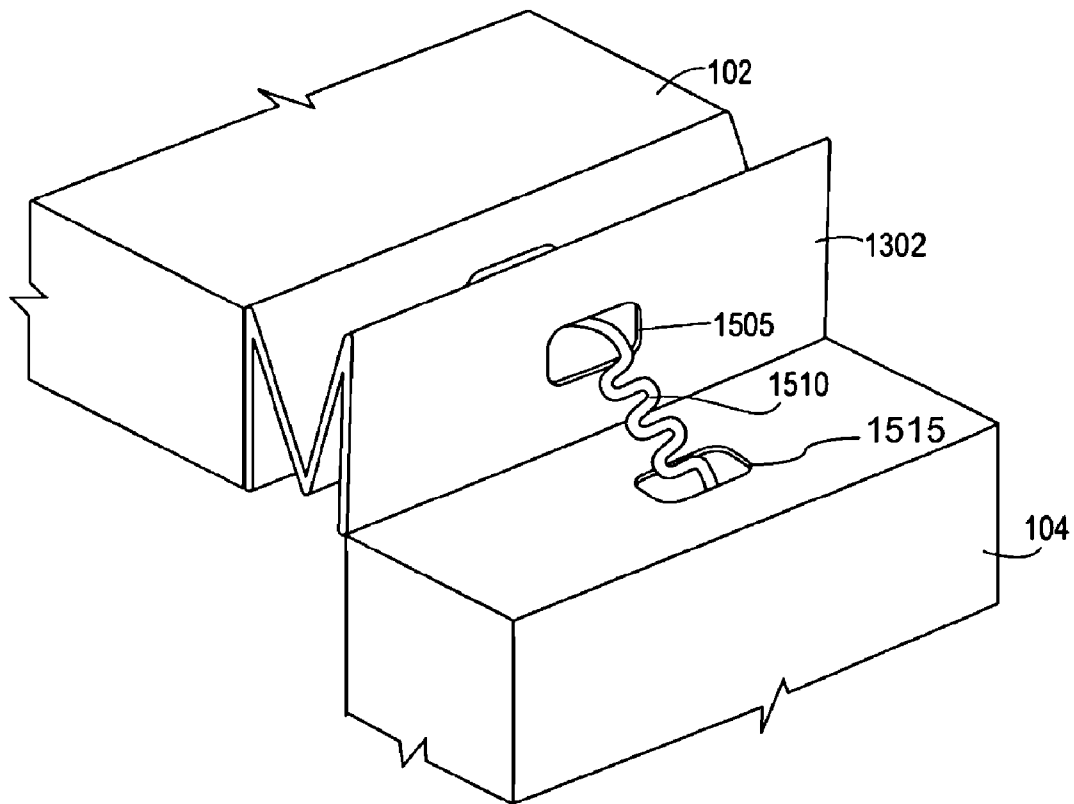

[Fig. 16]

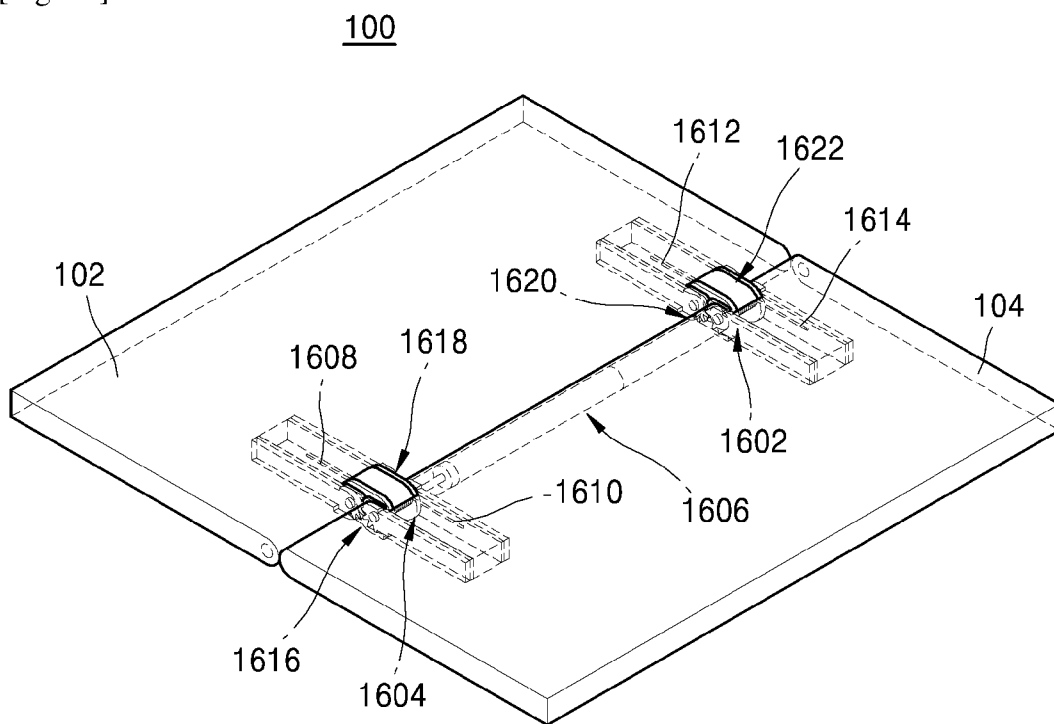

[Fig. 17A]

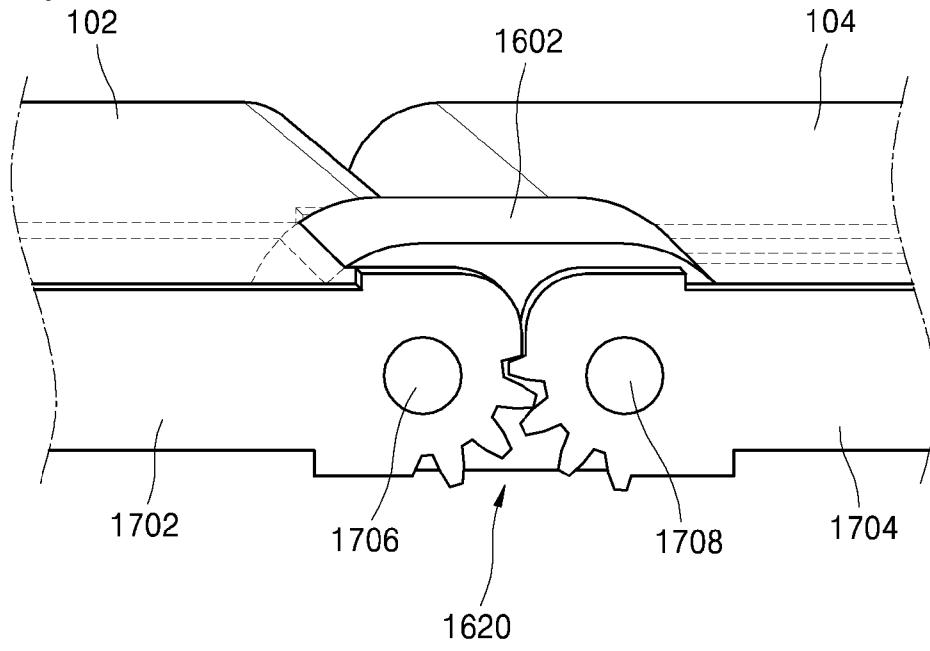

[Fig. 17B]

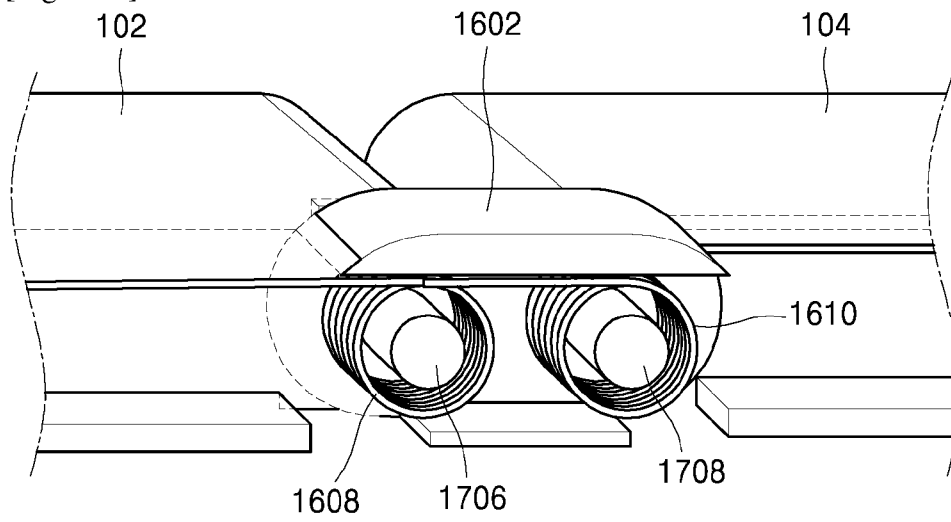

[Fig. 18]

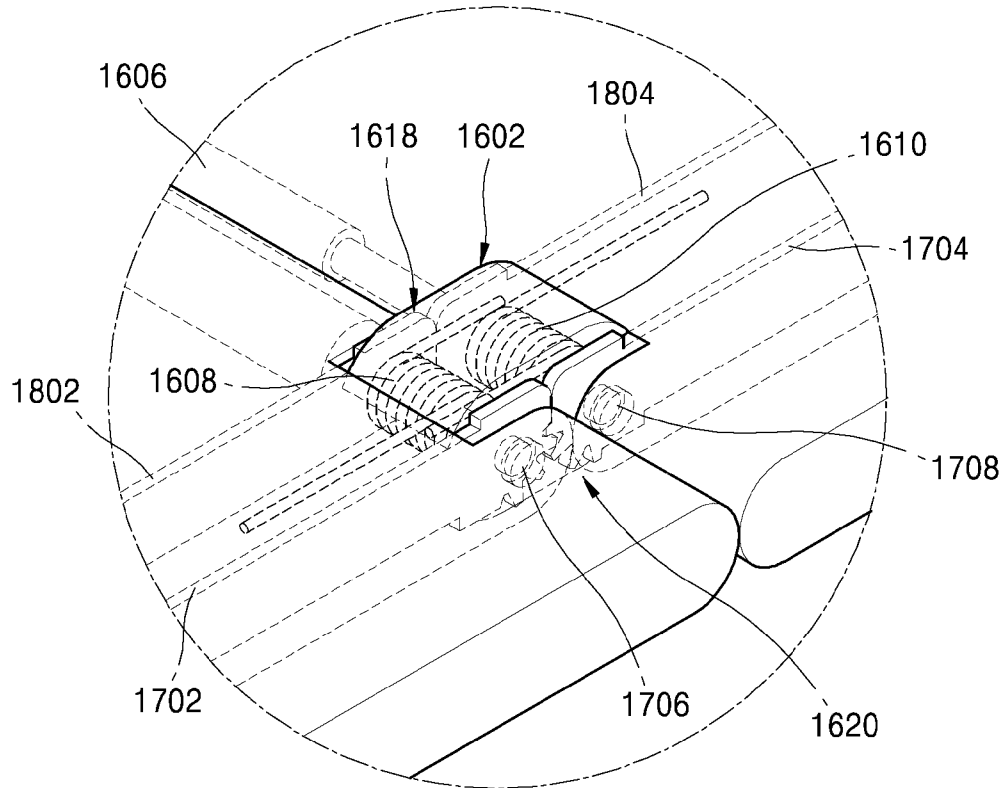

[Fig. 19]

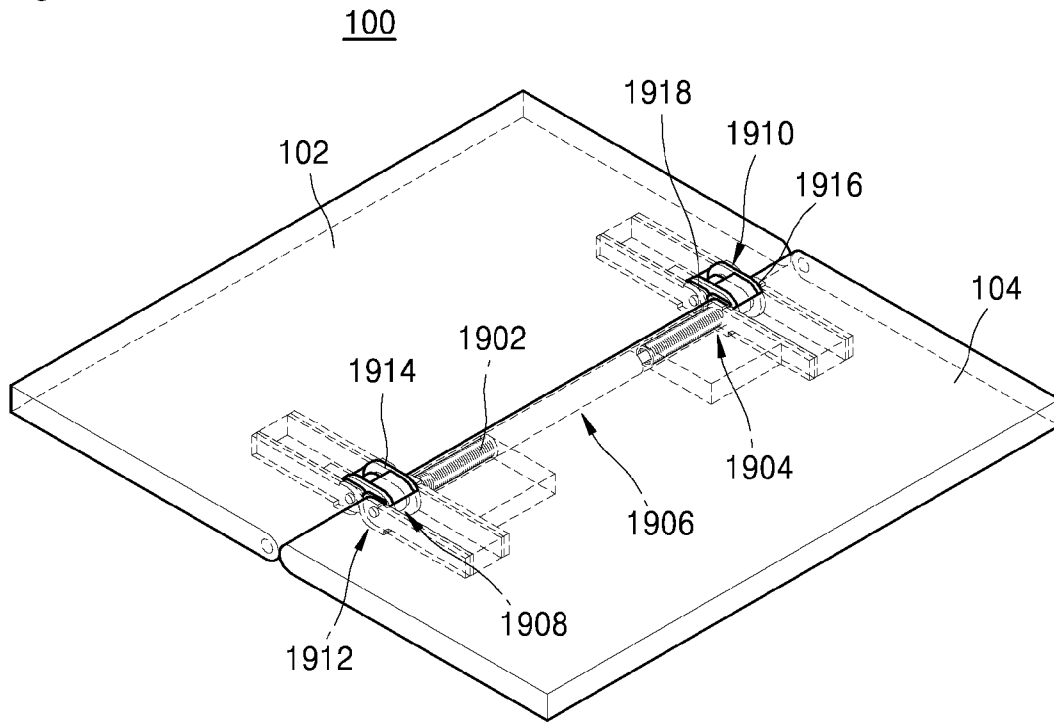

[Fig. 20A]

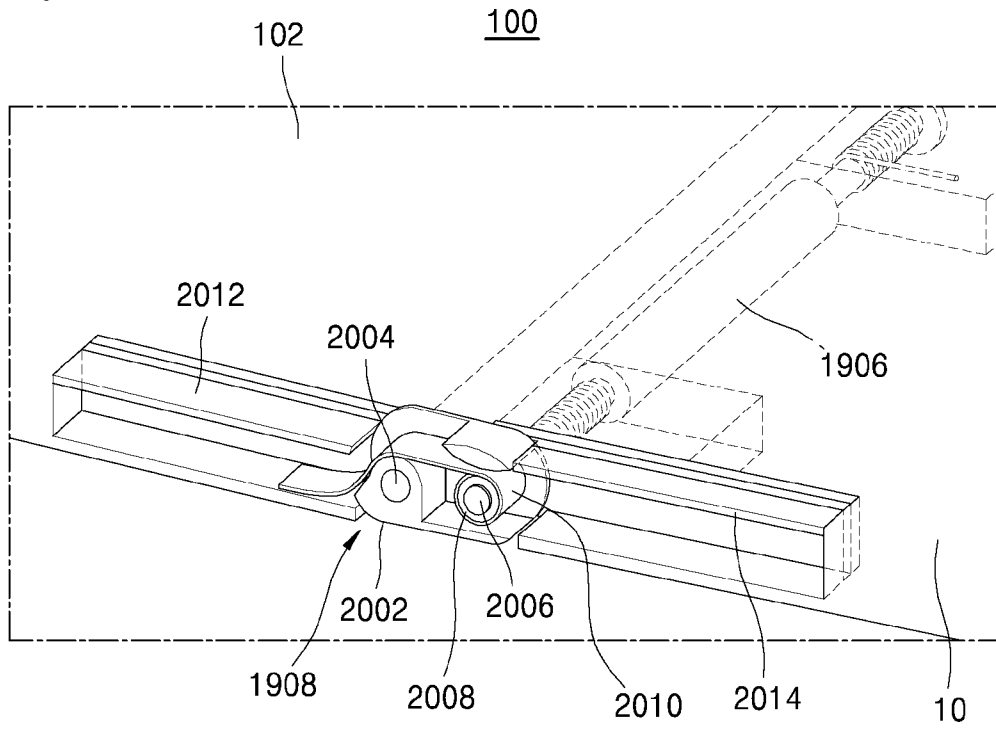

[Fig. 20B]

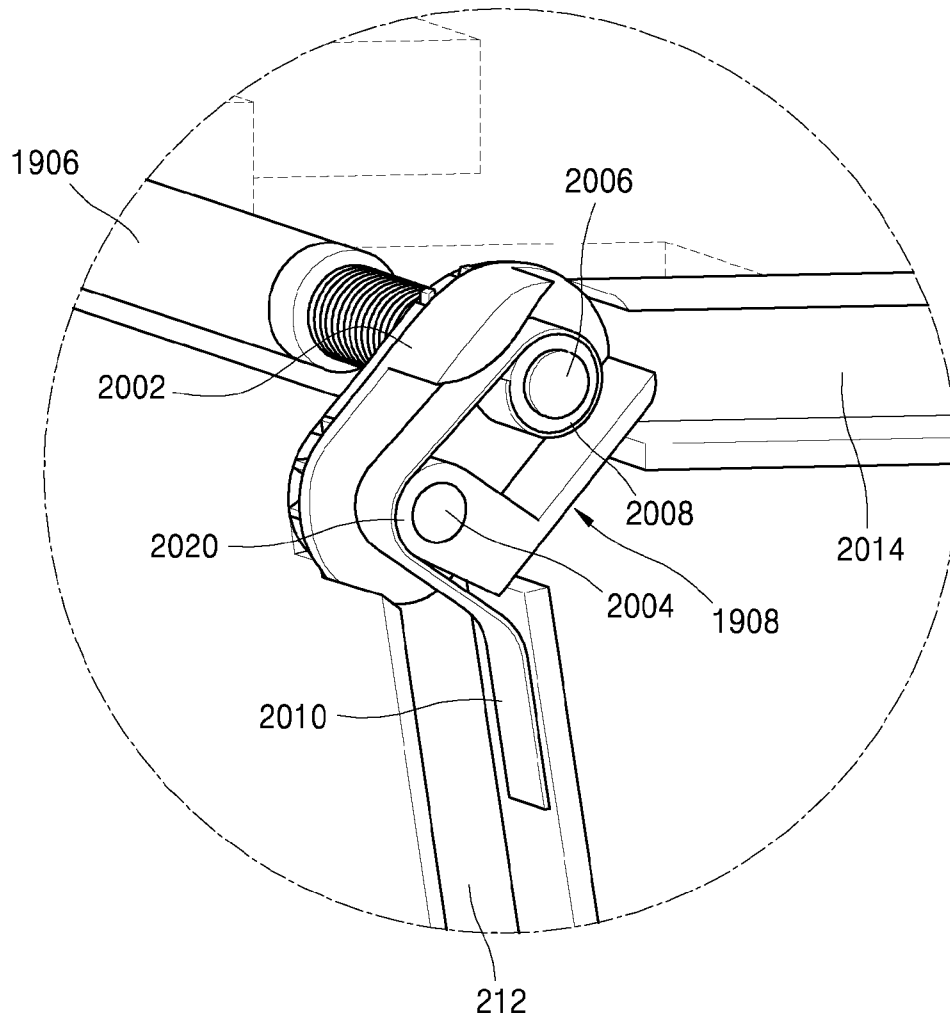

[Fig. 20C]

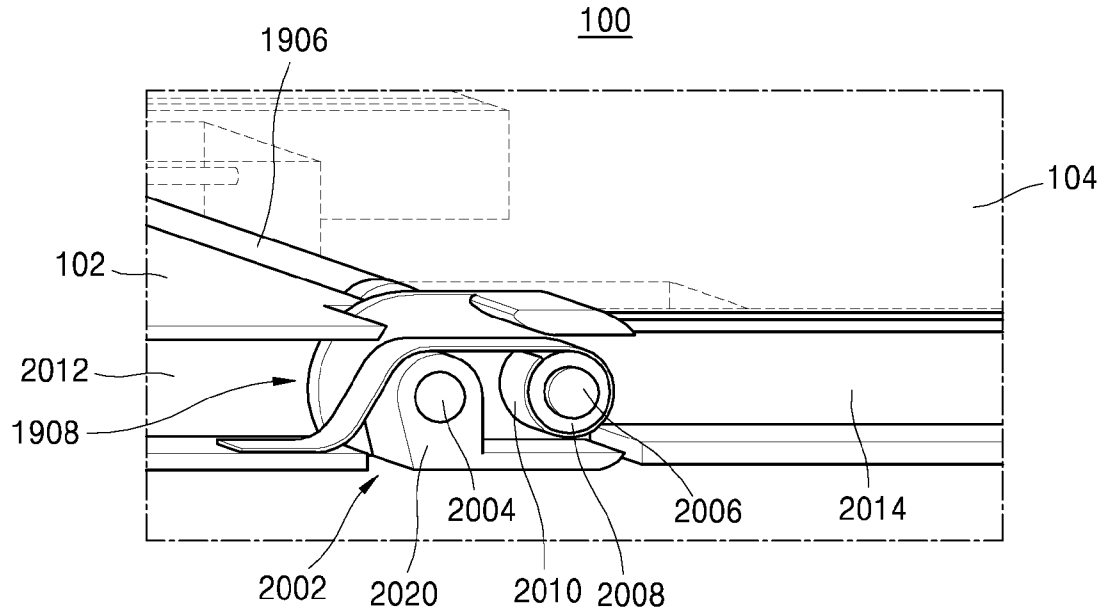

[Fig. 20D]

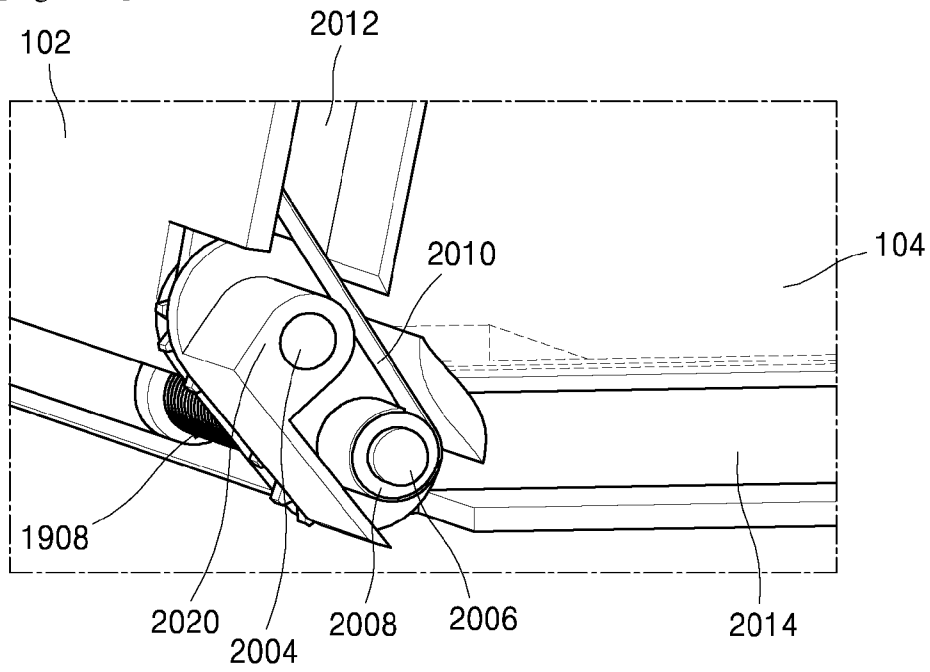

[Fig. 21]

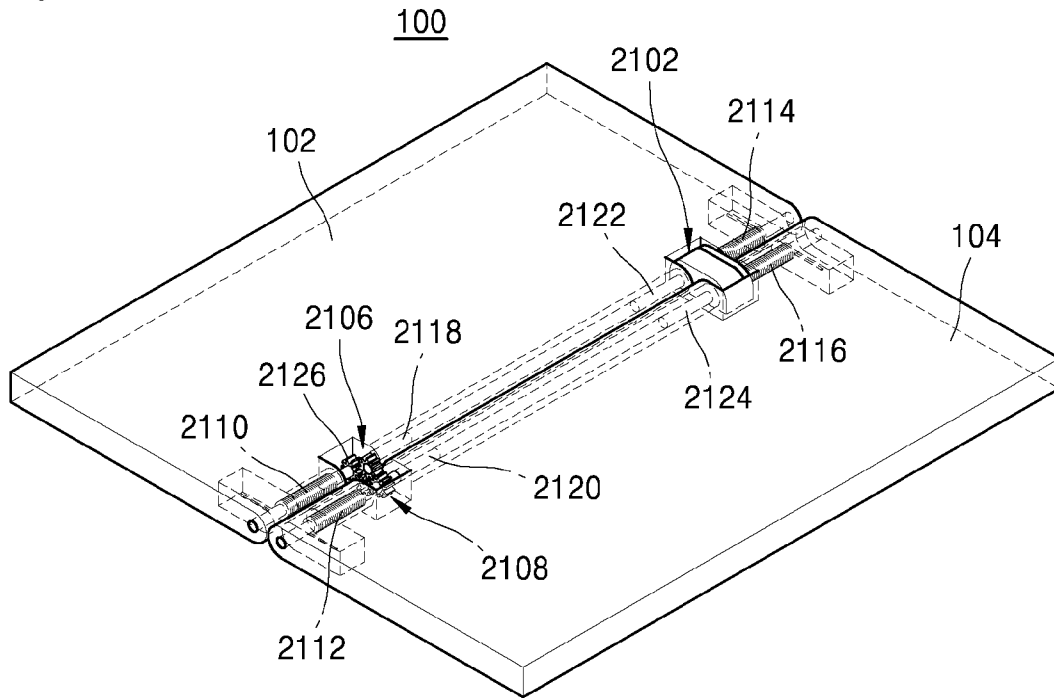

[Fig. 22A]

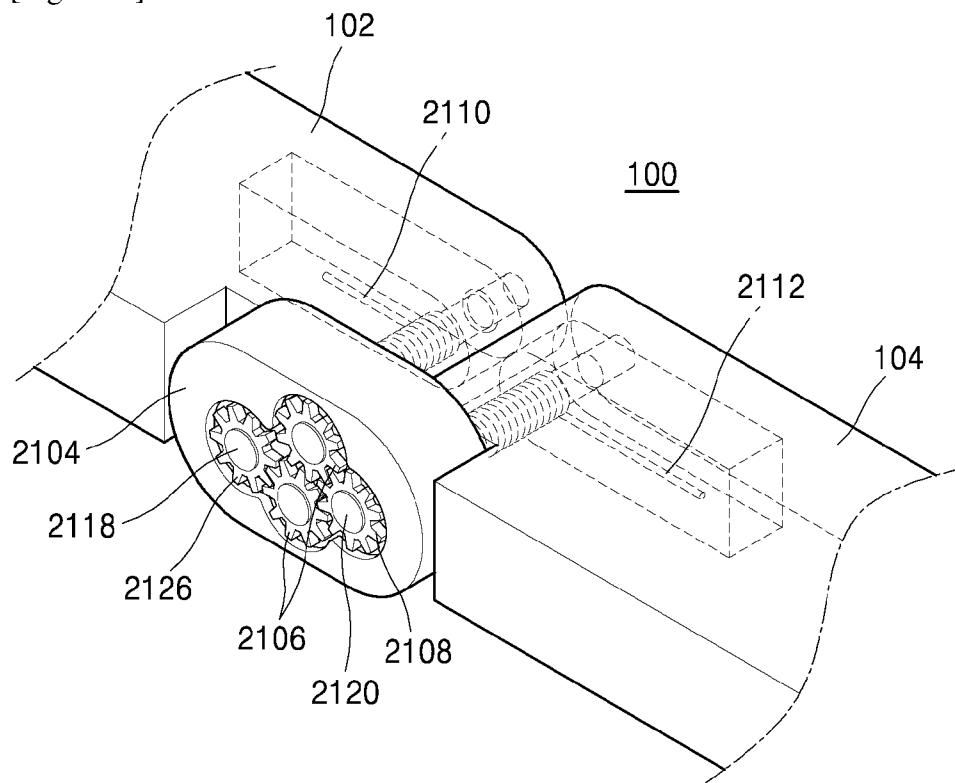

[Fig. 22B]

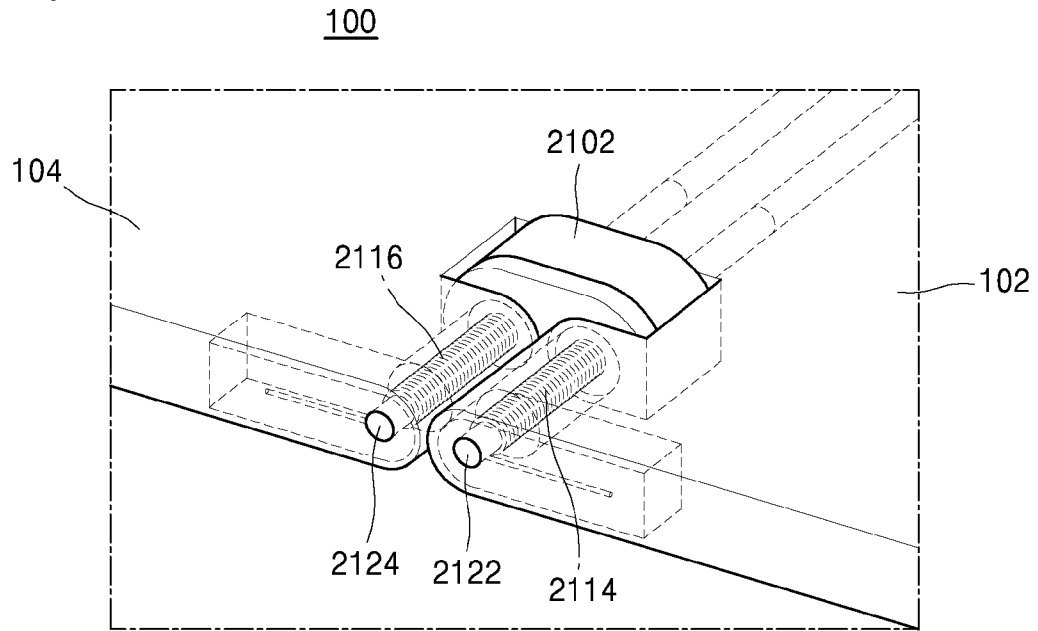

[Fig. 23]

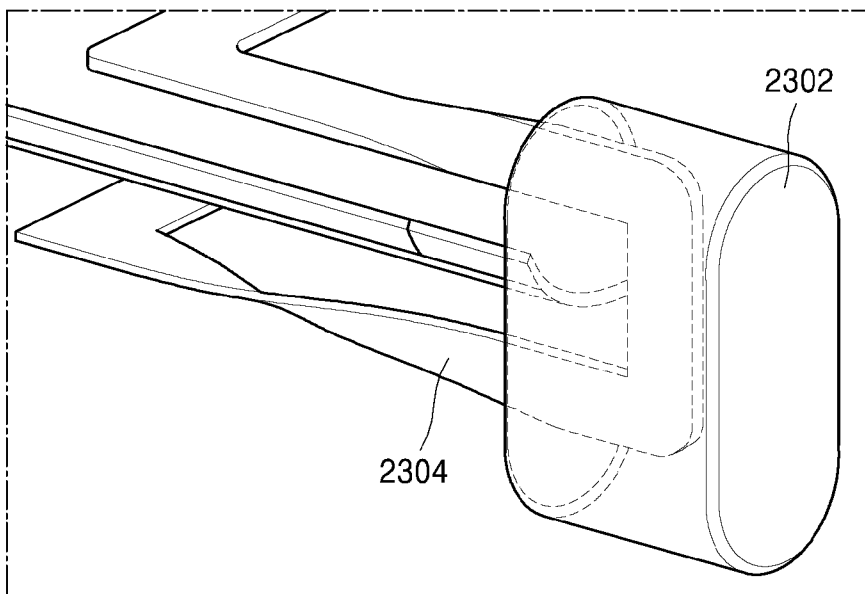

[Fig. 24]

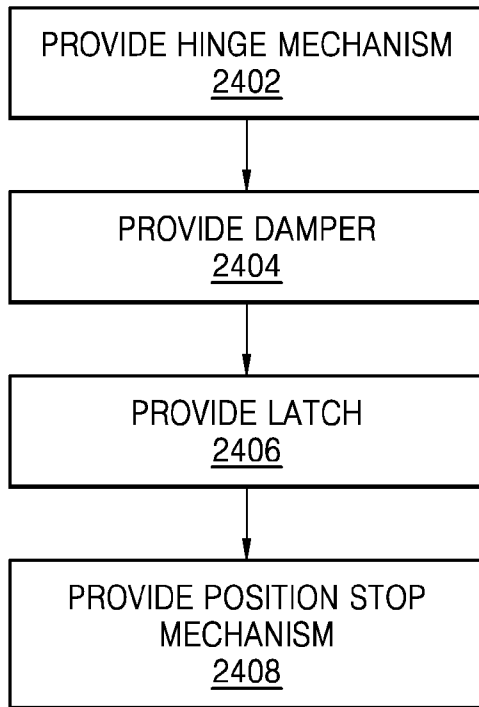

[Fig. 25A]

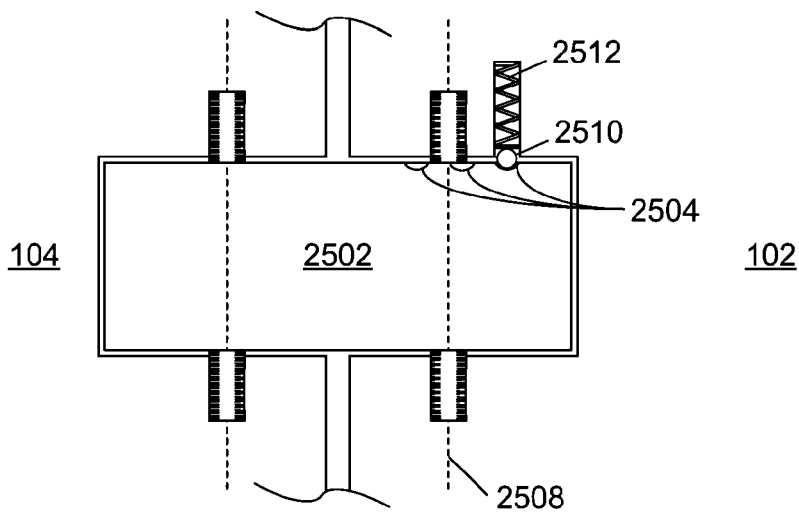

[Fig. 25B]

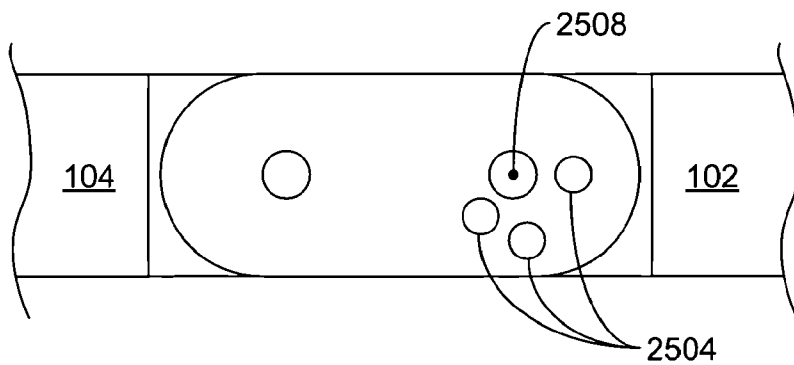

[Fig. 26A]

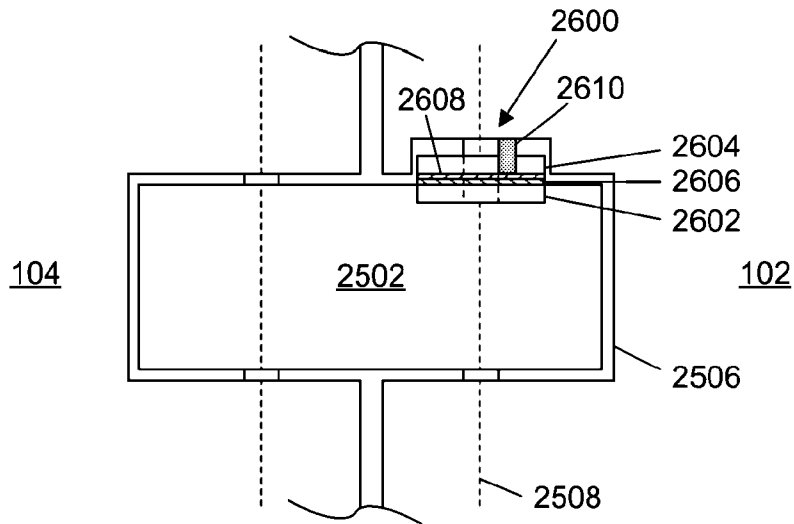

[Fig. 26B]

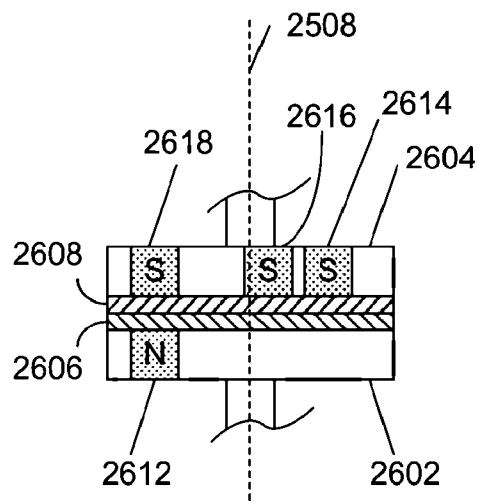

[Fig. 26C]

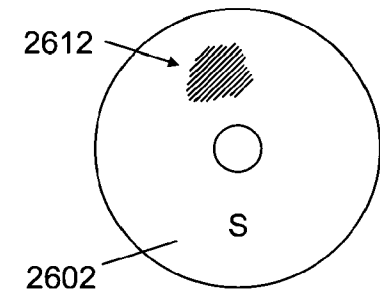

[Fig. 26D]

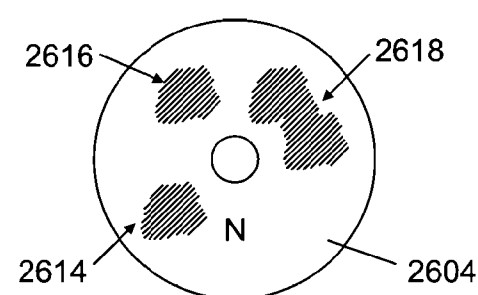

[Fig. 27A]

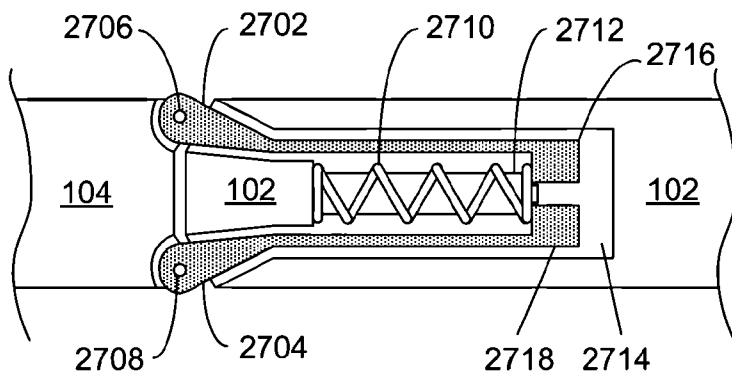

[Fig. 27B]

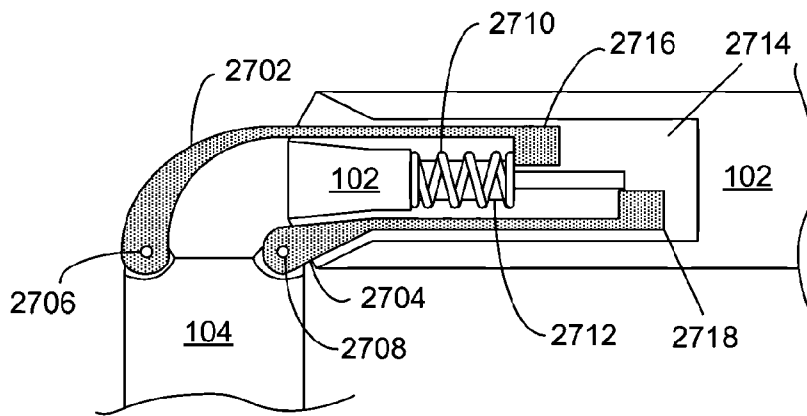

**A. CLASSIFICATION OF SUBJECT MATTER****H04M 1/02(2006.01)i**

According to International Patent Classification (IPC) or to both national classification and IPC

**B. FIELDS SEARCHED**Minimum documentation searched (classification system followed by classification symbols)  
H04M 1/02; H04W 88/02; G09F 9/00; H04M 1/00; G06F 1/16Documentation searched other than minimum documentation to the extent that such documents are included in the fields searched  
Korean utility models and applications for utility models  
Japanese utility models and applications for utility modelsElectronic data base consulted during the international search (name of data base and, where practicable, search terms used)  
eKOMPASS(KIPO internal) & Keywords: hinge, damper, magnet, spine, rotate**C. DOCUMENTS CONSIDERED TO BE RELEVANT**

Category*	Citation of document, with indication, where appropriate, of the relevant passages	Relevant to claim No.
Y	US 6708046 B1 (HISAMITSU TAKAGI) 16 March 2004 See column 5, lines 15-17, column 9, lines 5-7; claims 1, 6 and figures 2A-2B, 4, 7A-7B.	1-7,11-13,15
A		8-10,14
Y	US 2012-0046081 A1 (MARTIN RIDDIFORD et al.) 23 February 2012 See paragraph [0035] and figure 4.	1-7,11-13,15
A	US 2014-0185215 A1 (MICROSOFT CORPORATION) 03 July 2014 See paragraphs [0040]-[0071] and figures 1-11.	1-15
A	KR 10-2015-0082918 A (PREXCO CO., LTD.) 16 July 2015 See paragraphs [0026]-[0046] and figures 1-4.	1-15
A	KR 10-2015-0096827 A (SAMSUNG ELECTRONICS CO., LTD.) 26 August 2015 See paragraphs [0026]-[0072] and figures 1-10b.	1-15

 Further documents are listed in the continuation of Box C. See patent family annex.

\* Special categories of cited documents:

"A" document defining the general state of the art which is not considered to be of particular relevance

"E" earlier application or patent but published on or after the international filing date

"L" document which may throw doubts on priority claim(s) or which is cited to establish the publication date of another citation or other special reason (as specified)

"O" document referring to an oral disclosure, use, exhibition or other means

"P" document published prior to the international filing date but later than the priority date claimed

"T" later document published after the international filing date or priority date and not in conflict with the application but cited to understand the principle or theory underlying the invention

"X" document of particular relevance; the claimed invention cannot be considered novel or cannot be considered to involve an inventive step when the document is taken alone

"Y" document of particular relevance; the claimed invention cannot be considered to involve an inventive step when the document is combined with one or more other such documents, such combination being obvious to a person skilled in the art

"&amp;" document member of the same patent family

Date of the actual completion of the international search

24 November 2017 (24.11.2017)

Date of mailing of the international search report

**24 November 2017 (24.11.2017)**

Name and mailing address of the ISA/KR

International Application Division  
Korean Intellectual Property Office  
189 Cheongsa-ro, Seo-gu, Daejeon, 35208, Republic of Korea

Facsimile No. +82-42-481-8578

Authorized officer

LEE, Dong Wook

Telephone No. +82-42-481-8163

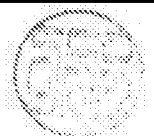

## INTERNATIONAL SEARCH REPORT

Information on patent family members

International application No.

**PCT/KR2017/008659**

Patent document cited in search report	Publication date	Patent family member(s)	Publication date
US 6708046 B1	16/03/2004	JP 2001-165144 A	19/06/2001
US 2012-0046081 A1	23/02/2012	CA 02743851 A1	20/02/2012
		CA 02782924 A1	26/02/2013
		CA 2743851 C	12/05/2015
		CA 2782924 C	03/01/2017
		CN 102193722 A	21/09/2011
		CN 102193722 B	19/08/2015
		EP 2421229 A2	22/02/2012
		EP 2421229 A3	25/04/2012
		EP 2421229 B1	25/12/2013
		EP 2528307 A1	28/11/2012
		EP 2528307 B1	02/04/2014
		EP 2562994 A1	27/02/2013
		EP 2562994 B1	30/07/2014
		JP 2011-191886 A	29/09/2011
		JP 5477640 B2	23/04/2014
		US 2011-0221782 A1	15/09/2011
		US 2012-0046076 A1	23/02/2012
		US 8660621 B2	25/02/2014
		US 8792947 B2	29/07/2014
US 2014-0185215 A1	03/07/2014	AU 2013-353498 A1	05/06/2014
		AU 2013-356688 A1	12/06/2014
		CA 02862621 A1	05/06/2014
		CA 02862624 A1	12/06/2014
		CN 103412616 A	27/11/2013
		CN 103412617 A	27/11/2013
		CN 103412617 B	07/12/2016
		CN 103412618 A	27/11/2013
		CN 103412632 A	27/11/2013
		CN 103412632 B	24/08/2016
		CN 103412639 A	27/11/2013
		CN 103412639 B	31/08/2016
		CN 103412651 A	27/11/2013
		CN 103412651 B	01/03/2017
		CN 103412659 A	27/11/2013
		CN 103440058 A	11/12/2013
		CN 103440058 B	13/07/2016
		CN 103455097 A	18/12/2013
		CN 103455098 A	18/12/2013
		CN 103455098 B	12/04/2017
		CN 103455149 A	18/12/2013
		CN 103455149 B	12/04/2017
		CN 103455150 A	18/12/2013
		CN 103455150 B	21/09/2016
		CN 103455151 A	18/12/2013
		CN 103455151 B	17/05/2017
		CN 103455274 A	18/12/2013

**INTERNATIONAL SEARCH REPORT**

Information on patent family members

International application No.

**PCT/KR2017/008659**

Patent document cited in search report	Publication date	Patent family member(s)	Publication date
		CN 103457592 A	18/12/2013
		CN 103457592 B	06/06/2017
		CN 103488252 A	01/01/2014
		CN 103488271 A	01/01/2014
		CN 104137025 A	05/11/2014
		CN 104160406 A	19/11/2014
		CN 104272221 A	07/01/2015
		CN 104969420 A	07/10/2015
		EP 2820501 A2	07/01/2015
		EP 2820503 A2	07/01/2015
		EP 2820504 A2	07/01/2015
		EP 2820505 A2	07/01/2015
		EP 2820506 A2	07/01/2015
		EP 2820507 A2	07/01/2015
		EP 2820510 A1	07/01/2015
		EP 2820511 A2	07/01/2015
		EP 2820512 A2	07/01/2015
		EP 2820515 A2	07/01/2015
		EP 2820516 A2	07/01/2015
		EP 2820517 A2	07/01/2015
		EP 2820518 A2	07/01/2015
		EP 2820519 A2	07/01/2015
		EP 2820520 A2	07/01/2015
		EP 2820521 A2	07/01/2015
		EP 2820552 A2	07/01/2015
		EP 2820590 A2	07/01/2015
		EP 2823433 A1	14/01/2015
		EP 2849861 A2	25/03/2015
		EP 2951893 A1	09/12/2015
		JP 2015-510205 A	02/04/2015
		JP 2015-512105 A	23/04/2015
		JP 2015-512106 A	23/04/2015
		JP 2015-512107 A	23/04/2015
		JP 2015-513148 A	30/04/2015
		JP 2015-513186 A	30/04/2015
		JP 2015-513744 A	14/05/2015
		JP 2015-513745 A	14/05/2015
		JP 2015-516612 A	11/06/2015
		JP 2015-517708 A	22/06/2015
		JP 2015-518189 A	25/06/2015
		JP 2015-518190 A	25/06/2015
		JP 2015-520838 A	23/07/2015
		JP 2016-507841 A	10/03/2016
		JP 2017-123200 A	13/07/2017
		JP 6135946 B2	31/05/2017
		JP 6161078 B2	12/07/2017
		JP 6175674 B2	09/08/2017
		JP 6175683 B2	09/08/2017
		KR 10-2014-0131345 A	12/11/2014
		KR 10-2014-0133537 A	19/11/2014

**INTERNATIONAL SEARCH REPORT**

Information on patent family members

International application No.

**PCT/KR2017/008659**

Patent document cited in search report	Publication date	Patent family member(s)	Publication date
		KR 10-2014-0134281 A	21/11/2014
		KR 10-2014-0136440 A	28/11/2014
		KR 10-2014-0136937 A	01/12/2014
		KR 10-2014-0138147 A	03/12/2014
		KR 10-2014-0138680 A	04/12/2014
		KR 10-2014-0138681 A	04/12/2014
		KR 10-2014-0138682 A	04/12/2014
		KR 10-2014-0140023 A	08/12/2014
		KR 10-2014-0140024 A	08/12/2014
		KR 10-2014-0145579 A	23/12/2014
		KR 10-2015-0013439 A	05/02/2015
		KR 10-2015-0110692 A	02/10/2015
		US 2013-0227836 A1	05/09/2013
		US 2013-0228023 A1	05/09/2013
		US 2013-0228433 A1	05/09/2013
		US 2013-0228434 A1	05/09/2013
		US 2013-0228435 A1	05/09/2013
		US 2013-0228439 A1	05/09/2013
		US 2013-0229100 A1	05/09/2013
		US 2013-0229335 A1	05/09/2013
		US 2013-0229347 A1	05/09/2013
		US 2013-0229350 A1	05/09/2013
		US 2013-0229351 A1	05/09/2013
		US 2013-0229354 A1	05/09/2013
		US 2013-0229356 A1	05/09/2013
		US 2013-0229363 A1	05/09/2013
		US 2013-0229366 A1	05/09/2013
		US 2013-0229380 A1	05/09/2013
		US 2013-0229386 A1	05/09/2013
		US 2013-0229534 A1	05/09/2013
		US 2013-0229568 A1	05/09/2013
		US 2013-0229570 A1	05/09/2013
		US 2013-0229756 A1	05/09/2013
		US 2013-0229757 A1	05/09/2013
		US 2013-0229758 A1	05/09/2013
		US 2013-0229759 A1	05/09/2013
		US 2013-0229760 A1	05/09/2013
		US 2013-0229761 A1	05/09/2013
		US 2013-0229762 A1	05/09/2013
		US 2013-0229773 A1	05/09/2013
		US 2013-0230346 A1	05/09/2013
		US 2013-0231755 A1	05/09/2013
		US 2013-0232280 A1	05/09/2013
		US 2013-0232348 A1	05/09/2013
		US 2013-0232349 A1	05/09/2013
		US 2013-0232350 A1	05/09/2013
		US 2013-0232353 A1	05/09/2013
		US 2013-0232571 A1	05/09/2013
		US 2013-0242495 A1	19/09/2013
		US 2013-0301199 A1	14/11/2013

**INTERNATIONAL SEARCH REPORT**

Information on patent family members

International application No.

**PCT/KR2017/008659**

Patent document cited in search report	Publication date	Patent family member(s)	Publication date
		US 2013-0301206 A1	14/11/2013
		US 2013-0322000 A1	05/12/2013
		US 2013-0322001 A1	05/12/2013
		US 2014-0012401 A1	09/01/2014
		US 2014-0031463 A1	30/01/2014
		US 2014-0043275 A1	13/02/2014
		US 2014-0048399 A1	20/02/2014
		US 2014-0119802 A1	01/05/2014
		US 2014-0132550 A1	15/05/2014
		US 2014-0185220 A1	03/07/2014
		US 2014-0204514 A1	24/07/2014
		US 2014-0204515 A1	24/07/2014
		US 2014-0247546 A1	04/09/2014
		US 2014-0291134 A1	02/10/2014
		US 2014-0362506 A1	11/12/2014
		US 2014-0379942 A1	25/12/2014
		US 2015-0036274 A1	05/02/2015
		US 2015-0227212 A1	13/08/2015
		US 2015-0234478 A1	20/08/2015
		US 2015-0261262 A1	17/09/2015
		US 2015-0311014 A1	29/10/2015
		US 2015-0378392 A1	31/12/2015
		US 2016-0124467 A1	05/05/2016
		US 2016-0209884 A1	21/07/2016
		US 2016-0299537 A1	13/10/2016
		US 2016-0306396 A1	20/10/2016
		US 2016-0357295 A9	08/12/2016
		US 2017-0177038 A1	22/06/2017
		US 8498100 B1	30/07/2013
		US 8543227 B1	24/09/2013
		US 8548608 B2	01/10/2013
		US 8564944 B2	22/10/2013
		US 8570725 B2	29/10/2013
		US 8610015 B2	17/12/2013
		US 8614666 B2	24/12/2013
		US 8646999 B2	11/02/2014
		US 8699215 B2	15/04/2014
		US 8719603 B2	06/05/2014
		US 8724302 B2	13/05/2014
		US 8780540 B2	15/07/2014
		US 8780541 B2	15/07/2014
		US 8791382 B2	29/07/2014
		US 8830668 B2	09/09/2014
		US 8850241 B2	30/09/2014
		US 8854799 B2	07/10/2014
		US 8873227 B2	28/10/2014
		US 8896993 B2	25/11/2014
		US 8903517 B2	02/12/2014
		US 8935774 B2	13/01/2015
		US 8947864 B2	03/02/2015

**INTERNATIONAL SEARCH REPORT**

Information on patent family members

International application No.

**PCT/KR2017/008659**

Patent document cited in search report	Publication date	Patent family member(s)	Publication date
		US 9047207 B2	02/06/2015
		US 9064654 B2	23/06/2015
		US 9075566 B2	07/07/2015
		US 9098117 B2	04/08/2015
		US 9111703 B2	18/08/2015
		US 9116550 B2	25/08/2015
		US 9134807 B2	15/09/2015
		US 9134808 B2	15/09/2015
		US 9146620 B2	29/09/2015
		US 9158383 B2	13/10/2015
		US 9158384 B2	13/10/2015
		US 9176900 B2	03/11/2015
		US 9176901 B2	03/11/2015
		US 9268373 B2	23/02/2016
		US 9275809 B2	01/03/2016
		US 9298236 B2	29/03/2016
		US 9304948 B2	05/04/2016
		US 9304949 B2	05/04/2016
		US 9360893 B2	07/06/2016
		US 9411751 B2	09/08/2016
		US 9426905 B2	23/08/2016
		US 9460029 B2	04/10/2016
		US 9465412 B2	11/10/2016
		US 9618977 B2	11/04/2017
		US 9619071 B2	11/04/2017
		US 9678542 B2	13/06/2017
		US 9706089 B2	11/07/2017
		US 9710093 B2	18/07/2017
		US 9766663 B2	19/09/2017
		WO 2013-131106 A1	06/09/2013
		WO 2013-134438 A1	12/09/2013
		WO 2013-173385 A2	21/11/2013
		WO 2013-173385 A3	12/09/2014
		WO 2013-188318 A1	19/12/2013
		WO 2014-084872 A2	05/06/2014
		WO 2014-084872 A3	14/08/2014
		WO 2014-084873 A2	05/06/2014
		WO 2014-084873 A3	04/09/2014
		WO 2014-084874 A2	05/06/2014
		WO 2014-084874 A3	14/08/2014
		WO 2014-084875 A2	05/06/2014
		WO 2014-084875 A3	21/08/2014
		WO 2014-084876 A2	05/06/2014
		WO 2014-084876 A3	04/09/2014
		WO 2014-084877 A2	05/06/2014
		WO 2014-084877 A3	07/08/2014
		WO 2014-084878 A2	05/06/2014
		WO 2014-084878 A3	07/08/2014
		WO 2014-084879 A2	05/06/2014
		WO 2014-084879 A3	28/08/2014

**INTERNATIONAL SEARCH REPORT**

Information on patent family members

International application No.

**PCT/KR2017/008659**

Patent document cited in search report	Publication date	Patent family member(s)	Publication date
		WO 2014-084880 A2	05/06/2014
		WO 2014-084880 A3	28/08/2014
		WO 2014-084881 A2	05/06/2014
		WO 2014-084881 A3	12/09/2014
		WO 2014-084882 A2	05/06/2014
		WO 2014-084882 A3	12/09/2014
		WO 2014-088612 A2	12/06/2014
		WO 2014-088612 A3	28/08/2014
		WO 2014-088613 A2	12/06/2014
		WO 2014-088613 A3	12/09/2014
		WO 2014-088614 A2	12/06/2014
		WO 2014-088614 A3	12/09/2014
		WO 2014-088615 A2	12/06/2014
		WO 2014-088615 A3	12/09/2014
		WO 2014-088616 A2	12/06/2014
		WO 2014-088616 A3	21/08/2014
		WO 2014-088617 A2	12/06/2014
		WO 2014-088617 A3	28/08/2014
		WO 2014-120966 A1	07/08/2014
KR 10-2015-0082918 A	16/07/2015	KR 10-1614826 B1	22/04/2016
KR 10-2015-0096827 A	26/08/2015	US 2015-0233162 A1	20/08/2015
		US 9250733 B2	02/02/2016