

(19) World Intellectual Property Organization
International Bureau



(43) International Publication Date
3 January 2008 (03.01.2008)

PCT

(10) International Publication Number
WO 2008/002320 A1

- (51) International Patent Classification:
G02F 1/13357 (2006.01) H01J 31/12 (2006.01)
H01J 9/22 (2006.01)
- (21) International Application Number:
PCT/US2006/038827
- (22) International Filing Date: 4 October 2006 (04.10.2006)
- (25) Filing Language: English
- (26) Publication Language: English
- (30) Priority Data:
60/817,241 28 June 2006 (28.06.2006) US
- (71) Applicant (for all designated States except US): THOMSON LICENSING [FR/FR]; 46 Quai A. Le Gallo, F-92100 Boulogne-Billancourt (FR).
- (72) Inventors; and
- (75) Inventors/Applicants (for US only): GOROG, Istvan [US/US]; 1275 Wheatland Avenue, Lancaster, PA 17603

(US). RITT, Peter Michael [US/US]; 2356 Split Rail Drive, East Petersburg, PA 17520 (US).

(74) Agents: LAKS, Joseph, J. et al.; Thomson Licensing, Two Independence Way, Suite # 200, Princeton, New Jersey 08540 (US).

(81) Designated States (unless otherwise indicated, for every kind of national protection available): AE, AG, AL, AM, AT, AU, AZ, BA, BB, BG, BR, BW, BY, BZ, CA, CH, CN, CO, CR, CU, CZ, DE, DK, DM, DZ, EC, EE, EG, ES, FI, GB, GD, GE, GH, GM, HN, HR, HU, ID, IL, IN, IS, JP, KE, KG, KM, KN, KP, KR, KZ, LA, LC, LK, LR, LS, LT, LU, LV, LY, MA, MD, MG, MK, MN, MW, MX, MY, MZ, NA, NG, NI, NO, NZ, OM, PG, PH, PL, PT, RO, RS, RU, SC, SD, SE, SG, SK, SL, SM, SV, SY, TJ, TM, TN, TR, TT, TZ, UA, UG, US, UZ, VC, VN, ZA, ZM, ZW.

(84) Designated States (unless otherwise indicated, for every kind of regional protection available): ARIPO (BW, GH, GM, KE, LS, MW, MZ, NA, SD, SL, SZ, TZ, UG, ZM, ZW), Eurasian (AM, AZ, BY, KG, KZ, MD, RU, TJ, TM), European (AT, BE, BG, CH, CY, CZ, DE, DK, EE, ES, FI,

[Continued on next page]

(54) Title: LIQUID CRYSTAL DISPLAY HAVING A FIELD EMISSION BACKLIGHT

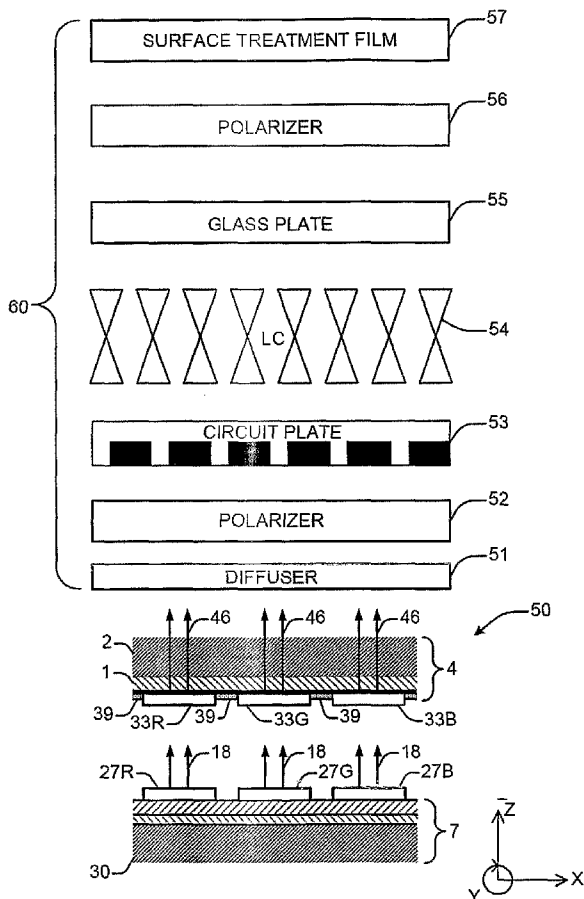

(57) Abstract: An LCD display has a programmable backlight device that produces multiple different color fields from multiple different phosphor elements. The backlight device can be a low resolution FED device. The phosphor is applied by an electrophotographic screening process or direct electrostatic screening process. The FED device can further incorporate a wide gamut phosphor.

WO 2008/002320 A1



FR, GB, GR, HU, IE, IS, IT, LT, LU, LV, MC, NL, PL, PT,
RO, SE, SI, SK, TR), OAPI (BF, BJ, CF, CG, CI, CM, GA,
GN, GQ, GW, ML, MR, NE, SN, TD, TG).

— *with amended claims*

Published:

— *with international search report*

For two-letter codes and other abbreviations, refer to the "Guidance Notes on Codes and Abbreviations" appearing at the beginning of each regular issue of the PCT Gazette.

LIQUID CRYSTAL DISPLAY HAVING A FIELD EMISSION BACKLIGHT

Related Applications

5 This application claims priority to United States Provisional Patent Application Serial No. 60/817,241 entitled "LCD with FED Backlight," filed on June 28, 2006, which is hereby incorporated by reference in its entirety.

Field of Invention

10

The invention relates to liquid crystal displays having intelligent backlighting.

Background of the Invention

15

Liquid crystal displays (LCDs) are in general light valves. Thus, to create an image they must be illuminated. The elementary picture areas (pixels, sub-pixels) are created by small area, electronically addressable, light shutters. In conventional LCD displays, color is generated by white light illumination and color filtering of the individual sub-pixel light transmissions that correspond to the individual Red, Green, and Blue sub-images. More advanced LCD displays provide

20 programmability of the backlight to allow motion blur elimination through scrolling of individual pulsed lights. For example, scrolling can be achieved by arranging a number of cold cathode fluorescent lamps such as the LCD display in U.S. Pat. No. 7,093,970 (having approximately 10 bulbs per display) in a manner such that the long axis of the lamps is along the horizontal axis of the display and the individual lamps are activated in approximate synchronism with the vertically

25 progressive addressing of the LCD displays. Alternatively, hot filament fluorescent bulbs can be employed and can likewise be scrolled, with the individual bulbs progressively turning on and off in a top-to-bottom, cyclic manner, whereby the scrolling can reduce motion artifacts. Known LCDs which can utilize scrolling can have a configuration similar to that shown in Fig. 1. The backlighting lamps 58 are positioned before a diffuser 51. Following the diffuser 51 is a polarizer 52 and a circuit

30 plate 53 having address circuits and associated first surface pixel electrodes on a first glass substrate plate. The device further includes the liquid crystal material (LC) 54 positioned after the circuit

plate 53. The LCD display also includes a second glass plate 55 supporting second surface electrodes, a color filter 59, a second polarizer 56 and a surface treatment film 57, as shown and ordered in Fig. 1.

A further improvement to the standard LCD technology can be obtained by utilizing LEDs (Light Emitting Diodes) for the backlights. By arranging such LEDs in a uniformly distributed manner behind the liquid crystal material and providing three sets of LEDs (Blue, Green, and Red) that comprise the entire backlighting system, additional programmability and additional performance gains can be obtained. Key features of such LED illuminators include superior black levels, enhanced dynamic range, and also the elimination of the color filter 59 indicated in Fig. 1. The color filter 59 can be eliminated by operating the backlight and the LCD in a color field sequential manner. While LED backlights can provide excellent image characteristics, their costs are high.

Brief Summary of the Invention

A liquid crystal display comprises a liquid crystal front end component and a field emission backlight component. The backlight can have one or more individual elements having different colors of phosphor. The plurality of individual elements are grouped into repeat units, where the display can have more than 10 repeat units. The backlight component is programmable and synchronized such that selected groups of the individual elements will activate in conjunction with activation of associated liquid crystal cells of the liquid crystal front end component. At least one of the individual elements can comprise a water incompatible phosphor such as a strontium thiogallate:europium phosphor to enhance the color gamut of the liquid crystal display. The plurality of individual elements can run in columns or rows. The ratio of individual columns or rows to the number of pixel lines of the LCD component is in the range of 1:3-1000. In a preferred embodiment, the ratio is 1:100-1000. The field emission backlight component can use a cathode comprising carbon nanotubes. The field emission backlight component can operate at an anode potential of 10-20 kV.

Brief Description of the Drawings

Fig. 1 is a sectional view of an existing LCD with backlight lamps;

Fig. 2 is a sectional view of an LCD with multicolor backlighting according to the invention;

Fig. 3 is a sectional view of a field emission device used for backlighting an LCD according
5 to the invention;

Fig. 4 is another sectional view of a field emission device used for backlighting an LCD
according to the invention;

Fig. 5 is a plan view of a plurality of phosphor elements in the field emission device
according to the invention;

Fig. 6 shows the CIE 1931 Chromaticity Diagram;

Fig. 7 shows a sectional view of the deposition of charged phosphor according to one direct
electrostatic process (DES) according to the invention;

Fig. 8 shows a sectional view of the deposition of charged phosphor according to another
direct electrostatic process (DES) of the invention;

Fig. 9 shows process steps following the deposition of charged phosphor according to one of
15 the direct electrostatic processes (DES); and

Fig. 10 shows a sectional view of the electrophotographic screening process (EPS) of
deposition of charged phosphor according to the invention.

Detailed Description of the Preferred Embodiments

An exemplary embodiment of the present invention will be described with reference to the
accompanying figures. Fig. 2 shows a cross sectional view of an exemplary LCD display having an
LCD front end component 60 and an FED backlight (or FED backlight component) 50. In the
25 exemplary embodiment, the individual phosphor elements 33 run in vertical stripes or patched as
shown in Fig. 5; however, the invention does include embodiments where the phosphor elements 33
run horizontally and where the phosphor elements of a given color run continuously. Figs. 3 and 4
show different cross sectional views of the FED backlight 50 according to the exemplary
embodiment of the invention. In the figures, the Y-axis is the vertical axis and the X-axis is the
30 horizontal axis. As will be described, having the individual phosphor elements permits intelligent
backlighting for the LCD.

The FED backlight 50 has a cathode 7 comprising a plurality of emitters 16 arranged in an array that emit electrons 18 due to an electric field created in the cathode 7. These electrons 18 are projected toward the anode 4. The anode 4 can comprise a glass substrate 2, having a transparent conductor 1 deposited thereon. The individual phosphor elements 33 can then be applied to the transparent conductor 1 and can be separated from one another. The transparent conductor 1 can be indium tin oxide. The phosphor elements 33 can comprise red phosphor (33R), green phosphor (33G), and blue phosphor (33B), as arranged Fig. 5.

The operation of the FED backlight 50 involves the electrons 18 from the plurality of emitters 16 in a cathode 7 striking phosphor elements 33 on an anode plate 4 and causing photon emission 46. A grouping of emitter cells 27R, 27G, 27B represented in Fig. 2 correspond to individual phosphor elements 33. Potential 15 is applied to the anode 4 during display operation. To emit electrons 18 from particular array emitter apertures 25, a gate potential V_q is applied to specific gates 26 which may be supported on dielectric material 28. As shown in Figs. 3 and 4, a plurality of gates 26 (and consequently a plurality of emitter cells) can be used in one phosphor element 33.

The dielectric material 28 and electron emitters 16 can be supported on a cathode assembly 31 which can be supported on a cathode back plate 29, which in turn is supported on back plate support structure 30.

The brightness of the FED backlight 50 can be greatly enhanced by the presence of thin, reflective metal film 21 on the cathode side of the phosphor. Essentially, the reflective metal film 21 can double the light 46 observed by the viewer. The reason is that the reflective metal film 21 reflects the portion of the light emitted toward the cathode plate so that upon reflection it propagates away from the cathode 7 toward the viewer.

Fig. 2 shows an exemplary embodiment of the LCD display utilizing the FED 50 shown in Figs. 3-5. Here the FED backlights 50 are positioned before a diffuser 51. The LCD display according to the invention is generally intended to include the diffuser 51. Following the diffuser 51 is a polarizer 52 and a circuit plate 53. The diffuser 51 and polarizer stack may include additional brightness enhancement elements such as a Vikuiti™ optical film made by 3M which increases the brightness of liquid crystal displays (LCDs) by recycling otherwise unused light (such as that is absorbed by the polarizer) and optimizing the angle of the light incident on the liquid crystal. The LCD further includes the liquid crystal materials (LC) 54 positioned after the circuit plate 53. The

LCD display also includes a second glass plate 55, a second polarizer 56 and a surface treatment film 57, as shown and ordered in Fig.2. Regarding the emitters 16 shown in Figs. 3 and 4, they are shown as being conical microtips emitters. However, carbon nanotubes emitters are preferred.

Carbon nanotube cathodes can be effective in FEDs operating at anode potential of 10 kV or greater in the pixel resolution range of 1mm and larger. A low resolution FED with a coarse diffuser 51 provides a substantially locally uniform backlight for the LCD display. (Low resolution implies that a specific phosphor element or a specific repeat unit of phosphor elements are not exclusive to a specific LCD pixel.) A feature of the invention is that the plurality of the individual colors from the different phosphor elements 33 can pass through an individual LCD pixel having but one LCD cell, which can provide white light or green light, red light, blue light, or combinations thereof when appropriate phosphor elements 33 are activated and light therefrom is appropriately diffused in the vicinity of the LCD pixel.

A feature of the invention is that the backlight can be a programmable FED structure, which is referred to as being an intelligent backlight. This means that the FED can selectively provide specific colored light to specific regions on the screen. This is a benefit because the light is coordinated with the activation and deactivation of the various liquid crystal cell regions. By the FED backlights being programmable, the LCD can achieve good black levels, wide dynamic range, and blur-free motion rendition. Furthermore, it is desirable to provide a backlight having as large a color gamut as possible. These characteristics are most conveniently achieved by utilizing a low resolution FED as a backlight wherein the light-emitting phosphor materials incorporated into the FED are selected to provide a wide color gamut.

The novel Field Emission Device (FED) backlight surprisingly exhibits all the desirable characteristics of an LED, but at substantially lower cost. With the disclosed FEDs being programmable, they can operate in a color field sequential manner. While the FED structure shown in Fig. 2 includes a black matrix 39, a commercial quality LCD display with the FED is attainable without the black matrix. (The black matrix will, however, still provide some nominal improvement in black fields and in contrast.) Appropriate x-y addressing of the cathode plate allows programmable emission of electrons from a cold cathode, most conveniently constructed with carbon nanotube (CNT) technology. A key advantage of FEDs is that their programmability is achieved with low voltage and low current signals applied in an x-y matrix manner to the cathode structure. Furthermore, as a consequence of the inherent non-linearity of the field emission

phenomenon, no active devices are needed to be incorporated as switches at the x-y junctions. A further advantage of FEDs is that the power source for the emitted light is a simple DC power supply that in this application is preferably operated in the 10-20 kV range. A suitable FED for intelligent backlights may comprise 10-1,000 individually programmable rows and approximately the same number of columns. In the example FED shown in Fig. 5, each column has only one phosphor type and the phosphor colors cycle along each row. In this case, the system can have vertical programmability, wherein columns can be turned on in their entirety. Alternatively, each row may comprise a single phosphor color. In this case horizontal programmability is provided, wherein a row may be turned on in its entirety. For the backlight according to the invention, suitable pitches A (in Fig. 5) between the individual phosphor elements 33 can be dictated by the desired performance requirement of the LCD display. An example dimension of the pitch A can be several millimeters (e.g., 1-5 mm). As shown in Figs. 3 and 4, an individual phosphor element 33 can have a plurality of emitter cells each with array emitter apertures 25 having opening dimension B, as shown in Fig. 3. Suitable opening dimension B values can be about 10 microns. (The opening dimension B in Figs. 3 and 4 does not necessarily have to be the same value.) The pitch of emitter cells D can be around 15-30 microns. (The pitch of emitter cells D in Figs. 3 and 4 does not necessarily have to be the same value.) Regarding the spacing C between the anode plate 4 and the cathode plate 7, it turns out that a spacing C from 1 millimeter to several millimeters works very well for the FED in a backlight mode in the LCD display. Preferably, the spacing C is 1-5 mm, which helps to maintain a very thin display. The spreading of electrons due to space charge and emission angle associated with these spacings turns out to not be detrimental to the color performance of backlight when the pitch A is larger than about 1 mm. In other words, the LCD has a relatively low resolution requirement for the backlight when the intelligent backlighting is used. As such, electron spreading between the anode and the cathode plates is of no significant concern. The carbon nanotube FED can provide excellent light output subject to visible graininess due to emission non-uniformities. In the disclosed device, the undesirable consequences of such emission non-uniformities are rendered imperceptible through the use of an appropriate diffuser between the FED backlight and the liquid crystal device. Preferably the disclosed FED backlight is operated in the color sequential mode, thus no color filters are required; however, another embodiment of the invention can include color filters which could provide an opportunity for narrower color wavelength ranges. For example, in an FED backlight employing 300 individually addressable rows

one could assign 100 of these rows to each of the three colors - Red, Green, Blue, such that upon activating the appropriate control signals in a time sequential manner at any one time only the Red or the Green or the Blue phosphor elements from the anode plate are lit up. Fig. 5 shows an example array of the FED device in plan view of a hypothetical situation in which blue backlight is desired at a certain time in several rows of two adjacent colored groupings represented as first block 34 (i.e., Red 33R, Green 33G, Blue 33B and Red 33R', Green 33G', Blue 33B') and green backlighting is desired next in time in the same rows but the next two adjacent colored groupings represented as second block 35 (i.e., Red 33R'', Green 33G'', Blue 33B'' and Red 33R''', Green 33G''', Blue 33B'''). Note that in the example shown in Fig. 5, only 6 phosphor elements 33 in a column are shown as activated at a certain time; however, the LCD can be designed and operated to have the entire column or fraction thereof in the FED activated when such color is needed in a particular region of the screen in the LCD. The ratio of individual columns or rows of the individual phosphor elements 33 to the number of pixels lines of the LCD component according to the invention is in the range of 1:3-1000. In a preferred embodiment, the ratio is 1:100-1000. The ratio being between 1:100-1000 is preferred because it requires less individual electrical connections, but yet provides adequate backlight uniformity and programmability.

Another aspect of the invention is the selection of phosphor to be used in the FED backlight 50. It is desirable to provide the widest possible color gamut. Known FEDs utilize either low voltage phosphor materials or CRT phosphor materials. In the 10-15kV preferred operating range, CRT phosphor materials are the most suitable. Different phosphor materials and their characteristics are indicated in the following table.

Type	Phosphor	x	y	lm/wv	Decay (s)	NTSC space (%)	Comments
NTSC Green	Zn ₂ SiO ₄ :Mn (Zinc Orthosilicate-Magnanese)	0.21	0.71	31	10 ⁻²	100	Large color gamut and low efficacy
CRT Green	ZnS:Cu,Al,Au (Zinc Sulfide-Copper, Aluminum, Gold)	0.30	0.62	65	10 ⁻⁵	70	High efficacy EBU - skin tones
Alternative Green	SrGa ₂ S ₄ :Eu (Strontium Thiogallate:Europium)	0.27	0.68	55	10 ⁻⁵	85	Good gamut; high current saturation; moisture sensitive
CRT Blue	ZnS:Ag (Zinc Sulfide-Silver)	0.14	0.05	10	10 ⁻⁵	100	High efficacy; pigment added
CRT Red	Y ₂ O ₂ S:Eu (Yttrium oxysulfate-europium)	0.66	0.33	16	10 ⁻³	100	High efficacy; pigment added

The NTSC phosphor materials provide substantially wider color gamut than do CRT

phosphor materials. This is shown in the CIE 1931 Chromaticity Diagram in Fig. 6. But as shown in the table, the efficiency of the NTSC Green phosphor is less than 50% of the CRT Green phosphor. Furthermore, the NTSC Green has a long decay time. Thus it may result in a motion delay. Therefore, the TV industry has completely switched from the original NTSC Green to the CRT Green.

An alternative Green phosphor, strontium thiogallate:europium, has been identified. The CIE 1931 Chromaticity Diagram shown in Fig. 6 shows that strontium thiogallate:europium provides a color gamut exceeding that of CRT Green and approaching that of the NTSC Green. The negative aspect of strontium thiogallate:europium phosphor is that it is moisture-sensitive (i.e., chemically decomposes by water). Therefore, such a phosphor cannot be applied with the standard commercial screening techniques, because they require the use of water. As such, strontium thiogallate:europium phosphor could not be considered.

However, another aspect of the invention provides the means to include non-water compatible phosphor. Two novel electrostatic techniques for screening water-incompatible phosphor are herein disclosed for FEDs. One is an electrophotographic screening process (EPS) and the other is a direct electrostatic screening process (DES).

One direct electrostatic process (DES) can be best understood with reference to Fig. 7. The process can begin with the application of a conductor on the glass surface. Fig. 7 shows an unfinished anode plate 4 having the conductor 1 on glass substrate 2. The conductor 1 can be made either by the deposition of a thin layer of metal (e.g. rhodium) or an organic conductor. In the case where an inorganic conductor will remain inside the FED structure after subsequent processing and/or finishing, the conductor must be transparent. In case of an organic conductor, one can bake out the organic conductor in subsequent processing steps; as such, transparency is not required for such conductors.

Next, the process involves placing an electrostatic mask 12 having apertures 13 positioned some distance in front of the glass substrate 2. The dimension of the apertures 13 can be approximately the desired dimension of the phosphor stripes (i.e. the width of the 33R, 33B and 33G such as shown in Figs. 2 and 5). Approximately implies the aperture 13 dimensions are about +/- 20% the size of the target width of the phosphor stripe. A bias voltage between the electrostatic mask and the conductor coating the substrate is then applied. The bias voltage will result in an electric field indicated by arrows and the associated letter "E" in Fig. 7. A flux of charged phosphor

particles 11 in a chamber 20 (which can be a closed box structure having appropriate plumbing for piping in the flux) is then caused to move toward the substrate 2 and its associated electrostatic mask 12. As such, the flux is introduced to the chamber 20 on the side of the mask opposite of the glass substrate. The phosphor particles 11 have a charge similar to the electrostatic mask. As the phosphor particles 11 approach the mask, the particles will be guided by the fringing electric fields away from the solid surface of the mask 12 and through the aperture 13 such that they will be deposited on top of the conductor 1 underneath the aperture 13. The process steps outlined above are done for a first color phosphor. To apply other phosphor of different color, another electrostatic mask 12 can replace the first mask and be appropriately positioned to apply the next flux of phosphor particles of another color. Alternatively, the existing electrostatic mask 12 used for depositing the first color phosphor can be appropriately shifted to deposit the next color phosphor in the targeted locations for that second color.

Fig. 8 shows an alternative DES arrangement. The fundamental difference between the arrangement shown in Fig. 7 and that in Fig. 8 is the inclusion of an insulator layer 3 on top of the conductor 2 on the substrate. Fundamentally, the arrangement shown in Fig. 8 functions similarly to that shown in Fig. 7, except that here in Fig. 8 the phosphor particles 11 which have a charge and propagate through the apertures 13 of the electrostatic mask 12 will retain their charge as they deposit on the insulator 3, because they are separated from the underlying conductor 1 by the insulator 3. With the insulator 3, the process steps can be the same as those used in the application of phosphor particles 11 shown and described in Fig. 7.

By the inclusion of an insulator 3, another printing process is feasible. This other process which involves charging the insulator 3 through the apertures 13 of the electrostatic mask 11 with corona charges. The locations on the insulator that were aligned with the apertures 13 will now have a charge. Phosphor particles 11 having charge could then be introduced in the chamber and will deposit on the location of the conductor having the opposition charge of the phosphor particles 11.

The inclusion of an insulator 3 can also be advantageously utilized in a fixing step. The drawings in Fig. 9 show the various stages of the process according the embodiments having insulator and a fixing step. Fig. 9A shows a profile of the anode plate 4 following the deposition of three phosphor deposits and removal of the electrostatic mask. Fig. 9B shows the result of a fixing step. The fixing can occur by applying some solvent that partially dissolves the insulator, thereby allowing the phosphor particles to sink into the insulator 3 and allowing some of the insulator

material through capillary action to diffuse up and into the phosphor. After the solvent evaporates, the result is that the phosphor deposits are now more strongly secured to the anode plate 4. Fixing helps to prevent unwanted movement of phosphor particles during a filming step. In a preferred embodiment the insulator is a polystyrene material of approximately 5-10 micrometers in thickness and the phosphor fixing is accomplished by spraying the anode plate with a solvent. Following the fixing step, a layer of lacquer film 5 can be applied to the anode plate, followed by the application a reflective metal film 21 as shown in Fig. 9C. After a bakeout step, the resulting structure of the anode plate 4 is shown in Fig. 9D, if no black matrix 39 is employed. If black matrix 39 is used it would be applied some time before the application of the reflective metal film 21 and the screen structure would resemble that structure shown in Fig. 2.

Alternatively, the phosphor elements can be deposited by an electrophotographic screening (EPS) process, which is generally shown in Fig. 10. The process begins by the application of an organic conductor film 41 as shown in Fig. 10A, followed by the application of an organic photoconductor film 42 as shown in Fig. 10B. The organic photoconductor film is then charged, preferably by a corona charger, which is represented in Fig. 10C. A mask 43 is then positioned by the screen. The mask 43 has apertures corresponding to the preferred locations of the phosphor elements. The organic photoconductor is then exposed to light which passes through the apertures of the mask 43 as shown in Fig. 10D. Areas of the organic photoconductor exposed to the light are discharged and regions not exposed remain charged. A flux of charged phosphor particles 11 in a chamber 20 (which can be a closed box structure having appropriate plumbing for piping in the flux) is then caused to move toward the substrate 2 and the charge phosphor particles 11 will then deposit on the regions of the organic photoconductor discharged as shown in Fig. 10E. (Alternatively, phosphor development can involve deposition of oppositely charged phosphor landing on appropriately charged locations of the organic photoconductor.) The steps of corona charging as shown in Fig. 10C, exposing and discharging as shown in 10D, and developing by the application of charged phosphor particles 11 can be repeated to deposit additional phosphor colors. When all of the desired color phosphor deposits are applied to the anode plate 4, the anode plate can then be fixed and filmed as represented in Fig. 10F. Following filming, a reflective metal film can be applied to the anode plate and the anode plate can be combined to a cathode plate 7 to complete the FED device. After the finishing of the FED, the FED is then joined to the back of the LCD to provide the backlighting for the LCD. The FED devices made according the processes disclosed

herein, can be also made for use as direct display devices, which do not involve liquid crystal front end components.

CLAIMS

5 1. A liquid crystal display comprising:
a liquid crystal front end component and
a field emission backlight component.

 2. The liquid crystal display of claim 1, wherein the field emission backlight
component has a plurality of individual elements of phosphor.

10 3. The liquid crystal display of claim 2, wherein the plurality of individual
elements are grouped into repeat units and the individual elements in the repeat units differ in
color.

15 4. The liquid crystal display of claim 3, wherein the individual elements of the
field emission backlight component are programmable and synchronized such that selected
groups of the individual elements will activate in conjunction with activation of associated
liquid crystal cells of the liquid crystal component.

20 5. The liquid crystal display of claim 2, wherein at least some of the individual
elements comprise a water incompatible phosphor.

 6. The liquid crystal display of claim 5, wherein one phosphor of the plurality of
individual elements is strontium thiogallate:europium.

25 7. The liquid crystal display of claim 2, wherein the individual elements of the
field emission backlight component are programmable and synchronized such that selected
groups of the individual elements will activate in conjunction with activation of associated
liquid crystal cells of the liquid crystal component.

8. The liquid crystal display of claim 3, wherein at least some of the individual elements comprise a water incompatible phosphor.

5 9. The liquid crystal display of claim 8, wherein one phosphor of the plurality of individual elements is strontium thiogallate:europium.

10. The liquid crystal display of claim 2, wherein the plurality of individual elements run in columns or rows.

10 11. The liquid crystal display of claim 10, wherein a ratio of individual columns or rows to the number of pixels lines is in the range of 1:3-1000.

15 12. The liquid crystal display of claim 10, wherein a ratio of individual columns or rows to the number of pixels lines is in the range of 1:100-1000.

20 13. The liquid crystal display of claim 11, wherein the individual elements of the field emission backlight component are programmable and synchronized such that selected groups of the individual elements will activate in conjunction with activation of associated liquid crystal cells of the liquid crystal component.

25 14. The liquid crystal display of claim 12, wherein the individual elements of the field emission backlight component are programmable and synchronized such that selected groups of the individual elements will activate in conjunction with activation of associated liquid crystal cells of the liquid crystal component.

15. The liquid crystal display of claim 3, wherein the field emission backlight component has 10 or more of the repeat units.

5 16. The liquid crystal display of claim 15, wherein the individual elements of the field emission backlight component are programmable and synchronized such that selected groups of the individual elements will activate in conjunction with activation of associated liquid crystal cells of the liquid crystal component.

10 17. The liquid crystal display of claim 2, wherein the field emission backlight component has a cathode comprising carbon nanotubes for emitting electrons which are to strike the phosphor of the plurality of individual elements.

15 18. The liquid crystal display of claim 17, wherein the plurality of individual elements are grouped into repeat units and the individual elements in the repeat units differ in color.

20 19. The liquid crystal display of claim 18, wherein the individual elements of the field emission backlight component are programmable and synchronized such that selected groups of the individual elements will activate in conjunction with activation of associated liquid crystal cells of the liquid crystal component.

25 20. The liquid crystal display of claim 19, wherein at least some of the individual elements comprise a water incompatible phosphor.

30 21. The liquid crystal display of claim 20, wherein one phosphor of the plurality of individual elements is strontium thiogallate:europium.

22. The liquid crystal display of claim 21, wherein the field emission backlight component operates at 10-20 kV.

23. The liquid crystal display of claim 15, wherein the field emission backlight component operates at 10-20 kV.

24. The liquid crystal display of claim 11, wherein the field emission backlight component operates at 10-20 kV.

25. The liquid crystal display of claim 13, wherein an anode plate and a cathode plate of the field emission backlight component have a spacing of 1-5 mm.

26. The liquid crystal display of claim 14, wherein an anode plate and a cathode plate of the field emission backlight component have a spacing of 1-5 mm.

27. A display comprising:
a liquid crystal component and
a field emission component for producing a plurality of colors.

28. The display of claim 27, wherein the field emission component has a plurality of individual elements of phosphor.

29. The liquid crystal display of claim 28, wherein the plurality of individual elements run in columns or rows.

30. The liquid crystal display of claim 29, wherein a ratio of individual columns or rows to the number of pixels lines is in the range of 1:3-1000.

31. The liquid crystal display of claim 29, wherein a ratio of individual columns or rows to the number of pixels lines is in the range of 1:100-1000.

32. The display of claim 27, wherein the field emission component is low resolution.

AMENDED CLAIMS

received by the International Bureau on 8 March 2007 (08.03.2007)

1. A liquid crystal display comprising:
a liquid crystal front end component and
a field emission backlight component, the field emission backlight component
5 being low resolution.
2. The liquid crystal display of claim 1, wherein the field emission
backlight component has a plurality of individual elements of phosphor.
- 10 3. The liquid crystal display of claim 2, wherein the plurality of
individual elements are grouped into repeat units and the individual elements in
the repeat units differ in color.
- 15 4. The liquid crystal display of claim 3, wherein the individual
elements of the field emission backlight component are programmable and
synchronized such that selected groups of the individual elements will activate in
conjunction with activation of associated liquid crystal cells of the liquid crystal
component.
- 20 5. The liquid crystal display of claim 2, wherein at least some of
the individual elements comprise a water incompatible phosphor.
- 25 6. The liquid crystal display of claim 5, wherein one phosphor of
the plurality of individual elements is strontium thiogallate:europium.
- 30 7. The liquid crystal display of claim 2, wherein the individual
elements of the field emission backlight component are programmable and
synchronized such that selected groups of the individual elements will activate in
conjunction with activation of associated liquid crystal cells of the liquid crystal
component.

8. The liquid crystal display of claim 3, wherein at least some of the individual elements comprise a water incompatible phosphor.

5 9. The liquid crystal display of claim 8, wherein one phosphor of the plurality of individual elements is strontium thiogallate:europium.

10 10. The liquid crystal display of claim 2, wherein the plurality of individual elements run in columns or rows.

11. The liquid crystal display of claim 10, wherein a ratio of individual columns or rows to the number of pixels lines is in the range of 1:3-1000.

15 12. The liquid crystal display of claim 10, wherein a ratio of individual columns or rows to the number of pixels lines is in the range of 1:100-1000.

20 13. The liquid crystal display of claim 11, wherein the individual elements of the field emission backlight component are programmable and synchronized such that selected groups of the individual elements will activate in conjunction with activation of associated liquid crystal cells of the liquid crystal component.

25 14. The liquid crystal display of claim 12, wherein the individual elements of the field emission backlight component are programmable and synchronized such that selected groups of the individual elements will activate in conjunction with activation of associated liquid crystal cells of the liquid crystal component.

30 15. The liquid crystal display of claim 3, wherein the field emission backlight component has 10 or more of the repeat units.

16. The liquid crystal display of claim 15, wherein the individual elements of the field emission backlight component are programmable and synchronized such that selected groups of the individual elements will activate in conjunction with activation of associated liquid crystal cells of the liquid crystal component.

5

17. The liquid crystal display of claim 2, wherein the field emission backlight component has a cathode comprising carbon nanotubes for emitting electrons which are to strike the phosphor of the plurality of individual elements.

10

18. The liquid crystal display of claim 17, wherein the plurality of individual elements are grouped into repeat units and the individual elements in the repeat units differ in color.

15

19. The liquid crystal display of claim 18, wherein the individual elements of the field emission backlight component are programmable and synchronized such that selected groups of the individual elements will activate in conjunction with activation of associated liquid crystal cells of the liquid crystal component.

20

20. The liquid crystal display of claim 19, wherein at least some of the individual elements comprise a water incompatible phosphor.

21. The liquid crystal display of claim 20, wherein one phosphor of the plurality of individual elements is strontium thiogallate:europium.

25

22. The liquid crystal display of claim 21, wherein the field emission backlight component operates at 10-20 kV.

23. The liquid crystal display of claim 15, wherein the field emission backlight component operates at 10-20 kV.

30

24. The liquid crystal display of claim 11, wherein the field emission backlight component operates at 10-20 kV.

5 25. The liquid crystal display of claim 13, wherein an anode plate and a cathode plate of the field emission backlight component have a spacing of 1-5 mm.

10 26. The liquid crystal display of claim 14, wherein an anode plate and a cathode plate of the field emission backlight component have a spacing of 1-5 mm.

27. A display comprising:
a liquid crystal component and
a field emission component for producing a plurality of colors, the field
15 emission component being low resolution.

28. The display of claim 27, wherein the field emission component has a plurality of individual elements of phosphor.

20 29. The liquid crystal display of claim 28, wherein the plurality of individual elements run in columns or rows.

25 30. The liquid crystal display of claim 29, wherein a ratio of individual columns or rows to the number of pixels lines is in the range of 1:3-1000.

30 31. The liquid crystal display of claim 29, wherein a ratio of individual columns or rows to the number of pixels lines is in the range of 1:100-1000.

32. The display of claim 27, wherein the field emission component is low resolution.

1/10

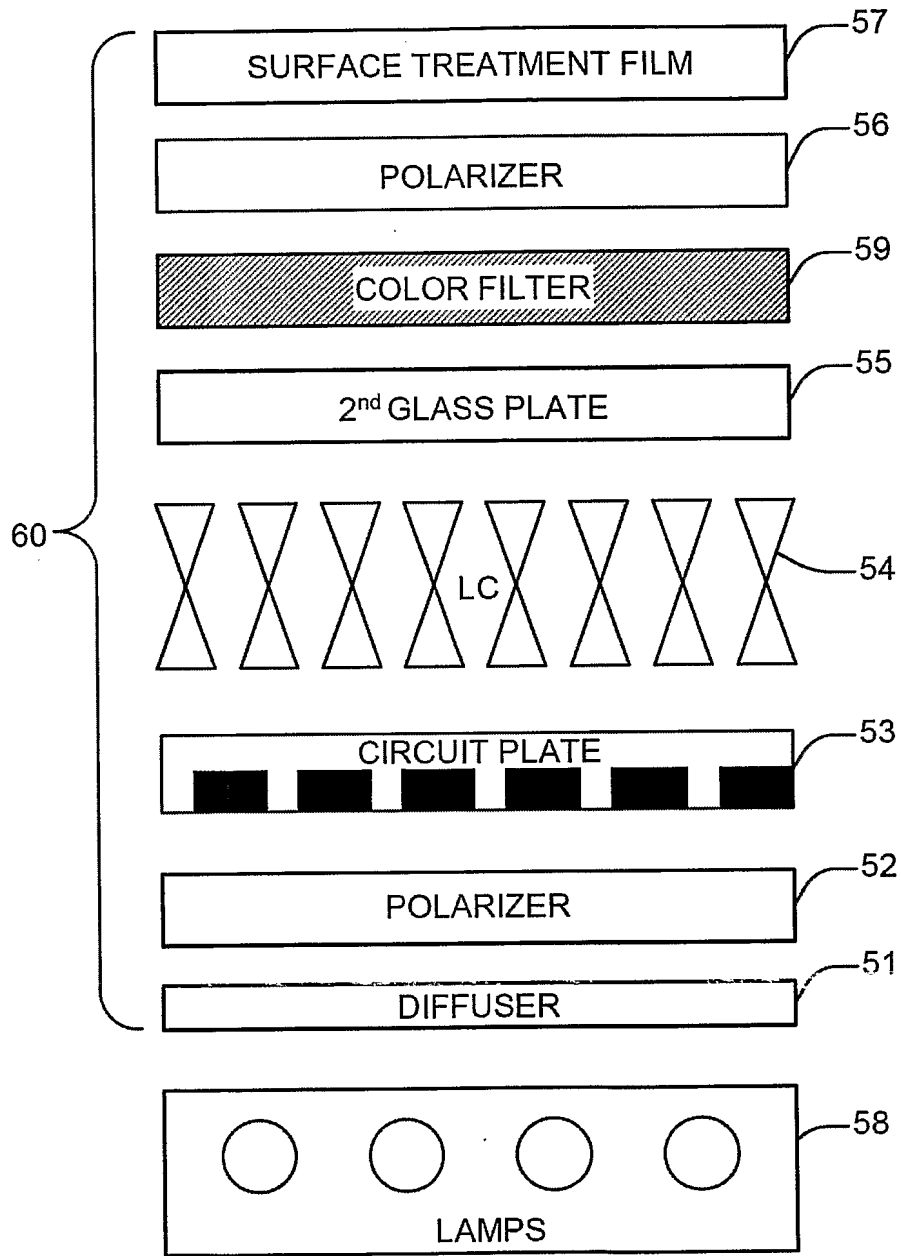

PRIOR ART

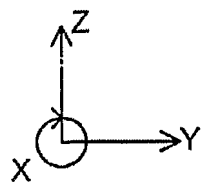

Fig. 1

2/10

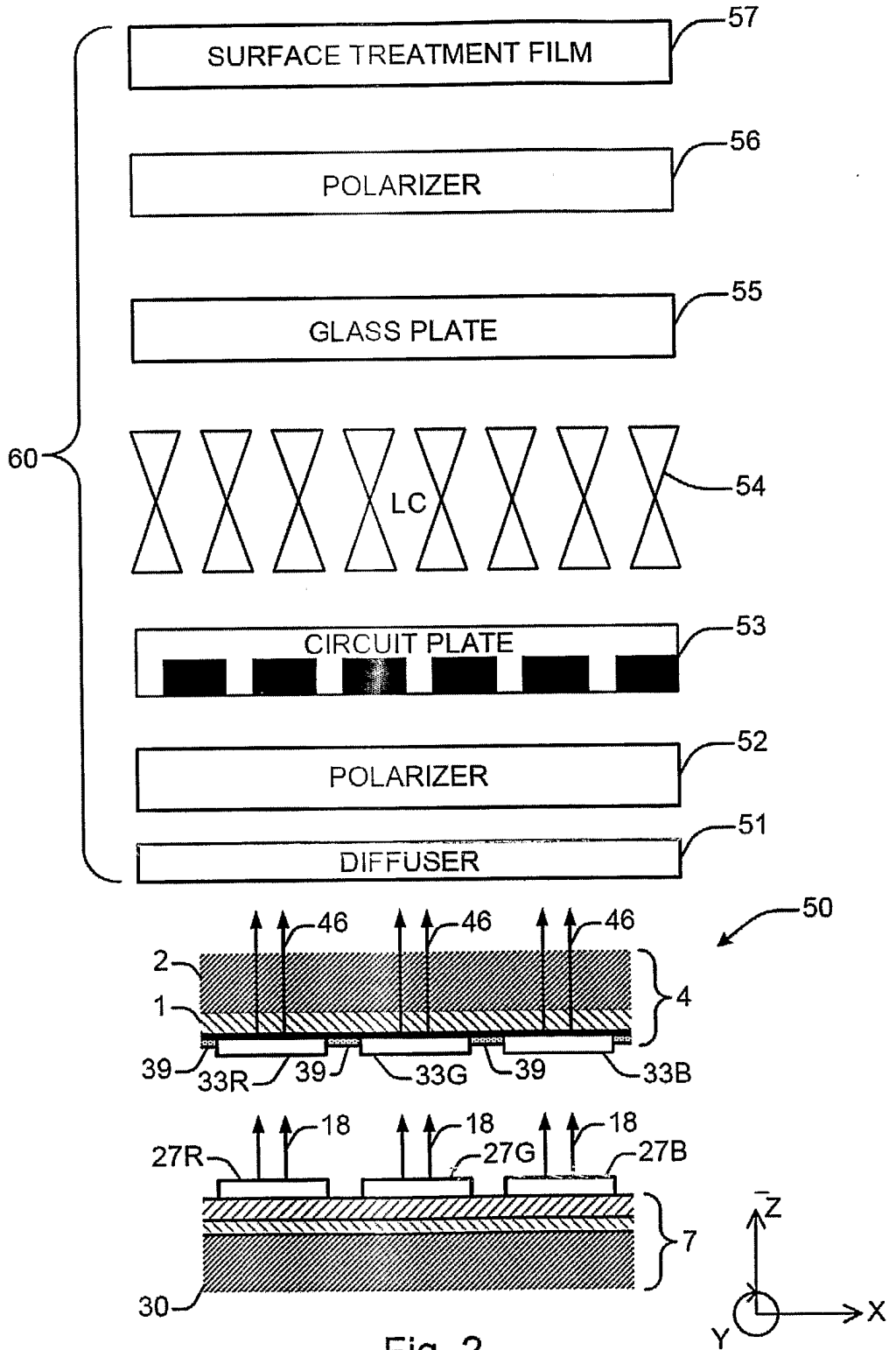

Fig. 2

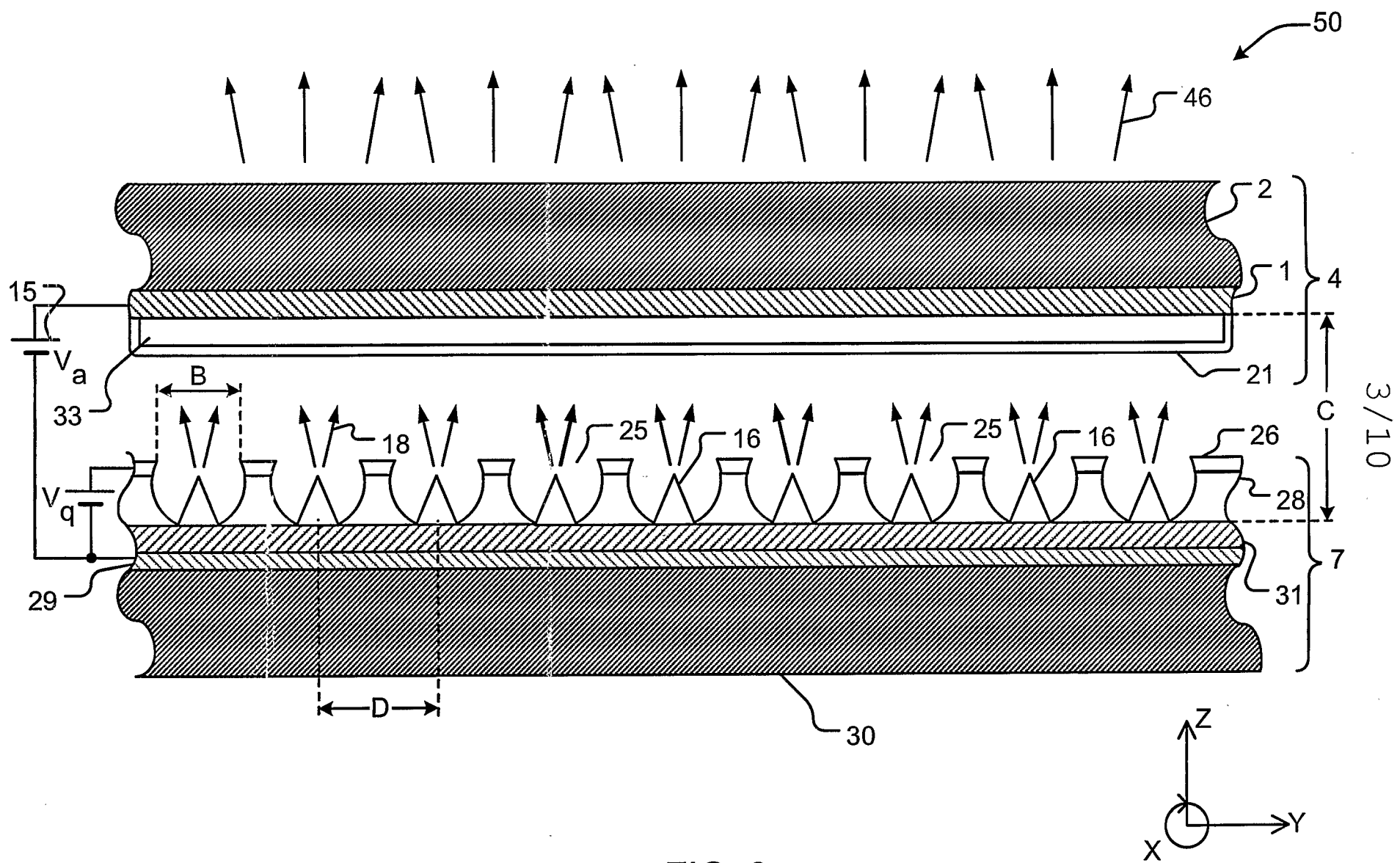

FIG. 3

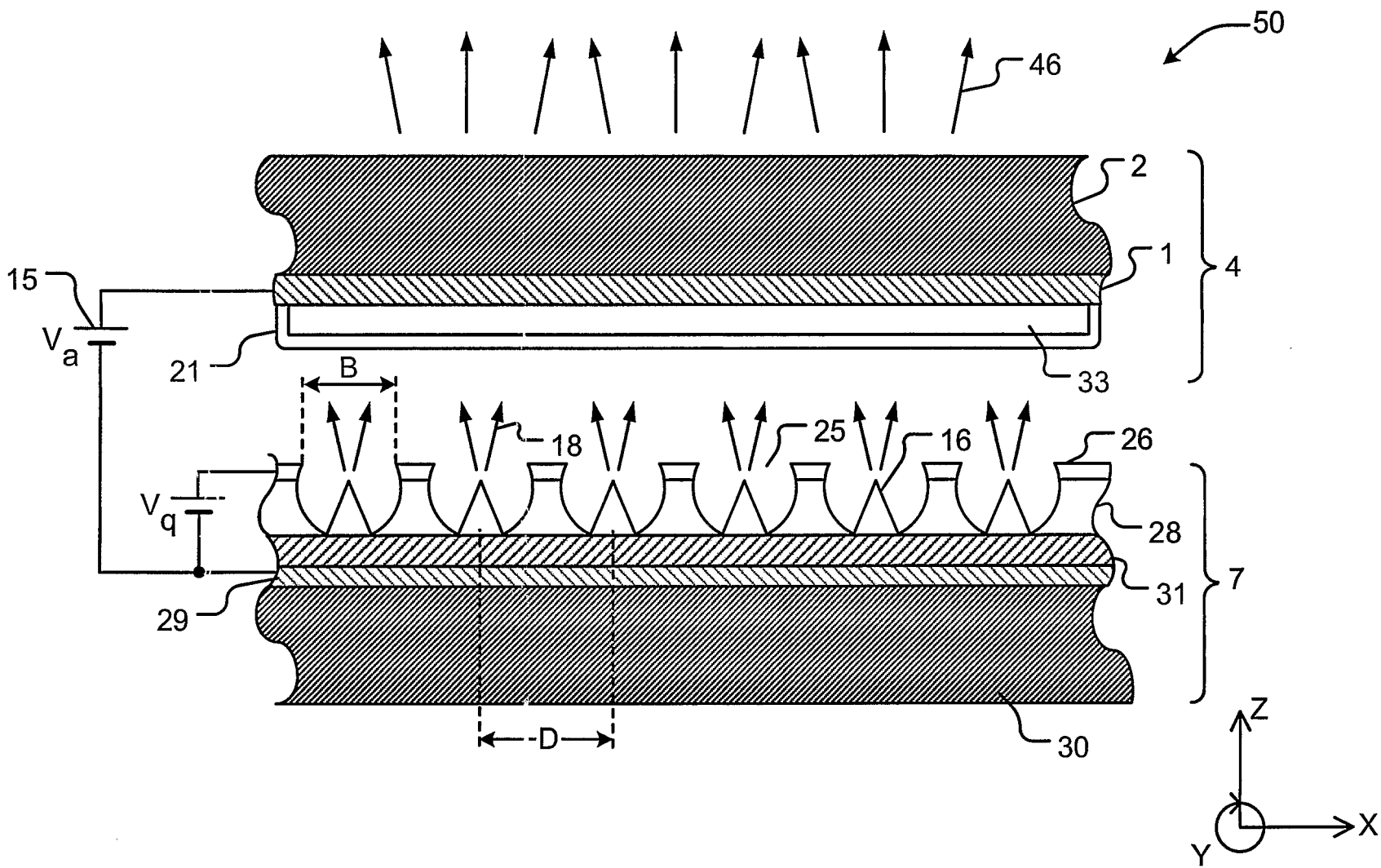

FIG. 4

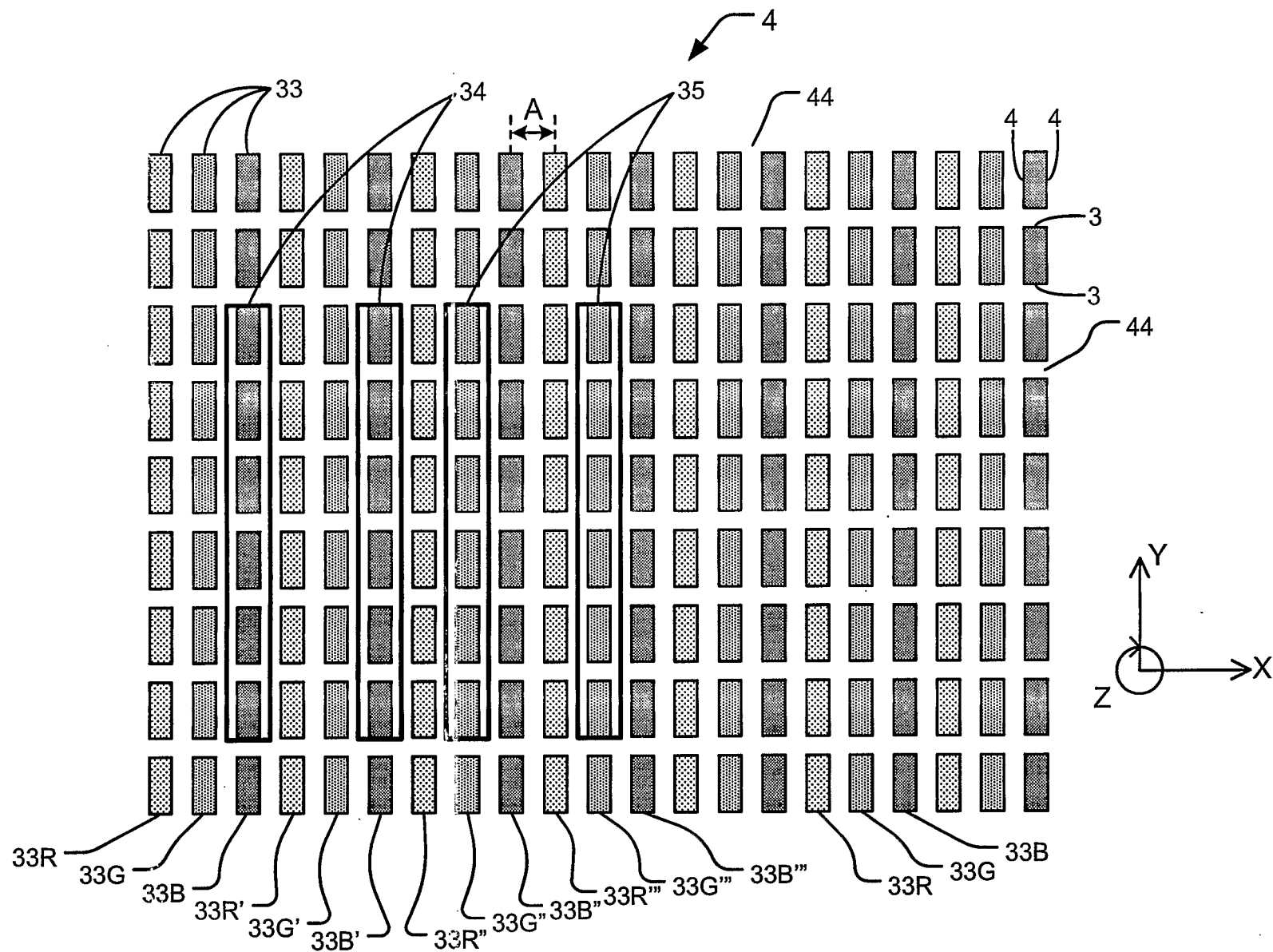

FIG. 5

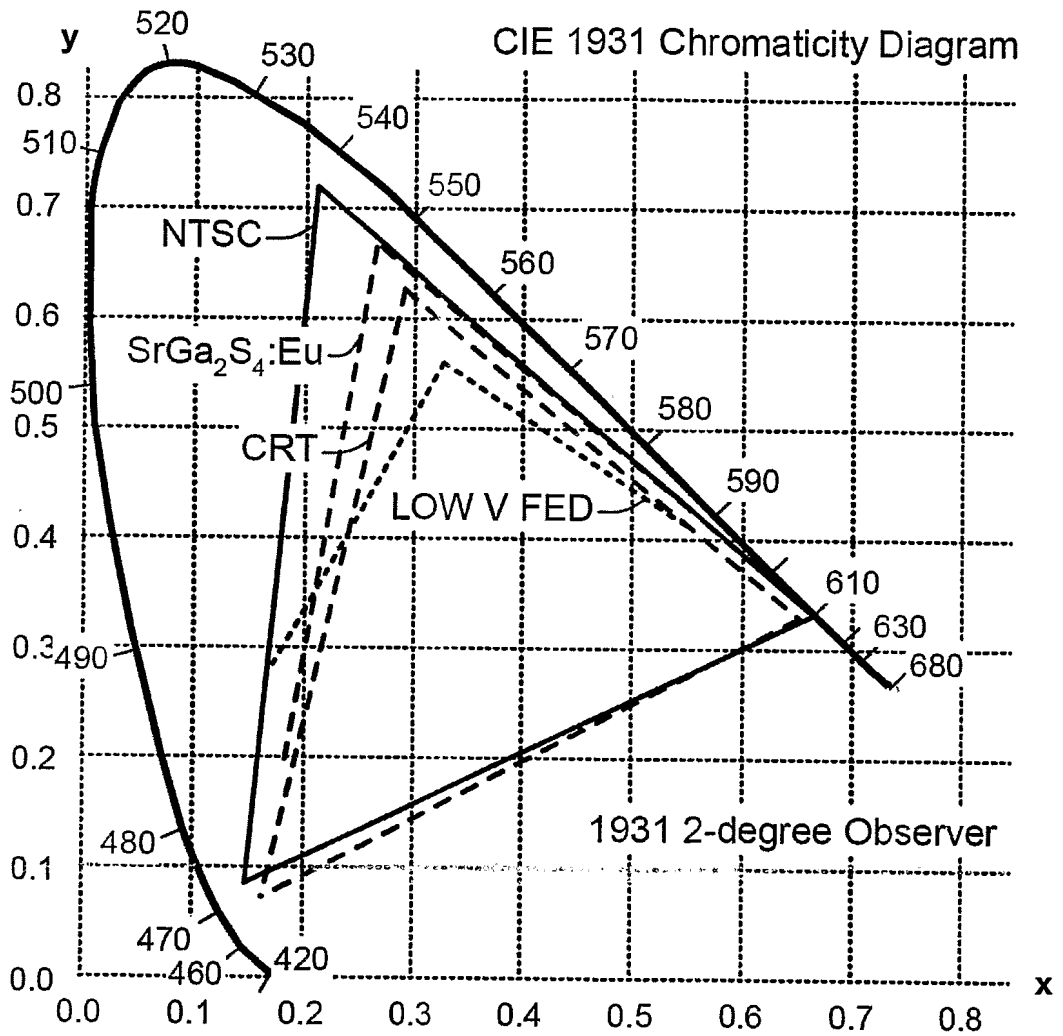

Fig. 6

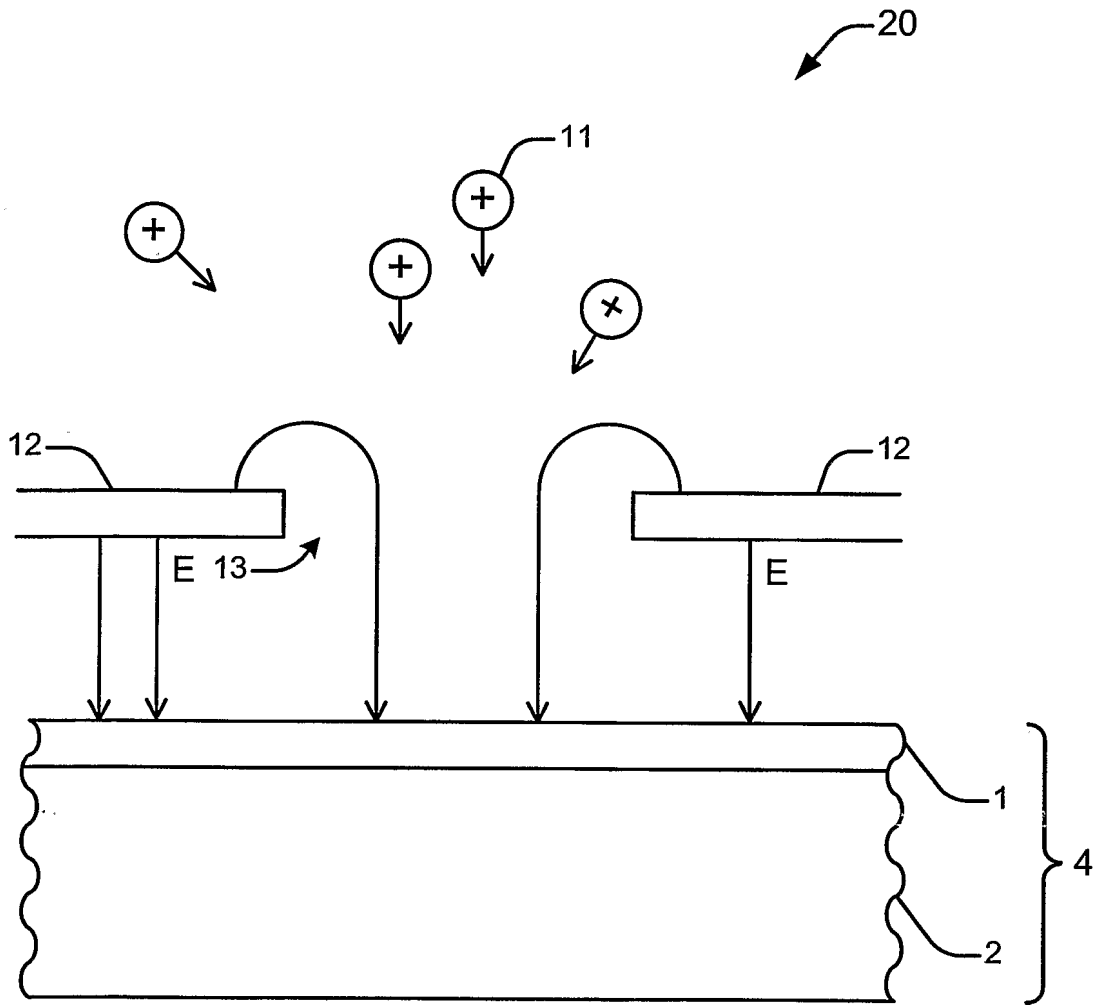

Fig. 7

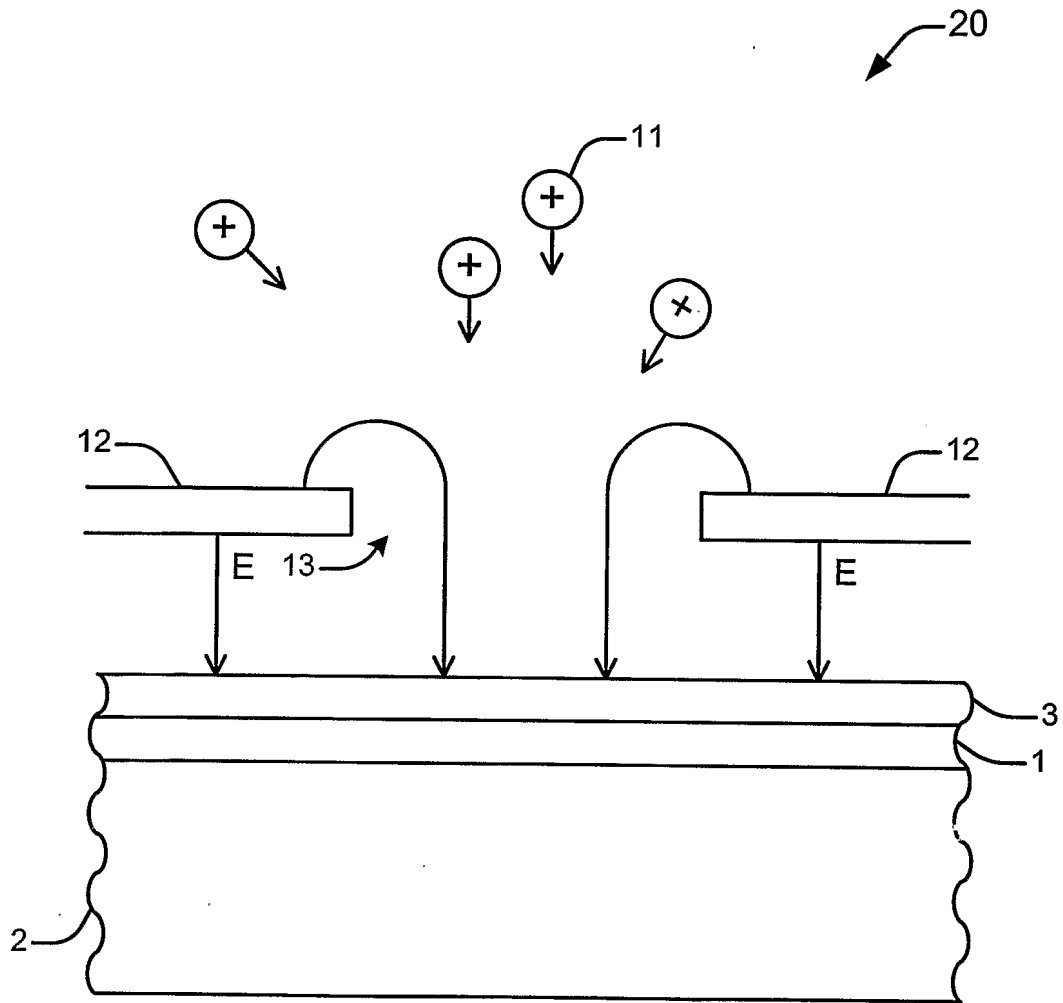

Fig. 8

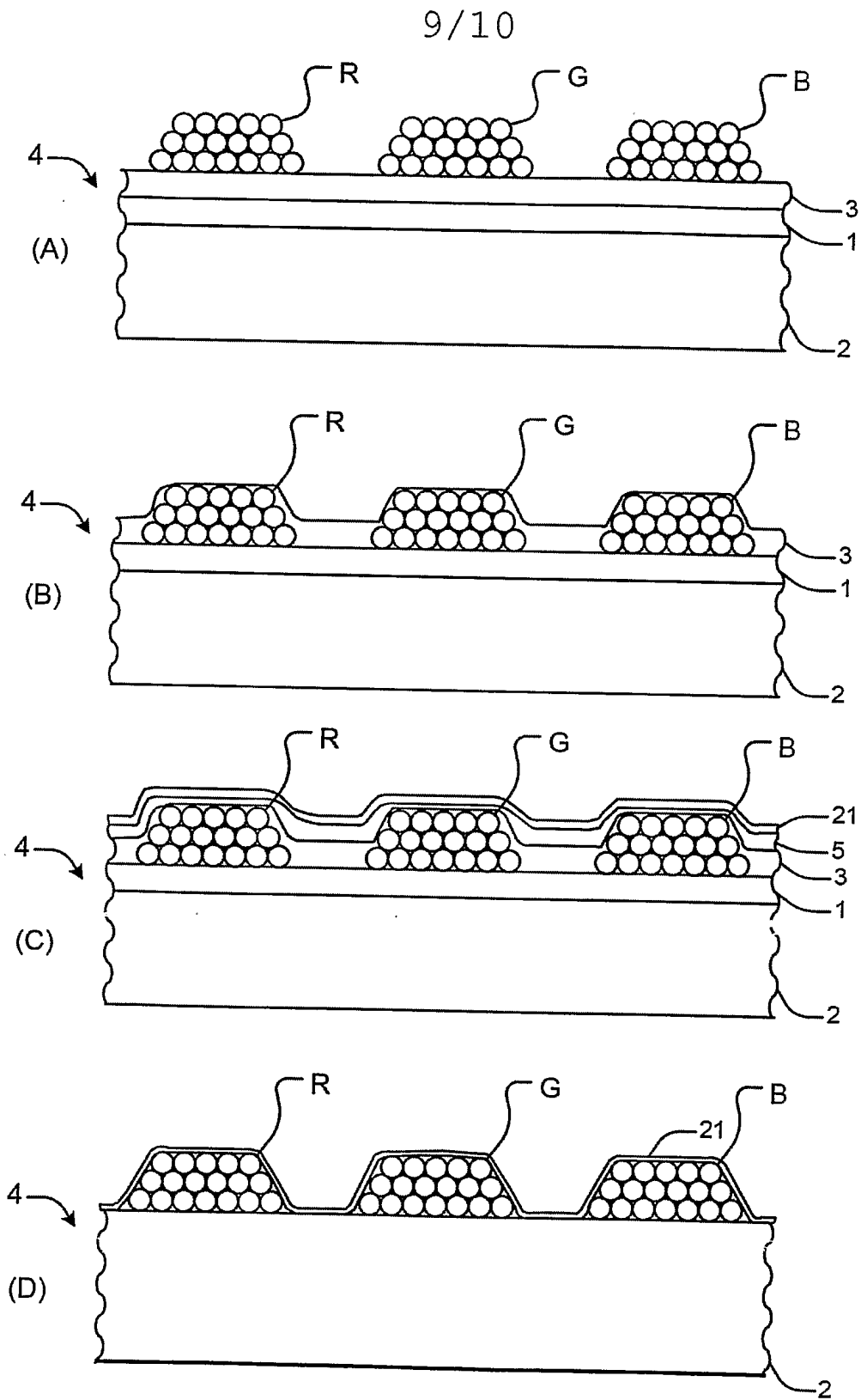

Fig. 9

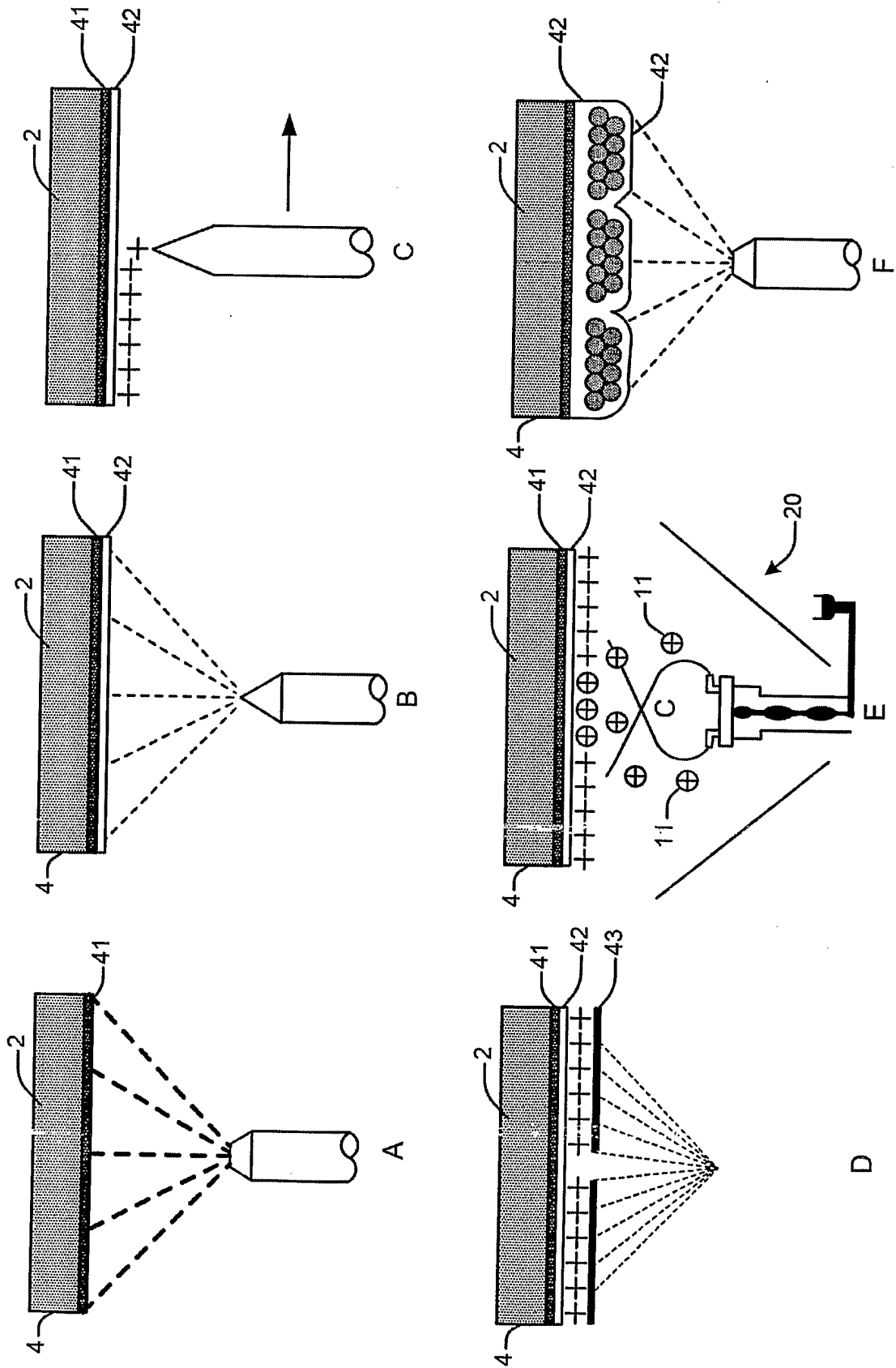

FIG. 10

INTERNATIONAL SEARCH REPORT

International application No

PCT/US2006/038827

A. CLASSIFICATION OF SUBJECT MATTER
 INV. G02F1/13357 H01J9/22 H01J31/12

According to International Patent Classification (IPC) or to both national classification and IPC

B. FIELDS SEARCHED

Minimum documentation searched (classification system followed by classification symbols)
 G02F H01J

Documentation searched other than minimum documentation to the extent that such documents are included in the fields searched

Electronic data base consulted during the international search (name of data base and, where practical, search terms used)

EPO-Internal, WPI Data, INSPEC, COMPENDEX, IBM-TDB

C. DOCUMENTS CONSIDERED TO BE RELEVANT

Category*	Citation of document, with indication, where appropriate, of the relevant passages	Relevant to claim No.
X	US 5 760 858 A (HODSON LESTER [US] ET AL) 2 June 1998 (1998-06-02)	1-4, 7, 10-16, 18, 19, 23-32
Y	column 7, line 12 - column 10, line 9; figures 1-5	5, 6, 8, 9, 17, 20, 21
X	US 2001/035922 A1 (PARK KWAN-SUN [KR] ET AL) 1 November 2001 (2001-11-01)	1-4, 7, 10-16, 18, 24-32
Y	paragraphs [0010] - [0012], [0030] - [0040]; figures 1-6 ----- -/--	17

Further documents are listed in the continuation of Box C.

See patent family annex.

* Special categories of cited documents :

- *A* document defining the general state of the art which is not considered to be of particular relevance
- *E* earlier document but published on or after the international filing date
- *L* document which may throw doubts on priority claim(s) or which is cited to establish the publication date of another citation or other special reason (as specified)
- *O* document referring to an oral disclosure, use, exhibition or other means
- *P* document published prior to the international filing date but later than the priority date claimed

- *T* later document published after the international filing date or priority date and not in conflict with the application but cited to understand the principle or theory underlying the invention
- *X* document of particular relevance; the claimed invention cannot be considered novel or cannot be considered to involve an inventive step when the document is taken alone
- *Y* document of particular relevance; the claimed invention cannot be considered to involve an inventive step when the document is combined with one or more other such documents, such combination being obvious to a person skilled in the art.
- *Z* document member of the same patent family

Date of the actual completion of the international search

16 January 2007

Date of mailing of the international search report

26/01/2007

Name and mailing address of the ISA/

European Patent Office, P.B. 5818 Patentlaan 2
 NL - 2280 HV Rijswijk
 Tel. (+31-70) 340-2040, Tx. 31 651 epo nl,
 Fax: (+31-70) 340-3016

Authorized officer

Kiernan, Laurence

INTERNATIONAL SEARCH REPORT

International application No

PCT/US2006/038827

C(Continuation). DOCUMENTS CONSIDERED TO BE RELEVANT

Category*	Citation of document, with indication, where appropriate, of the relevant passages	Relevant to claim No.
Y	SOURIAU J-C ET AL: "Cathodoluminescent properties of coated SrGa ₂ S ₄ :Eu ²⁺ and ZnS:Ag,Cl phosphors for field emission display applications" MATERIALS SCIENCE AND ENGINEERING B, ELSEVIER SEQUOIA, LAUSANNE, CH, vol. 76, no. 2, July 2000 (2000-07), pages 165-168, XP004205041 ISSN: 0921-5107 the whole document -----	5,6,8,9, 20,21
Y	US 2005/189517 A1 (HAMPDEN-SMITH MARK J [US] ET AL) 1 September 2005 (2005-09-01) paragraph [0255]; figures 39-41 -----	5,6,8,9, 20,21
A	US 6 353 286 B1 (TALIN ALBERT ALEC [US] ET AL) 5 March 2002 (2002-03-05) figure 1 -----	1,27

INTERNATIONAL SEARCH REPORT

Information on patent family members

International application No

PCT/US2006/038827

Patent document cited in search report		Publication date	Patent family member(s)	Publication date
US 5760858	A	02-06-1998	NONE	
US 2001035922	A1	01-11-2001	JP 2002055340 A KR 20010097947 A	20-02-2002 08-11-2001
US 2005189517	A1	01-09-2005	NONE	
US 6353286	B1	05-03-2002	NONE	