

S. R. McCONNELL.
 INTERNAL PIPE GRIPPER.
 APPLICATION FILED JAN. 23, 1913.

Patented Aug. 5, 1913.

1,069,560.

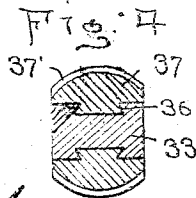
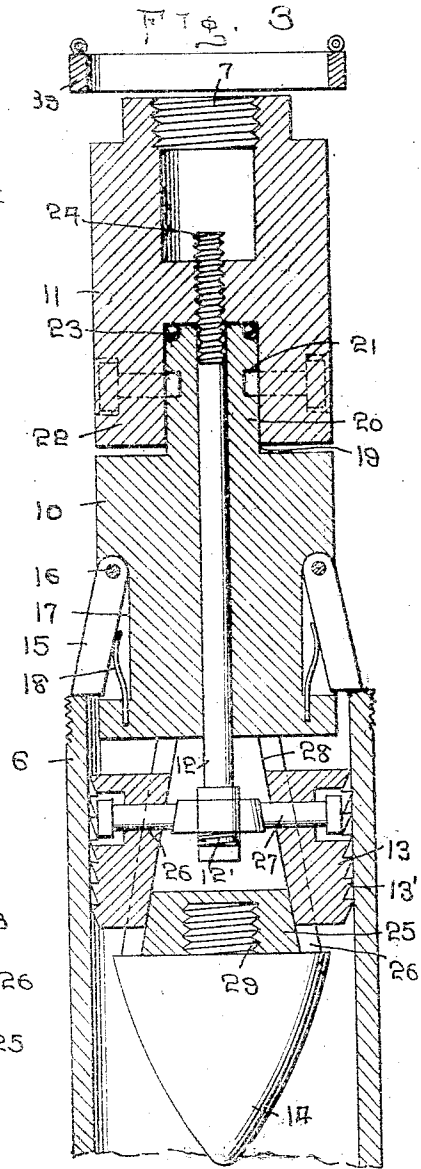
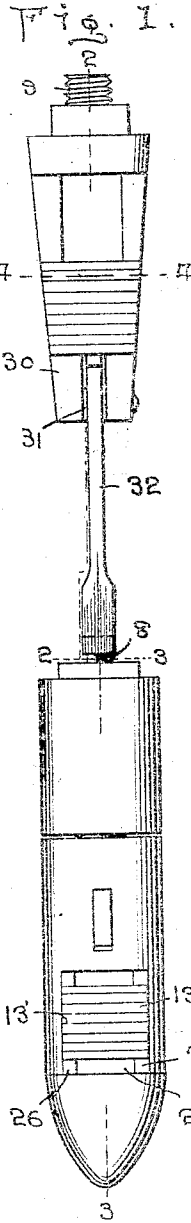
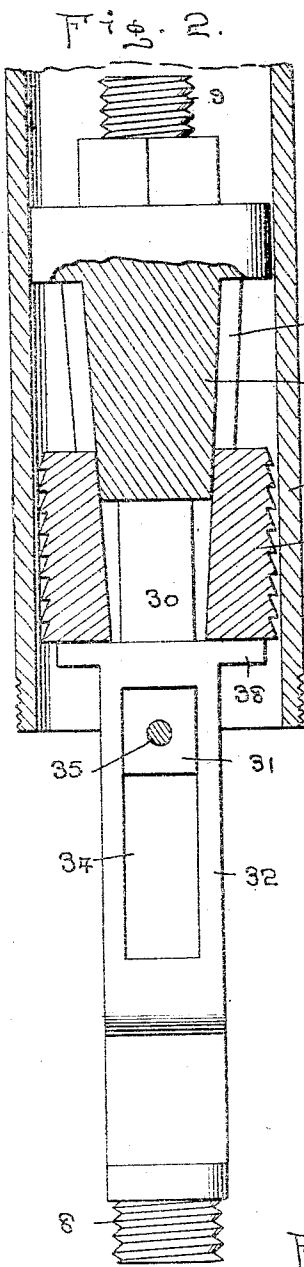

Witnesses
 Thos. W. Riley
 M. Newcomb

Inventor
 S. R. McCONNELL

W. J. FitzGerald & Co.
 Attorneys

UNITED STATES PATENT OFFICE.

SCOTT R. McCONNELL, OF WICHITA FALLS, TEXAS.

INTERNAL PIPE-GRIPPER.

1,069,560.

Specification of Letters Patent.

Patented Aug. 5, 1913.

Application filed January 23, 1913. Serial No. 743,203.

To all whom it may concern:

Be it known that I, SCOTT R. McCONNELL, a citizen of the United States, residing at Wichita Falls, in the county of Wichita and State of Texas, have invented certain new and useful Improvements in Internal Pipe-Grippers; and I do hereby declare the following to be a full, clear, and exact description of the invention, such as will enable others skilled in the art to which it appertains to make and use the same.

This invention relates to internal pipe grippers, and it more particularly relates to an improved tool for removing pipes or casings from drilled wells.

An object of the invention is to provide an improved form of gripping spear, whereby a well casing may be securely held and withdrawn from a well.

Another object of the invention is to provide a gripping tool of this character, by means of which one section of pipe may be employed for raising another section of pipe which has become detached.

Another object of the invention is to provide a gripping device of this character which is easily disengaged from the pipe in the event that it is found impossible or extremely difficult to remove said pipe.

Other objects and advantages may be recited hereinafter and in the claims.

In the accompanying drawings, which supplement the following specification, Figure 1 is an elevation view of my improved gripping tool. Fig. 2 is a fragmentary sectional view of a well casing, and showing on an enlarged scale, a section through the upper portion of the gripping tool as seen on the line 2-2 of Fig. 1. Fig. 3 is a fragmentary sectional view of a well casing, and showing on the same scale, a section through another portion of the gripping tool as seen on the line 3-3 of Fig. 1. Fig. 4 is a sectional view on the line 4-4 of Fig. 1.

In these drawings, in which similar reference characters designate corresponding parts throughout the several views, the numeral 5 designates the lower end of a section of pipe or well casing, and the numeral 6 designates the upper end of a similar well casing, for the purpose of illustrating my invention.

This invention comprises an upper section, as shown in Fig. 2, and a lower section, as shown in Fig. 3; the lower section being internally threaded at 7, and the lower end of the upper section being externally screw-threaded at 8, and adapted to engage with the threaded portion 7, as shown in Fig. 1. The upper section may be provided with any proper means for securing it to a suspending or lifting connection (not shown), said means being indicated by the screw-threads 9. The lower section consists of a spear element 10, a swivel 11, a draw rod 12, jaws 13, a spear head 14, and spring-pressed stop elements 15, the latter being pivoted at 16, and seated in apertures 17 of the spear element, and adapted to be depressed within the apertures 17, against the action of the springs 18. The spear element is centrally apertured throughout its upper portion, for the reception of the draw rod 12, this rod having its upper end in screw-threaded engagement with the nut or swivel element 11. The lower end of the swivel element is centrally apertured at 19, for the reception of a boss 20, formed on the upper end of the spear element, said boss being provided with a peripheral groove 21, for the reception of retaining screws 22, which are secured in the swivel element and extend into said peripheral groove, so that the swivel element may be rotated around said boss, but held against longitudinal movement thereon. Ball bearings 23 may be provided for decreasing the friction between the swivel element and the spear element; and, in order to further decrease the friction and reduce it to a minimum, I provide an oil chamber 24 in the upper portion of the swivel element. It is obvious that oil from the chamber 24 will be fed, by gravity and by capillary attraction between the screw-threads of the swivel element and the draw rod 12, so as to lubricate the ball bearings 23, the peripheral groove and the convexed surface of the boss 20.

The lower portion of the spear element 10 is provided with jaw-seating elements 25, formed with parallel shoulders 26, between which are seated the jaws 13, said jaws being provided with upwardly inclined and sharp teeth, and being apertured at 26 for the reception of studs 27; said studs being formed

or secured on the lower end of the draw rod 12. Between the shoulders 26 are the jaw-seats 28, which are upwardly inclined toward the axis of the swivel member, so that the jaw-seating element is wedge shaped, and converging upwardly. This jaw-seating element is provided with a relatively large aperture, communicating with the aperture which receives the draw rod 12, and in this relatively large aperture, the lower end of the rod 12 and the studs 27 have considerable room to move up and down, so that the jaws 13 may be caused thereby to travel on the jaw-seats 28, while the studs 27 have longitudinal movement in the apertures 26. The spear head may be of ordinary construction, and secured in any proper way, as for instance, by screw-threaded engagement with the element 25, as indicated at 29.

When a casing has been inserted in a well, having been driven or packed therein, it is usually held very tightly, by means of the surrounding earth and rocks, and therefore, it becomes necessary to jar and jerk the pipe, for the purpose of disengaging it. Therefore, it is necessary to provide the jar elements 30, 31 and 32. The jar element 30 consists of the bifurcated extension of the jaw-seating element 33, while the element 32 extends between the furcations 30, and is provided with a rectangular and elongated vertical aperture 34, in which is slidably seated the element 31, the latter being secured between the ends of the furcations 30, as indicated by the bolt 35, which may either constitute a pivotal or a rigid securing means, as desired. The element 33 is provided with dove-tail jaw seats 36, in which are slidably seated the jaws 37, which have downwardly inclined sharp teeth 37'.

It will be seen that if the element 32 is held stationary while the element 35 is moved downward, the block 31 will move downward in the slot 34, while the downwardly converging element 33 will have relative movement to the jaws 37, thereby separating the jaws: said jaws being supported by lateral extensions 38, which are formed or secured on the upper end of the element 32, and constitute jaw-actuating elements.

During the operation of drilling a well, the drilling tool is often deflected by contact with a boulder or slanting ledge, which causes the well to be out of vertical alignment, and therefore, when the casing is inserted, it is likely to become disconnected at one or more of the joints, owing to its contact with said boulder or ledge, and the necessary bending of the casing in conforming to the shape of the well. Moreover, it frequently occurs that after a well has been drilled to a very considerable depth, the expected result in obtaining water or oil is not attained, and therefore, the casing must either be extracted from the well or lost.

In attempting to remove the casing in sections, it sometimes occurs that dirt and stones will be dislodged from the side of the well, and will cover the casing which remains in the well, so that it is impossible to grapple or grip the remaining casing for removing it. It is contemplated by the present invention, to overcome the foregoing difficulties, in the following manner: When it is desired to remove a well casing, the spear and swivel elements shown in Fig. 3 are employed for raising the top section of pipe sufficiently to be grasped by a pipe jack (not shown), whereupon the rests 15 are depressed, so that the spear and swivel element may be lowered through the pipe. If the pipe is separated at any place, the upper section having been previously lifted, there will exist a space between the upper and lower sections, so that the rests 15, after passing through the upper section, will be forced outward into the position shown in Fig. 3; so that, when the spear element has been lowered sufficiently, it will be arrested by contact of said rests with the top of the lower section (see Fig. 3). At this stage of the operation, it is desired to grasp this lower section and lift it slightly, for the purpose of ascertaining whether the pipe is disconnected at any other place therebelow, and after thus raising this section, a ring 39 may be lowered into position around the spear element, so as to depress the rests 15, when the spear is slightly raised, so that the spear may then descend through this lower casing section, leaving the ring on top of said casing section. When the spear has been sufficiently lowered, it will again rest upon the upper end of a pipe section which has been disconnected, and the last said pipe section may be slightly raised, for the purpose of locating other disconnected places in the casing. In gripping the pipe sections, for the purpose of raising them, the swivel element 11 is rotated, through the medium of its suspending element, in contra-clockwise direction, so as to force the draw rod 12 downward, and thereby force the jaws downward on the wedge shaped jaw-seating element, so as to separate the jaws and force them into engagement with the inner surface of the pipe section, thus giving the jaw teeth 13' an initiatory hold or bite in the casing. The spear is now raised, and the weight of the casing draws the jaws farther down upon the wedge shaped portion 25, against the action of the spring 12', thereby further separating the jaws and causing the teeth 13' to bite deeper into the casing.

When it is desired to free the spear from the casing, the swivel element is rotated in clockwise direction, thereby raising the jaws relative to the wedge shaped portion 25 and directing their teeth out of engagement

with the casing. Now, assuming that the pipe casing is to be extracted, and has had its several sections separated, as described in the foregoing; the upper and lower sections of my improved gripping tool are secured together, as shown in Fig. 1. The tool is now lowered through the casing until the rests 15 are seated on the lower section 6, whereupon the jaws 13 are brought into gripping engagement, as described, and then the jaw seating element 33 is allowed to descend until it has forced the jaws 37 into gripping engagement with the upper pipe section. The sustaining element may then be disengaged from the screw-threads 9, or disconnected at its upper end and allowed to fall into the casing, whereupon, the said pipe jack, or other proper means may be set into operation for raising the upper section of casing, so that the jaws 37 are forced into more positive gripping contact with the upper section of casing, and the gripping tool now constitutes a coupling or connection between the upper and lower sections of casing. As the casing is raised, it may be disjointed and removed from the sections which are being raised, until the gripping tool has been drawn sufficiently above the surface of the ground to allow the lower section to be engaged by the pipe jack, whereupon the tool may be removed, as described.

Obviously, if the casing is found to be disconnected in several places, one of my improved gripping tools may be employed for each disconnected portion; the lower gripping tool being seated into gripping contact, and then the next lower, and so on until all of the sections have been connected, as described.

It will be seen that I have provided a device of this character which is fully capable of attaining the foregoing objects, and in a thoroughly practical and efficient manner.

I do not limit my invention to the exact details of construction and combination and arrangement of parts, as herewith illustrated and described, but my invention may only be limited by a reasonable interpretation of the following claims.

I claim:—

1. In a pipe gripping tool, a spear element having an upwardly inclined jaw-seating element, toothed and apertured jaws slidably seated for vertical movement on said jaw-seating element, studs slidably seated in the apertures of the jaws; a draw rod engaged with the studs and extending upwardly through a central aperture of the spear element, a swivel element mounted for rotary movement on the spear element, means for holding the swivel element against longitudinal movement relative to the spear element, and depressible support-

ing elements carried by the spear element, said draw rod being in screw-threaded engagement with the swivel element for moving the studs and thereby moving the jaws upon the upwardly inclined jaw-seating element for forcing the jaws into engagement with a pipe or casing, substantially as described.

2. In a pipe gripping and raising tool, a spear element having a vertical aperture therethrough and having recesses in its outer surface, said spear element including an upwardly inclined jaw-seating element, jaws having upwardly directed teeth mounted for vertical movement on the upwardly inclined jaw-seating portion, a draw rod extending through the vertical aperture of the spear element, means cooperating with the draw rod for moving the jaws upon the inclined jaw-seating element, rests seated in the recesses of the spear element and adapted to extend from the recesses into contact with the upper end of a pipe or casing, and a swivel element in screw-threaded engagement with said draw rod and adapted to move said draw rod longitudinally through the spear element.

3. In a tool of the character described, a spear element having gripping means associated therewith, said spear element having a vertical aperture therethrough, a draw rod extending through the vertical aperture and engaging the gripping means for operating the latter, a swivel element in screw-threaded engagement with the draw rod, and an oil chamber in the upper part of the swivel element, said draw rod extending into said oil chamber, so that oil may be fed by gravity and capillary attraction around the screw-threaded end of the rod, for thoroughly lubricating the swivel element.

4. In a device of the character described, a spear element having a vertical aperture and having a boss through which the vertical aperture extends, pipe gripping means associated with the spear element, a draw rod connected with the pipe gripping means for operating the latter, said draw rod having its upper end screw-threaded, a swivel element having an aperture into which the boss of the spear element is rotatably seated, said swivel element having a screw-threaded aperture in engagement with the threaded end of the draw rod, said swivel element being provided with an oil chamber in communication with the screw-threaded aperture, so that oil may be fed by capillary attraction and gravity around the threaded end of the draw rod and thereby lubricate the rod and the boss.

5. In a gripping tool for raising well casings, a spear element having gripping jaws seated thereon and having means associated therewith for moving the gripping jaws

into gripping contact with a pipe casing,
 depressible rests for contact with the top
 end of a casing section and holding the
 spear during the operation of gripping, and
 means for depressing the rests while the
 spear is within the well.
 In testimony whereof I have signed my

name to this specification in the presence of
 two subscribing witnesses.

SCOTT R. McCONNELL.

Witnesses:
 E. P. WALSH,
 B. M. TAYLOR.