

(No Model.)

J. C. HURLEY.  
CAR COUPLING.

No. 525,549.

Patented Sept. 4, 1894.

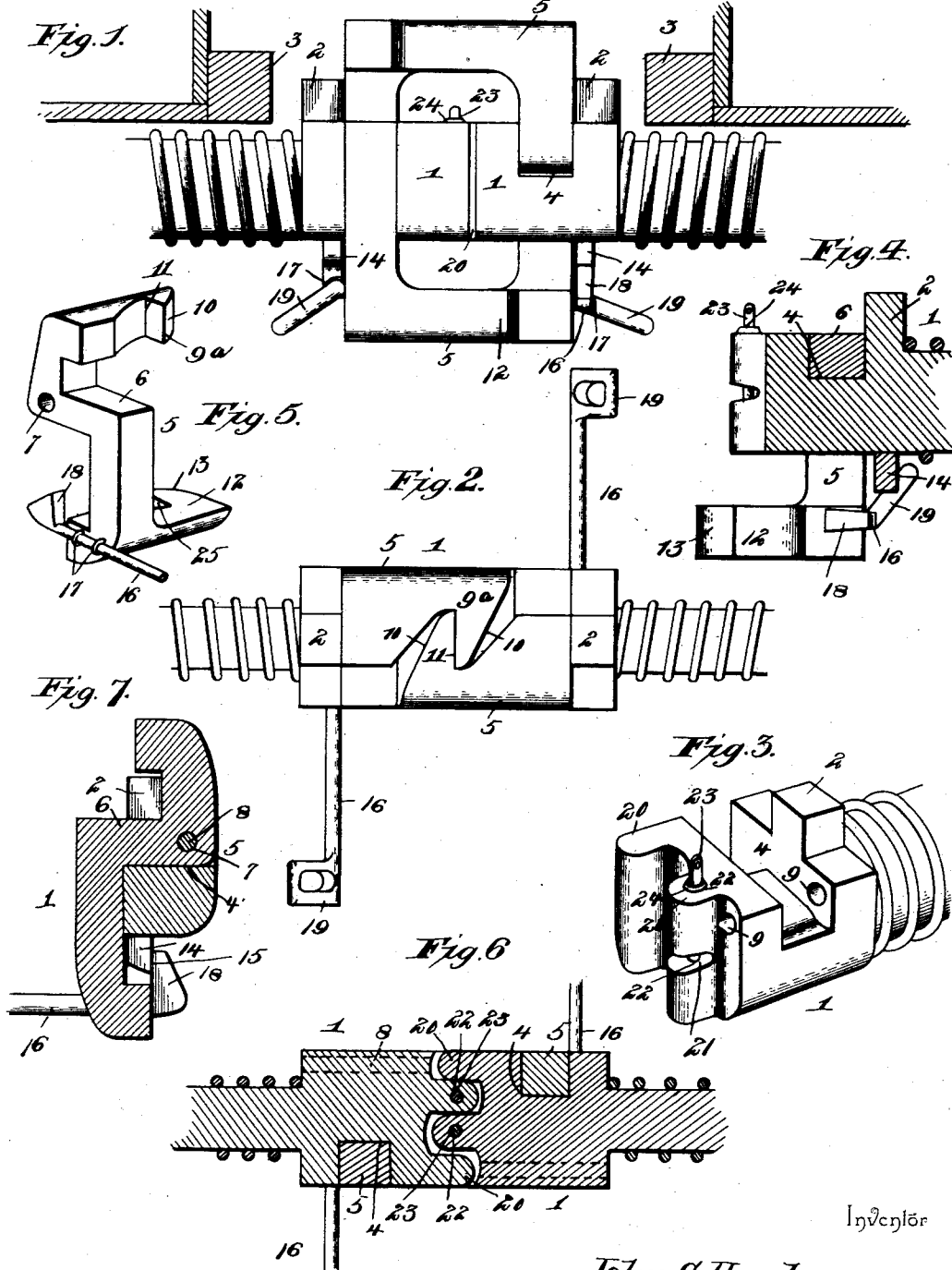

Witnesses  
*John C. Shaw.*  
*J. D. Quinn.*

By *John C. Hurley,*  
Attorneys.

*C. Snow & Co.*

Inventor

# UNITED STATES PATENT OFFICE.

JOHN C. HURLEY, OF FAIRHAVEN, WASHINGTON.

## CAR-COUPLING.

SPECIFICATION forming part of Letters Patent No. 525,549, dated September 4, 1894.

Application filed April 18, 1894. Serial No. 508,008. (No model.)

*To all whom it may concern:*

Be it known that I, JOHN C. HURLEY, a citizen of the United States, residing at Fairhaven, in the county of Whatcom and State of Washington, have invented a new and useful Car-Coupling, of which the following is a specification.

The invention relates to improvements in car couplings.

The object of the present invention is to simplify and improve the construction of car couplings, and to provide an efficient one capable of coupling automatically, and of being readily uncoupled without going between cars.

The invention consists in the construction and novel combination and arrangement of parts hereinafter fully described, illustrated in the accompanying drawings, and pointed out in the claims hereto appended.

In the drawings: Figure 1 is a side elevation of two car couplings constructed in accordance with this invention, and shown coupled. Fig. 2 is a plan view of the same. Fig. 3 is a detail perspective view of one of the draw-heads. Fig. 4 is a longitudinal sectional view of the car coupling. Fig. 5 is a detail perspective view of one of the jaws. Fig. 6 is a horizontal sectional view, the parts being arranged as shown in Fig. 1. Fig. 7 is a transverse sectional view, taken through one of the jaws.

Like numerals of reference indicate corresponding parts in all the figures of the drawings.

1 designates a draw-head mounted on a car 3, and provided with a cushioning spring, and having a shoulder 2 arranged in advance of the dead-wood of the car. The draw-head is provided with a transverse recess or groove 4, extending horizontally on the upper face of the draw-head and vertically at one side thereof, and receiving a pivoted jaw 5, which is composed of an angular shank 6 and upper and lower laterally offset hooks, arranged to engage similar hooks of a corresponding car coupling. The angular shank consists of a horizontal portion located in the recess 4, and extending transversely of the top of the draw-head, and vertically disposed arms extending upward and downward from the ends of the horizontal portion of the shank, and carrying

the hooks. The depending vertical arm of the shank 6 is located in the vertical portion of the recess 4, and the other arm of the shank extends vertically from the top of the draw-head in advance of the shoulder 2, and at the adjacent terminal of the recess 4. The shank 6 is provided at its angle, adjacent to the lower end of the upper arm, with a perforation 7, through which passes a pivot or pintle 8, which is also received in perforations 9 of the draw-head, located at the upper terminal of the L-shaped recess 4.

The upper laterally offset hook 9<sup>a</sup> has its front face 10 beveled, and is provided with a shoulder 11; and the lower laterally offset hook 12 has a correspondingly beveled front face 13, and is provided with a shoulder 25. These hooks extend horizontally from the terminals of the angular shank, and are adapted to be engaged by corresponding hooks; and when two cars come together for coupling, the beveled faces of the hooks contact, and the latter are forced laterally, the jaws swinging on the pintles 9, to permit the shoulders of the hooks to engage one another. The depending arm of the angular shank is longer than the upward extending arm, and the lower hook 12 may be slightly heavier than the upper one, and by these means the jaw 5 is maintained normally in proper position for automatic coupling.

The draw-head is provided in rear of the jaw 5 with a depending detent 14, which may be constructed integral with the draw-head, or otherwise as desired. The outer face of the detent is beveled, and its inner face forms a shoulder or stop, which is engaged by a hook or catch 18 of a rod or shaft 16 journaled in suitable bearings 17 at the back of the lower hook 12. The hook or catch 18 is arranged at the inner end of a rod or shaft 16, which is provided at its outer end with a handle 19, and which, after the jaw has engaged the hooks of a corresponding jaw for coupling, is adapted to be partially rotated to carry the catch 18 into engagement with the shoulder or stop of the detent, whereby the jaw is securely locked rigid with the draw-head, and its hooks are retained against lateral swing.

The operation of uncoupling may be performed from either side of a car by turning

the rod or shaft 16 to disengage the catch or hook 18 from the draw-head; the rods or shafts of two draw-heads project from opposite sides of the same, and either may be turned in the manner aforesaid, after which the operation of uncoupling may be completed by swinging the hooks of one jaw laterally out of engagement with the other jaw. The catch 18 and the rod 16 also contribute weight to the lower hook 12, to form a gravity catch of the pivoted jaw 5.

The draw-head is provided at its front end with vertical ribs or flanges 20, one of which is provided at its center with a horizontal recess 21, and has a vertical coupling pin perforation 22 receiving a coupling pin 23, which is provided with a head 24, and which is adapted to engage the ordinary construction of link to enable the draw-head to be coupled with those cars having the ordinary pin and link car couplings.

It will be seen that the car coupling is simple and inexpensive in construction and positive and reliable in operation, that it is capable of effecting the operation of coupling automatically, and that the operation of uncoupling may be readily performed without going between cars.

Changes in the form, proportion, and the minor details of construction may be resorted to without departing from the principle or sacrificing any of the advantages of this invention.

What I claim is—

1. In a car coupling, the combination of a draw-head, and a jaw pivotally mounted on the draw-head and disposed transversely thereof, and comprising an angular shank having a horizontal portion extending across the top of the draw-head and provided with vertical arms one of which extends upward from one end of the horizontal portion and the other depending from the opposite end of the horizontal portion at the adjacent side of the draw-head, and forwardly extending hooks arranged above and below the draw-head and projecting from the arms of the shank, substantially as described.

2. In a car coupling, the combination of a draw-head, and a jaw pivotally mounted on the draw-head at one side thereof and com-

prising a shank extending across the top and one side of the draw-head, and the hooks located above and below the draw-head and carried by the shank, substantially as described.

3. In a car coupling, the combination of a draw-head provided with a transverse recess extending across the top and one side of it, and a jaw having a horizontal and a vertical portion arranged in the recess of the draw-head and pivoted thereon, said jaw being provided with upper and lower hooks disposed opposite each other and located above and below the draw-head at the top and bottom of the jaw, substantially as described.

4. In a car coupling, the combination of a draw-head provided with a recess, a jaw pivoted in the recess and capable of swinging therein, and a hook revolubly mounted on the jaw and arranged to engage the draw-head and capable of being turned out of such engagement, whereby the jaw may be held against swinging and be released for uncoupling, substantially as described.

5. In a car coupling, the combination of a draw-head provided with a recess extending across the top and one side of it, a jaw having a horizontal and a vertical portion and arranged in the recess and pivoted therein at one end of the horizontal portion, coupling hooks carried by the jaw, and a securing hook journaled on the jaw and arranged to engage and disengage the draw-head, substantially as described.

6. In a car coupling, the combination of a draw-head provided with a stop, a jaw pivotally mounted on the draw-head and extending across the top and one side of the same and provided with upper and lower hooks, and an operating rod journaled on the jaw and carrying a catch arranged to engage the stop of the draw-head, and adapted to be carried out of such engagement by turning the rod, substantially as described.

In testimony that I claim the foregoing as my own I have hereto affixed my signature in the presence of two witnesses.

JOHN C. HURLEY,

Witnesses:

AGGIE MCNEIL,  
GEO. H. WATROUS.