

(19) World Intellectual Property Organization
International Bureau



(43) International Publication Date
20 August 2009 (20.08.2009)

(10) International Publication Number
WO 2009/102477 A1

(51) International Patent Classification:
H04N 7/18 (2006.01)

VANMAN, Robert, V. [US/US]; 6803 Shoreview Drive,
McKinney, TX 75070 (US).

(21) International Application Number:
PCT/US2009/000930

(74) Agents: **ROBINSON, Ross, t.** et al.; Winstead PC, P.O.
Box 50784, Dallas, TX 75201 (US).

(22) International Filing Date:
13 February 2009 (13.02.2009)

(81) Designated States (*unless otherwise indicated, for every
kind of national protection available*): AE, AG, AL, AM,
AO, AT, AU, AZ, BA, BB, BG, BH, BR, BW, BY, BZ,
CA, CH, CN, CO, CR, CU, CZ, DE, DK, DM, DO, DZ,
EC, EE, EG, ES, FI, GB, GD, GE, GH, GM, GT, HN,
HR, HU, ID, IL, IN, IS, JP, KE, KG, KM, KN, KP, KR,
KZ, LA, LC, LK, LR, LS, LT, LU, LY, MA, MD, ME,
MG, MK, MN, MW, MX, MY, MZ, NA, NG, NI, NO,
NZ, OM, PG, PH, PL, PT, RO, RS, RU, SC, SD, SE, SG,
SK, SL, SM, ST, SV, SY, TJ, TM, TN, TR, TT, TZ, UA,
UG, US, UZ, VC, VN, ZA, ZM, ZW.

(25) Filing Language: English

(26) Publication Language: English

(30) Priority Data:
61/029,092 15 February 2008 (15.02.2008) US
61/029,101 15 February 2008 (15.02.2008) US

(71) Applicant (*for all designated States except US*): **EN-
FORCEMENT VIDEO, LLC** [US/US]; 3001 Summit
Avenue, Suite 400, Plano, TX 75074 (US).

(72) Inventors; and

(75) Inventors/Applicants (*for US only*): **CILIA, Andrew**
[US/US]; 8200 Ivy Lane, McKinney, TX 75071 (US).

(84) Designated States (*unless otherwise indicated, for every
kind of regional protection available*): ARIPO (BW, GH,
GM, KE, LS, MW, MZ, NA, SD, SL, SZ, TZ, UG, ZM,
ZW), Eurasian (AM, AZ, BY, KG, KZ, MD, RU, TJ,
TM), European (AT, BE, BG, CH, CY, CZ, DE, DK, EE,

[Continued on next page]

(54) Title: SYSTEM AND METHOD FOR HIGH-RESOLUTION STORAGE OF IMAGES

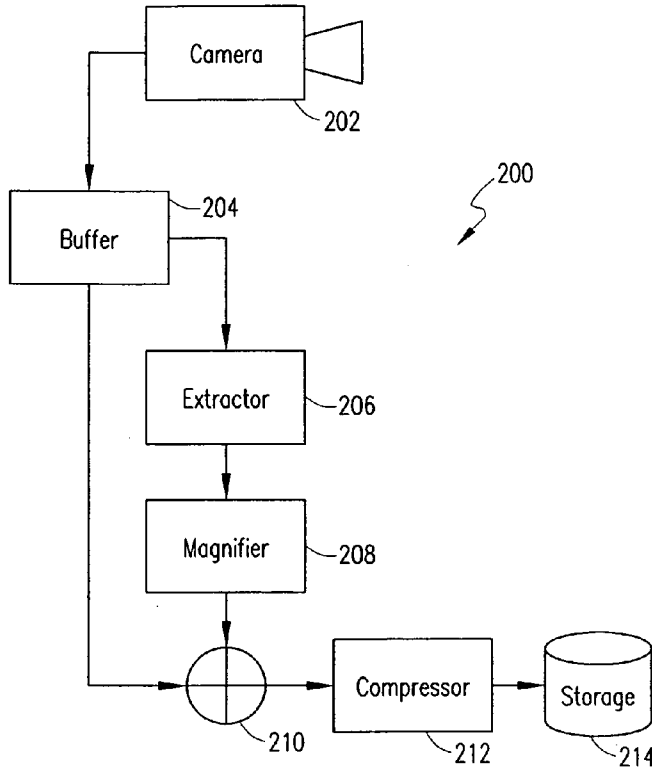

FIG. 2

(57) Abstract: An image-creation method includes capturing an image as digital data, locating an area of interest of the captured image, extracting, from the digital data, at least some data corresponding to the located area of interest, digitally magnifying the extracted at least some data to yield digitally magnified data, and combining the digitally magnified data with at least some of the digital data of the captured image to yield combined data.

WO 2009/102477 A1

ES, FI, FR, GB, GR, HR, HU, IE, IS, IT, LT, LU, LV, **Published:**
MC, MK, MT, NL, NO, PL, PT, RO, SE, SI, SK, TR), — *with international search report (Art. 21(3))*
OAPI (BF, BJ, CF, CG, CI, CM, GA, GN, GQ, GW, ML,
MR, NE, SN, TD, TG).

SYSTEM AND METHOD FOR HIGH-RESOLUTION STORAGE OF IMAGES

CROSS-REFERENCE TO RELATED APPLICATIONS

[001] This patent application claims priority from, and incorporates by reference for any purpose the entire disclosure of, U.S. Provisional Patent Application No. 61/029,101, filed February 15, 2008. In addition, this patent application claims priority from and incorporates by reference U.S. Provisional Patent Application No. 61/029,092, also filed February 15, 2008. This patent application also incorporates by reference U.S. Patent Application Publication No. 2006/0158968, filed on October 12, 2005, and a patent application filed on the same date as this patent application and bearing Docket No. 47565-P011US.

Technical Field

[002] This application relates generally to video surveillance and more particularly to systems and methods for high-resolution storage of images.

Background

[003] Many police cars now include a video camera to capture activities transpiring both outside and inside the vehicle. One use of the video captured by these cameras is as evidence in a criminal trial. In order for the videos to be used as evidence, the images must be clearly identifiable by, for example, a jury or an expert witness. Often police cars and their corresponding devices for recording video data may remain in use for extended periods of time, for example, when an officer stays out on patrol overnight. It is often necessary to compress the video being recorded in order to be able to store those large volumes of data.

[004] In order to store the large amount of data captured by the video camera over long periods of time, compression algorithms are normally used to compress the data. There are various compression algorithms currently in use for compressing videos, such as lossless and lossy algorithms. In a lossy algorithm, some visual quality is lost in the compression process and cannot be restored. The various compression algorithms utilize a combination of techniques for

compressing the data such as downsampling or subsampling, block splitting, pixilating, and lowering resolution. A few examples of compression algorithms include the MPEG family of algorithms such as MPEG 2 and MPEG 4.

SUMMARY OF THE INVENTION

[005] An image-creation method includes capturing an image as digital data, locating an area of interest of the captured image, extracting, from the digital data, at least some data corresponding to the located area of interest, digitally magnifying the extracted at least some data to yield digitally magnified data, and combining the digitally magnified data with at least some of the digital data of the captured image to yield combined data.

[006] An article of manufacture for image creation includes at least one computer readable medium, and processor instructions contained on the at least one computer readable medium. The processor instructions are configured to be readable from the at least one computer readable medium by at least one processor and thereby cause the at least one processor to operate to capture an image as digital data, locate an area of interest of the captured image, extract, from the digital data, at least some data corresponding to the located area of interest, digitally magnify the extracted at least some data to yield digitally magnified data, and combine the digitally magnified data with at least some of the digital data of the captured image to yield combined data.

BRIEF DESCRIPTION OF THE DRAWINGS

[007] A more complete understanding of various embodiments of the present invention may be obtained by reference to the following Detailed Description when taken in conjunction with the accompanying Drawings wherein:

[008] FIG. 1 is a flow chart of a process for compressing and storing data;

[009] FIG. 2 is a diagram of a system for capturing and storing video data;

[0010] FIG. 3 is an illustrative view of a video image with an insert in a corner of the image;

[0011] FIG. 4 is an illustrative view of a video image with a magnified area inserted into the image; and

[0012] FIG. 5 is an illustrative view of a video image with a fixed zoom box; and

DETAILED DESCRIPTION OF ILLUSTRATIVE EMBODIMENTS OF THE INVENTION

[0013] Various embodiments of the present invention contemplate identifying areas of importance in a video image that would be desirable to save in a high-resolution format. Some embodiments contemplate magnifying areas of interest before compressing video of the areas of interest so that deleterious effects of compression losses of some video data may be lessened. In that way, large volumes of data can be stored while minimizing the loss of clarity of the areas of interest. The above summary of the invention is not intended to represent each embodiment or every aspect of the present invention.

[0014] In some cameras, a data stream coming from the camera may contain both chroma (*i.e.*, color information) and luma (*i.e.*, brightness or black-and-white information). Most of the resolution may be contained in the black-and-white content of the video, even though the images may be color images. In some video streams, the resolution of the black and white pixels may be, for example, four times that of the color. Between the luma and chroma information, the luma may contain much of the information relative to how much detail is visible in a given image.

[0015] Clarity is often critical to police work, for example, to identify a particular vehicle or suspect to a jury. Therefore, it is important that recorded images remain clear even after video of the images has been compressed. For example, when video of a traffic stop is recorded, it is important that clarity of a license-plate portion of the video remains so that letters and numbers of the license plate are identifiable. However, almost all compression algorithms lower the clarity and sharpness of images being compressed, making things like facial features, letters, and numbers harder to identify. For example, some cameras may capture data at the equivalent of approximately 480 horizontal lines while the data may be stored at only, for example, 86 horizontal lines. The resolution of the recorded video may therefore be, for

example, one-fourth the resolution of the video the camera actually captured. By accessing video data while it is still at its captured resolution, effects of the compression algorithms and lower resolution settings on the readability of the license plates or other images can be minimized.

[0016] FIG. 1 is a flow chart showing a process 100 for automatic image magnification. The process 100 begins at step 102. At step 102, an image capture device, such as a camera, captures video images in a field of view of the camera. In some embodiments, the camera may be mounted in a police car and adapted to capture video while the police car is moving and also when the police car is stopped, for example, during a traffic stop.

[0017] From step 102, execution proceeds to step 104. At step 104, the captured video images are sent to a buffer. At step 106, areas of interest in the captured and buffered data are located. In some embodiments, raw data of the captured images may be read and an automatic license-plate locator algorithm run to identify, for example, whether one or more license plates are in the field of view. In some embodiments, only the luma information and not the chroma information may be viewed. The luma information may have more resolution than the chroma information. In some embodiments, a CPU may, for example, run a facial-feature location algorithm typically used, for example, to identify whether there are people in the field of view. In various embodiments, the license-plate location algorithm runs on raw data coming from the camera. It is also contemplated that the license-plate location algorithm may run on compressed data and a feedback signal may be sent as to the location of the pixels to be extracted from the uncompressed data.

[0018] Once the one or more areas of interest (*e.g.*, license plates or faces) have been located at step 108, the location information relative to each of the areas of interest is sent to an extractor. For example, the location information sent may be one or more sets of coordinates, such as, for example, coordinates corresponding to the four corners of a license plate. Information related to, for example, the size of the one or more license plates may also be sent. At step 109, the location information is used to extract data corresponding to the area of interest, (*e.g.*, the areas of license plates). At step 110, the extracted data may be altered so that pixels represented thereby are magnified relative to an original image to yield a magnified image. At

step 112, the data representing the magnified image is combined with at least some of the data captured by the video camera at step 102. The combined data, including the raw data and the magnified-image data, is compressed at step 114 to yield combined compressed data. At step 116, the combined compressed data is stored on a recordable medium such as, for example, a digital video disc (DVD).

[0019] Referring now to FIG. 2, a system 200 for magnifying areas of interest is shown. A camera 202 captures raw video data. The raw video data is sent by the camera 202 to a buffer 204. The camera 202 may be pointing through, for example, the windshield of a police car. Data corresponding to a zoom area (*e.g.*, a zoom box) subset of the raw video data from the camera is extracted from the buffer 204 by an extractor 206. The extracted data is digitally magnified by a magnifier 208, to yield a magnified zoom area. The digitally magnified zoom area is inserted into the raw data by a combiner 210 to yield a combined data output. The combined data is output by the combiner 210, compressed by a compressor 212, and stored onto a storage medium 214. Each of the buffer 204, the extractor 206, the magnifier 208, the combiner 210, the compressor 212, and the storage 214 may be hardware or software based.

[0020] Those having skill in the art will recognize that the embodiment shown in FIG. 2 does not necessarily require an automatic license-plate locator algorithm because, for example, the zoom area may be a fixed area on the field of view of the camera. To ensure the zoom area encompasses a license plate or other area of interest, in some embodiments an officer can point the camera in a particular direction so that the fixed zoom area captures the area of interest. For example, the officer may pull up behind a car and steer the police car so the zoom area captures the license plate of the car. Additionally, the officer may, for example, rotate the camera so that the zoom area encompasses the area of interest. In some embodiments, the zoom area may be moved within the field of view by a user interface, such as a touch screen or directional buttons, to change the area being magnified without needing to aim the camera's lens.

[0021] Referring now to FIG. 3, an image 300 is shown. The image 300 has a magnified insert 302. An area of interest has been highlighted by a zoom box 304 in the image 300. In some embodiments, an automatic license-plate locator algorithm may have been run to locate the license plate in the image 300. In some embodiments, a user may have moved the

zoom box 304 to position the zoom box 304 over an area of interest. In the embodiment shown, the magnified area 302 has been inserted on top of a different area of the image 300, for example in a bottom corner as a picture-in-picture (PIP) view.

[0022] In some embodiments, an indication of where the zoom box 304 was originally located before extraction is included in the stored data. For example, a thin colored line may encompass the license plate of the car whose license plate has been magnified. In some embodiments, multiple license plates in one field of view may be identified and rotated among by sequentially zooming the various license plates. As each license plate is in turn magnified, an indicator, for example, a thin red line, may, for example, encompass or highlight the license plate being magnified. In some embodiments, a plurality of different indicators, for example, different colored thin lines, may be used so that a plurality of license plates can be magnified at the same time with each different colored indicator showing the location of the magnified license plate relative to the original image.

[0023] Referring now to FIG. 4, another way of inserting an image into a field of view is shown. In an image 400, a zoom box 402 containing a magnified image has been inserted back into the image 400 in approximately the same position from which the original image was removed. In the embodiment shown, the magnified image overlaps onto a larger area than that which was originally removed. In some embodiments, the zoom box 402 may be limited to the original size of the part of the image 400 that was removed. For example, the magnified image 402 may be placed back over the part of the image 400 in which the original license plate was located. In various embodiments, the face of a driver or other information may be within the area of interest that is magnified, for example, by increasing the size of the image and inserting it back into the field of view on top of the original image.

[0024] Referring now to FIG. 5, a fixed region, for example a strip across the middle of a video image captured by a camera may be magnified and inserted along the bottom of a video to be stored. Oftentimes, the hood of the police car is in the field of view of the camera. Since video of the hood does not typically need to be recorded, it may be desirable to insert the magnified video image along the bottom of the field of view. Similarly, oftentimes the sky is recorded; in that case, it may be desirable to insert the strip of magnified video across the top of

the field of view where the sky is usually located. In other embodiments, a vertical strip may be magnified and inserted. In various embodiments, a user has the option of selecting the size and shape of the area being recorded and where the magnified images should be inserted. Those having skill in the art will appreciate that various embodiments may permit magnified still images to be recorded or magnified video to be recorded or both.

[0025] In some embodiments, the video output saved to the storage device may be at the same video quality and same compression level and take up approximately the same amount of storage space, but, due to magnification, the areas of interest are more readable. While the area of interest is typically readable without need for an optical zoom of the camera, in some embodiments, an optical zoom may be used to further enhance resolution of areas of interest. Similarly, some embodiments contemplate use of a digital zoom. In some embodiments, the process is different from a typical digital zoom because video may be accessed while the video is still in a raw form. In that way, a high-resolution image may be extracted before the compression algorithm has been implemented and before reduced video quality settings have been applied.

[0026] Although various embodiments of the method and system of the present invention have been illustrated in the accompanying Drawings and described in the foregoing Detailed Description, it will be understood that the invention is not limited to the embodiments disclosed, but is capable of numerous rearrangements, modifications and substitutions without departing from the spirit of the invention as set forth herein.

What is claimed is:

1. An image-creation method comprising:
capturing an image as digital data;
locating an area of interest of the captured image;
extracting, from the digital data, at least some data corresponding to the located area of interest;
digitally magnifying the extracted at least some data to yield digitally magnified data; and
combining the digitally magnified data with at least some of the digital data of the captured image to yield combined data.
2. The image-creation method of claim 1, further comprising buffering the digital data.
3. The image-creation method of claim 2, further comprising retrieving the captured data from the buffer.
4. The image-creation method of claim 1, wherein the locating step is performed before the capturing step.
5. The image-creation method of claim 1, further comprising identifying data corresponding to the located area of interest.
6. The image-creation method of claim 1, wherein the extracting step comprises extracting the data corresponding to the located area of interest.
7. The image-creation method of claim 1, wherein the extracting step comprises copying the at least some data corresponding to the located area of interest and not modifying the data corresponding to the located area of interest as present in the captured image.

8. The image-creation method of claim 1, further comprising compressing the combined data.

9. The image-creation method of claim 1, wherein the combining step results in an image corresponding to the digitally magnified data being located in an area of low interest of an image represented by the combined data.

10. The image-creation method of claim 1, further comprising identifying an area of low interest of the image.

11. The image-creation method of claim 10, wherein the combining step results in an image corresponding to the digitally magnified data being located in the area of low interest.

12. The image-creation method of claim 1, further comprising using the combined data to display a modified image.

13. The image-creation method of claim 1, further comprising:
repeating the recited steps a plurality of times; and
saving modified video data formed therefrom.

14. An article of manufacture for image creation, the article of manufacture comprising:
at least one computer readable medium;
processor instructions contained on the at least one computer readable medium, the processor instructions configured to be readable from the at least one computer readable medium by at least one processor and thereby cause the at least one processor to operate as to perform the following steps:
capturing an image as digital data;
locating an area of interest of the captured image;

extracting, from the digital data, at least some data corresponding to the located area of interest;
digitally magnifying the extracted at least some data to yield digitally magnified data; and
combining the digitally magnified data with at least some of the digital data of the captured image to yield combined data.

15. The article of manufacture of claim 14, wherein the processor instructions are configured to cause the at least one processor to operate as to perform the following step:
buffering the digital data.

16. The article of manufacture of claim 15, wherein the processor instructions are configured to cause the at least one processor to operate as to perform the following step:
retrieving the captured data from the buffer.

17. The article of manufacture of claim 14, wherein the locating step is performed before the capturing step.

18. The article of manufacture of claim 14, wherein the processor instructions are configured to cause the at least one processor to operate as to perform the following step:
identifying data corresponding to the located area of interest.

19. The article of manufacture of claim 14, wherein the extracting step comprises extracting the data corresponding to the located area of interest.

20. The article of manufacture of claim 14, wherein the extracting step comprises copying the at least some data corresponding to the located area of interest and not modifying the data corresponding to the located area of interest as present in the captured image.

21. The article of manufacture of claim 14, wherein the processor instructions are configured to cause the at least one processor to operate as to perform the following step:
compressing the combined data.

22. The article of manufacture of claim 14, wherein the combining step results in an image corresponding to the digitally magnified data being located in an area of low interest of an image represented by the combined data.

23. The article of manufacture of claim 14, further comprising identifying an area of low interest of the image.

24. The article of manufacture of claim 23, wherein the combining step results in an image corresponding to the digitally magnified data being located in the area of low interest.

25. The article of manufacture of claim 14, wherein the processor instructions are configured to cause the at least one processor to operate as to perform the following step:
using the combined data to display a modified image.

26. The article of manufacture of claim 14, wherein the processor instructions are configured to cause the at least one processor to operate as to perform the following steps:
repeating the recited steps a plurality of times; and
saving modified video data formed therefrom.

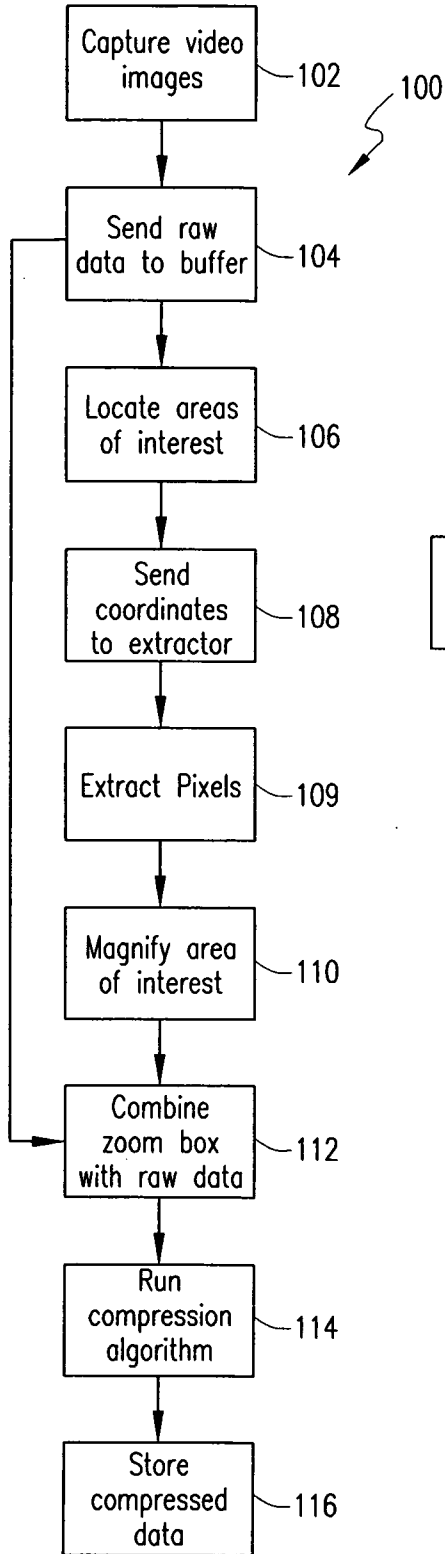

FIG. 1

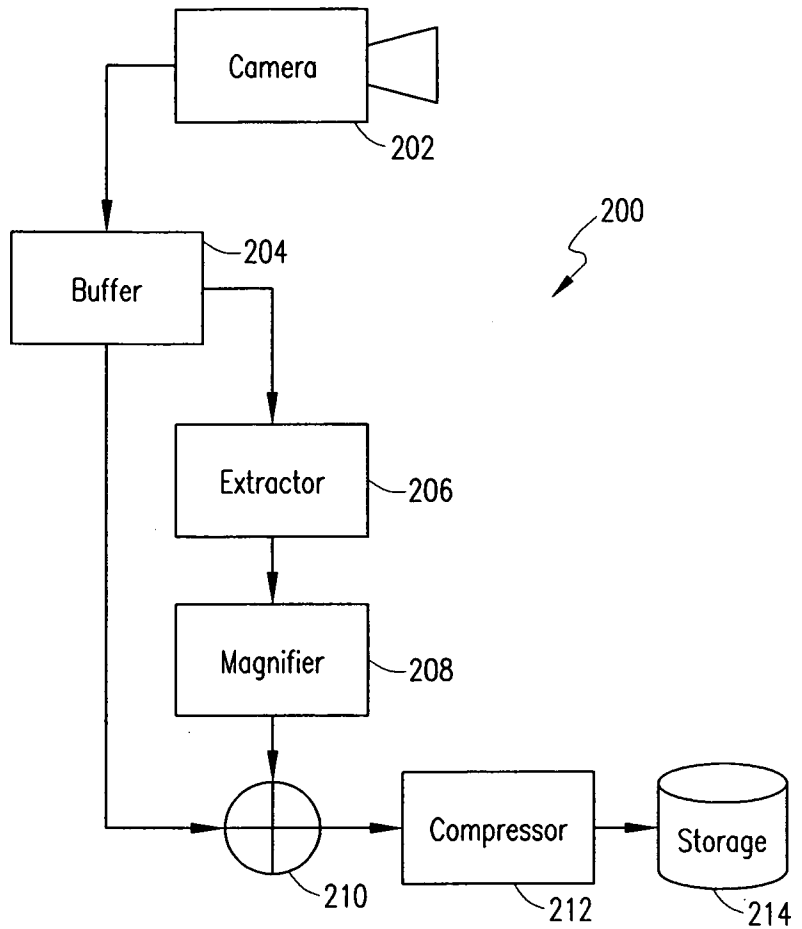

FIG. 2

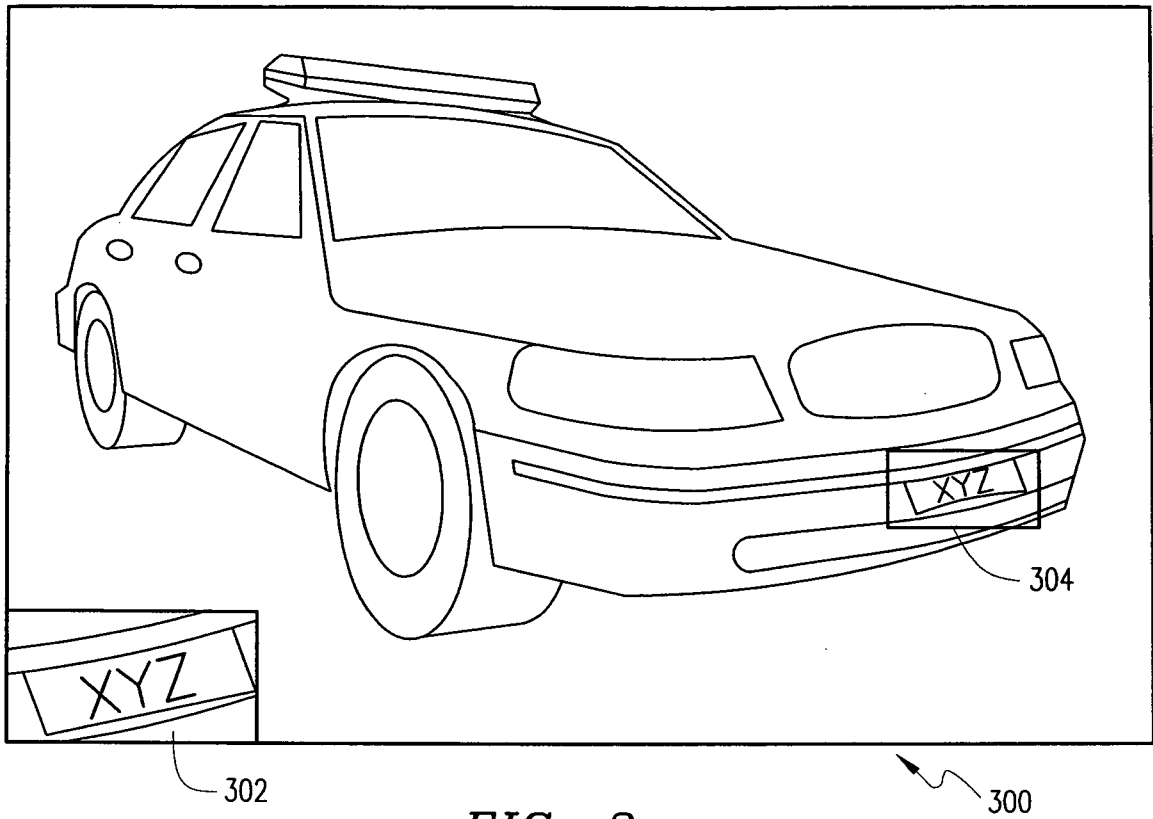

FIG. 3

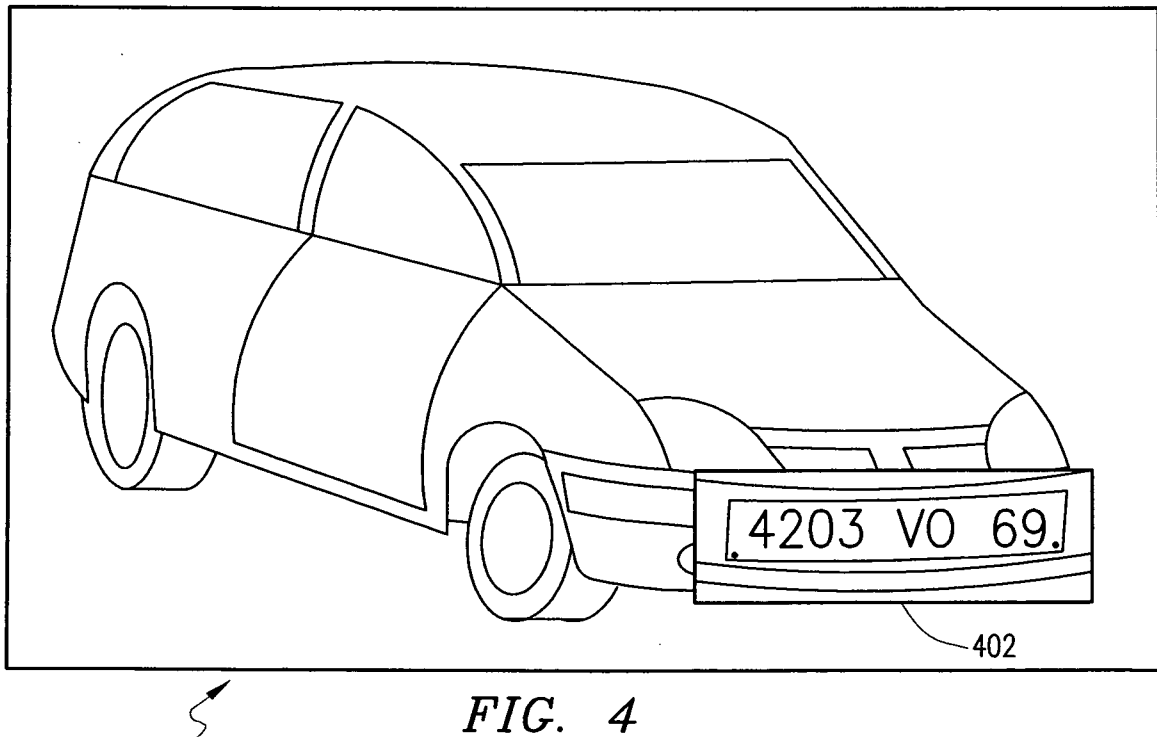

FIG. 4

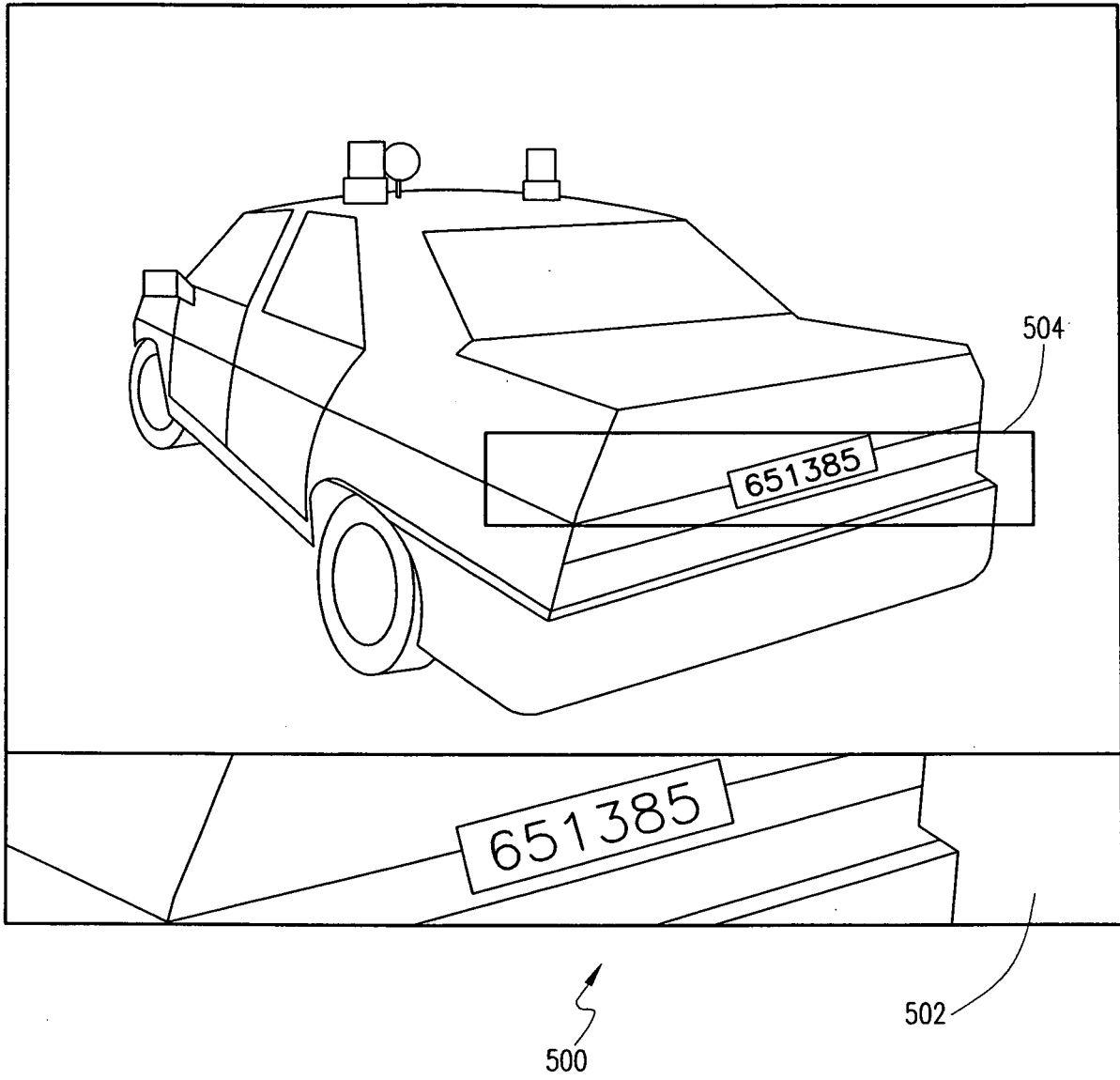

FIG. 5

INTERNATIONAL SEARCH REPORT

International application No.

PCT/US2009/000930

A. CLASSIFICATION OF SUBJECT MATTER IPC(8) - H04N7/18 (2009.01) USPC - 348/149 According to International Patent Classification (IPC) or to both national classification and IPC		
B. FIELDS SEARCHED		
Minimum documentation searched (classification system followed by classification symbols) IPC(8) - H04N7/18 (2009.01) USPC - 348/149		
Documentation searched other than minimum documentation to the extent that such documents are included in the fields searched		
Electronic data base consulted during the international search (name of data base and, where practicable, search terms used) PatBase, Google Patents		
C. DOCUMENTS CONSIDERED TO BE RELEVANT		
Category*	Citation of document, with indication, where appropriate, of the relevant passages	Relevant to claim No.
X	US 2004/0252193 A1 (HIGGINS) 16 December 2004 (16.12.2004) entire document	1-26
A	US 2002/0149476 A1 (OGURA) 17 October 2002 (17.10.2002) entire document	1-26
A	US 2003/0214585 A1 (BAKEWELL) 20 November 2003 (20.11.2003) entire document	1-26
<input type="checkbox"/> Further documents are listed in the continuation of Box C. <input type="checkbox"/>		
* Special categories of cited documents:	"T" later document published after the international filing date or priority date and not in conflict with the application but cited to understand the principle or theory underlying the invention	
"A" document defining the general state of the art which is not considered to be of particular relevance	"X" document of particular relevance; the claimed invention cannot be considered novel or cannot be considered to involve an inventive step when the document is taken alone	
"E" earlier application or patent but published on or after the international filing date	"Y" document of particular relevance; the claimed invention cannot be considered to involve an inventive step when the document is combined with one or more other such documents, such combination being obvious to a person skilled in the art	
"L" document which may throw doubts on priority claim(s) or which is cited to establish the publication date of another citation or other special reason (as specified)	"&" document member of the same patent family	
"O" document referring to an oral disclosure, use, exhibition or other means		
"P" document published prior to the international filing date but later than the priority date claimed		
Date of the actual completion of the international search 19 March 2009	Date of mailing of the international search report 09 APR 2009	
Name and mailing address of the ISA/US Mail Stop PCT, Attn: ISA/US, Commissioner for Patents P.O. Box 1450, Alexandria, Virginia 22313-1450 Facsimile No. 571-273-3201	Authorized officer: Blaine R. Copenheaver PCT Helpdesk: 571-272-4300 PCT OSP: 571-272-7774	