



(86) Date de dépôt PCT/PCT Filing Date: 2001/04/05
 (87) Date publication PCT/PCT Publication Date: 2001/10/18
 (45) Date de délivrance/Issue Date: 2009/08/18
 (85) Entrée phase nationale/National Entry: 2002/09/13
 (86) N° demande PCT/PCT Application No.: US 2001/011201
 (87) N° publication PCT/PCT Publication No.: 2001/076510
 (30) Priorité/Priority: 2000/04/06 (US09/549,413)

(51) Cl.Int./Int.Cl. *A61F 2/24* (2006.01)
 (72) Inventeur/Inventor:
 SCHRECK, STEFAN, US
 (73) Propriétaire/Owner:
 EDWARDS LIFESCIENCES CORPORATION, US
 (74) Agent: BCF LLP

(54) Titre : VALVULES CARDIAQUES MINIMALEMENT INVASIVES ET METHODES D'UTILISATION
 CORRESPONDANTES

(54) Title: MINIMALLY-INVASIVE HEART VALVES AND METHODS OF USE

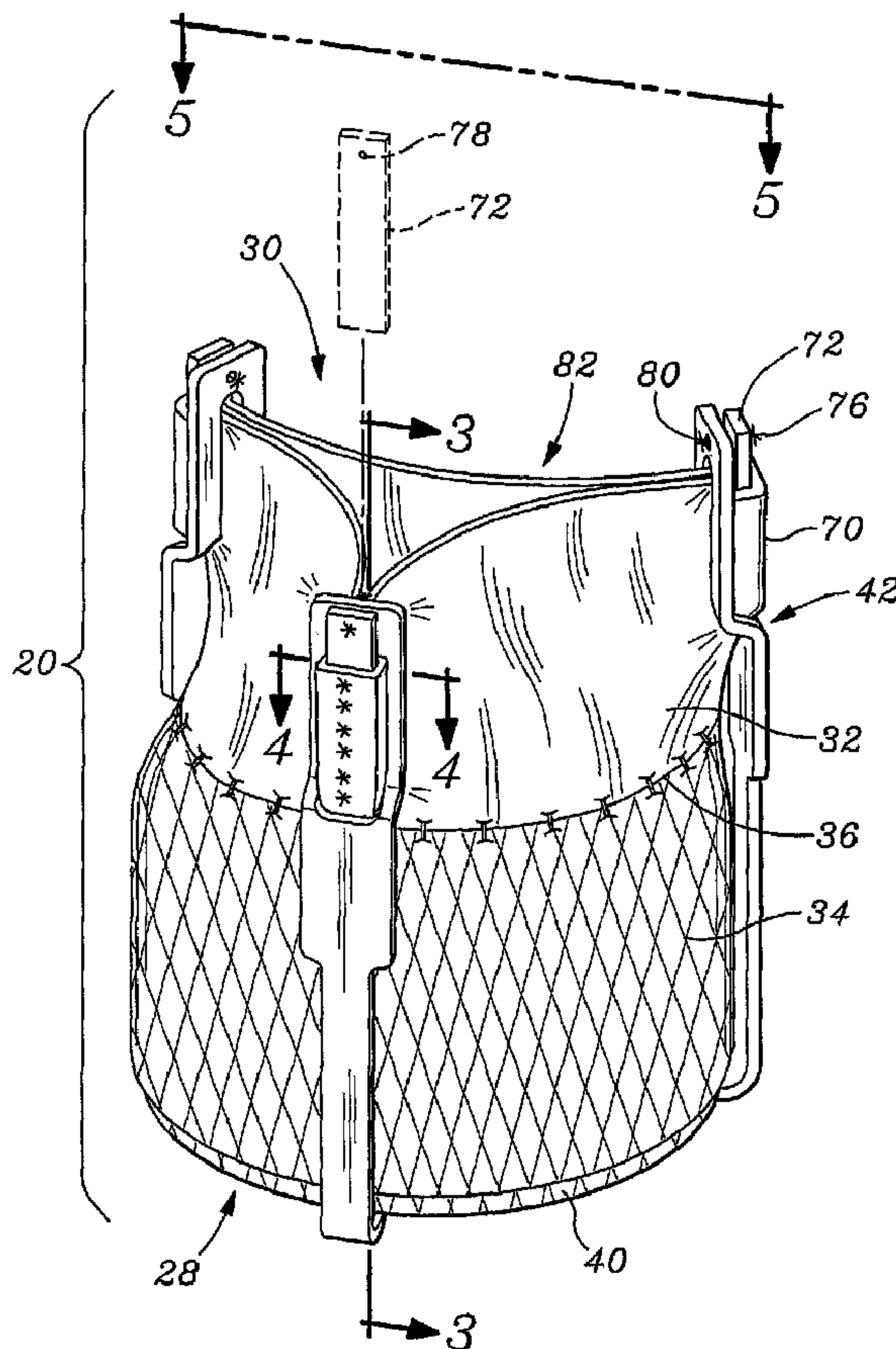

(57) Abrégé/Abstract:

Expandable heart valves for minimally invasive valve replacement surgeries are disclosed. In a first embodiment, an expandable pre-assembled heart valve includes a plastically-expandable annular base having plurality of upstanding commissure posts. A tubular

(57) **Abrégé(suite)/Abstract(continued):**

flexible member including a prosthetic section and a fabric section is provided, with the prosthetic section being connected to the commissure posts and defining leaflets therebetween, and the fabric section being attached to the annular base. In a second embodiment, an expandable heart valve includes an annular tissue-engaging base and a subassembly having an elastic wireform and a plurality of leaflets connected thereto. The annular base and subassembly are separately stored and connected just prior to delivery to the host annulus. Preferably, the leaflet subassembly is stored in its relaxed configuration to avoid deformation of the leaflets. The expandable heart valves may be implanted using a balloon catheter. Preferably, the leaflets of the heart valves are secured to the commissure regions of the expandable stents using a clamping arrangement to reduce stress.

(12) INTERNATIONAL APPLICATION PUBLISHED UNDER THE PATENT COOPERATION TREATY (PCT)

(19) World Intellectual Property Organization
International Bureau(43) International Publication Date
18 October 2001 (18.10.2001)

PCT

(10) International Publication Number
WO 01/76510 A3

- (51) International Patent Classification⁷: A61F 2/24
- (21) International Application Number: PCT/US01/11201
- (22) International Filing Date: 5 April 2001 (05.04.2001)
- (25) Filing Language: English
- (26) Publication Language: English
- (30) Priority Data:
09/549,413 6 April 2000 (06.04.2000) US
- (71) Applicant: EDWARDS LIFESCIENCES CORPORATION [US/US]; One Edwards Way, Irvine, CA 92625 (US).
- (72) Inventor: SCHRECK, Stefan; 2057 White Birch Drive, Vista, CA 92083 (US).
- (74) Agents: JAMES, John, Christopher et al.; Edwards Lifesciences LLC, One Edwards Way, Irvine, CA 92614 (US).
- (81) Designated States (*national*): AE, AG, AL, AM, AT, AU, AZ, BA, BB, BG, BR, BY, BZ, CA, CH, CN, CR, CU, CZ, DE, DK, DM, DZ, EE, ES, FI, GB, GD, GE, GH, GM, HR, HU, ID, IL, IN, IS, JP, KE, KG, KP, KR, KZ, LC, LK, LR, LS, LT, LU, LV, MA, MD, MG, MK, MN, MW, MX, MZ, NO, NZ, PL, PT, RO, RU, SD, SE, SG, SI, SK, SL, TJ, TM, TR, TT, TZ, UA, UG, UZ, VN, YU, ZA, ZW.
- (84) Designated States (*regional*): ARIPO patent (GH, GM, KE, LS, MW, MZ, SD, SL, SZ, TZ, UG, ZW), Eurasian patent (AM, AZ, BY, KG, KZ, MD, RU, TJ, TM), European patent (AT, BE, CH, CY, DE, DK, ES, FI, FR, GB, GR, IE, IT, LU, MC, NL, PT, SE, TR), OAPI patent (BF, BJ, CF, CG, CI, CM, GA, GN, GW, ML, MR, NE, SN, TD, TG).
- Published:
— with international search report

[Continued on next page]

(54) Title: MINIMALLY-INVASIVE HEART VALVES AND METHODS OF USE

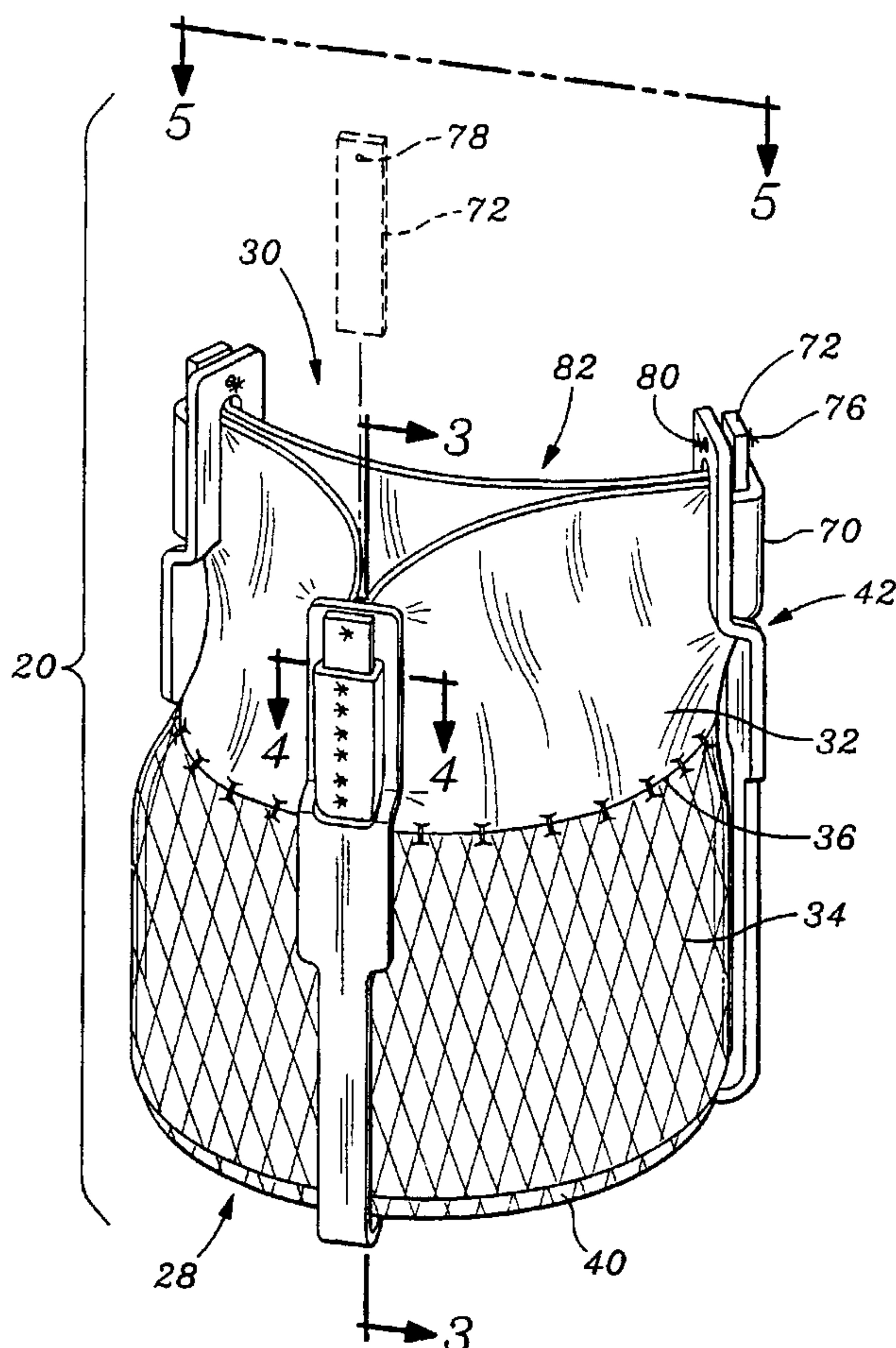

(57) Abstract: Expandable heart valves for minimally invasive valve replacement surgeries are disclosed. In a first embodiment, an expandable pre-assembled heart valve includes a plastically-expandable annular base having plurality of up-standing commissure posts. A tubular flexible member including a prosthetic section and a fabric section is provided, with the prosthetic section being connected to the commissure posts and defining leaflets therebetween, and the fabric section being attached to the annular base. In a second embodiment, an expandable heart valve includes an annular tissue-engaging base and a subassembly having an elastic wireform and a plurality of leaflets connected thereto. The annular base and subassembly are separately stored and connected just prior to delivery to the host annulus. Preferably, the leaflet subassembly is stored in its relaxed configuration to avoid deformation of the leaflets. The expandable heart valves may be implanted using a balloon catheter. Preferably, the leaflets of the heart valves are secured to the commissure regions of the expandable stents using a clamping arrangement to reduce stress.

WO 01/76510 A3

WO 01/76510 A3



— *before the expiration of the time limit for amending the claims and to be republished in the event of receipt of amendments*

Previous Correction:

see PCT Gazette No. 01/2002 of 3 January 2002, Section II

(88) Date of publication of the international search report:

4 April 2002

For two-letter codes and other abbreviations, refer to the "Guidance Notes on Codes and Abbreviations" appearing at the beginning of each regular issue of the PCT Gazette.

(15) Information about Correction:

MINIMALLY-INVASIVE HEART VALVES AND METHODS OF USE

Field of the Invention

The present invention relates generally to medical devices and particularly to
5 expandable heart valve prostheses especially for use in minimally-invasive surgeries.

Background of the Invention

Prosthetic heart valves are used to replace damaged or diseased heart valves. In
vertebrate animals, the heart is a hollow muscular organ having four pumping chambers:
10 the left and right atria and the left and right ventricles, each provided with its own one-
way valve. The natural heart valves are identified as the aortic, mitral (or bicuspid),
tricuspid and pulmonary valves. Prosthetic heart valves can be used to replace any of
these naturally occurring valves, although repair or replacement of the aortic or mitral
valves is most common because they reside in the left side of the heart where pressures
15 are the greatest.

Where replacement of a heart valve is indicated, the dysfunctional valve is
typically cut out and replaced with either a mechanical valve, or a tissue valve. Tissue
valves are often preferred over mechanical valves because they typically do not require
long-term treatment with anticoagulants. The most common tissue valves are
20 constructed with whole porcine (pig) valves, or with separate leaflets cut from bovine
(cow) pericardium. Although so-called stentless valves, comprising a section of porcine
aorta along with the valve, are available, the most widely used valves include some form
of stent or synthetic leaflet support. Typically, a wireform having alternating arcuate
cusps and upstanding commissures supports the leaflets within the valve, in combination
25 with an annular stent and a sewing ring. The alternating cusps and commissures mimic
the natural contour of leaflet attachment. Importantly, the wireform provides continuous
support for each leaflet along the cusp region so as to better simulate the natural support
structure.

A conventional heart valve replacement surgery involves accessing the heart in
30 the patient's thoracic cavity through a longitudinal incision in the chest. For example, a
median sternotomy requires cutting through the sternum and forcing the two opposing
halves of the rib cage to be spread apart, allowing access to the thoracic cavity and heart
within. The patient is then placed on cardiopulmonary bypass which involves stopping

the heart to permit access to the internal chambers. Such open heart surgery is particularly invasive and involves a lengthy and difficult recovery period.

Recently, a great amount of research has been done to reduce the trauma and risk associated with conventional open heart valve replacement surgery. In particular, the field of minimally invasive surgery (MIS) has exploded since the early to mid-1990s, with devices now being available to enable valve replacements without opening the chest cavity. MIS heart valve replacement surgery still requires bypass, but the excision of the native valve and implantation of the prosthetic valve are accomplished via elongated tubes or cannulas, with the help of endoscopes and other such visualization techniques.

Some examples of MIS heart valves are shown in U.S. Patent No. 5,980,570 to Simpson, U.S. Patent No. 5,984,959 to Robertson, et al., and PCT Publication No. WO 99/334142 to Vesely. Although these and other such devices provide various ways for collapsing, delivering, and then expanding a "heart valve" per se, none of them disclose an optimum structure for tissue valves. For instance, the publication to Vesely shows a tissue leaflet structure of the prior art in Fig. 1, and an expandable inner frame of the invention having stent posts in Figs. 3A-3C. The leaflets are "mounted to the stent posts in a manner similar to that shown in Figure 1." Such a general disclosure stops short of explaining how to construct an optimum valve. In particular, the means of attaching the leaflets to the MIS stent is critical to ensure the integrity and durability of the valve once implanted. All of the prior art MIS valves fall short in this regard.

In view of the foregoing, it is evident that an improved sewing ring that addresses the apparent deficiencies in existing expandable heart valves is necessary and desired.

Summary of the Invention

The present invention provides an expandable prosthetic heart valve for placement in a host heart valve annulus, comprising an expandable stent system adapted to be delivered in a collapsed state to an implantation site and expanded, and a plurality of prosthetic leaflets attached to the stent system. Each leaflet has an approximately semi-circular cusp edge terminating at each end in commissure portions, and a coapting edge extending between the commissure portions. Each leaflet is attached to the stent system substantially entirely along the cusp edge and at both commissure portions, with a coapting edge remaining unattached. The stent system may comprise an expandable

generally annular tissue-engaging base and an elastic generally annular wireform attached thereto. The base is adapted to be delivered in a radially collapsed state and expanded into contact with the host annulus. The annular wireform defines a plurality of upstanding commissures and a plurality of arcuate cusps between adjacent commissures, and the prosthetic leaflets are attached to the wireform along the cusps and commissures, wherein the wireform and leaflets are configured to be radially compressed.

In one embodiment, the heart valve includes a plurality of upstanding posts attached to one of the tissue-engaging base and elastic wireform, each post having a connector. A plurality of mating connectors are provided on the other of the tissue-engaging base and elastic wireform for mating with the post connectors. The posts and mating connectors may be provided for each commissure and each cusp of the elastic wireform so that the valve includes a number of posts and mating connectors equal to the number of commissures plus the number of cusps. Further, the expandable stent system may include an undulating wireform defining a plurality of commissures and a plurality of cusps between adjacent commissures. The cusp edge of each of the prosthetic leaflets attaches along a wireform cusp, and the commissure portions of each leaflet terminate in outwardly extending tabs that each attach to a wireform commissure, wherein tabs from adjacent leaflets are attached together at each of the wireform commissures.

In another aspect of the invention, an expandable prosthetic heart valve for placement in a host heart valve annulus is provided. The heart valve comprises an expandable stent portion and an elastic leaflet portion connectable to the stent portion. The stent portion defines an inflow end of the valve and is adapted to be delivered in a collapsed state and expanded into contact with the host annulus. The leaflet portion forms a one-way flow occluder on an outflow end of the valve and includes an elastic wireform defining alternating cusps and commissures and prosthetic tissue attached substantially entirely therealong. The stent portion desirably includes a tubular member and a plurality of connectors, and wherein a plurality of connectors are provided on the elastic wireform for mating with the tubular member connectors. The wireform connectors may be provided on each commissure and on each cusp of the wireform so that the valve includes a number of mating connectors equal to the number of commissures plus the number of cusps. In a preferred embodiment, the prosthetic tissue comprises a plurality of individual leaflets secured along the alternating cusps and

commissures of the elastic wireform. Additionally, the wireform may have a fabric covering, wherein the individual leaflets are stitched along the fabric covering. The fabric covering continues toward an inflow end of the valve in a skirt that surrounds the stent portion and is adapted to be captured between the expanded stent portion and the host annulus. A plurality of posts rigidly may connect to the stent portion and extend upward within the skirt into mating connection with the elastic wireform.

In a still further aspect, the present invention provides a two-part expandable prosthetic heart valve for placement in a host heart valve annulus, comprising:

a leaflet subassembly having a wireform defining a plurality of upstanding commissures and a plurality of arcuate cusps extending between adjacent commissures, a midpoint of each cusp being located approximately equidistant from the adjacent commissures;

a generally annular tissue-engaging base defining an axis; and

a system for connecting the leaflet subassembly and the tissue-engaging base, including a plurality of mating connectors on the leaflet subassembly and on the tissue-engaging base, wherein one connector each is provided at each commissure, and one at each cusp midpoint.

In the two-part heart valve, the tissue-engaging base preferably comprises an expandable tubular member that is deliverable to the host annulus in a collapsed state and expandable into contact with the host annulus to secure the valve therein. Furthermore, the tissue-engaging base forms an inflow end of the valve, and the system for connecting the leaflet subassembly and tissue-engaging base includes a plurality of posts coupled to the tubular member and having varying lengths extending away from the inflow end of the valve. A first plurality of posts each having a first length connects with the wireform commissures, and a second plurality of posts each having a second length connects with the wireform cusps shorter than the first length. The mating connectors may be configured to be joined together by axial compression, preferably with a snap-fit configuration.

A further aspect of the invention includes a prosthetic heart valve having a support stent and a flexible tubular member. The support stent includes a tubular base along an inflow end a plurality of generally axially-extending commissure posts disposed

evenly around the tubular base on an outflow end thereof. The flexible tubular member has a prosthetic section attached to the commissure posts so as to define a plurality of the prosthetic valve leaflets between the posts, and a fabric section connected to the base. The prosthetic section and fabric section are desirably both generally tubular and
5 attached together at a seam, wherein the seam is spaced from the outflow end of the tubular base so that only the fabric section of the flexible tubular member contacts the tubular base. The commissure posts each may have an axial slot, wherein the tubular member is primarily located within the posts except for a plurality of loops that extend outward through each slot on each post. A plurality of inserts sized larger than the slots
10 may be provided, each of which insert is captured within a loop extending outward through each slot to retain the loop through the slot. In a preferred embodiment, the commissure posts are integrally formed with the base, the base and commissure posts being initially formed from a flat section of material, wherein the commissure posts initially extend from the inflow end of the base and are bent 180° to extend alongside the
15 base and project beyond the base at the outflow end thereof.

A prosthetic heart valve of the present invention has a support stent including a tubular base along an inflow end. A plurality of generally axially-extending commissure posts each having an axial slot is disposed evenly around the tubular base on an outflow end thereof. A flexible tubular member having an outflow edge is primarily located
20 within the posts except for a plurality of loops that extend outward through each slot on each post. Further, a plurality of inserts sized larger than the slots are provided, each of which insert is captured within a loop extending outward through each slot to retain the loop through the slot, the outflow edge of the tubular member defining a plurality of valve leaflets. The tubular base may be plastically-expandable from a first size adapted
25 for minimally invasive delivery, to a second, functional size that fits within a heart valve annulus.

A method of minimally-invasive heart valve replacement surgery on a patient is also provided by the present invention. The method includes the steps of:

30 providing an annular tissue-engaging base, the base being expandable from a collapsed state;

providing a generally annular elastic wireform subassembly having a plurality of prosthetic leaflets connected thereto, the elastic wireform

subassembly having a relaxed, expanded size and a compressed, reduced size;
connecting the wireform and leaflets to the base to form a heart valve;
delivering the heart valve with the connected base in its collapsed state
and wireform subassembly in its reduced size to an annulus of the patient's heart
5 valve being replaced; and
expanding the base into its expanded state in contact with the annulus.

The step of delivering the heart valve to the annulus may be accomplished by
passing the valve through the patient's vasculature or via a minimally-invasive port in the
10 patient's chest. The tissue-engaging base may plastically-expandable from its collapsed
state to its expanded state, and the step of expanding the plastically-expandable base
comprises inflating a balloon within the annular base.

A further understanding of the nature and advantages of the invention will become
apparent by reference to the remaining portions of the specification and drawings.

15

Brief Description of the Drawings

Fig. 1 is an exploded perspective view of a first embodiment of an expandable
heart valve of the present invention, including a support stent and a flexible tubular
member;

20

Fig. 2 is an assembled perspective view of the expandable heart valve of Fig. 1;

Fig. 3 is a longitudinal cross-sectional view taken along line 3-3 through a
commissure of the expandable heart valve of Fig. 2;

Fig. 4 is a transverse cross-sectional view taken along line 4-4 through the
commissure of the expandable heart valve of Fig. 2;

25

Fig. 5 is a top plan view of the expandable heart valve of Fig. 2;

Fig. 6 is an exploded perspective view of a second embodiment of an expandable
heart valve of present invention having two detachable components designed to be
assembled post-storage, including a tissue-engaging base and a wireform-supported
leaflet subassembly;

30

Fig. 7 is an assembled perspective view of the expandable heart valve of Fig. 6,
with a fabric skirt removed to illustrate details of a connecting system between the base
and leaflet subassembly;

Fig. 8 is a plan view of an insert used to both attach individual leaflets to commissures of the wireform, and connect the commissures of the leaflet subassembly to the tissue-engaging base of the expandable heart valve of Fig. 6;

Fig. 9 is a plan view of an individual leaflet for use in the expandable heart valve
5 of Fig. 6;

Fig. 10 is a longitudinal cross-sectional view taken along line 10-10 of Fig. 7;

Fig. 11 is a transverse cross-sectional view taken along line 11-11 of Fig. 7;

Fig. 12 is a longitudinal cross-sectional view taken along line 12-12 of Fig. 7;

Fig. 13 is a top plan view of the expandable heart valve taken along line 13-13 of
10 Fig. 7;

Fig. 14 is an enlarged perspective view of a commissure region of the expandable heart valve taken within the circle 14 of Fig. 7;

Fig. 15 is an enlarged plan view of the commissure region of the expandable heart valve taken within the circle 15 of Fig. 13; and

Fig. 16A-C illustrate a heart in section and several steps in a delivery and
15 implantation procedure of the expandable valve of the present invention.

Description of the Preferred Embodiments

The present invention discloses two different expandable heart valves for
20 implantation in a host annulus, or host tissue adjacent the annulus. The valves may be implanted in any of the four valve positions within the heart, but are more likely to be used in replacing the aortic valve because of the circular shape of the annulus.

It should also be noted that the specific constructional details, including materials and shapes, may be varied from those shown. For example, an expandable tubular base
25 is used in both valve embodiments, and is described as being a plastically-expandable structure that radially expands into contact with the annulus tissue. Alternatively, the tubular base may be elastically- or self-expandable, or expandable on the application of heat (i.e., using shape memory material). Further, various means are known for plastically or elastically expanding structures into contact with anatomical passageways,
30 and though the present invention illustrates and describes only one such structure, others may be used to practice the invention. For example, any plastically- or elastically-expandable structure may be modified so as to have a suitable diameter for heart valves

and used to practice the present invention. In addition, barbs, flanges, staples, and the like may be added to the tubular base for the purpose of greater attachment to the host tissue. In short, the present invention should not be construed to be limited to the particular structures and materials disclosed, the scope of the invention being solely
5 defined by the appended claims.

With reference to Figs. 1-5, a first embodiment of an expandable prosthetic heart valve 20 is shown and described. The prosthetic heart valve 20 is assembled prior to storage. In a second embodiment, shown in Figs. 6-15, a second embodiment of an expandable heart valve is shown and described. Detachable components of the
10 expandable heart valve in the second embodiment are separately stored, and assembled just prior to insertion and delivery to the host annulus, which provides certain advantages to be described.

Pre-Assembled Expandable Heart Valve

15 Fig. 1 illustrates the first embodiment of the expandable heart valve 20 exploded, with a flexible tubular member 22 separated from a support stent 24 along a central axis 26. Fig. 2 illustrates the flexible tubular member 22 attached to the support stent 24 to form the assembled heart valve 20. The heart valve 20 has an inflow end 28 (the lower end in the figure) and an outflow end 30 (the upper end in the figure).

20 The flexible tubular member 22 comprises a leaflet section 32 connected to a fabric section 34 at a seam 36. As illustrated, both the leaflet section 32 and fabric section 34 are desirably formed as tubes, such that the seam 36 defines a circle therebetween. Alternatively, the seam 36 may be other than circular if areas of the leaflet section 32 or fabric section 34 need to be expanded around their circumferential juncture.
25 For example, the fabric section 34 may need to be increased in the commissure region of the valve 20, such as indicated by the dashed line 38 in Fig. 1. Whatever the configuration, the fabric section 34 has a minimum axial height indicated at A.

Desirably, the leaflet section 32 is formed from pericardial tissue, such as bovine or equine pericardium, suitably treated to render it biocompatible. Of course, any
30 suitable leaflet material, including synthetics, may be used. The fabric section 34 is desirably a woven polyester, such as polyethylene terephthalate. Alternatively, the fabric section 34 may be formed of polytetrafluoroethylene (PTFE), or other suitable

biocompatible sheet material. Still further, the leaflet section 34 may extend the entire axial height of the flexible tubular member 22, with the fabric section 34 being wrapped around and attached to the inflow end.

As seen in Fig. 1, the support stent 24 comprises a tubular base 40 and a plurality
5 of upstanding commissure posts 42 distributed evenly around the periphery thereof. That is, the tubular base 40 is provided at the inflow end 28 of the support stent 24, with the commissure posts 42 extending in the outflow direction. Desirably, there are three such commissure posts 42 disposed at 120° intervals about the circumference of the stent 24. The tubular base 40 has an axial height indicated at **B**, which height is less than the axial
10 height **A** of the fabric section 34 of the flexible tubular member 22. The commissure posts 42 extending upward a sufficient distance such that the entire axial dimension of the support stent 24 is slightly greater than the axial dimension of the flexible tubular member 22, as indicated in the assembled view of Fig. 2.

The tubular base 40 comprises a plastically-expandable material that can be
15 expanded into the configuration shown in the figures from a radially compressed configuration (not shown). In this regard, the illustrated tubular base 40 essentially comprises a non-self expanding stent that can be expanded from its compressed state using a balloon inflated from within the base, for example. Numerous configurations of such plastically-expandable tubes are available in the prior art, and as mentioned above,
20 the present invention should not be considered limited to any one configuration. Moreover, in other configurations the base 40 may be self- or heat-expandable.

With reference to Fig. 1, each commissure post 42 attaches to or extends from an inflow rim 44 of the tubular base 40, continuing on the outside of the tubular base toward the outflow end in an elongated axially-extending lower section 46, and terminating in an
25 axially extending upper section 48. The upper section 48 commences at a predetermined distance above an outflow rim 50 of the tubular base 40 and is stepped radially inward from the lower section 46 at a transition region 52. An axial slot 54 is provided in the upper section 48 and in the transition region 52. The width of the axial slot 54 is desirably constant in the upper section 48, but increases at a relief region 56 in the
30 transition region 52.

In a preferred embodiment, the commissure posts 42 are formed of a biocompatible, elastic material, preferably metallic. For example, each commissure post

42 may be formed of stainless-steel, titanium, or Elgiloy. Alternatively, the commissure posts 42 may be a biocompatible polymer, such as Delrin or polyacetyl.

In a preferred embodiment, the support stent 24 is formed from a single piece of flat material. Specifically, the tubular base 40 initially comprises a flat, narrow strip of uniform width material with the commissure posts 42 extending from one long side thereof. Using conventional means, the narrow strip of material is then rolled into the tubular shape shown in the figures, and the juxtaposed narrow ends joined by, for example, crimping. Each of the commissure posts 42 is then bent 180° outward to project in the opposite direction from their original direction. Fig. 1 illustrates such a configuration in which a 180° bend 60 joins each commissure post 42 to the inflow rim 44. The radius of the bend 60 is such that a narrow space 62 is defined between the lower section 46 of each commissure post 42 and the exterior of the tubular base 40.

The flexible tubular member 22 attaches to the support stent 24 as seen in Fig. 2, with the leaflet section 32 connected to the commissure posts 42, and the fabric section 34 connected to the tubular base 40. More specifically, the fabric section 34 surrounds the tubular base 40 and extends toward the inflow rim 44 in the spaces 62 created inboard of each commissure post 42. Although not shown, the fabric section 34 may be attached to the exterior of the tubular base 40, such as by sutures passed through the fabric and through openings in the tubular base. Because the axial dimension **A** of the fabric section 34 is greater than the axial dimension **B** of the tubular base 40, the seam 36 is disposed above the outflow rim 50 (Fig. 1) of the base. This is more clearly shown in the cross-section of Fig. 3.

The leaflet section 32 is disposed substantially between the commissure posts 42, except for a number of loops 70 threaded outward through the axial slots 54. As seen in Figs. 2-3, the loops 70 comprises regions of the tubular leaflet section 32 pinched and threaded through the axial slots 54. A plurality of inserts 72 are used to secure the loops 70 to the exterior of the commissure posts 42. That is, as seen Fig. 4, the inserts 72 each have a width **W** that is greater than the circumferential width of the axial slots 54. Because the inserts 72 are disposed within the loops 70, they prevent the loops from pulling inward again through the axial slot 54. A plurality of stitches 74 are preferably provided to secure the leaflet section 32 to the inserts 72. In addition, as seen in Fig. 3, stitching 76 passes through an aperture 78 in each insert 72, and through an aperture 80

provided in the outflow end of each commissure post 42. In this manner, each insert 72 is secured with respect to the support stent 24.

With reference to Figs. 2 and 5, a plurality of leaflets 82 are defined between the support stents 24 by the leaflet section 32. Specifically, where there are three stent post
5 24, a generally triangular arrangement of leaflets 82 remains unconstrained in the middle portion of the valve 20 and opens and closes depending on blood flow forces. Furthermore, the continuous flexible tubular member 22 provides a flow channel for blood through the valve 20. When the pressure differential is such that blood flows into the inflow end 28 of the valve 20, the leaflets 82 spread apart and the valve opens.
10 Conversely, when the pressure differential reverses, the leaflets 82 come together, or coapt, to close the valve 20.

When the pressures are such that the valve closes, radially inward forces are imposed on the free edge of the leaflet section 32, which may tend to cantilever the support stents 24 inward a slight amount. Localized stresses on the leaflet section 32 are
15 reduced at the connection with the stent supports 24, however, because of the use of the inserts 72 within the loops 70. That is, as best seen in Fig. 4, radially inward forces on the leaflets 82 as indicated by the arrow 84, pull the inserts 72 inward such that the leaflet material is clamped between each insert and the respective commissure post 42. Although stitching 74 through the leaflet section 32 is provided, such stitching is not
20 subjected to direct tensile stresses, and thus is less likely to tear through the leaflet tissue.

Certain features of the valve 20 reduce wear typically associated with stent-leaflet dynamic contact. First, because the axial dimension **A** of the fabric section 34 is greater than the dimension **B** of the tubular base 40, any contact between the flexible tubular member 22 and the tubular base 40 (at the outflow rim 50) is between fabric and the
25 base. That is, the leaflet section 32 is not placed in contact with the base 40, thus increasing the life of the valve. Additionally, the enlarged relief region 56 of the slot 54 in the transition region 52 helps reduce the rubbing that might otherwise occur between the commissure posts 42 and the leaflets 80. That is, the leaflet section 32 continues substantially axially downward from the loops 70, as seen in Fig. 3, and the relief region
30 56 provides a small gap in the transition region 52 between the leaflet tissue and the sides of the slot 54 to help prevent rubbing therebetween.

In use, the assembled heart valve 20 as seen in Fig. 2 is initially provided in a

radially compacted configuration (not shown). Preferably, the valve 20 is loaded about a balloon catheter and within a delivery cannula. The balloon catheter with the valve 20 loaded thereon is then passed through the patient's vasculature (or through an access port in the chest) into proximity with the host annulus. Alternatively, where the chest of the patient is opened, the reduced size valve 20 is inserted into position using a holder.

Once in position within the annulus of the valve being replaced, the balloon (or other expanding means) causes the tubular base 40 to expand into contact with the annulus. Actually, because the commissure posts 42 and fabric section 34 surround tubular base 40, these elements are compressed against the host annulus. Because the tubular base 40 is plastically-expandable, it substantially retains its expanded shape. A slight over-expansion of the tubular base 40 may be required to compensate for any elastic spring-back character of the material used. Again, barbs or staples may also be utilized to further secure the valve 20 and in place. Ultimately, the balloon catheter is deflated and removed from within the valve 20.

15

Expandable Heart Valve Assembled Post-Storage

Figs. 6-15 illustrate an expandable prosthetic heart valve 100 including, as best seen in Fig. 6, a leaflet subassembly 102 adapted to connect to a tissue-engaging base 104. The two components are both shown in Fig. 6 in their radially expanded configurations, though both are designed to be radially compressed and delivered through a catheter or cannula, for example. In contrast with the first embodiment, however, the two components are stored separately, and connected just prior to delivery into the body of the patient. In general, the two components provide a tissue-engagement ring and a relatively more flexible valve member having fluid occluding surfaces. It should be understood that configurations of these two connectable components other than those specifically shown may be encompassed by the appended claims.

As seen in Fig. 6, the leaflet subassembly 102 comprises an elastic wireform 106 supporting a plurality of prosthetic leaflets 108, and a fabric skirt 110. The wireform 106 comprises a continuous undulating pattern of alternating commissures 112 and cusps 114. Preferably, the valve 100 is a tri-leaflet type, such that the wireform 106 has three commissures 112 and three cusps 114, with three leaflets 108 support thereby. In particular, each leaflet 108 is desirably attached to adjacent commissures 112, and along

the entire arcuate cusp 114 therebetween. As will be described in more detail below, the leaflets 108 each attach to a fabric covering 116 around the wireform cusps 114. In a preferred embodiment, the elastic wireform 106 is formed of a biocompatible, elastic material, preferably metallic. For example, the elastic wireform 106 may be formed of stainless-steel, titanium, or Elgiloy. Alternatively, the elastic wireform 106 may be formed from a biocompatible polymer, such as Delrin or polyacetyl. In this sense, therefore, the term "wire" in wireform should not be construed as limiting the material to metallic.

Fig. 7 illustrates an assembled valve 100 with the fabric skirt 110 shown in Fig. 6 removed for clarity. That is, the fabric skirt 110 is sized to drape outside of and surround the tissue-engaging base 104, but is removed in Fig. 7 to show the connection details between the base and the leaflet subassembly 102. The valve 100 defines an inflow end 120 and an outflow end 122.

Fig. 9 illustrates an exemplary leaflet 108 having an arcuate cusp edge 124 opposite a linear coapting edge 126. The cusp edge 124 is generally semi-circular, and terminates at commissure portions 128. A pair of oppositely-directed tabs 130 extend outward from both ends of the coapting edge 126, and are seen in Fig. 6 prior to attachment to the wireform 106. That is, the tabs 130 from adjacent leaflets 108 join together and pass through the inverted U-shaped commissures 112 of the elastic wireform 106. In a preferred embodiment, each leaflet 108 is formed from pericardial tissue, such as bovine or equine pericardium, or a synthetic material, that has been suitably treated to render it biocompatible.

With reference again to Fig. 6, the cusp edge 124 of each leaflet 108 is shaped so as to follow a cusp 114 of the elastic wireform 106. The fabric skirt 110 extends to an inflow edge 132 from each of the cusps 114, and when the skirt is assembled to the tissue-engaging base 104, the inflow edge extends substantially to the inflow end 120 (Fig. 7) of the valve. The fabric skirt 110 further terminates at outflow edges 134 between adjacent wires of the wireform commissures 112, below the leaflet tabs 130 extending therethrough. The skirt 110 may be made of a biocompatible fabric such as polyester, or of other suitable biocompatible sheet material.

The leaflet subassembly 102 attaches to the tissue-engaging base 104 at discrete locations, securely coupling each of the commissures 112 and cusps 114 of the elastic

wireform 106 to the base. As seen best in Fig. 6, the tissue-engaging base 104 comprises a tubular plastically-expandable member 140 having an inflow rim 142 and outflow rim 144. A plurality of commissure posts 146 are either rigidly attached to, or securely coupled to, the tubular member 140 so as to extend generally axially beyond the outflow rim 144 in the outflow direction. Likewise, a plurality of cusp posts 148 are rigidly attached to, or securely coupled to, the tubular member 140 so as to extend beyond the outflow rim 144. Because the commissure posts 146 couple to the wireform commissures 112, they are longer than the cusp posts 148 that couple to the wireform cusps 114.

As illustrated, both the commissure posts 146 and cusp posts 148 extend through upper and lower sleeves 150a, 150b, respectively provided on the exterior of the tubular member 140, and are desirably axially secured therein. It should be noted that this is only one of numerous possible ways to rigidly couple upstanding posts to a plastically-expandable tubular member. However, the posts 146,148 are desirably located on the outside of the tubular member 140 so as not to interfere with a balloon for expanding the tubular member from the inside, nor to interfere with blood flowing through the valve. It should also be noted that in a reverse configuration, the posts 146, 148 may be initially attached to the wireform commissures 112 and cusps 114, respectively, as part of the leaflet subassembly 102 and subsequently connected to mating structures (not shown) provided on the tissue-engaging base 104.

A plurality of connectors are provided for attaching the elastic wireform 106 to the posts 146, 148 of the tissue-engaging base 104. In particular, as seen in Fig. 6, each commissure post 146 provides a lower commissure connector 160 thereon. Likewise, each cusp posts 148 provides a lower cusp connector 162. In the illustrate embodiment, the outflow end of each of the posts 146, 148 is bent 90° to face radially inward, and a groove formed therein defines the respective connectors 160,162.

Figs. 9-11 illustrate the configuration of the connection between the leaflet subassembly 102 and tissue-engaging base 104 at the commissures of the valve. With specific reference to Fig. 10, the lower commissure connector 160 of the commissure post 146 mates with an upper commissure connector 164 of an insert 166 (isolated in Fig. 8) secured to the wireform commissure 112. As seen in Fig. 11, adjacent leaflets 130 extend radially outward between spaced wires of the wireform 106 and wrap around the

insert 166 to be connected on an outer side thereof with a plurality of stitches 168. Fig. 8 illustrates one form of the insert 166 wherein the upper commissure connector 164 comprises a downwardly opening partial circle which mates with the groove of the lower commissure connector 160, as seen in Fig. 10. In this manner, the commissures 112 are
5 securely fastened with respect to the tissue-engaging base 104 by virtue of the interaction between the lower commissure connector 160 and upper commissure connector 164.

With reference again to Figs. 6 and 7, a plurality of upper cusp connectors 170 attach to the approximate midpoint of each of the cusps 114 of the wireform 106. Each upper cusp connectors 170 is configured and positioned to mate with the lower cusp
10 connector 162 formed on each of the cusp posts 140. Again, the upper cusp connector 170 may be provided with a downwardly opening partial circle that mates with the groove of the lower cusp connector 162.

With specific reference to Fig. 12, certain constructional details of the valve cusps are further illustrated. The fabric covering 116 of the wireform 106 is shown as a tube
15 having an upper fabric extension 180 and a lower fabric extension 182 sandwiched around a radial portion 184 of the upper cusp connector 170. The upper cusp connector 170 extends outward and bends 90° downward to mate with the lower cusp connector 162. The upper fabric extension 180 continues outward and downward in the fabric skirt 110. The lower fabric extension 182 bends 180° underneath the cusp edge 124 of the
20 respective leaflet 108. Stitching 186 secures the combined layers of the upper extension 180, radial portion 184, first part of the lower extension 182, leaflet cusp 124, and wrapped-around portion of the lower extension 182.

Desirably, both the insert 166 and upper cusp connector 170 are made from a suture-permeable material having sufficient strength to maintain the connections between
25 the leaflet subassembly 102 and tissue-engaging base 104. For example, the insert 166 and connector 170 may be made of Delrin, or other suitable polymer. As illustrated, each of the connectors 164 and 170 are partial circles that fit around tubular grooves in the respective posts 146,148. Of course, other arrangements are possible, and the present invention should not be considered limited to those connectors illustrated.

30 As with the earlier embodiment, the valve 100 utilizes a low-stress connection between the leaflets 108 and the elastic wireform 106. In particular, as seen in Fig. 11, the provision of the insert 166 provides a clamping force during diastole between the

insert and the wireform 106 against the portion of the leaflets 108 therebetween. The stitching 168 is not subjected to direct tensile stresses, and there is thus less chance for tearing.

Leaflet subassembly 102 is desirably stored in its expanded state, as seen in Fig. 6 (which, as mentioned, does not illustrate the commissure attachment structure). That is, the wireform 106 and leaflets 108 may be stored immersed in a preservative such as glutaraldehyde in a sterile container until needed. In this regard, the prosthetic leaflets 108 remain in their functional shape during storage. This greatly reduces adverse wrinkling or other permanent or semi-permanent damage to the leaflets over time, and improves the quality of the valve 100. At the same time, the base 104 desirably does not include any bioprosthetic or otherwise perishable components, and thus may be stored in a separate dry sterile container. This method also permits the combination of different bases with any one leaflet subassembly 102, or visa versa. For example, the type of attachment mechanism (i.e., staples, barbs, sutures, etc.) of the base 104 to the annulus may be selected by the surgeon, with different bases being attached in different ways, and all being combinable with a particular leaflet subassembly 102. Also, the type of base may be selected based on patient indications; with a self-expanding base being preferred in some situations and a balloon-expanded base in others.

In use, the leaflet subassembly 102 is compressed from its expanded configuration to a size corresponding to the tissue-engaging base 104 in its compressed state (not shown). If the tissue-engaging base 104 is plastically deformable then it is initially supplied in its compressed state. Alternatively, a self-expandable base 104 will have to be compressed either before or after connection to the similarly configured leaflet subassembly 102. Compression of the leaflet subassembly 102 (and base if necessary) may be accomplished using a tapered mandrel through which the subassembly is passed, or with a cinch or other direct constricting means. The two components are then connected together, just prior to insertion into the patient's body, and the valve 100 delivered simultaneously to the host annulus site. To connect the two components, the fabric skirt 110 is passed around the outside of the commissure posts 146 and around the tubular member 140. Each of the upper connectors 164 and 170 are caused to mate with the lower connectors 160, 162. In the illustrated embodiment, such a mating operation simply requires forcing each of the partial circles defining the upper connectors over the

grooves defining the lower connectors. The partial circles open slightly, but then spring inward when the connectors snap together and the groove is fully seated.

There are a number of ways to deliver the valve 100 to the aortic annulus. For one, the tubular member 140 may be mounted around a balloon catheter and inserted via
5 an introducer or other cannula into the patient's vasculature and to the aorta. Alternatively, an open-heart procedure or less-invasive port procedure may be utilized, with the tissue-engaging base 104 being delivered to the host annulus using a holder or other such means.

Fig. 16A depicts a sectional view of a heart 200 having a left ventricle chamber
10 202 opening to an ascending aorta 204 through an aortic annulus 206. The ascending aorta 204 continues over an aortic arch 208, and branches off into several upper body arteries 210 before descending to the abdominal aorta (not shown). As mentioned above, the expandable valves of the present invention can be delivered into proximity of the aortic annulus 206 in several ways, including through the patient's vasculature as shown.

15 In particular, a valve delivery catheter 212 is shown in the cutaway portion of the ascending aorta 204, having been introduced along the direction of the arrow 214 so that a distal end thereof lies adjacent the aortic annulus 206. The catheter 212 can be introduced percutaneously into the patient's arterial system (e.g. into a peripheral artery such as the femoral artery) and advanced to the ascending aorta 204. The catheter shaft
20 preferably has a length of at least about 80 cm, usually about 90-100 cm, to allow transluminal positioning of the shaft from the femoral and iliac arteries to the ascending aorta. Alternatively, the shaft may have a shorter length, e.g. 20-60 cm, for introduction through the iliac artery, through the brachial artery, through the carotid or subclavian arteries, or through a penetration in the aorta itself. In the femoral approach, the catheter
25 is long enough and flexible enough to traverse the path through the femoral artery, iliac artery, descending aorta and aortic arch. At the same time, the catheter has sufficient pushability to be advanced to the ascending aorta by pushing on the proximal end, and has sufficient axial, bending, and torsional stiffness to allow the physician to control the position of the distal end, even when the catheter is in a tortuous vascular structure.
30 Alternatively, the catheter 212 may be passed through a port between ribs in the patient's thorax above the heart and through an incision in the aortic arch 208, in a so-called minimally-invasive procedure.

Techniques for introducing catheters into the human vasculature are well-known, and typically involve the introduction of a guidewire 216 first, followed by an obturator or dilator (not shown) within a sheath 218. The dilator facilitates introduction of the catheter sheath 218 into the vasculature, and is then removed, though the guidewire 216 typically remains in place. Subsequently, a valve of the present invention, such as valve 100 seen in Figs. 6-15, is delivered over the guidewire 216 and to the distal end of the sheath 218. In accordance with one aspect of the present invention, the valve 100 includes a balloon-expandable portion and thus is mounted over an expansion balloon 222. To facilitate passage of the valve 100 through the sheath 218, a pusher 224 may be used.

Fig. 16B illustrates a second step in the exemplary valve delivery procedure in which the sheath 218 is retracted in a proximal direction as indicated by arrow 226. Retraction of the sheath 218 exposes the valve 100, which is positioned within the aortic annulus 206 with the assistance of fluoroscopy and radiopaque markers, ultrasonic imaging, or the like. If the valve 100 includes self-expanding components, retraction of the sheath 218 releases the outer restraint on the valve and permits it to expand into contact with the annulus 206. In the illustrated embodiment, however, the tubular member 140 of the tissue-engaging base 104 is plastically-deformable and retains its radially constricted configuration after retraction of the sheath 218. Because of the rigid connections between the leaflet subassembly 102 and the base 104, the subassembly also remains in its constricted configuration.

Finally, in Fig. 16C, the balloon 222 is inflated to cause the tissue-engaging base 104 to radially expand into contact with the aortic annulus 206, as indicated by the arrows 230. Simultaneously, the leaflet subassembly 102 radially expands by virtue of the rigid connection with the base 104, and by virtue of its spring bias. A balloon inflation catheter 232 is seen projecting from the pusher 224 and through the leaflet subassembly 102. With reference back to Fig. 6, the fabric skirt 110 is captured between the tubular member 140 and the surrounding tissue, and is in direct contact therewith. Therefore, by virtue of the continuous connection between the cusp edges 124 of the leaflets 108 and the fabric skirt 110, the skirt forms a flow channel for blood entering the inflow end 120 of the valve 100. Again, the plastically-expandable tubular member 140 may be slightly over-expanded to account for any spring-back in the material. Further, as

mentioned above, the tubular member 140 may include staples or barbs or other such attachment structure for securely locating the valve 100 within the annulus 206.

Once the valve 100 is fully expanded and securely attached to the annulus 206, the balloon 222 is deflated and removed. Such an operation may include elongating the
5 balloon 222 in the distal direction and reducing its radial dimension by, for example, twisting. Care must be taken so as not to damage the leaflets within the subassembly 102 during retraction of the balloon 222 therethrough. After the balloon 222 has been retracted within the sheath 218, the entire catheter 212 is removed from the patient.

The fully formed valve 100 has a number of distinct advantages over prior
10 expandable valves. For example, as mentioned above, the prosthetic leaflets 108 may be stored in the final, uncompressed implantation shape. This is in contrast to prior expandable valves where the entire valve may be initially compressed such that the leaflets are stored in a compressed state. Consequently, valves of the prior art can be stored for years prior to use, and permanent wrinkling of the compressed leaflets may be
15 a real problem.

Furthermore, each of the leaflets 108 is supported substantially entirely around the undulating wireform 106, which has proven to provide optimal valve performance. Also, separate leaflets are used as opposed to a continuous tube, as in the first
20 embodiment. Additionally, the advantageous low-stress attachment structure of the leaflet tabs 130 to the wireform commissures 112 further increases the durability of the valve.

While the foregoing is a complete description of the preferred embodiments of the invention, various alternatives, modifications, and equivalents may be used. Moreover, it will be obvious that certain other modifications may be practiced within the
25 scope of the appended claims.

1. A two-part prosthetic heart valve from implantation within a native heart valve, comprising:

a tissue-engageable base expandable from a collapsed state to an expanded state, the collapsed state sized for advancement through a patient's vasculature to a heart valve annulus and the expanded state sized to engage the heart valve annulus, the tissue-engageable base having an outflow rim and a plurality of commissure posts rigidly attached to extend beyond the outflow rim and a plurality of cusp posts rigidly attached to extend beyond the outflow rim

a leaflet subassembly including a support structure and three heart valve leaflets the leaflets being attached to the support structure at respective commissures, wherein the support structure comprises an elastic wireform for supporting the leaflets and wherein the wireform provides alternating commissures and cusps; and

a plurality of discrete mating connectors on the leaflet subassembly and tissue-engageable base, one each on the leaflet subassembly and base forming a pair of mating connectors, the mating connectors configured to mechanically couple the leaflet subassembly to the tissue-engageable base when the tissue-engageable base is in the expanded state, each commissure post and cusp post having one of the mating connectors thereon for securely coupling to a mating connector on one of the commissures and cusps of the elastic wireform.

2. The two-part prosthetic heart valve of claim 1, wherein the tissue-engageable base is plastically-expandable from the collapsed state to the expanded state.

3. The two-part prosthetic heart valve of claim 1, wherein each pair of the mating connectors joins by axially displacing the leaflet subassembly toward the tissue-engageable base.

4. A two-part prosthetic heart valve for implantation within a native heart valve, comprising:

a tissue-engageable base expandable from a collapsed state to an expanded state, the collapsed state sized for advancement through a patient's vasculature to a heart valve annulus and the expanded state sized to engage the heart valve annulus, the tissue-engageable base further including an outflow rim and a plurality of commissure posts rigidly attached to the tissue-engageable base so as to extend generally axially beyond the outflow rim, and a plurality of cusp posts rigidly attached to the tissue-engageable base so as to extend beyond the outflow rim;

an expandable leaflet subassembly including a support structure and three heart valve leaflets, the leaflets being attached to the support structure at respective commissures, the leaflet subassembly being expandable from a collapsed state to an expanded state, wherein the support structure comprises an elastic wireform with alternating commissures and cusps for supporting the leaflets; and

a plurality of axially extending discrete mating connectors on the leaflet subassembly and tissue-engageable base, one each on the leaflet subassembly and base forming a pair of mating connectors, wherein each commissure post and cusp post of the tissue-engageable base has one of the mating connectors thereon for securely coupling to a mating connector on one of the commissures and cusps of the elastic wireform, wherein axial displacement of the leaflet subassembly in its expanded state toward the expanded tissue-engageable base in its expanded state actuates a mutual coupling mechanism on the pairs of mating connectors so as to mechanically couple the leaflet subassembly to the tissue-engageable base.

5. The two-part prosthetic heart valve of claim 4, wherein the tissue-engageable base is plastically-expandable from the collapsed state to the expanded state.

6. The two-part prosthetic heart valve of claim 4, wherein mating connectors on the leaflet subassembly are provided on each of the commissures and cusps of the elastic wireform.

7. The two-part prosthetic heart valve of claim 4, wherein the mating connectors are joined together by axial compression.

8. The two-part prosthetic heart valve of claim 7, wherein the mating connectors are configured to snap fit together.

9. The two-part prosthetic heart valve of claim 7, wherein one of each pair of mating connectors comprises a partial circle opening in an axial direction toward the other of the pair.

1/10

Fig. 1

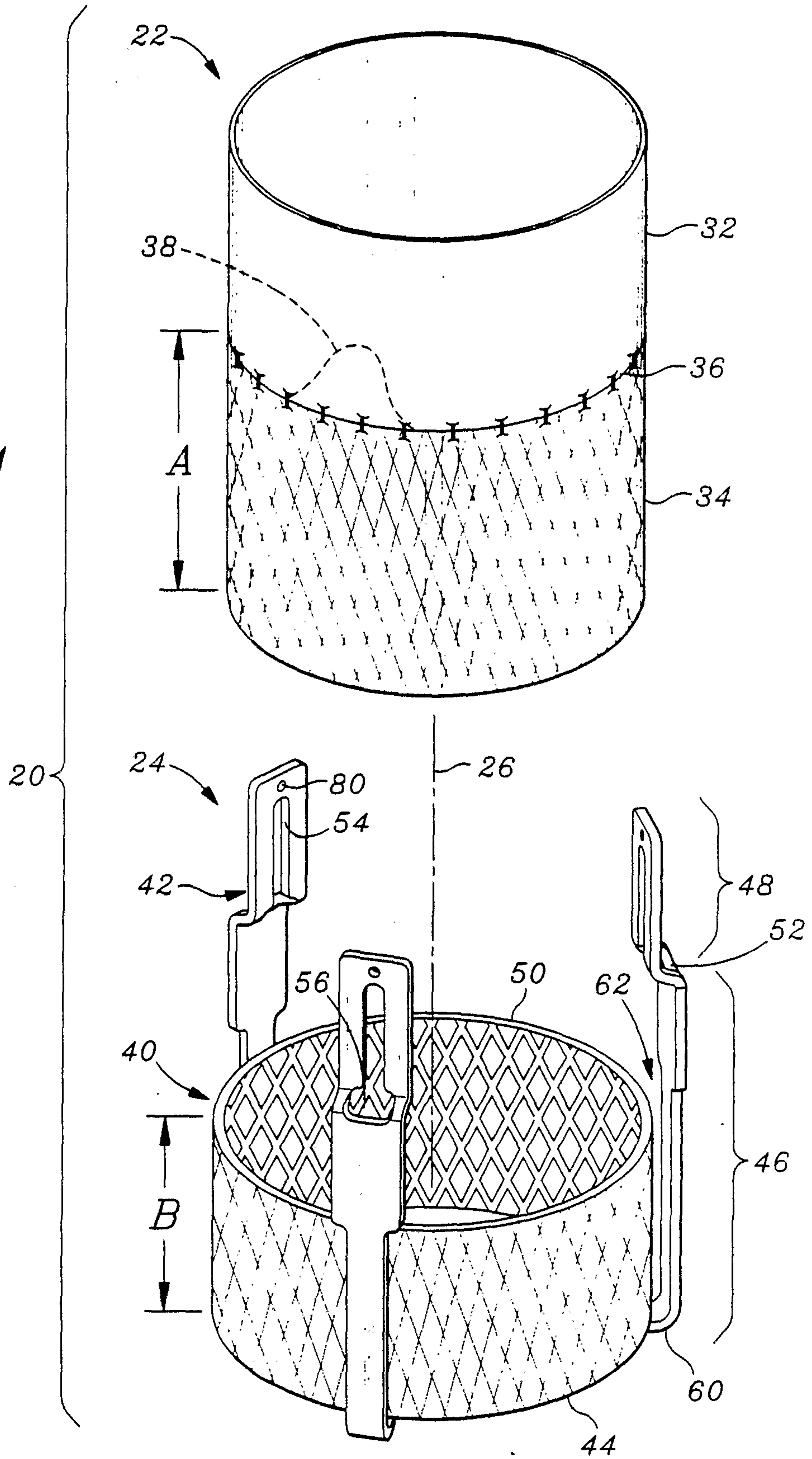

2/10

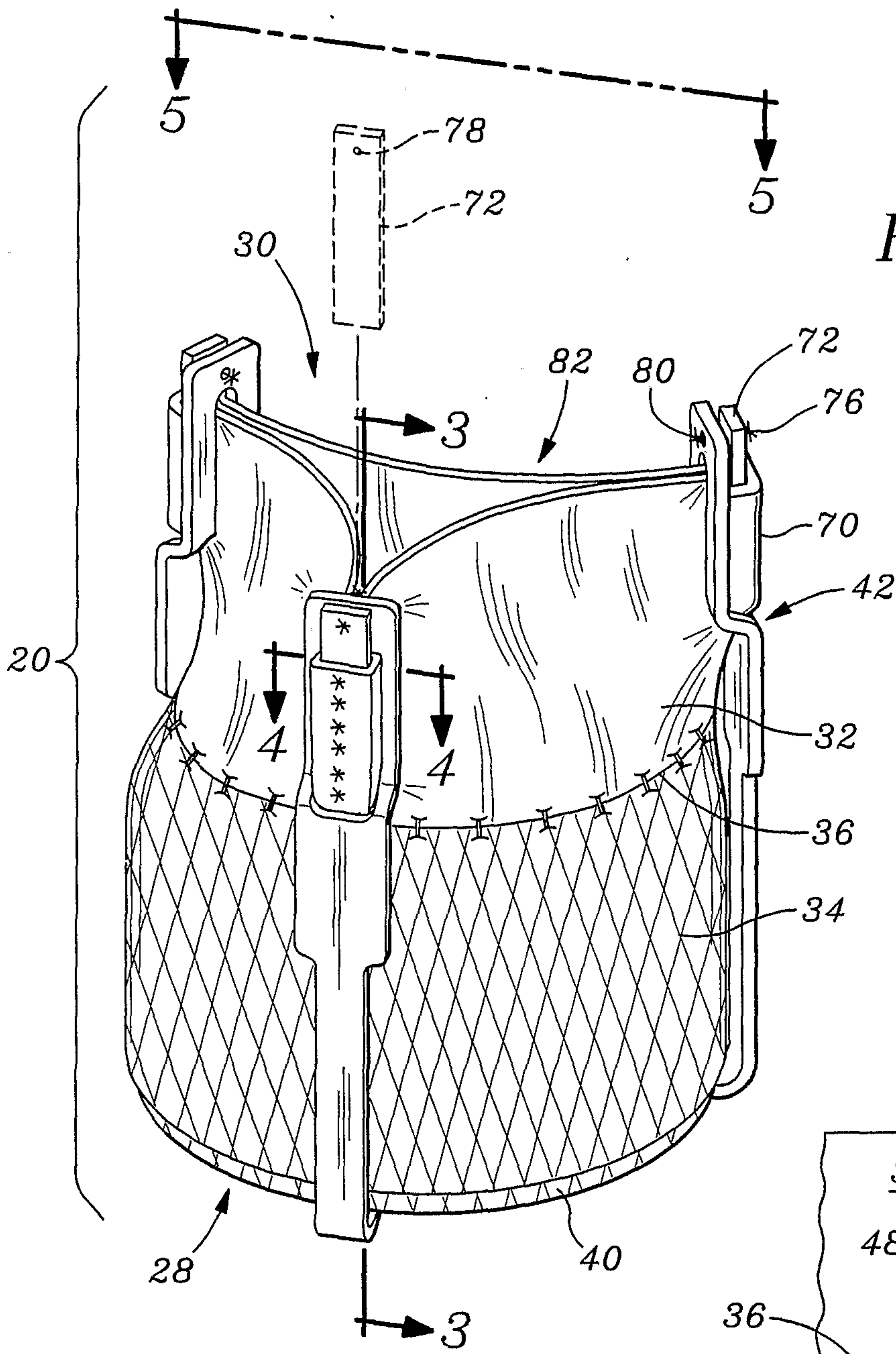

Fig. 2

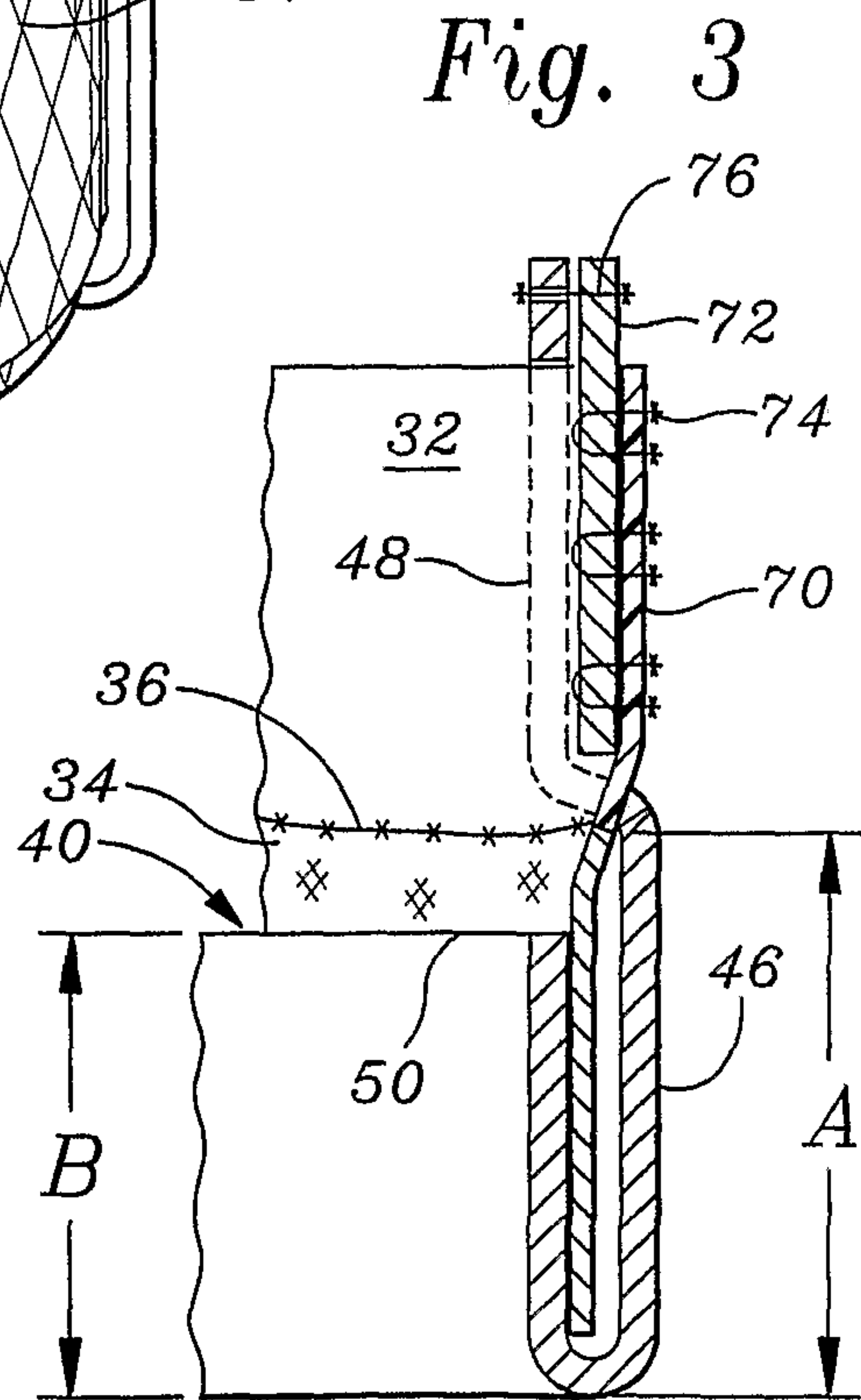

Fig. 3

3/10

Fig. 4

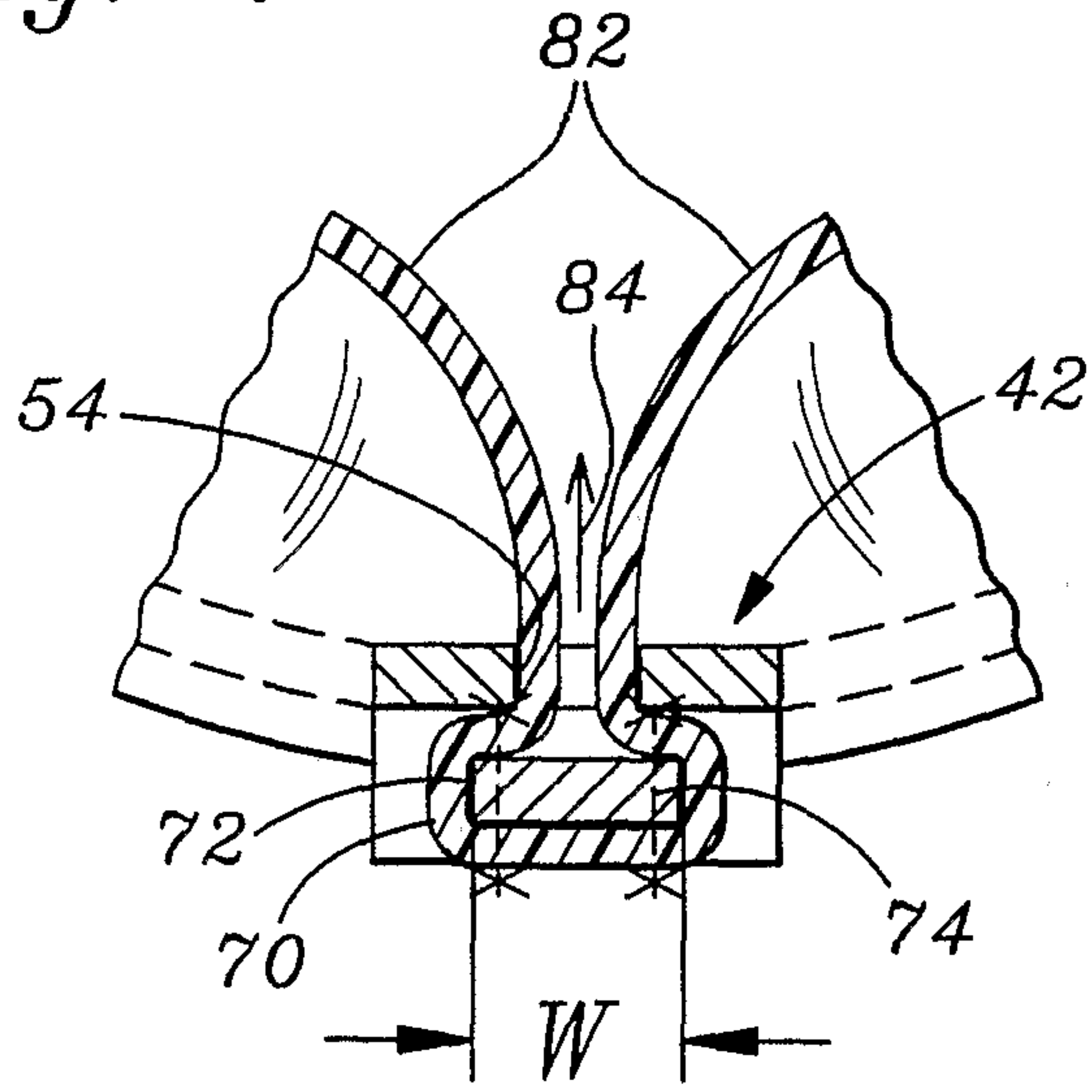

Fig. 5

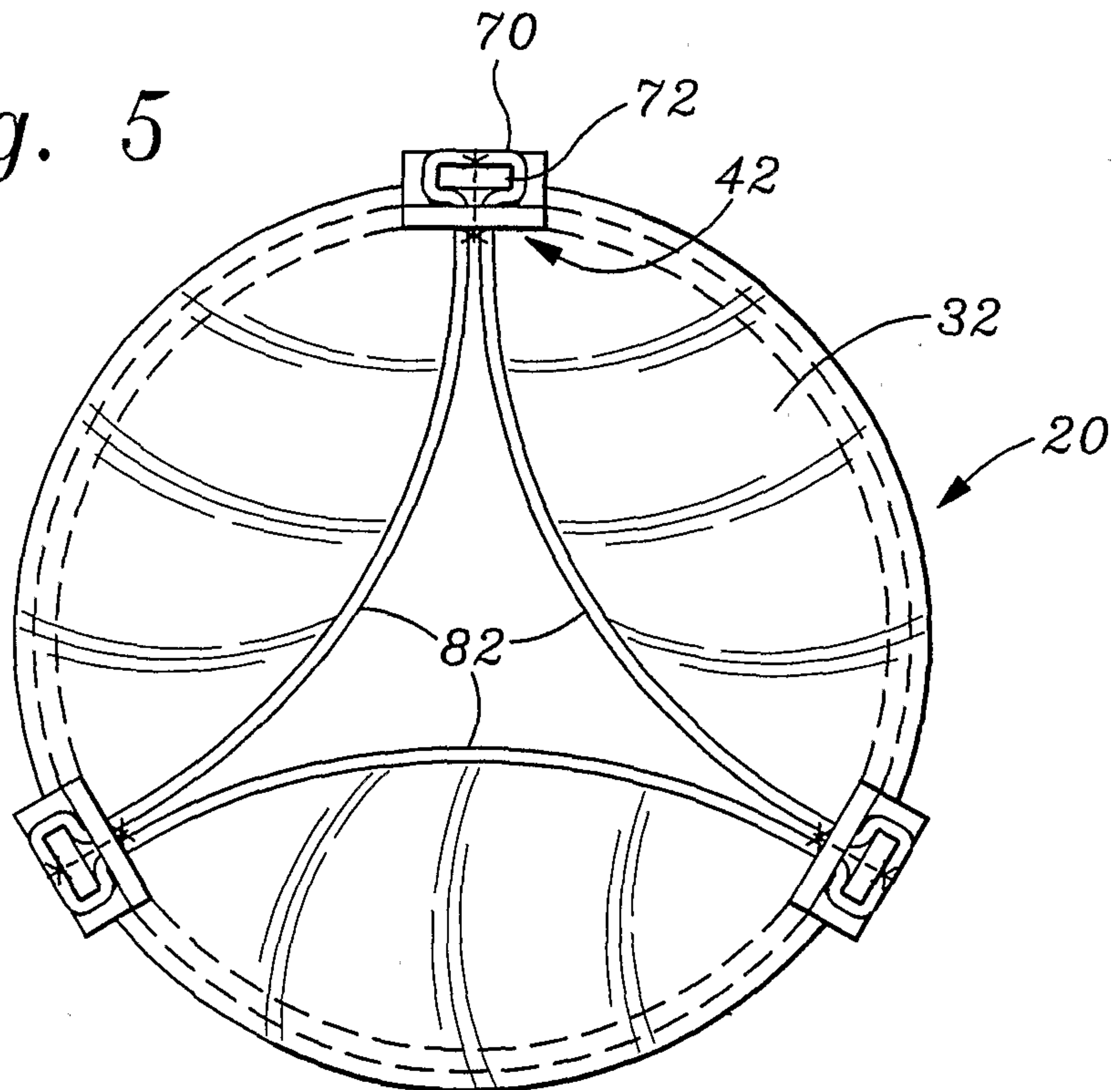
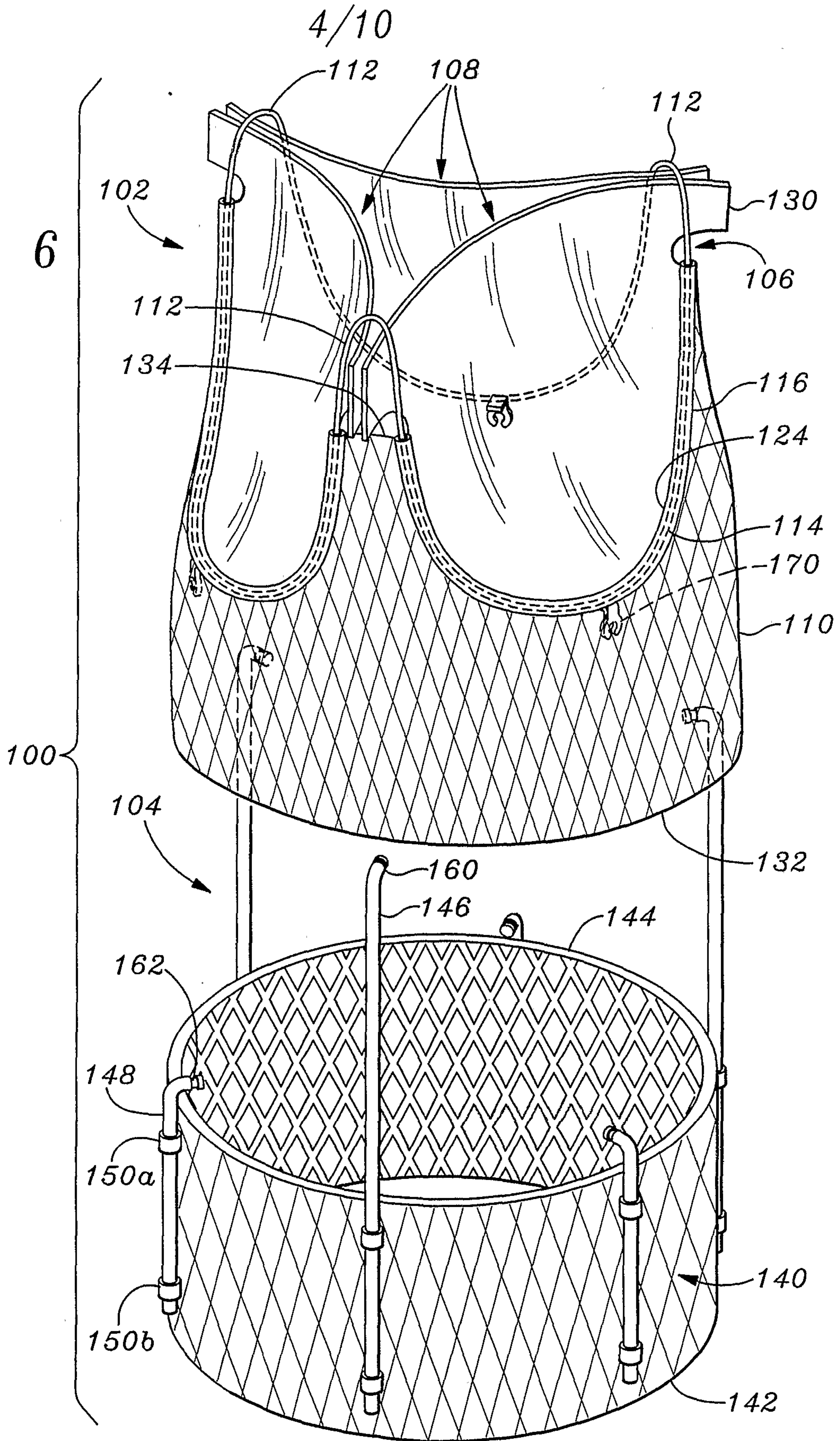
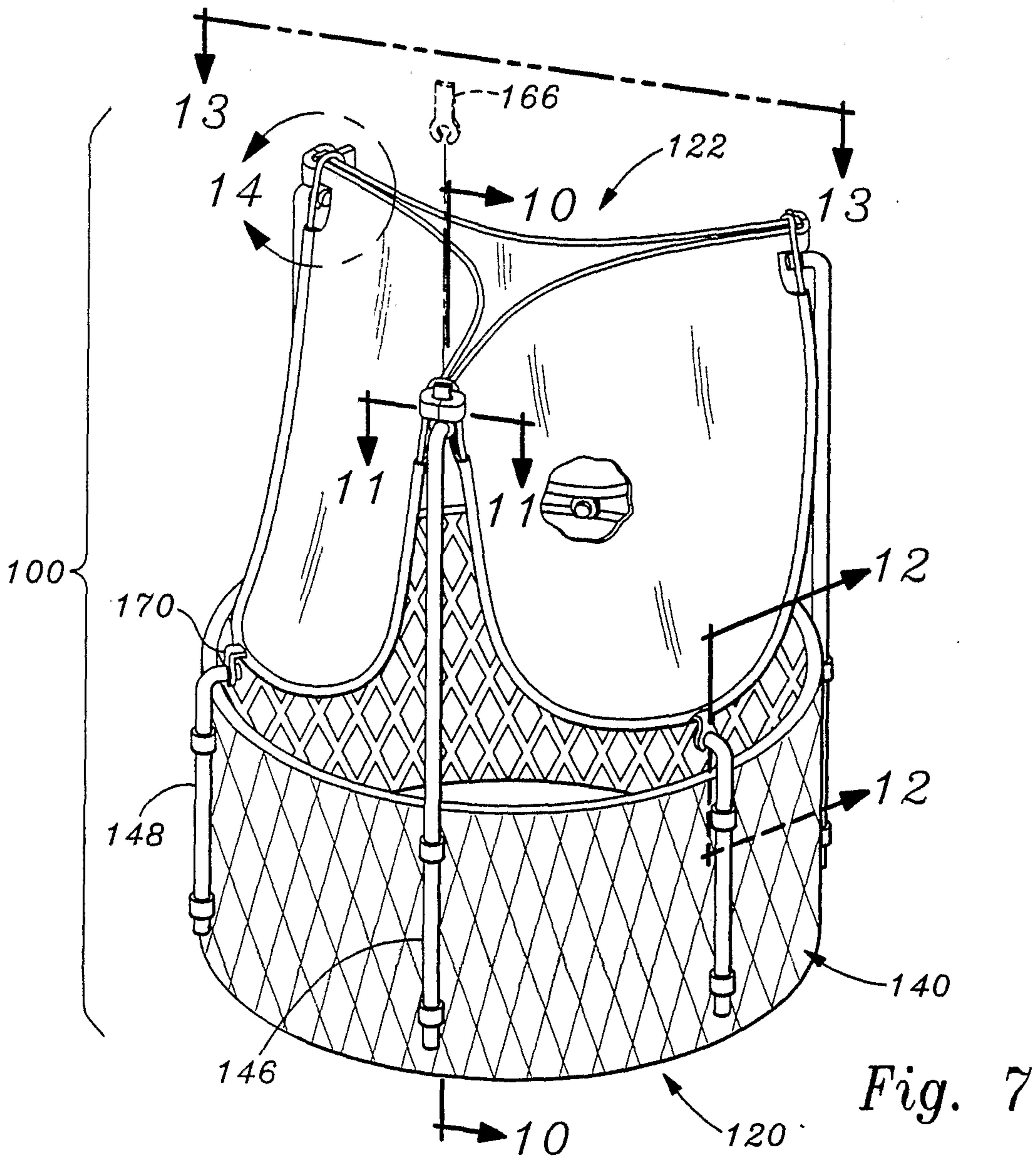
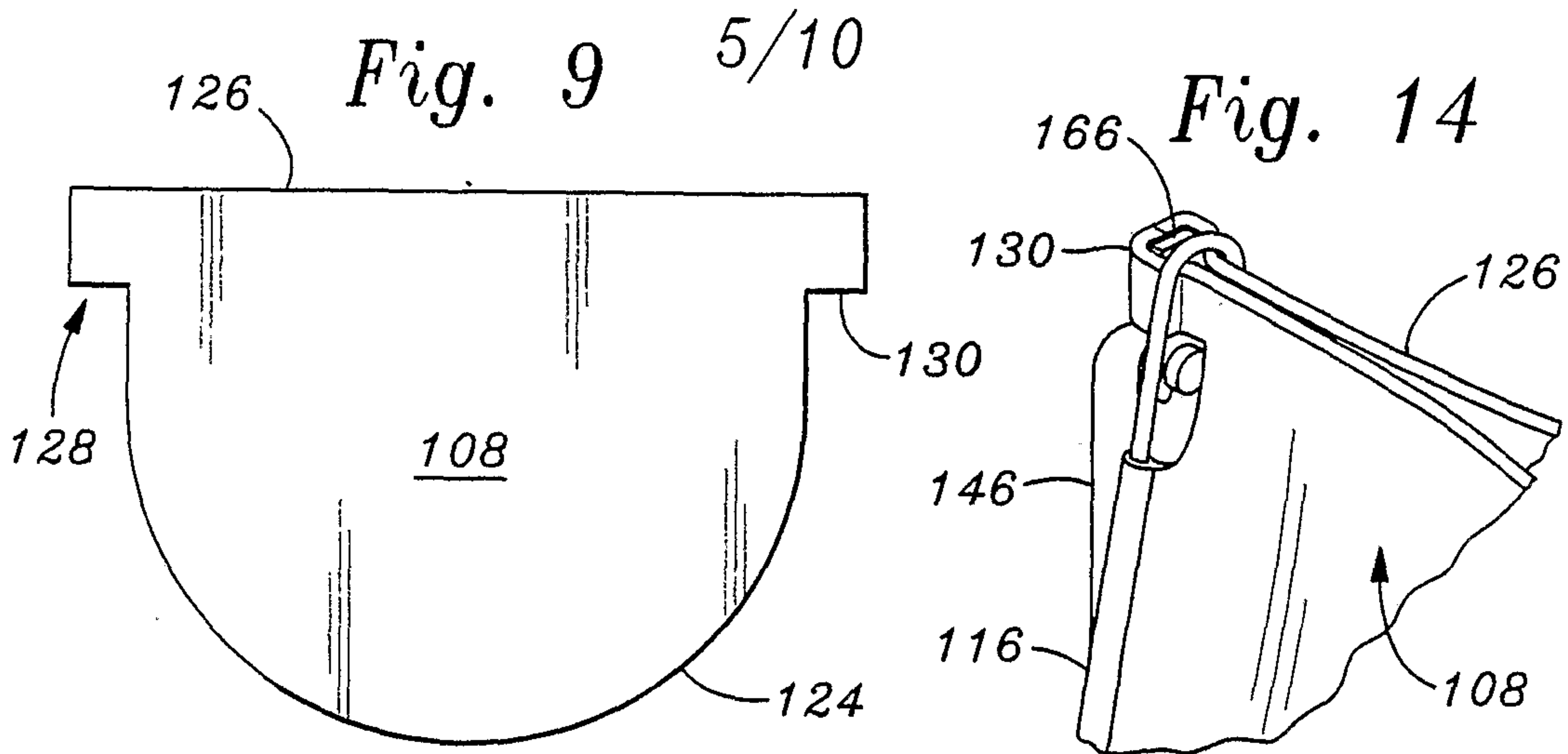

Fig. 6





6/10

Fig. 12

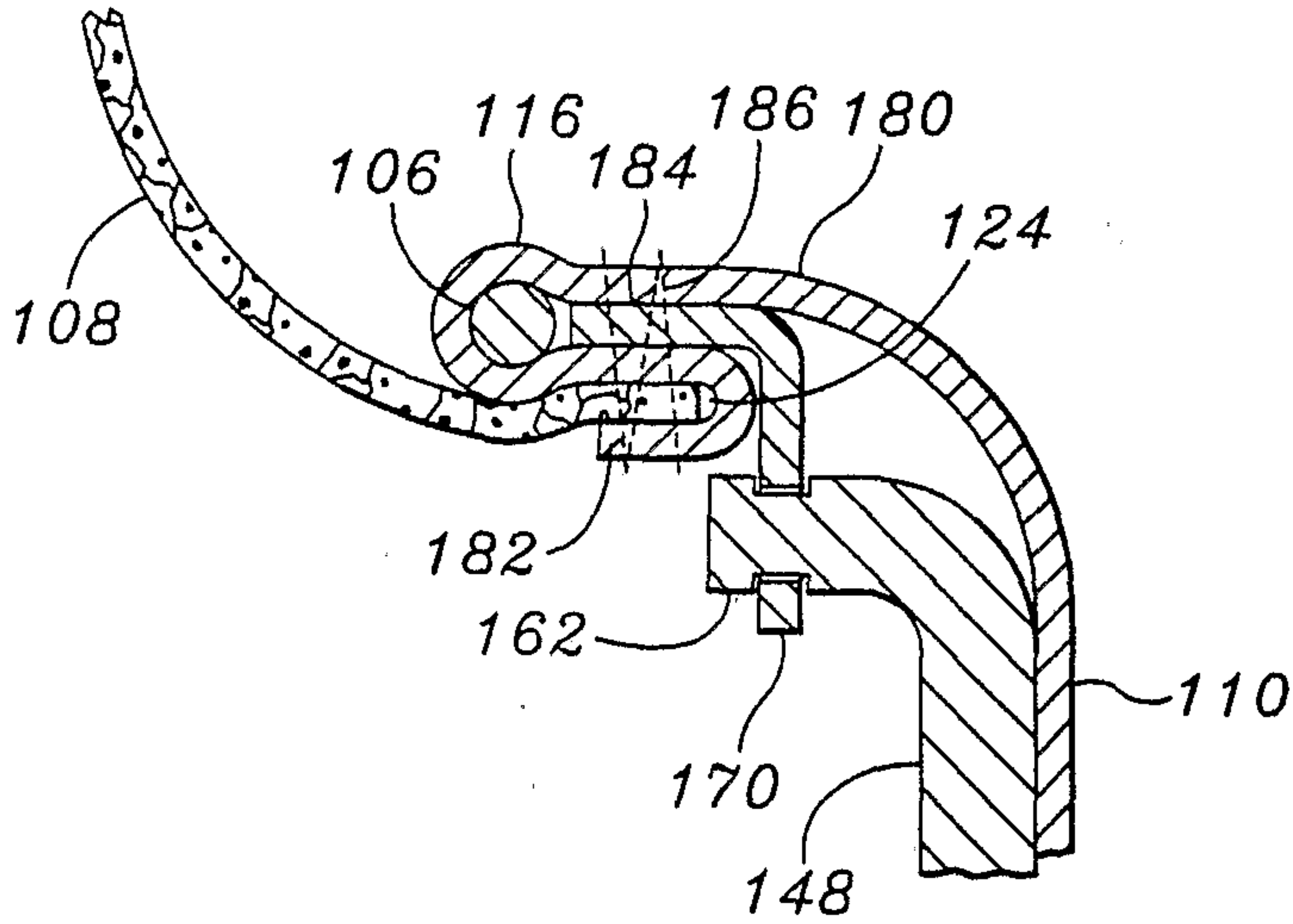

Fig. 8

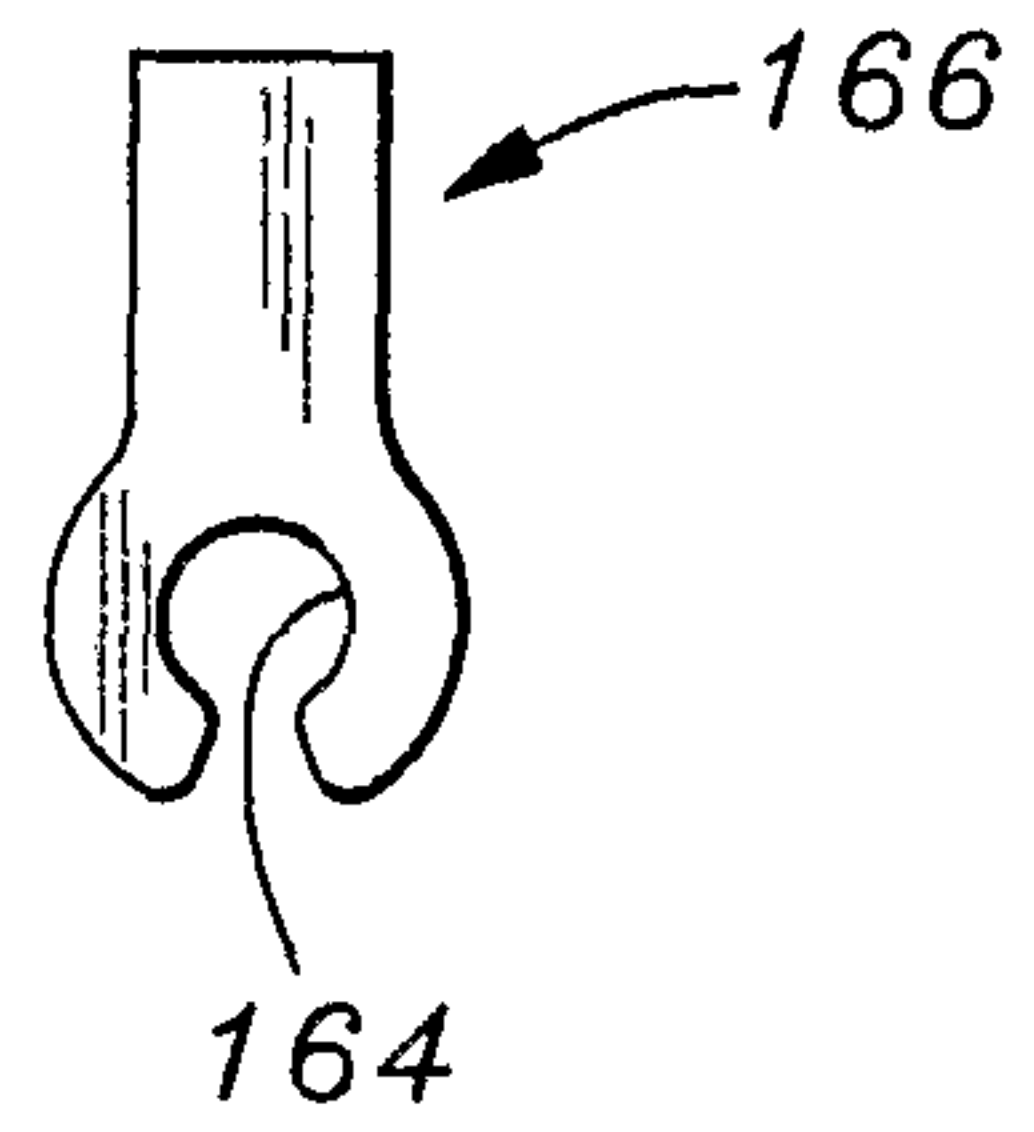

Fig. 10

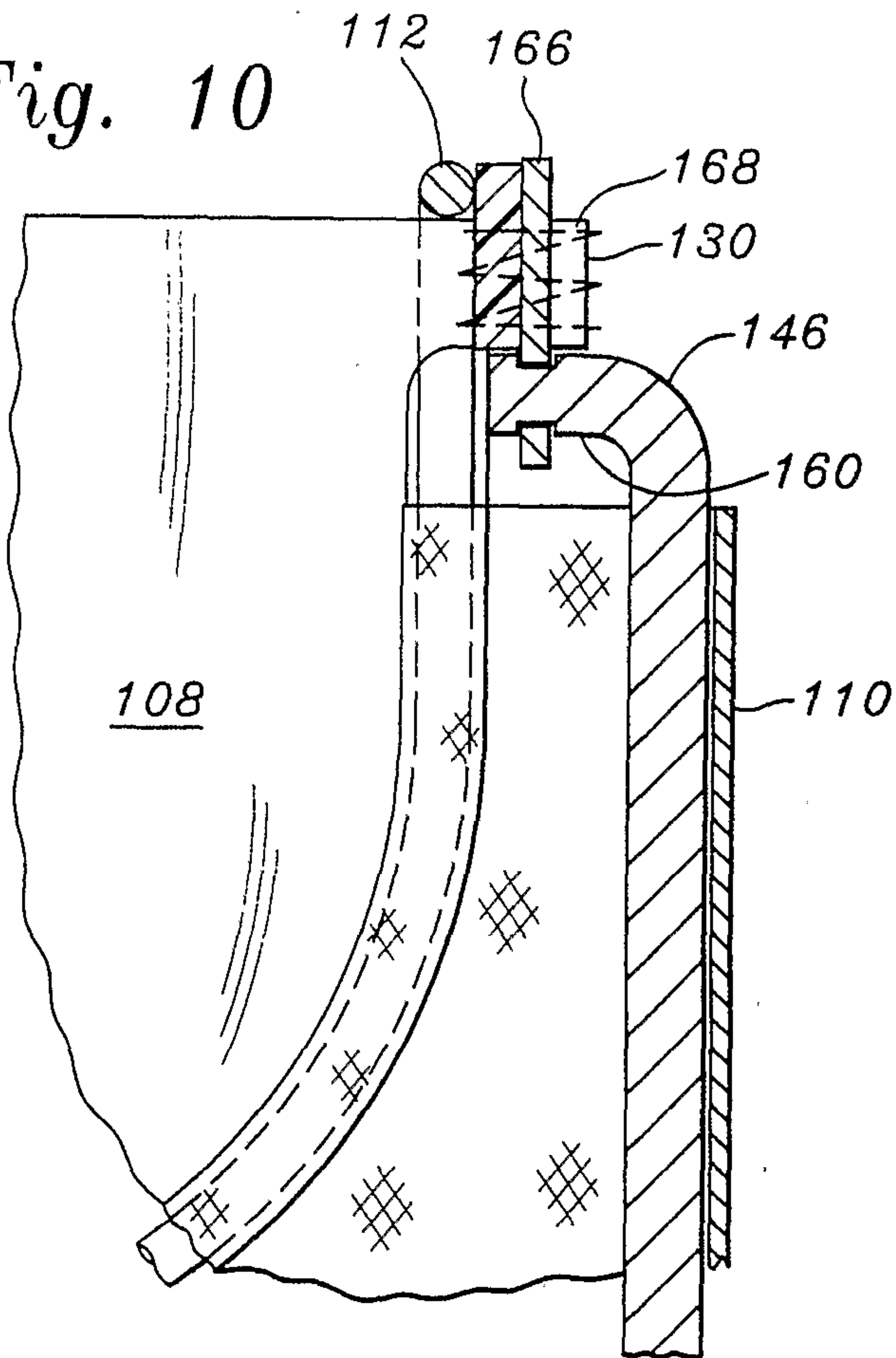
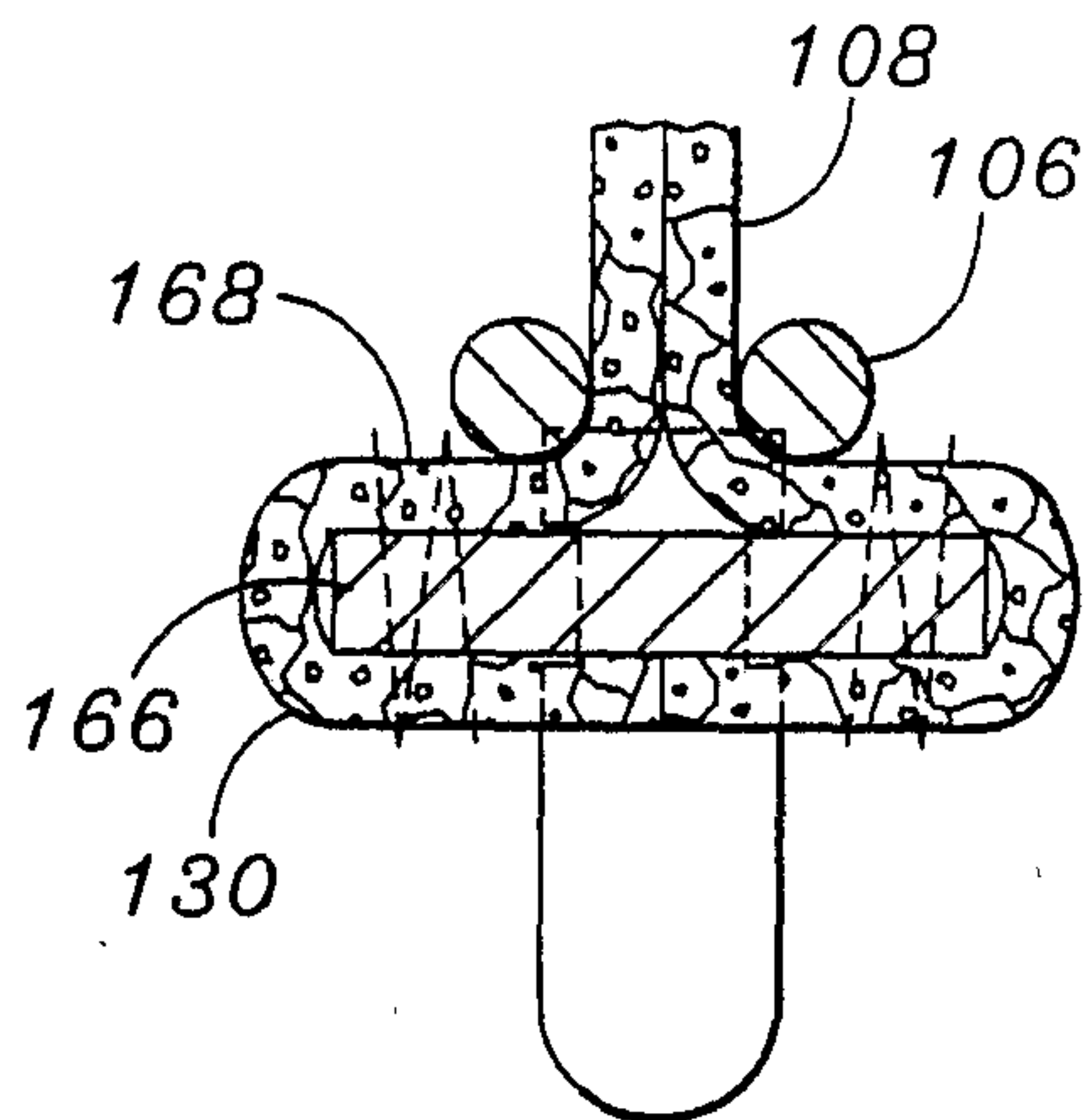

Fig. 11



7/10

Fig. 15

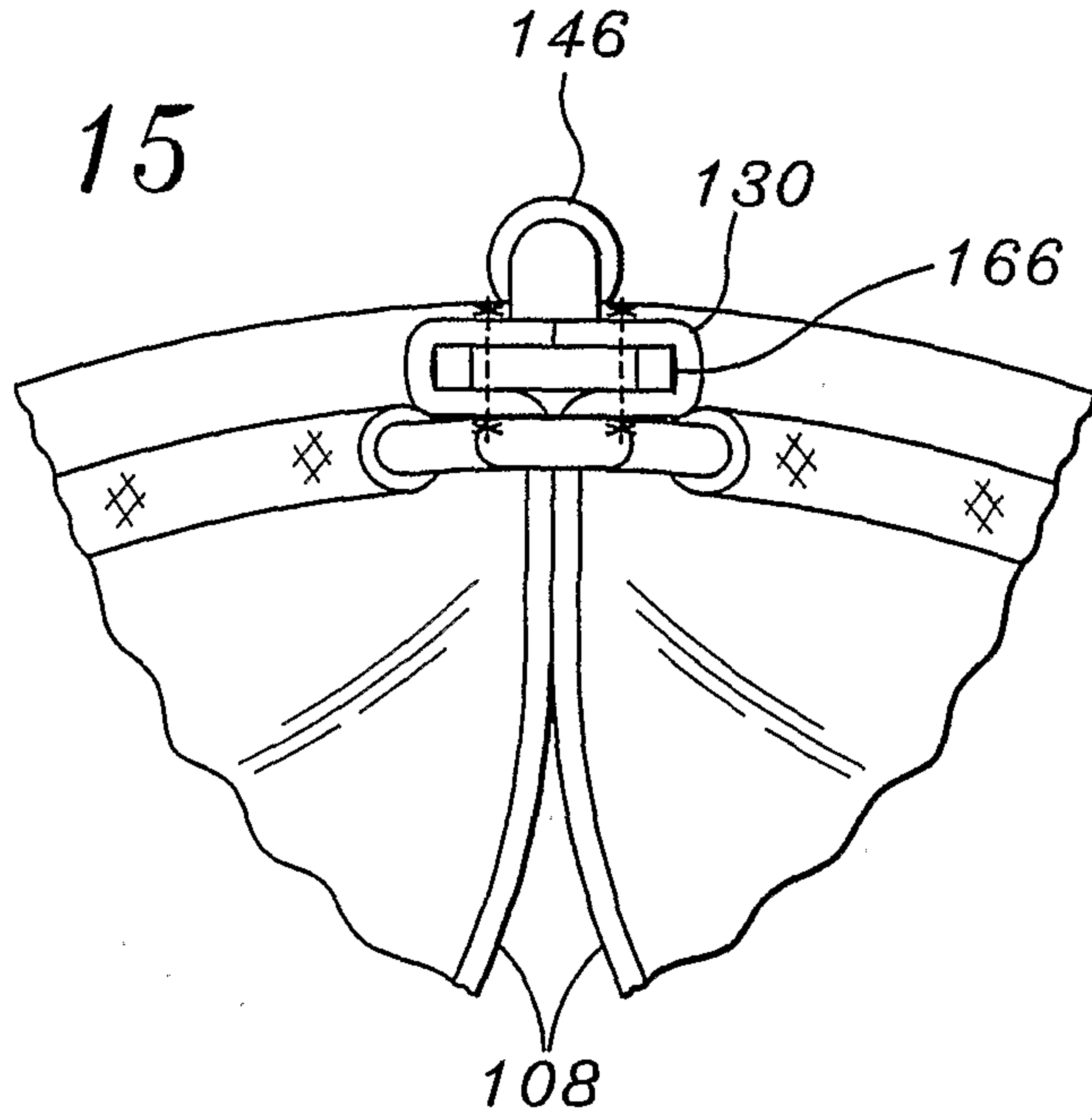
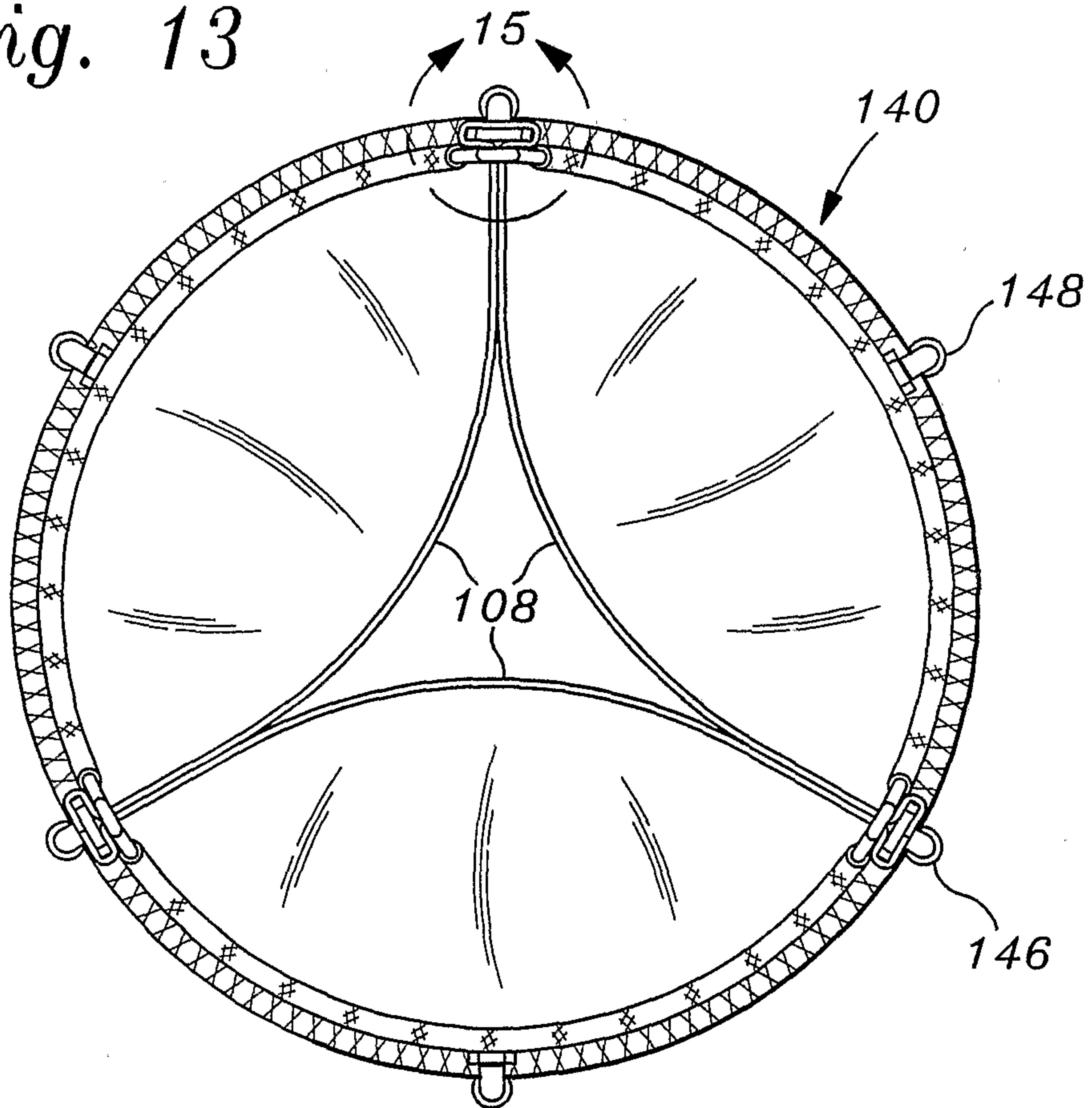

Fig. 13



8/10

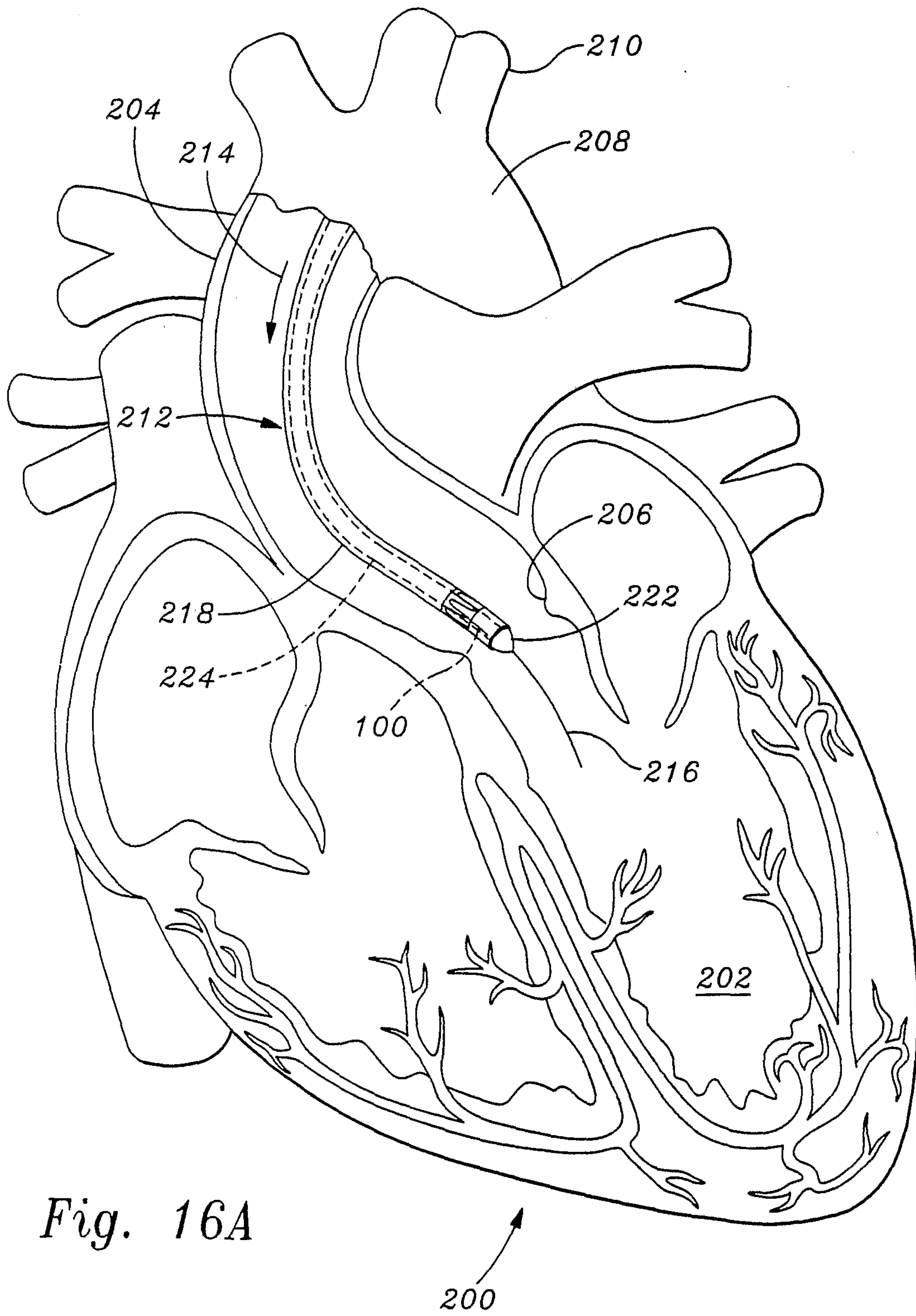

Fig. 16A

9/10

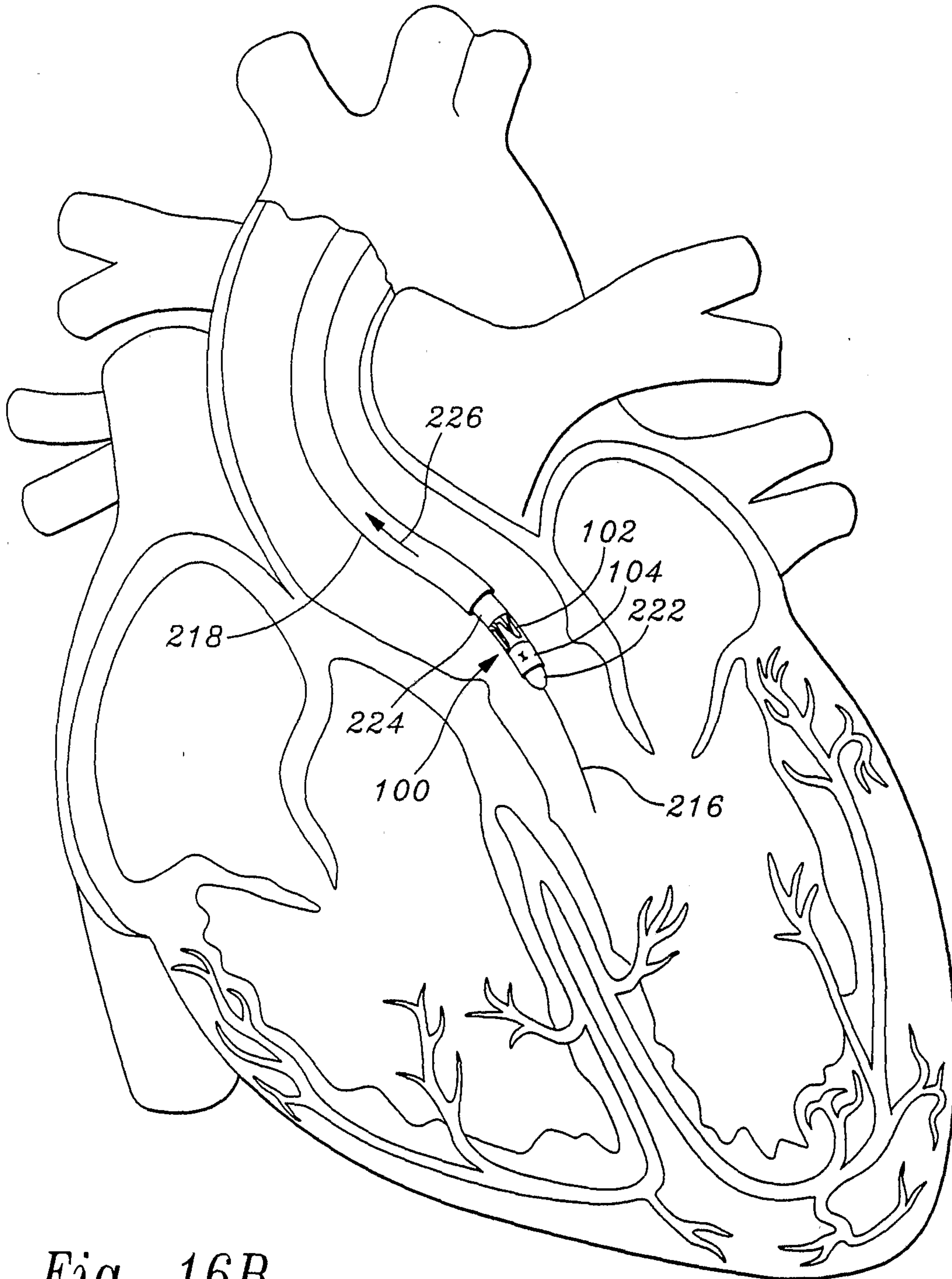

Fig. 16B

10/10

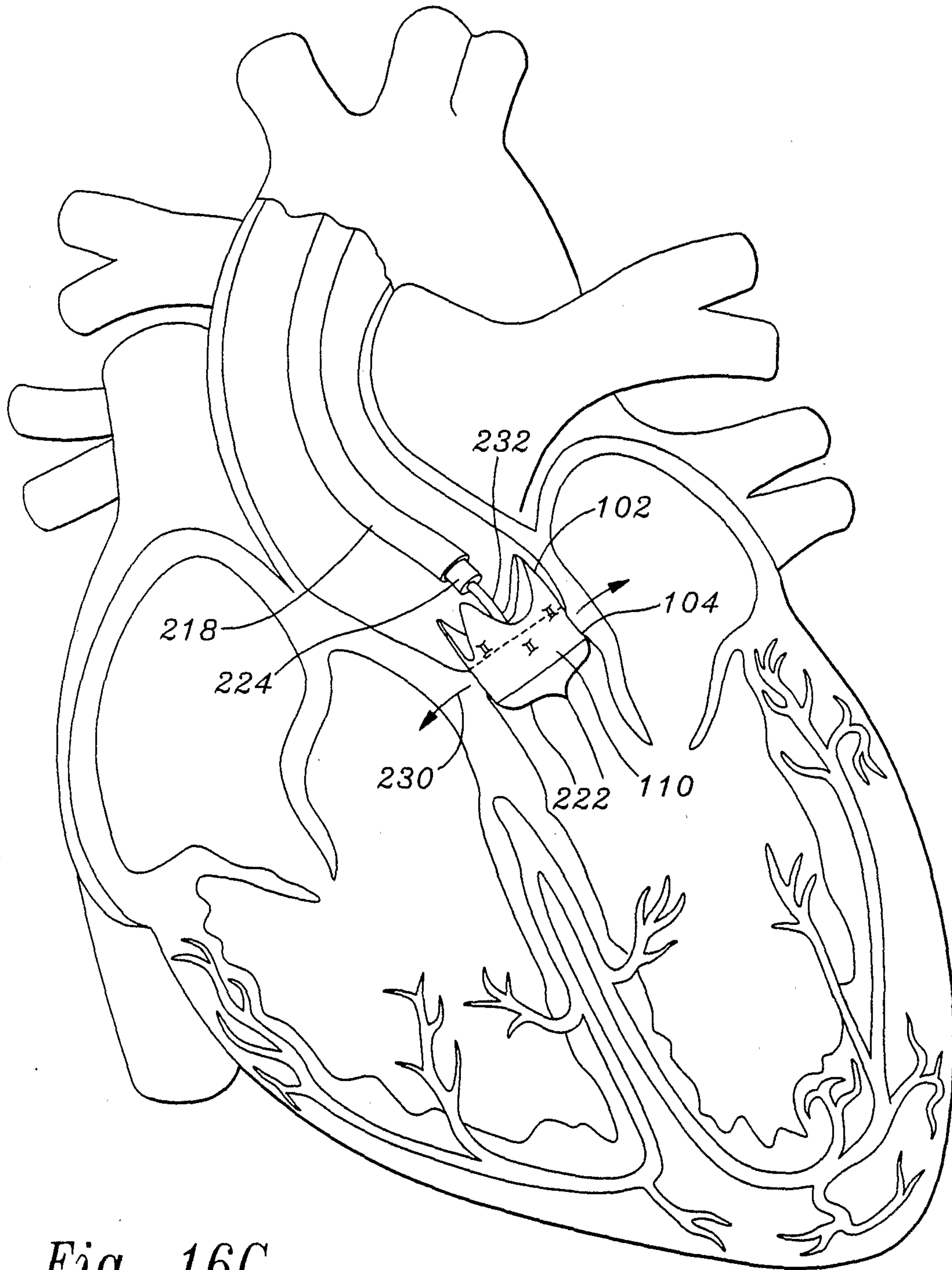

Fig. 16C

